

To our customers,

Old Company Name in Catalogs and Other Documents

On April 1st, 2010, NEC Electronics Corporation merged with Renesas Technology Corporation, and Renesas Electronics Corporation took over all the business of both companies. Therefore, although the old company name remains in this document, it is a valid Renesas Electronics document. We appreciate your understanding.

Renesas Electronics website: <http://www.renesas.com>

April 1st, 2010
Renesas Electronics Corporation

Issued by: Renesas Electronics Corporation (<http://www.renesas.com>)

Send any inquiries to <http://www.renesas.com/inquiry>.

Notice

1. All information included in this document is current as of the date this document is issued. Such information, however, is subject to change without any prior notice. Before purchasing or using any Renesas Electronics products listed herein, please confirm the latest product information with a Renesas Electronics sales office. Also, please pay regular and careful attention to additional and different information to be disclosed by Renesas Electronics such as that disclosed through our website.
2. Renesas Electronics does not assume any liability for infringement of patents, copyrights, or other intellectual property rights of third parties by or arising from the use of Renesas Electronics products or technical information described in this document. No license, express, implied or otherwise, is granted hereby under any patents, copyrights or other intellectual property rights of Renesas Electronics or others.
3. You should not alter, modify, copy, or otherwise misappropriate any Renesas Electronics product, whether in whole or in part.
4. Descriptions of circuits, software and other related information in this document are provided only to illustrate the operation of semiconductor products and application examples. You are fully responsible for the incorporation of these circuits, software, and information in the design of your equipment. Renesas Electronics assumes no responsibility for any losses incurred by you or third parties arising from the use of these circuits, software, or information.
5. When exporting the products or technology described in this document, you should comply with the applicable export control laws and regulations and follow the procedures required by such laws and regulations. You should not use Renesas Electronics products or the technology described in this document for any purpose relating to military applications or use by the military, including but not limited to the development of weapons of mass destruction. Renesas Electronics products and technology may not be used for or incorporated into any products or systems whose manufacture, use, or sale is prohibited under any applicable domestic or foreign laws or regulations.
6. Renesas Electronics has used reasonable care in preparing the information included in this document, but Renesas Electronics does not warrant that such information is error free. Renesas Electronics assumes no liability whatsoever for any damages incurred by you resulting from errors in or omissions from the information included herein.
7. Renesas Electronics products are classified according to the following three quality grades: “Standard”, “High Quality”, and “Specific”. The recommended applications for each Renesas Electronics product depends on the product’s quality grade, as indicated below. You must check the quality grade of each Renesas Electronics product before using it in a particular application. You may not use any Renesas Electronics product for any application categorized as “Specific” without the prior written consent of Renesas Electronics. Further, you may not use any Renesas Electronics product for any application for which it is not intended without the prior written consent of Renesas Electronics. Renesas Electronics shall not be in any way liable for any damages or losses incurred by you or third parties arising from the use of any Renesas Electronics product for an application categorized as “Specific” or for which the product is not intended where you have failed to obtain the prior written consent of Renesas Electronics. The quality grade of each Renesas Electronics product is “Standard” unless otherwise expressly specified in a Renesas Electronics data sheets or data books, etc.
 - “Standard”: Computers; office equipment; communications equipment; test and measurement equipment; audio and visual equipment; home electronic appliances; machine tools; personal electronic equipment; and industrial robots.
 - “High Quality”: Transportation equipment (automobiles, trains, ships, etc.); traffic control systems; anti-disaster systems; anti-crime systems; safety equipment; and medical equipment not specifically designed for life support.
 - “Specific”: Aircraft; aerospace equipment; submersible repeaters; nuclear reactor control systems; medical equipment or systems for life support (e.g. artificial life support devices or systems), surgical implantations, or healthcare intervention (e.g. excision, etc.), and any other applications or purposes that pose a direct threat to human life.
8. You should use the Renesas Electronics products described in this document within the range specified by Renesas Electronics, especially with respect to the maximum rating, operating supply voltage range, movement power voltage range, heat radiation characteristics, installation and other product characteristics. Renesas Electronics shall have no liability for malfunctions or damages arising out of the use of Renesas Electronics products beyond such specified ranges.
9. Although Renesas Electronics endeavors to improve the quality and reliability of its products, semiconductor products have specific characteristics such as the occurrence of failure at a certain rate and malfunctions under certain use conditions. Further, Renesas Electronics products are not subject to radiation resistance design. Please be sure to implement safety measures to guard them against the possibility of physical injury, and injury or damage caused by fire in the event of the failure of a Renesas Electronics product, such as safety design for hardware and software including but not limited to redundancy, fire control and malfunction prevention, appropriate treatment for aging degradation or any other appropriate measures. Because the evaluation of microcomputer software alone is very difficult, please evaluate the safety of the final products or system manufactured by you.
10. Please contact a Renesas Electronics sales office for details as to environmental matters such as the environmental compatibility of each Renesas Electronics product. Please use Renesas Electronics products in compliance with all applicable laws and regulations that regulate the inclusion or use of controlled substances, including without limitation, the EU RoHS Directive. Renesas Electronics assumes no liability for damages or losses occurring as a result of your noncompliance with applicable laws and regulations.
11. This document may not be reproduced or duplicated, in any form, in whole or in part, without prior written consent of Renesas Electronics.
12. Please contact a Renesas Electronics sales office if you have any questions regarding the information contained in this document or Renesas Electronics products, or if you have any other inquiries.

(Note 1) “Renesas Electronics” as used in this document means Renesas Electronics Corporation and also includes its majority-owned subsidiaries.

(Note 2) “Renesas Electronics product(s)” means any product developed or manufactured by or for Renesas Electronics.

16

CE2000

H8S Series Compact Emulator

Microcomputer Development Environment System

User's Manual

- Blank Page -

User's Manual

Published by : Renesas System Solutions Asia Pte. Ltd.

Date : October 3rd, 2003, Version 2.0

Copyright(C) Renesas System Solutions Asia Pte. Ltd. All rights reserved.

Trademarks

a) General

All brand or product names used in this manual are trademarks or registered trademarks of their respective companies or organizations.

b) Specific

Microsoft, MS and MS-DOS are registered trademarks.

Windows and Windows NT are trademarks of Microsoft Corporation.

Pentium is a registered trademark of Intel.

IMPORTANT INFORMATION

- **READ this user's manual before using this emulator product.**
- **KEEP the user's manual handy for future reference.**

Do not attempt to use the product until you fully understand its mechanism.

ALExxxx & CExxxx Emulator:

Throughout this document, the term "ALExxxx emulator" & "CExxxx emulator" shall be defined as the ALExxxx or CExxxx emulator, user system interface cable, PC interface board, and optional SIMM memory module produced only by Renesas System Solutions Asia Pte. Ltd. excludes all subsidiary products.

The user system or a host computer is not included in this definition.

Purpose of the Emulator Product:

This emulator product is a software and hardware development tool for systems employing the H8S series microcomputer. This emulator product must only be used for the above purpose.

Improvement Policy:

Renesas System Solutions Asia Pte. Ltd. (hereafter collectively referred to as Renesas) pursues a policy of continuing improvement in design, performance, and safety of the emulator product. Renesas reserves the right to change, wholly or partially, the specifications, design, user's manual, and other documentation at any time without notice.

Target User of the Product:

This product should only be used by those who have carefully read and thoroughly understood the information as well as restrictions contained in the user's manual. Do not attempt to use the product until you fully understand its mechanism. It is highly recommended that first-time users. Be instructed by users that are well versed in the operation of emulator product.

LIMITED WARRANTY

Renesas warrants its products to be manufactured in accordance with published specifications and free from defects in material and/or workmanship. The foregoing warranty does not cover damage caused by fair wear and tear, abnormal store condition, incorrect use, accidental misuse, abuse, neglect, corruption, misapplication, addition or modification or by the use with other hardware or software, as the case may be, with which the product is incompatible. No warranty of fitness for a particular purpose is offered. The user assumes the entire risk of using the product. Any liability of Renesas is limited exclusively to the replacement of defective materials or workmanship.

DISCLAIMER

RENESAS MAKES NO WARRANTIES, EITHER EXPRESS OR IMPLIED, ORAL OR WRITTEN, EXCEPT AS PROVIDED HEREIN, INCLUDING WITHOUT LIMITATION THEREOF, WARRANTIES AS TO MARKETABILITY, MECHRCHANTABILITY, FITNESS FOR ANY PARTICULAR PURPOSE OR USE, OR AGAINST INFRINGEMENT OF ANY PATENT. IN NO EVENT SHALL RENESAS BE LIABLE FOR ANY DIRECT, INCIDENTAL OR CONSEQUENTIAL DAMAGES OF ANY NATURE, OR LOSSES OR EXPENSES RESULTING FROM ANY DEFECTIVE EMULATOR PRODUCT, THE USE OF ANY EMULATOR PRODUCT OR ITS DOCUMENTATION, EVEN IF ADVISED OF THE POSSIBILITY OF SUCH DAMAGES. EXCEPT AS EXPRESSLY STATED OTHERWISE IN THIS WARRANTY, THIS EMULATOR PRODUCT IS SOLD "AS IS". AND YOU MUST ASSUME ALL RISK FOR THE USE AND RESULTS OBTAINED FROM THE EMULATOR PRODUCT.

State Law:

Some states do not allow the exclusion or limitation of implied warranty or liability for incidental or consequential damages, so the above limitation or exclusion may not apply to you. This warranty gives you specific legal rights, and you may have other rights which may vary from state to state.

The Warranty is Void in the Following Cases:

Renesas shall have no liability or legal responsibility for any problems caused by misuse, abuse, misapplication, neglect, improper handling, installation, repair or modifications of the emulator product without Renesas's prior written consent or any problems caused by the user system.

Restrictions:

1. Earthing (applies only to manual for Renesas hardware products)
This hardware is designed for use with equipment that is fully earthed.
Ensure that all equipments used are appropriately earthed.
Failure to do so could lead to danger for the operator or damaged to equipments.
2. Electrostatic Discharge Precautions (applies only to manuals for Renesas hardware products)
This hardware contains devices that are sensitive to electrostatic discharge.
Ensure appropriate precautions are observed during handling and accessing connections.
Failure to do so could result in damage to the equipment.

All Right Reserved:

This user's manual and emulator product are copyrighted and all rights are reserved by Renesas. No part of this user's manual, all or part, any be reproduced or duplicated in any form, in hardcopy or machine-readable form, by any means available without Renesas's prior written consent.

Other Important Things to Keep in Mind:

1. Circuitry and other examples described herein are meant merely to indicate the characteristics and performance of Renesas Technology's semiconductor products. Renesas assumes no responsibility for any intellectual property claims or other problems that may result from applications based on the examples described herein.
2. No license is granted by implication or otherwise under any patents or other rights of any third party or Renesas.
3. MEDICAL APPLICATIONS: Renesas Technology's products are not authorized for use in MEDICAL APPLICATIONS without the written consent of the appropriate officer of Renesas Technology (Asia Sales company). Such use includes, but is not limited to, use in life support systems. Buyers of Renesas Technology's products are requested to notify the relevant Renesas Technology (Asia Sales offices) when planning to use the products in MEDICAL APPLICATIONS.

Figures:

Some figures in this user's manual may show items different from your actual system.

Limited Anticipation of Danger:

Renesas cannot anticipate every possible circumstance that might involve a potential hazard. The warnings in this user's manual and on the emulator product are therefore not all inclusive. Therefore, you must use the emulator product safely at your own risk.

PREFACE

About this manual

This manual explains how to setup the Compact Emulator for usage of the H8S series microcomputers. Operation using High-performance Embedded Workshop(HEW) as pure debugger is also detailed in the context.

- Section 1** Introduction
Gives an introduction to the system package and specification. It also highlights the precautionary measures when using the emulator.
- Section 2** Installation
Explains how to install and configure the PC in order to operate the emulator.
- Section 3** Emulation Functions
Usage Note 1 - Describes the various functions used in the CE2000-H8S/2238 emulator.
- Section 4** H8S Function Support
Usage Note 2 - Covers the emulation of the peripherals and features for the H8S microcomputer in the CE2000-H8S/2238 emulator.
- Section 5** Differences between the H8S Microcomputer and the Emulator
Usage Note 3 - Highlights the differences between the usage of the emulator and the actual MCU.
- Section 6** User System Interface
Usage Note 4 - Details information about the user interface circuitry and memory access timing
- Section 7** Diagnostic
Performs a self-diagnostic test with the standalone emulator.
- Section 8** Trouble-Shooting
Advises on some basic fault locating methods and commonly made mistakes.

Assumptions

This manual assumes that the user has a working knowledge of

- High-performance Embedded Workshop (Compiler, Assembler and Linker)
- H8S Architecture
- General Hardware Interface Circuitry
- General Personal Computer Operation
- MS-Window programs

Related Manuals:

- H8S, H8/300 Series C/C++ Compiler Package Manual (Installed with HEW)
- High-performance Embedded Workshop 2 help
- H8S Series Hardware Manual
- SODIMM User's Manual
- CE2000 User Cable User's Manual

Table of Contents

SECTION 1.	INTRODUCTION.....	1
1.1	OVERVIEW	1
1.2	PACKAGE CONTENTS	2
1.2.1	<i>Hardware Components</i>	2
1.2.2	<i>Software Components</i>	2
1.2.3	<i>Optional Components</i>	2
1.3	SYSTEM REQUIREMENT.....	3
1.4	SUPPORTED MCU SERIES BY CE2000-H8S/2238 EMULATOR	3
1.5	SUMMARY OF CE2000-H8S/2238 EMULATOR FUNCTIONS	4
1.6	PRECAUTIONARY MEASURES	7
SECTION 2.	SETUP.....	9
2.1	EXPRESS SETUP STEPS	9
2.2	INSTALLING HEW SOFTWARE.....	10
2.3	INSTALLING THE USB DRIVER.....	12
2.4	CE PROGRAMMER (OS AND LOGIC UPGRADE).....	15
2.5	INSTALLATION DETAILS.....	17
2.6	POWER UP THE EMULATOR.....	18
2.7	CHECKING THE SYSTEM (STANDALONE MODE).....	18
2.7.1	<i>LED indication</i>	18
2.8	ACTIVATION OF THE EMULATION SYSTEM.....	19
2.8.1	<i>Creating new workspace</i>	19
2.9	CONFIGURE THE PLATFORM.....	20
2.9.1	<i>Device and Package Selection</i>	21
2.9.2	<i>Operating Mode Selection</i>	21
2.9.3	<i>Clock Selection</i>	21
2.9.4	<i>User Signal Masking Control (RESET, NMI & STBY)</i>	21
2.9.5	<i>Downloading of Emulation Function (Programmable Function Generator)</i>	21
2.10	MEMORY MAPPING	22
2.11	CONNECTION TO TARGET SYSTEM.....	23
2.11.1	<i>Target Power Supply</i>	23
2.11.2	<i>Types of User Interface Cable</i>	23
2.12	OPTIONAL SODIMM MEMORY SELECTION	25
SECTION 3.	EMULATION FUNCTIONS.....	28
3.1	OVERVIEW	28
3.1.1	<i>Emulation</i>	28
3.1.2	<i>High-performance Embedded Workshop(HEW)</i>	28
3.2	PROGRAMMABLE FUNCTION GENERATOR (PFG).....	30
3.3	PIN VIEW	30
3.4	GO (RESET GO, GO AT PC, GOTO CURSOR)	30
3.5	RESET CPU	30
3.6	SINGLE-STEP.....	30
3.7	BREAK FUNCTIONS	31
3.7.1	<i>Event Breakpoint</i>	32
3.7.2	<i>PFG Function – PFG Breakpoint</i>	32

3.8	RUN TIME MEASUREMENT.....	32
3.9	PFG FUNCTION - TRACE.....	32
3.10	MEMORY FUNCTIONS.....	33
3.11	PARALLEL-ON-THE-FLY (POTF)	33
3.12	MEMORY MAPPING.....	33
3.13	CPU AND I/O REGISTERS ACCESS	34
3.14	SESSION	35
3.15	C-SOURCE LEVEL DEBUGGING.....	35
SECTION 4.	H8S FUNCTION SUPPORTED.....	36
4.1	MCU OPERATING MODE SETTING.....	36
4.2	MEMORY AREA.....	36
4.2.1	INTERNAL ROM AREA	36
4.2.2	INTERNAL RAM AREA	36
4.2.3	INTERNAL I/O AREA	36
4.2.4	EXTERNAL AREA	37
4.3	LOW POWER MODE.....	37
4.3.1	<i>Hardware Standby Mode</i>	<i>37</i>
4.3.2	<i>Sleep and Software Standby Modes</i>	<i>37</i>
4.3.3	<i>Medium Speed and Module Stop Modes</i>	<i>37</i>
4.4	INTERRUPTS	38
4.5	CONTROL INPUT SIGNALS (RES, NMI, STBY)	38
4.6	WATCH DOG TIMER (WDT)	38
4.7	16-BIT TIMER PULSE UNIT (TPU) AND 8-BIT TIMER.....	38
4.8	SERIAL COMMUNICATIONS INTERFACE (SCI)	38
4.9	PROGRAMMABLE PULSE GENERATOR (PPG)	38
4.10	DMA CONTROLLER (DMAC)	38
4.11	DATA TRANSFER CONTROLLER (DTC).....	39
4.12	BUS STATE CONTROLLER	39
4.13	I/O PORTS	39
4.14	A/D CONVERTER	39
SECTION 5.	DIFFERENCES BETWEEN H8S MICROCOMPUTER AND EMULATOR.....	40
5.1	POWER UP AND RESET	40
5.2	USER INTERFACE	41
SECTION 6.	USER SYSTEM INTERFACE.....	42
SECTION 7.	TUTORIAL.....	46
7.1	INTRODUCTION	46
7.2	OVERVIEW.....	46
7.3	HOW THE TUTORIAL PROGRAM WORKS	47
7.4	RUNNING HEW.....	49
7.4.1	<i>Opening Tutorial workspace.....</i>	<i>49</i>
7.5	SETTING UP THE HEW(PURE DEBUGGER) FOR CE2000-H8S/2238	50
7.5.1	<i>Configuring the Platform</i>	<i>50</i>
7.5.2	<i>Mapping the Memory.....</i>	<i>51</i>
7.6	DOWNLOADING THE TUTORIAL PROGRAM.....	53
7.6.1	<i>Loading the Download Module.....</i>	<i>53</i>
7.6.2	<i>Displaying the Program Listing.....</i>	<i>53</i>

7.7	USING BREAKPOINTS	54
7.7.1	<i>Setting a Program Count (PC) Breakpoint</i>	54
7.7.2	<i>Executing the Program</i>	55
7.7.3	<i>Reviewing the Breakpoints</i>	56
7.7.4	<i>Examining MCU Registers</i>	57
7.8	EXAMINING MEMORY AND VARIABLES	58
7.8.1	<i>Viewing Memory</i>	58
7.8.2	<i>Watching Variables</i>	59
7.9	STEPPING THROUGH A PROGRAM	61
7.9.1	<i>Stepping</i>	61
7.10	USING THE PFG BREAKPOINT	62
7.10.1	<i>Defining a PFG Breakpoint</i>	62
7.11	WATCHING LOCAL VARIABLES	65
7.12	USING THE TRACE BUFFER	66
7.12.1	<i>Displaying the Trace Buffer</i>	66
7.13	PIN VIEW	67
7.14	SAVE THE SESSION	67
SECTION 8. DIAGNOSTIC		68
8.1	STANDALONE SELF TEST	68
SECTION 9. TROUBLE-SHOOTING		69
APPENDIX A : USER CONNECTOR PIN ASSIGNMENT		A-1
APPENDIX B : USER CONNECTOR SPECIFICATION		B-1
APPENDIX C : USER CONNECTOR PIN LAYOUT		C-1
APPENDIX D : CASING ASSEMBLY		D-1
APPENDIX E : TECHNICAL SPECIFICATION		E-1
APPENDIX F : FREQUENTLY ASKED QUESTIONS		F-1
RENESAS TECHNOLOGY (ASIA SALES OFFICES)		

List of Figures

Figure 1-1	CE2000-H8S/2238 Emulator	1
Figure 1-2	CE2000-H8S/2238 Emulator Package.....	2
Figure 2-1	Basic Setup of CE2000-H8S/2238 Emulator.....	9
Figure 2-2	Compact Emulator	9
Figure 2-3	Installing HEW package with Tool chain	10
Figure 2-4	Installing HEW(Pure Debugger).....	11
Figure 2-5	Found New Device.....	12
Figure 2-6	Locate Driver Files.....	12
Figure 2-7	Selecting the USB Driver Location	13
Figure 2-8	Win2K Driver Location	13
Figure 2-9	Win 9x Driver Location	14
Figure 2-10	Selected Driver File Window.....	14
Figure 2-11	Compact Emulator USB Driver Installed	15
Figure 2-12	CE Programmer Window.....	16
Figure 2-13	CE OS and Logic Programming	16
Figure 2-14	End of Programming.....	17
Figure 2-15	HEW Start up Menu.....	17
Figure 2-16	Power-supply Plug	18
Figure 2-17	Execute HEW from Start Menu	19
Figure 2-18	Creating new workspace	20
Figure 2-19	Configure Platform dialog	20
Figure 2-20	Memory Mapping dialog	22
Figure 2-21	Editing the Memory Mapping.....	23
Figure 2-22	User Interface Cable – Direct Connection	24
Figure 2-23	User Interface Cable – Actual Footprint.....	24
Figure 2-24	Addition of Optional Memory Address Range.....	25
Figure 2-25	Memory Mapping Window.....	26
Figure 3-1	HEW desktop window	29
Figure 3-2	Modification of Mapping Memory	34
Figure 6-1	Basic Bus Cycle Timing in Expanded mode	43
Figure 6-2	Interfacing Circuitry.....	44
Figure 7-1	Execute HEW from Start Menu	49
Figure 7-2	Open Tutorial workspace	49
Figure 7-3	Configure Platform dialog	50
Figure 7-4	Memory Mapping Dialog.....	51
Figure 7-5	Memory page of Status window	51
Figure 7-6	Edit Memory Mapping Dialog.....	52
Figure 7-7	Debug Settings Dialog	53
Figure 7-8	resetprg.c file after RESET CPU	54
Figure 7-9	Setting a Breakpoint.....	54
Figure 7-10	Program Break	55
Figure 7-11	Platform page of Status Window	55
Figure 7-12	Eventpoints Window	56
Figure 7-13	Popup menus in Eventpoints Window.....	56
Figure 7-14	CPU Registers Window.....	57
Figure 7-15	Changing Register Value	57
Figure 7-16	Open Memory Window	58

Figure 7-17	Memory Window	58
Figure 7-18	Instant Watch dialog.....	59
Figure 7-19	Watch Window	59
Figure 7-20	Add Watch Dialog	60
Figure 7-21	Watch Window	60
Figure 7-22	Displaying Individual Elements in an Array	61
Figure 7-23	Step In	61
Figure 7-24	Step Over	62
Figure 7-25	Breakpoint Setting Dialog.....	63
Figure 7-26	PFG Programming	63
Figure 7-27	Eventpoints Window	64
Figure 7-28	PFG Break.....	64
Figure 7-29	Locals Window	65
Figure 7-30	Displaying Individual Elements in an Array	65
Figure 7-31	Trace Window	66
Figure 7-32	Pin View Window	67

List of Tables

Table 1-1	CE2000-H8S/2238 Emulator Functions	4
Table 3-1	Types of Breaks Encountered During Emulation.	31
Table 4-1	MCU Operating Modes.....	36
Table 5-1	Differences between H8S and Emulator.....	40

Section 1. Introduction

1.1 Overview

The *CE2000-H8S/2238 Compact Emulator* is one of the Renesas's Development Tool series. It is produced as a cost-effective, easy-to-use support tools.

The CE2000-H8S/2238 emulator has an easy to setup USB link and a common user-friendly Windows-based interface *High-performance Embedded Workshop*(HEW). Its flexibility is evident in its *Programmable Function Generator* (PFG) which allows user to select and download different emulation features. It has a built-in *Self Test* module that will inform user of its working condition through the LED indicator. Moreover, it has integrated a *PinView* module, that allow user to have an instant graphical view of the microcomputer pins' status.

The CE2000-H8S/2238 emulator can be used as a standalone unit for software development and debugging. It can also be connected to a target system via a user interface cable for troubleshooting user's hardware. It is an indispensable tool that caters to the needs of an embedded designer.



Figure 1-1 CE2000-H8S/2238 Emulator

1.2 Package Contents

The CE2000-H8S/2238 emulator is supplied in a package containing the following components:

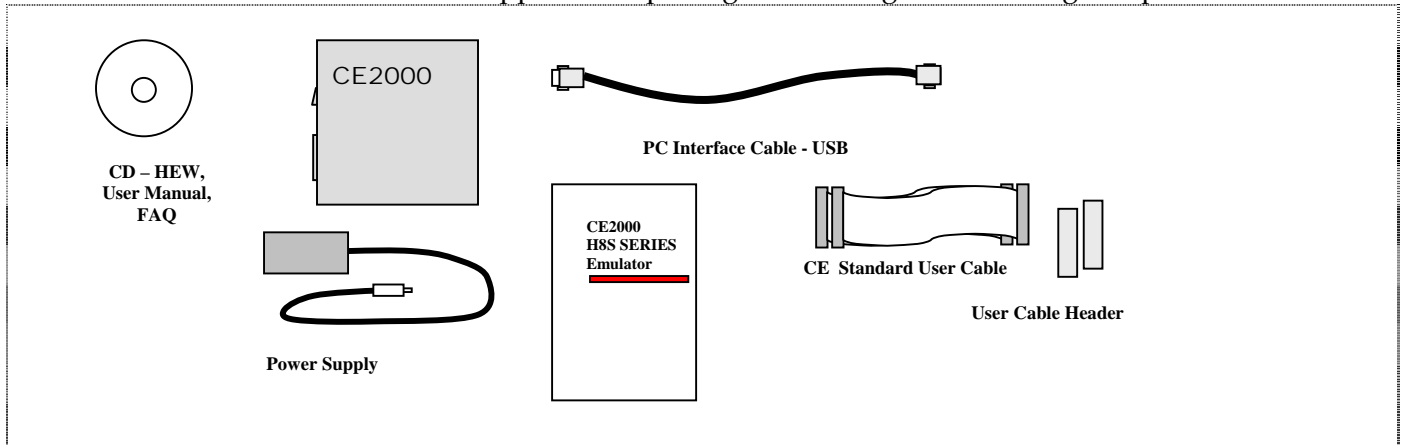

Figure 1-2 CE2000-H8S/2238 Emulator Package

1.2.1 Hardware Components

The hardware components included in the package are listed below.

- 1 x CE2000-H8S/2238 emulator
- 1 x PC interface cable – USB cable
- 1 x 300mm KEL user interface cable to connect to target system (Part No.: 8822E-080-171-30-AC)
- 1 x 400mm KEL user interface cable to connect to target system (Part No.: 8822E-080-171-40-AC)
- 2 x KEL connector plugs for the target system (Part No.: 8830E-080-170S)
- 1 x 5V-2.6A power supply adaptor (Ratings: 110-240V/50-60Hz)

1.2.2 Software Components

The software components included in the package are listed below.

- 1 x CD containing HEW(Pure Debugger) Installation, user's manual and FAQ. The HEW(Pure Debugger) does not include Renesas's Toolchain of Compiler.

Before proceeding, user has to check that all the items listed in the packing list. Please contact the relevant Renesas Sales Office if any item is missing.

1.2.3 Optional Components

The following items can be purchased to further enhance the emulation capability:

- Actual footprint user cable
- 2Mbytes of SODIMM optional memory

1.3 System Requirement

The following items are not supplied but they are required to be used with the CE2000-H8S/2238 emulator.

- A minimum Pentium™ or equivalent based processor personal computer with USB version 1.1.
- Microsoft Windows 98(2nd Edition)/Me/2000/XP
- Memory capacity: at least 128 Mbytes; 256 Mbytes or more recommended.
- Hard disk drive: 100 MB or more (capacity necessary for full installation)

1.4 Supported MCU Series by CE2000-H8S/2238 Emulator

- H8S/2214 series - H8S/2214
- H8S/2215 series - H8S/2215
- H8S/2238 series - H8S/2236(R)(W), 2238(R)(W)
- H8S/2237 series - H8S/2233, 2235, 2237
- H8S/2227 series - H8S/2223, 2224, 2225, 2227
- H8S/2239 series - H8S/2239

1.5 Summary of CE2000-H8S/2238 Emulator Functions

Table 1-1 CE2000-H8S/2238 Emulator Functions

Items	Specifications
Supported Microcomputers	<ul style="list-style-type: none"> • H8S/2214 series - H8S/2214 • H8S/2215 series - H8S/2215 • H8S/2238 series - H8S/2236(R)(W), 2238(R)(W) • H8S/2237 series - H8S/2233, 2235, 2237 • H8S/2227 series - H8S/2223, 2224, 2225, 2227 • H8S/2239 series - H8S/2239
Operating Frequency	<ul style="list-style-type: none"> • 2 MHz (Min) • 16 MHz (Max)
Operating Modes	<ul style="list-style-type: none"> • Mode 5, 6, 7 and 8. • Target
Supported Operating Voltage Range	<ul style="list-style-type: none"> • 2.5 Volts - 5 Volts.
Host Machine	<ul style="list-style-type: none"> • Minimum Pentium™ or equivalent processor PC. • Microsoft Windows 2000/Xp/98(2nd Edition)/Me.
Host Interface	<ul style="list-style-type: none"> • USB Ver 1.1 (12Mbps).
Supported File Formats	<ul style="list-style-type: none"> • Motorola S-type. • ELF/Dwarf. • ELF/Dwarf2.
Interface Software	<ul style="list-style-type: none"> • HEW(Pure Debugger) : 32-bit Windows-based interface providing on-line help.
Emulation Functions	<ul style="list-style-type: none"> • Perform real-time emulation of a target program at 2-16MHz. • C-source level debugging (e.g. C-level step execution, instant watch, view labels...). • Display MCU operating status (e.g. Run, Sleep and Standby) during User run mode. • Display accessed address during execution. • Modify and display MCU registers. • Assemble instruction mnemonics. • Dis-assemble memory contents. • Radix (Bin, Octal, Dec, Hex, ASCII) input. • Loading and saving of session. • Reset MCU. • Go at current PC/ Reset Go/ Go to Cursor

Items	Specifications
Emulation Memory	<ul style="list-style-type: none"> • 512Kbytes internal ROM (max) • 128Kbytes internal RAM (max) • Provision of 4 banks of selectable optional memory block – 2Mbytes SODIMM. (Not in Package)
Memory Functions	<ul style="list-style-type: none"> • Copy, Search, Fill, Load and Save memory functions. • Memory can be edited and viewed in ASCII/ Byte/ Word/ Long/ Single Float/ Double Float format
Parallel On the Fly	<ul style="list-style-type: none"> • Memory viewing and modification during user program execution.
Single Step Functions	<ul style="list-style-type: none"> • Step In. • Step Out. • Step Over.
Breaks	<ul style="list-style-type: none"> • PC breakpoints (max. 256). • Reserved Access Break. • Write-Protected Break. • User break by <i>ESC</i> key. • Two Events breaks (address/address mask /access)**. <p>** under development</p>
Programmable Function Generator	<ul style="list-style-type: none"> • User configurable emulator functions • Current function includes: 256 cycles of Trace Buffer & 2 channels of Address/Data/Mask Breakpoints.
- Trace	<ul style="list-style-type: none"> • Trace memory size: 64-bit x 256 bus cycle • Signals displayed of each bus cycle: <ul style="list-style-type: none"> • 24-bit address bus. • 16-bit data bus. • Displays mnemonics of instructions executed during emulation. • Save Trace data into ASCII format
- Event Breaks	<ul style="list-style-type: none"> • Two event breaks are provided to trigger on the following conditions; <ul style="list-style-type: none"> • Address range • Data with Masking • Event counter
PinView	<ul style="list-style-type: none"> • Provides instant graphical package view of all the pins of selected microcomputer. • Provides an alternative view in text form.

Items	Specifications
Clock selection	<ul style="list-style-type: none"> • Software selection of 2 types of clocks: • User system clock (via user cable) • Emulator internal clock 2–16 MHz at 100KHz resolution
Execution time measurement	<ul style="list-style-type: none"> • Measure the start (run) till end (break) of an execution. • Resolution: 50ns • No upper limit
User Cable interface	<ul style="list-style-type: none"> • Two fine-pitch user cable assemblies (KEL-8822E-080-171-040-AC) are used to interface to two 1.27mm pitch plug (KEL-8830E-080-170S) on both sides of the emulator and user target. (Provided in package) • Selected actual footprint user cables for each microcomputer series are also available. (Not in package)
Voltage Follower	<ul style="list-style-type: none"> • Automatic tracking of the target system supply voltage to ensure that the emulator draws no power.
Power Supply	<ul style="list-style-type: none"> • Power Adaptor Input: 100-240 Vac, 50-60 Hz • Emulator Voltage : 5V Regulated • Current consumption : 2.6A (max)
Environmental	<ul style="list-style-type: none"> • Operating Temperature : 10°C to 35°C • Humidity : 30% to 85% RH • No condensation • No corrosive gas
Field Upgrade	<ul style="list-style-type: none"> • Re-programming of emulator logic and flash OS via USB interface.

1.6 Precautionary Measures

The emulator must be handled with care. Otherwise, it may not work as intended.

Before Power On

- Check all components by referring to the packing list
- Never place heavy objects on the casing

Observe the following conditions in which the emulator is to be used:

- Keep out of direct sunlight or heat
- Use in an environment with constant room temperature and humidity
- Protect the emulator from dust
- Avoid subjecting the emulator to excessive vibration
- Protect the emulator from excessive impact and stresses
- Check the emulators' specifications such as power output, voltage, and frequency before connecting the power supply,
- When moving the emulator, take care to package with good protective box or otherwise damage it. Pay special attention to exposed parts such as power switch and I/O connectors
- Never allow exposed power supply to come into contact with the emulator casing which is grounded.

- Blank Page -

Section 2. Setup

2.1 Express Setup Steps

- Unpack and verify parts against the packing list.
- Power up PC.
- Install HEW by running setup file.
- Power up the CE2000-H8S/2238 emulator.
- Connect USB cable from PC to the emulator within 10 seconds. Otherwise, the CE2000-H8S/2238 emulator will go into Self Test mode.
- Run HEW.

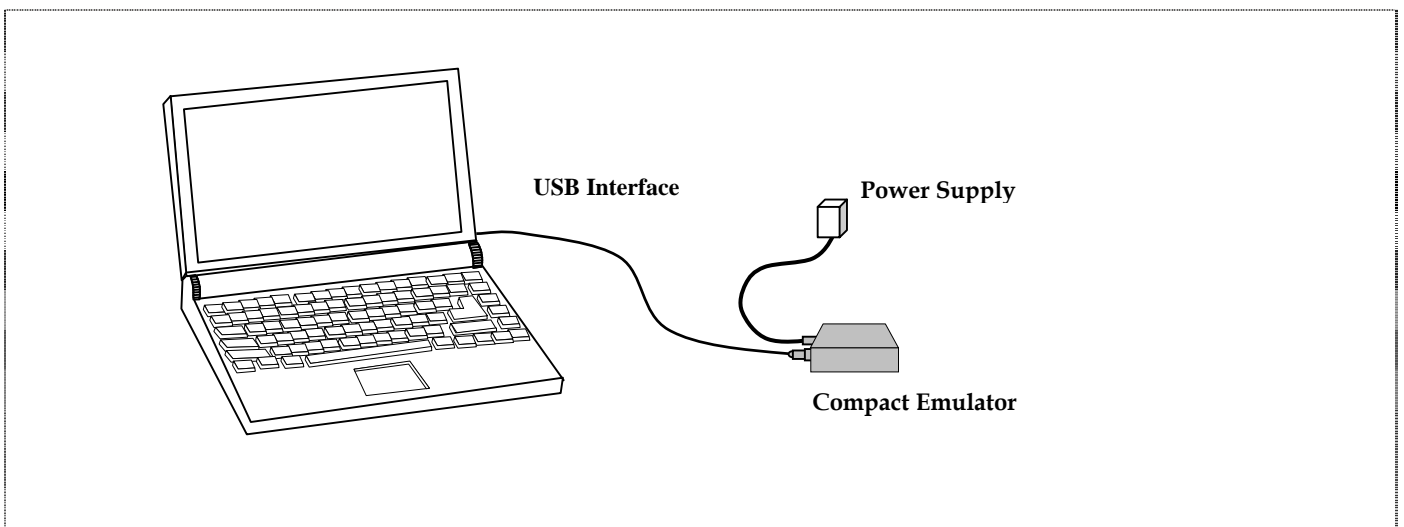

Figure 2-1 Basic Setup of CE2000-H8S/2238 Emulator

The following topics detail the essential steps before proper emulation can be started.

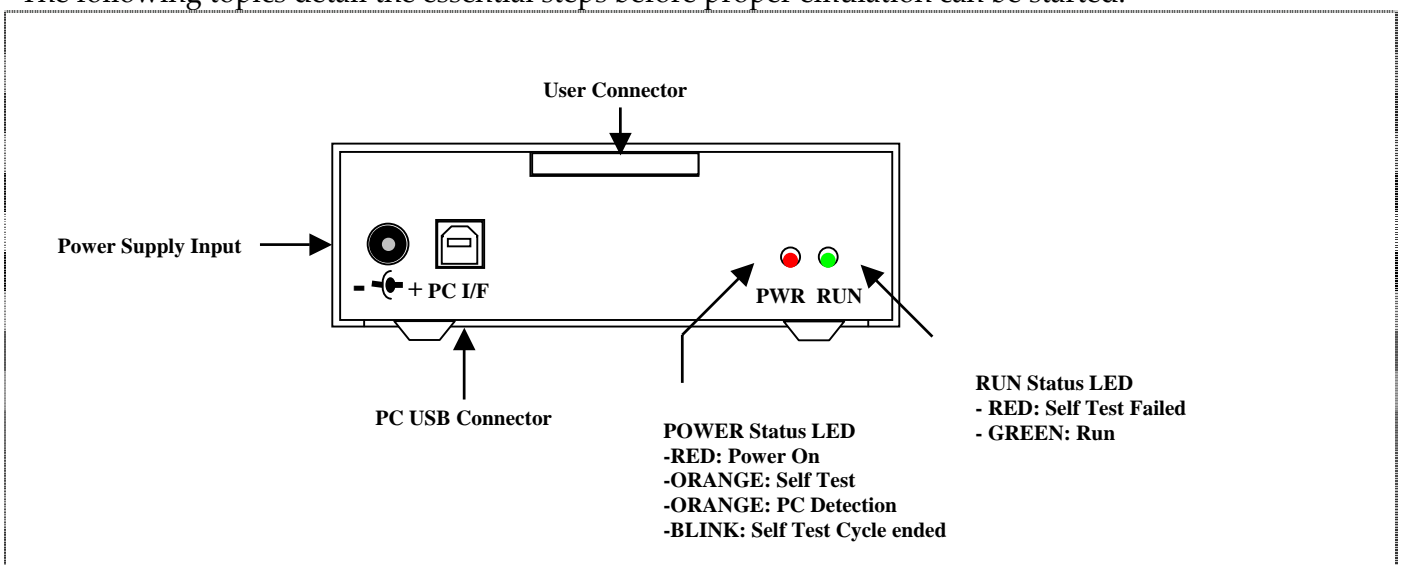

Figure 2-2 Compact Emulator

2.2 Installing HEW software

HEW(Pure Debugger) for CE2000-H8S/2238 can be used alone as pure debugger which users can only do debugging on the download module.

If a user has HEW compiler package with Hitachi's Toolchain, he can use HEW(Pure Debugger) for CE2000-H8S/2238 with integration with the Toolchain. This allows users to do debugging and compiling by using only 1 application.

To install HEW(Pure Debugger) for CE2000-H8S/2238 only, the installation is simple by just running the CE2000.exe.

In order to use **HEW(Pure Debugger) for CE2000-H8S/2238** and **H8S,H8/300 Series C/C++ Compiler**, a user need to install the hew package with tool chain first and then install **HEW(Pure Debugger) for CE2000-H8S/2238** at the same location/directory.

Step:

1. Install HEW package with tool chain.

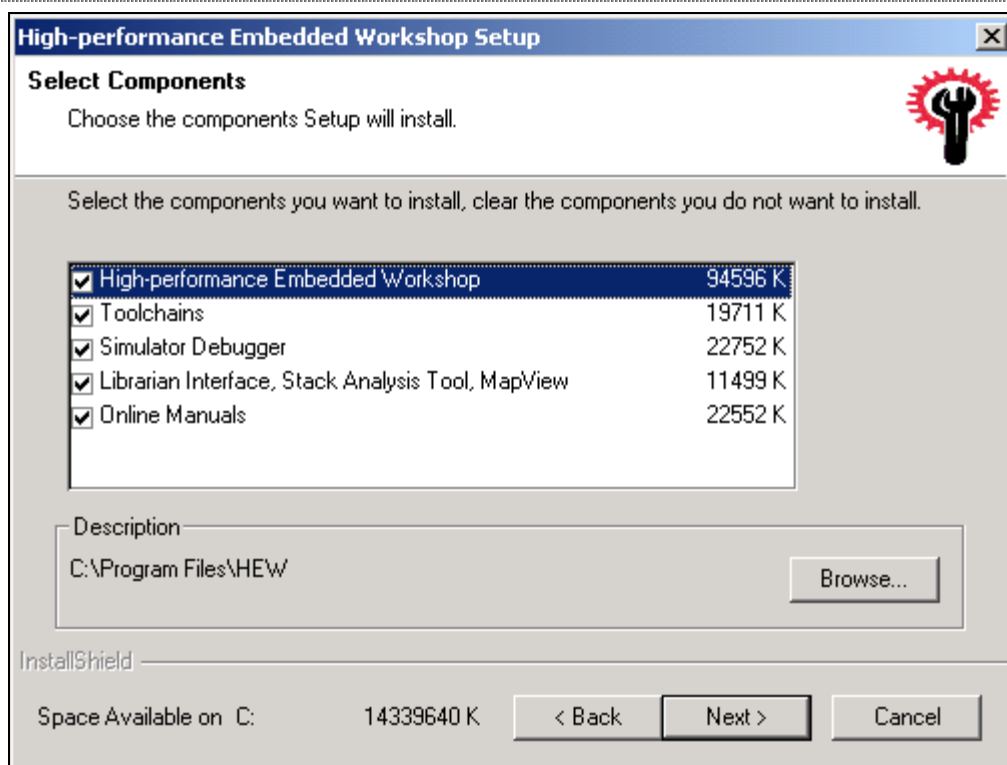

Figure 2-3 Installing HEW package with Tool chain

Note: The location chosen for installation in this example is **C:\Program Files\HEW**

2. Install HEW(Pure Debugger) for CE2000-H8S/2238

Notes : Users have to install in the same location as in Step 1, thus

C:\Program Files\HEW

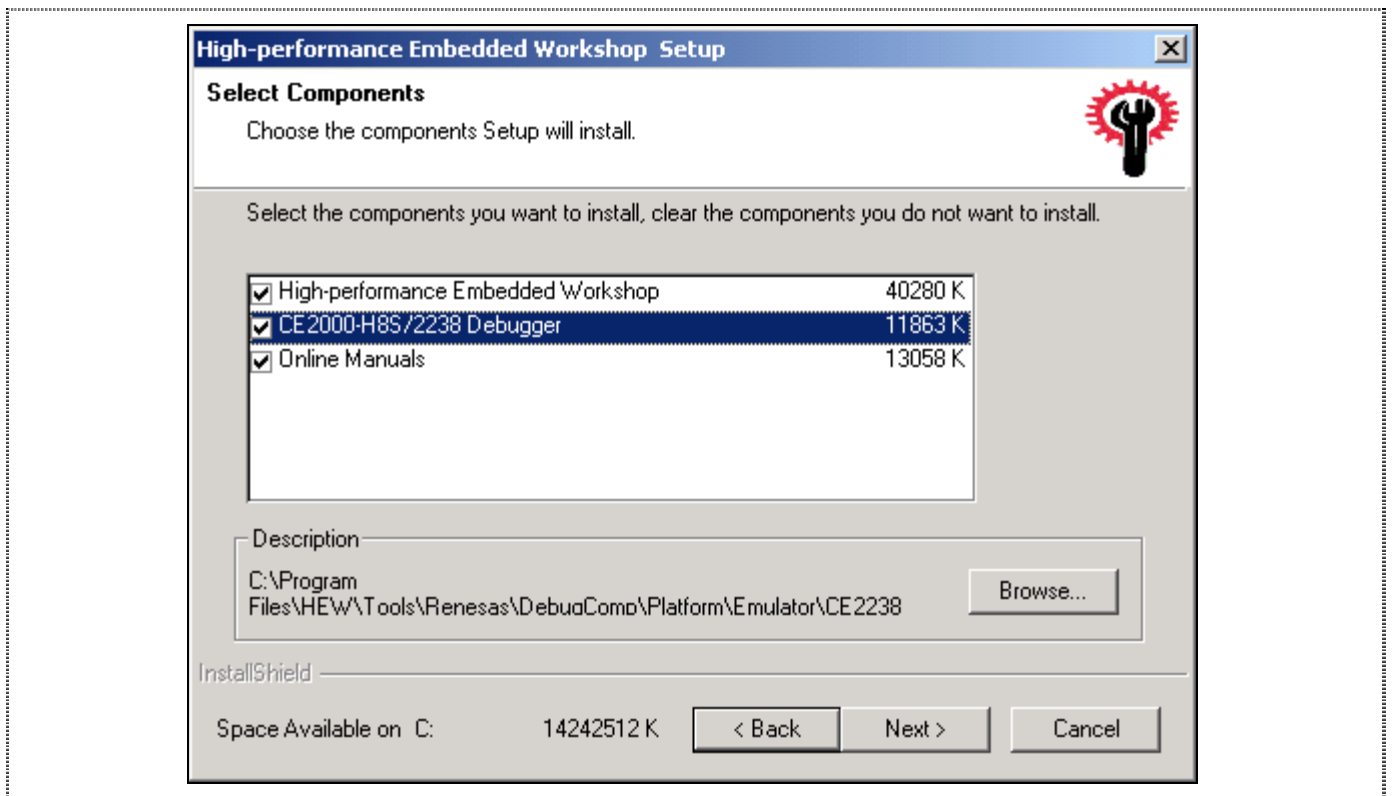

Figure 2-4 Installing HEW(Pure Debugger)

HEW(Pure Debugger) for CE2000-H8S/2238 can be uninstalled by using the **Add/Remove Programs** wizard of **Control panel**.

2.3 Installing the USB Driver

The two methods to install the USB drivers are as follows:

- Select the Add/Remove Hardware in the Control Panel.
- Another method is to link the emulator to the PC through the USB cable. This will activate Windows auto-detect feature.

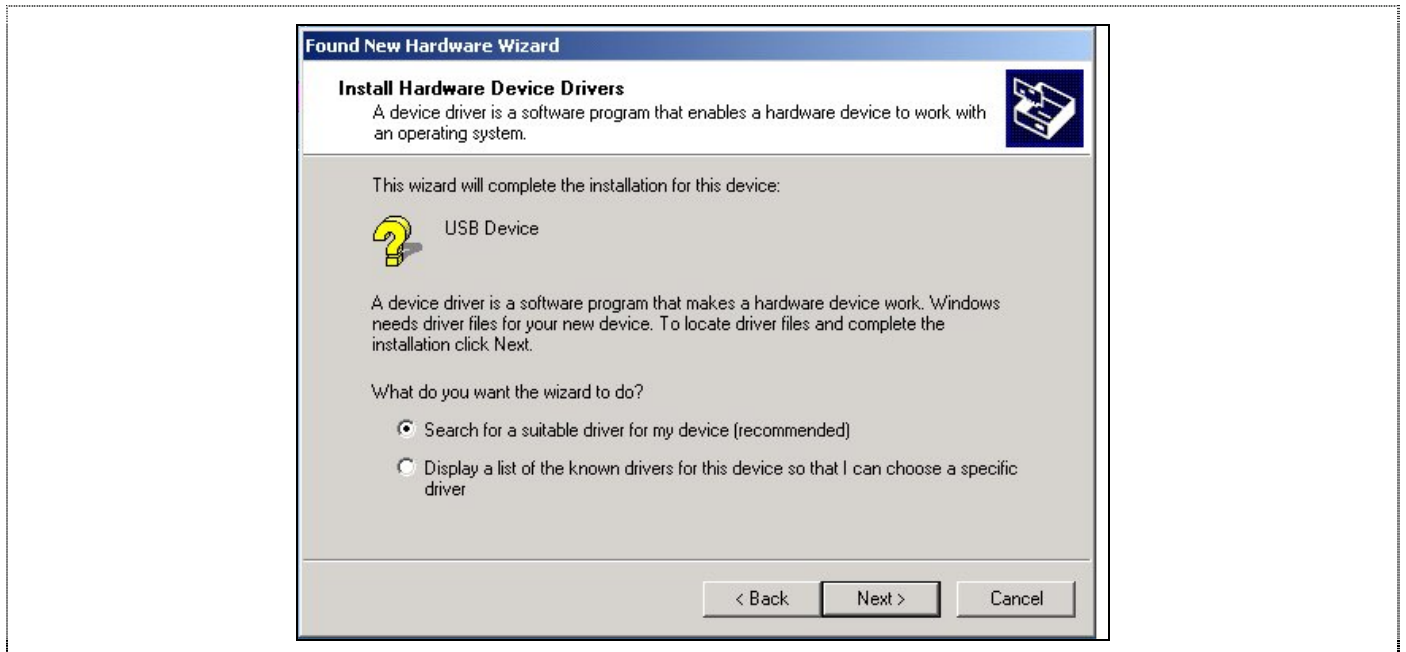

Figure 2-5 Found New Device

- Click *Next* to search for a suitable USB driver



Figure 2-6 Locate Driver Files

- Click *Next* to specify the Driver location

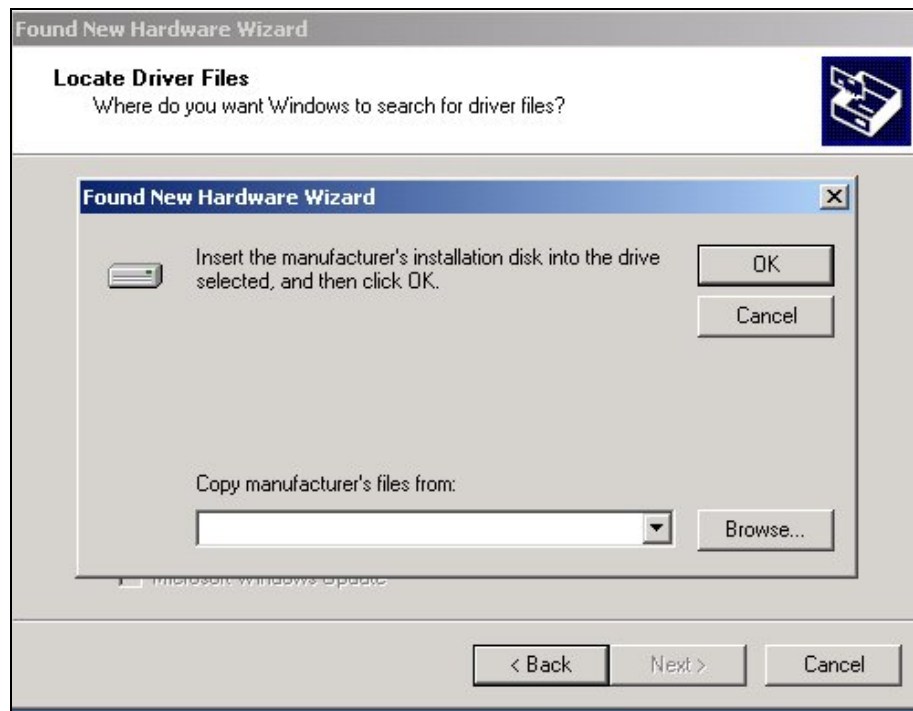

Figure 2-7 Selecting the USB Driver Location

- Click on *Browse...* and select either
- C:\ProgramFiles\hew\Tools\Renesas\DebugComp\Platform\Emulator\CE2238\Driver\Win2K directory or

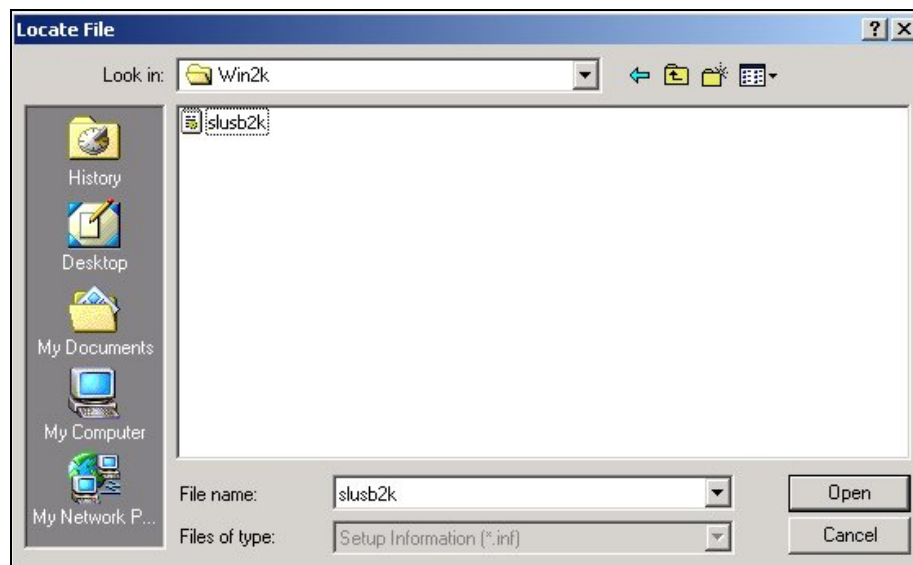

Figure 2-8 Win2K Driver Location

- C:\Program Files\hew\Tools\Renasas\DebugComp\Platform\Emulator\CE2238\Driver\Win9x directory

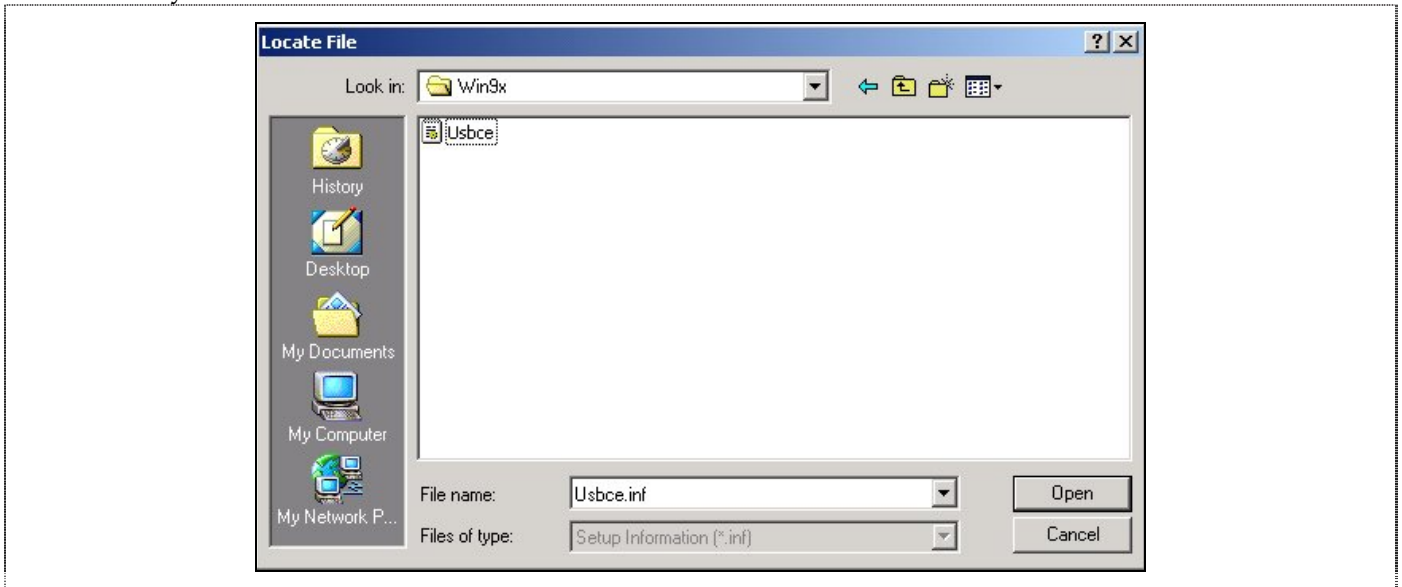

Figure 2-9 Win 9x Driver Location

- Select the file available

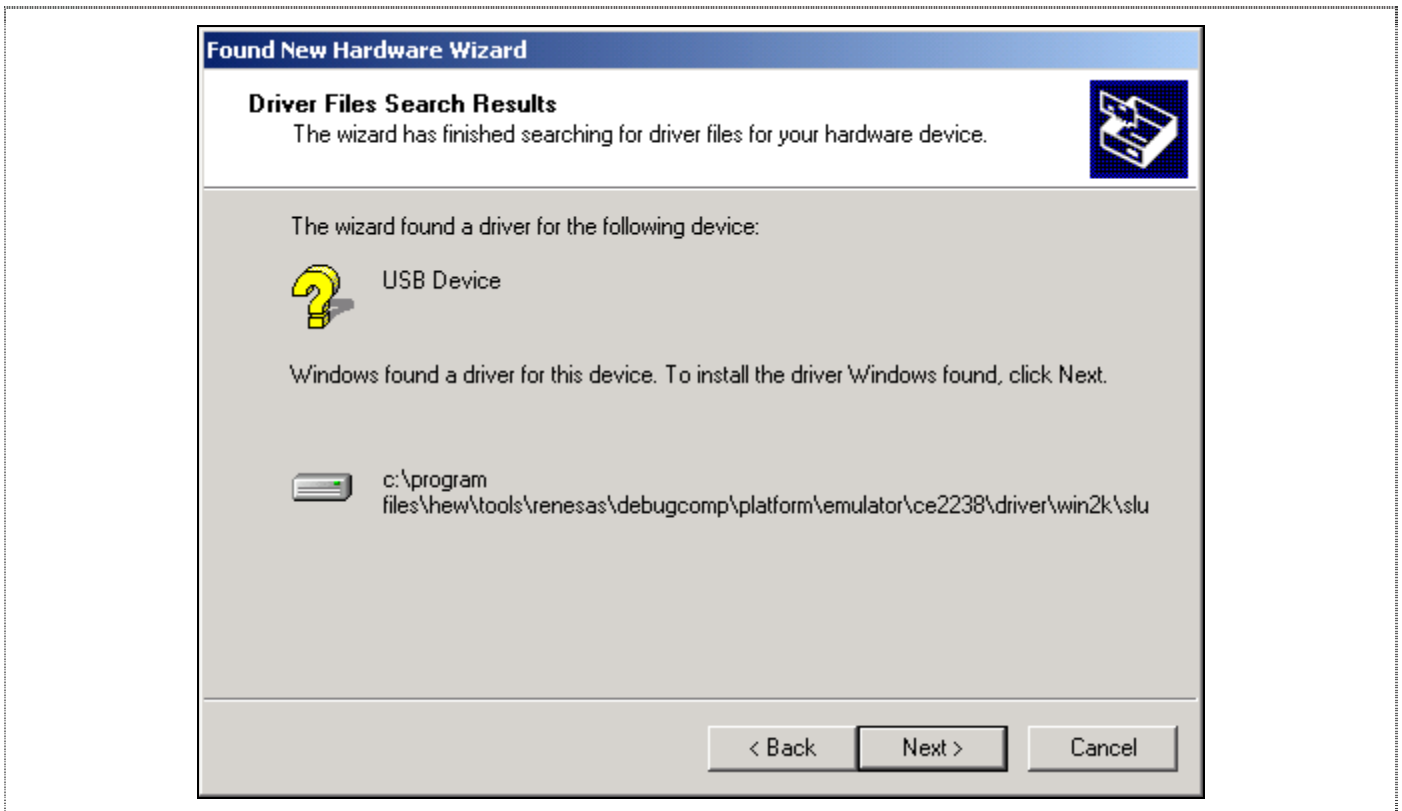

Figure 2-10 Selected Driver File Window

- Click on *Next* to install the driver



Figure 2-11 Compact Emulator USB Driver Installed

- Click on *Finish* to complete the installation

2.4 CE Programmer (OS and Logic Upgrade)

During the installation of the HEW, the installer checks the OS and Logic version of the emulator (if it is connected). If it is outdated, the CE Programmer can be activated to upgrade the OS and Logic through the USB interface (Ensure that the optional memory SODIMM is disconnected).

User can also activate the CE Programmer at any time to upgrade the system. The CE Programmer is located in the "CE Programmer" sub-directory of the directory where HEW is installed.

Step:

- If HEW is connected to emulator, Exit HEW. Restart the emulator with USB connection to PC (This is to ensure that the emulator is in the correct state before the upgrading).
- Click on the *CE Programmer.exe* to activate the programmer.

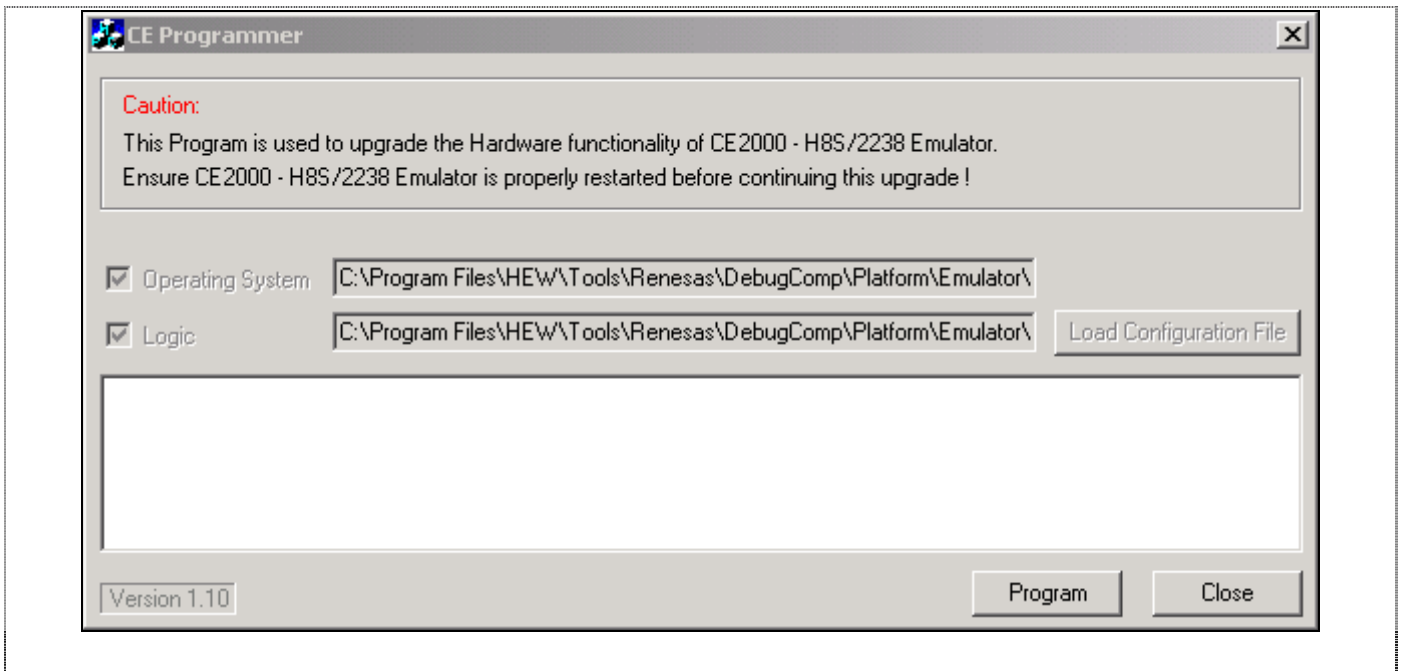

Figure 2-12 CE Programmer Window

- Click on the *Program* button (The OS is programmed first and it takes approximately 25 seconds. This is followed by the Logic, which takes approximately 40 seconds).

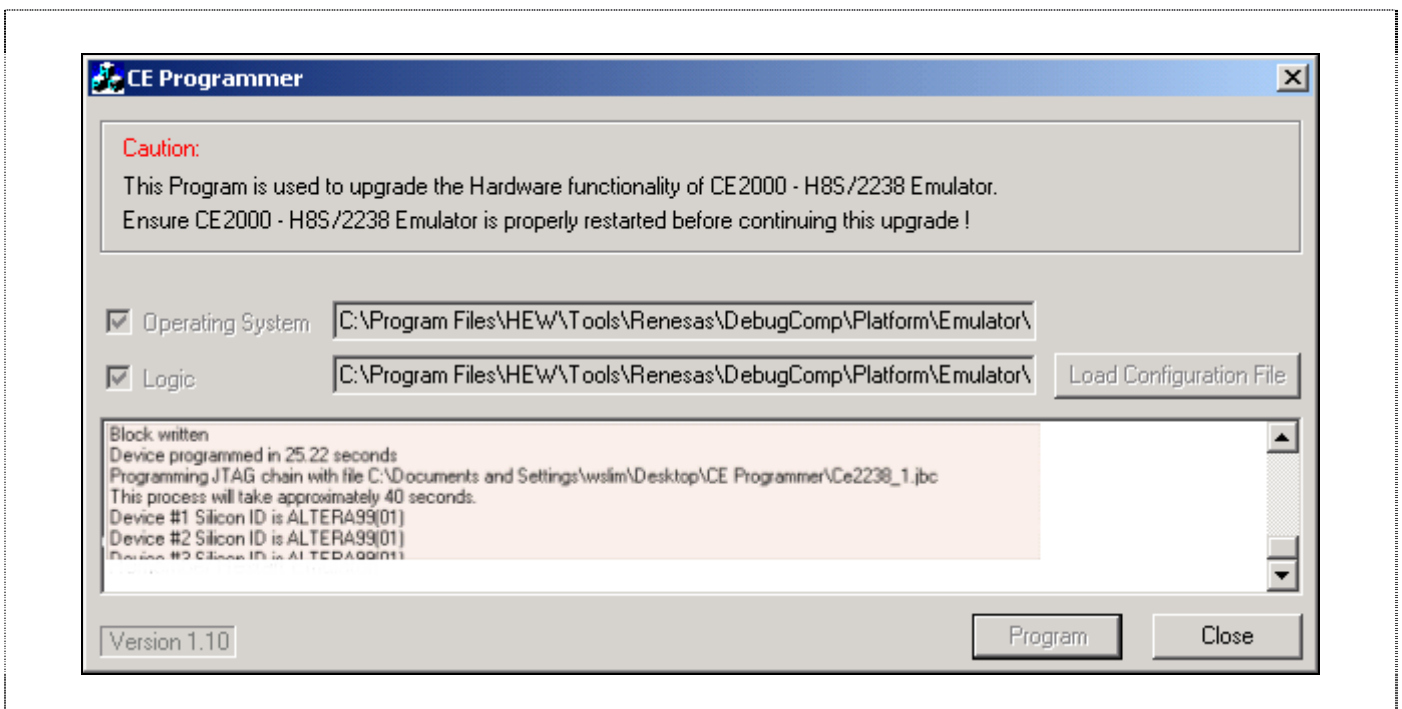

Figure 2-13 CE OS and Logic Programming

- Click on the *Close* button, once the programming has completed.

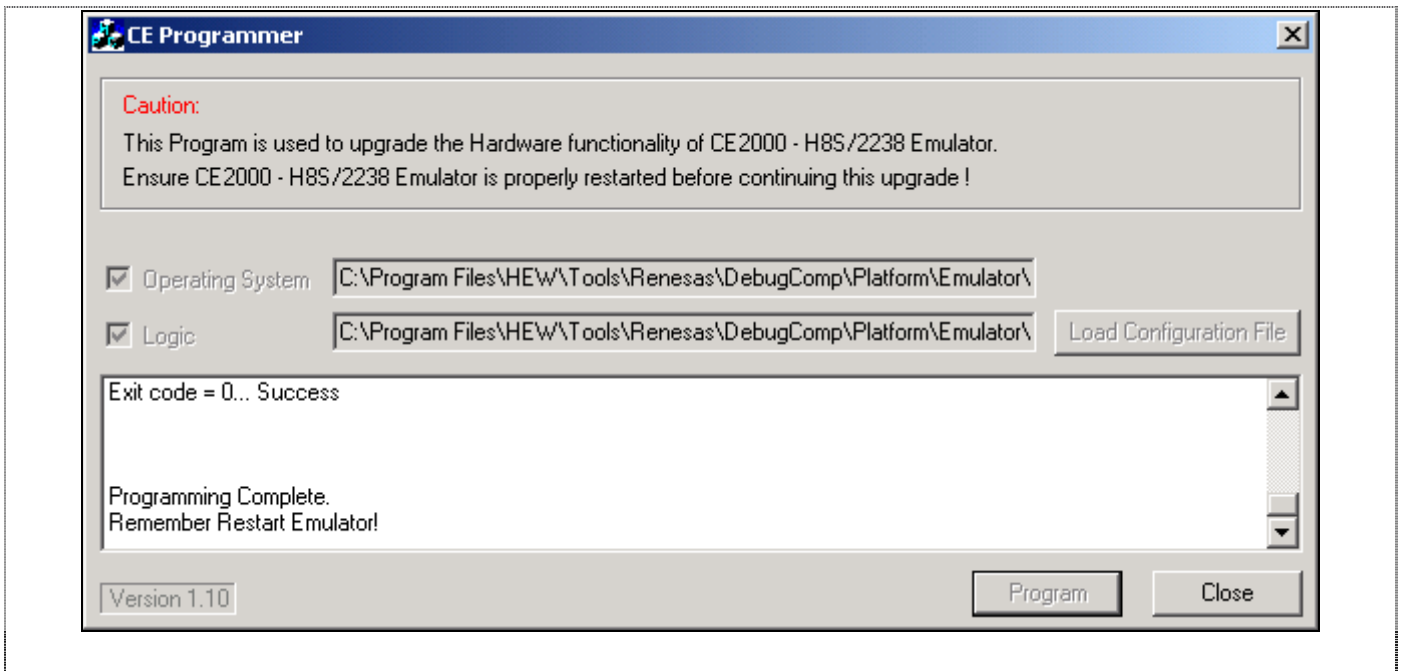

Figure 2-14 End of Programming

- Restart the emulator.

Note:

1. Make sure that there is **no interruption** during the programming. Otherwise, reprogramming will not be possible and user will need to send the emulator back for the upgrade work.
2. The **programming** of the emulator Logic will **fail if the SODIMM is attached**.
3. User can perform the upgrade at any time by executing the *CE Programmer.exe* if necessary.

2.5 Installation Details

The installer creates the following icons in the program group:

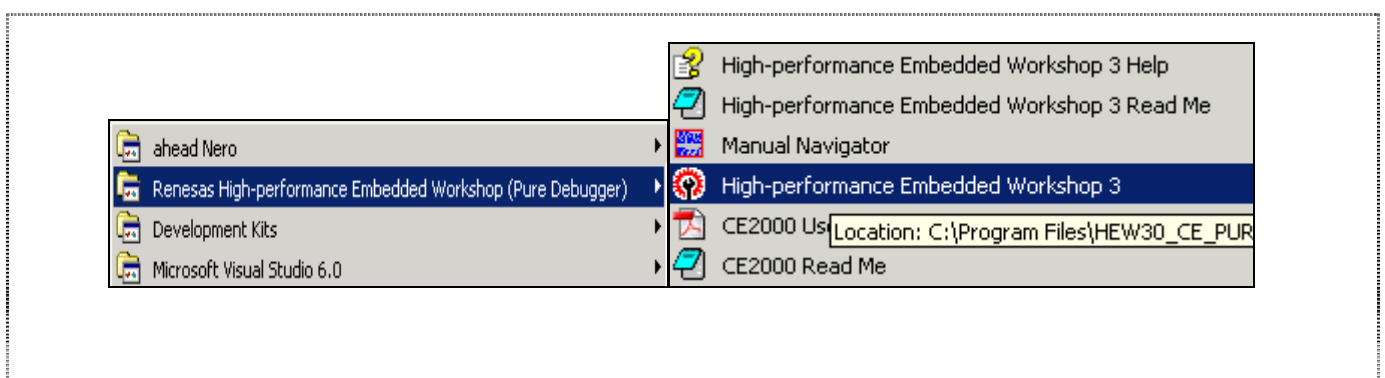

Figure 2-15 HEW Start up Menu

These menu have the following functions:

- | | |
|--|---------------------------|
| “High-performance Embedded Workshop 3” | : HEW will be activated. |
| “CE2000 User Manual” | : User manual for CE2000 |
| “CE2000 Read Me” | : Read Me file for CE2000 |

2.6 Power Up the Emulator

A power supply is included in the CE2000-H8S/2238 emulator package. It can accommodate 110-240V 50-60Hz AC supply. The unit is capable of a regulated 5V, 2.6A output.

The following diagram shows the polarity of the power-supply plug:

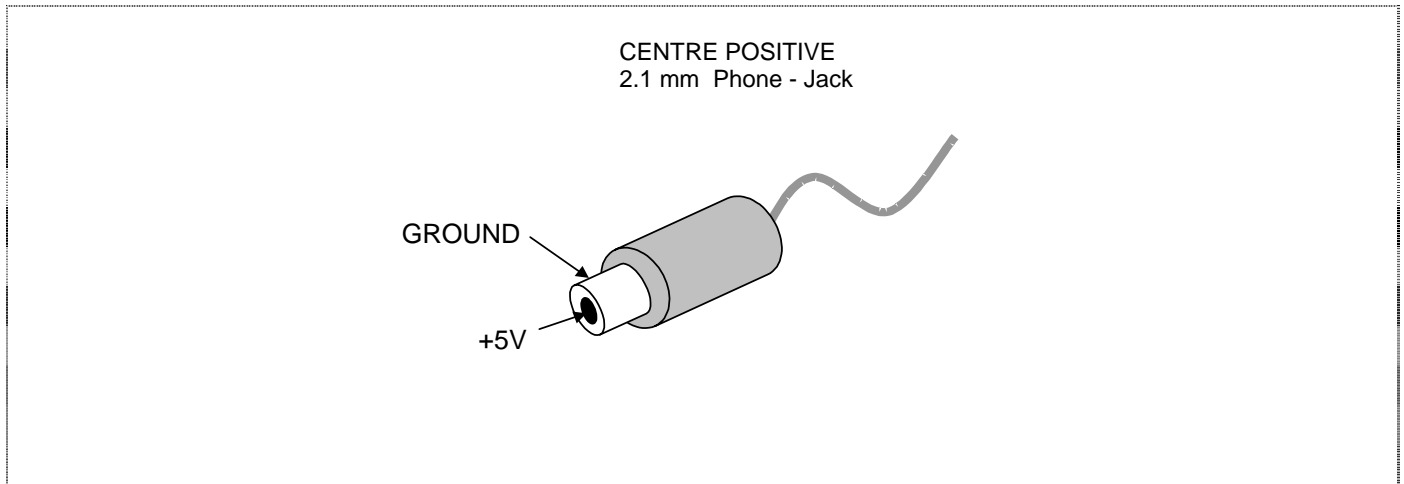

Figure 2-16 Power-supply Plug

Connect the plug to the power input of the emulator. The Power LED lights up (red colour).

2.7 Checking the System (Standalone mode)

If the emulator is powered up and USB link to PC is not established within 10 seconds, it will go into self test mode.

The POWER LED changes its colour from RED to ORANGE when it has entered the self test mode. This test takes about 1~2 minutes. At the end of the test, the POWER LED starts to blink. If the test fails, the adjacent RUN LED lights up in RED. Otherwise, it remains unlit.

For more details about this test, please refer to section 8.

After the confirmation of the condition of the emulator, user has to insert the USB cable and power up the emulator in order to link the emulator to the PC.

2.7.1 LED indication

Indication	POWER LED	RUN LED
Power Up	Red	Nil
Self Test in Process	Orange	X
Self Test Fail	Blinking Orange	Red
Self Test Pass	Blinking Orange	Nil
Running User Program	X	Green
PC Detection	Orange	X

X : Don't Care

2.8 Activation of the Emulation System

To activate the emulation system, user has to:

- Ensure that the CE2000-H8S/2238 emulator is powered up i.e., check that the POWER LED is illuminated and the colour is RED.
- Ensure that the USB cable is linked between the emulator and PC.
- Select the HEW start up menu.

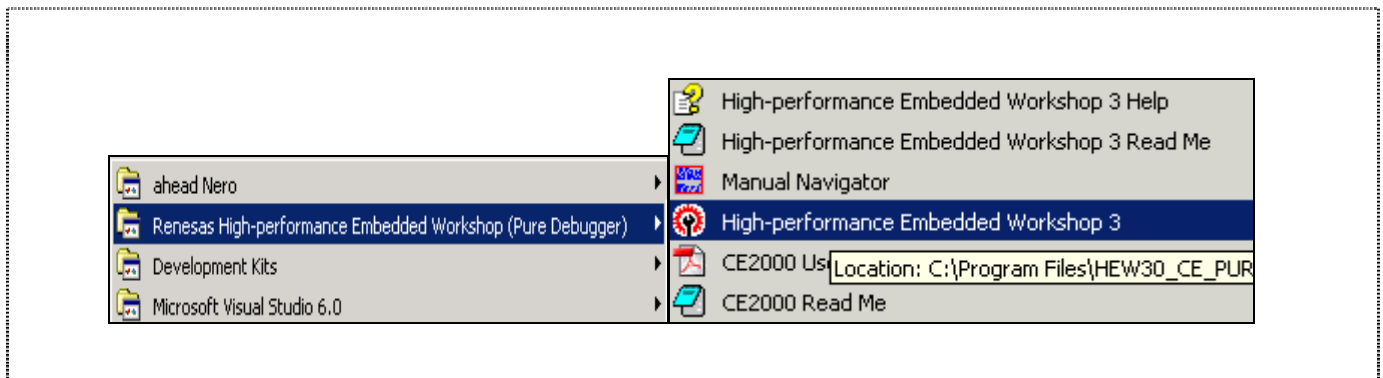

Figure 2-17 Execute HEW from Start Menu

2.8.1 Creating new workspace

A new project workspace can be generated for device of H8S/2238 Series by clicking menu **File->New workspace** as figure below.

Proceed with other steps and chose the CPU Series **2000** and the device supported by **HEW(Pure Debugger) for CE2000-H8S/2238**. And, select Target “**CE2000-H8S/2238 Emulator**” in dialog “**New Project – Step 7**”.

Note:Select Toolchain “**Hitachi H8S,H8/300 Standard**”.

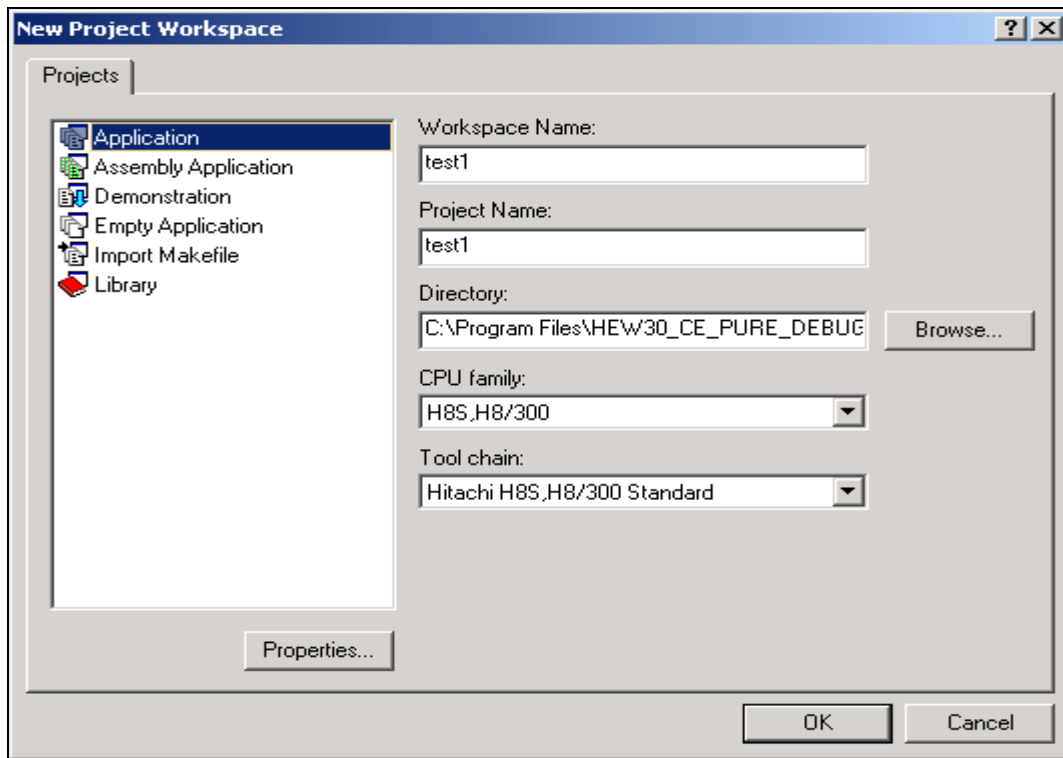

Figure 2-18 Creating new workspace

2.9 Configure the Platform

Before any emulation can proceed, user is advised to configure the platform for the desired application. This will ensure a proper control over the targeted application.

All the following can be configured by selecting menu *Options->Emulator->Systems....*

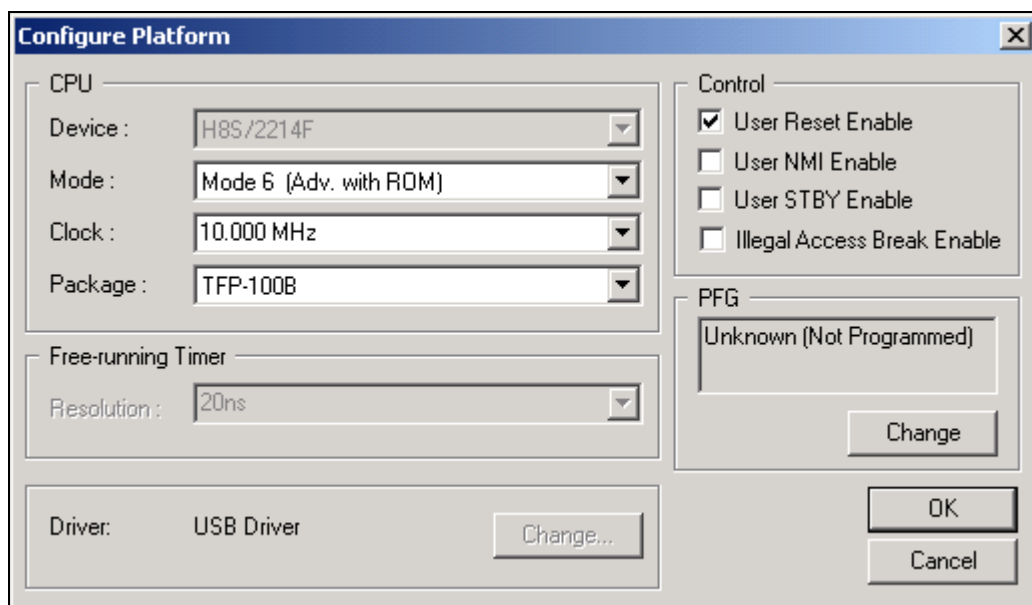

Figure 2-19 Configure Platform dialog

Figure 2-19 shows the **Configure Platform** dialog for platform configuration.

2.9.1 Device and Package Selection

User has to select the desired device and package. The selection will determine the mapping window setting. The package selection will also determine the type of graphical display in the pinview window.

2.9.2 Operating Mode Selection

There are five mode selections:

- Mode 4
- Mode 5
- Mode 6 [Default]
- Mode 7
- Target Mode : determined by USER Target system via user cable

NOTE: For ROMless mode operation, user has to make sure that external memory is connected before any emulation can occur. If user's target system is not ready, user may map the area to the optional SODIMM memory for temporary usage.

2.9.3 Clock Selection

User can choose from two different sources: Internal or External Target Clock.

For internal clock, user can key in any frequency from 1MHz to 25MHz, in the step of 100KHz (*in Options->Emulator->Systems ...*). The emulator will generate the requested clock for the running processor.

For external target clock, user can either input an oscillating clock into the EXTAL pin, or place a crystal at the actual footprint user cable (EXTAL and XTAL pins).

2.9.4 User Signal Masking Control (RESET, NMI & STBY)

These signals can be masked by the emulator when user executes the programs. At startup, the RESET and NMI signals are not masked, whereas STBY signal is masked (*in Options->Emulator->Systems ...*). Illegal access break can also be enabled in this dialog.

NOTE: If STBY signal is asserted during user run mode, the emulator will enter standby mode, and the emulator control registers are initialised.

2.9.5 Downloading of Emulation Function (Programmable Function Generator)

User has to download the selected function to the Programmable Function Generator before it can be used. This has to be done once the emulator is switched off.

Please refer to section 3 for more details.

2.10 Memory Mapping

After the selection of Device, Package and Mode, the default mapping will be generated. This can be viewed under the *Options->Emulator->Memory Resource....*

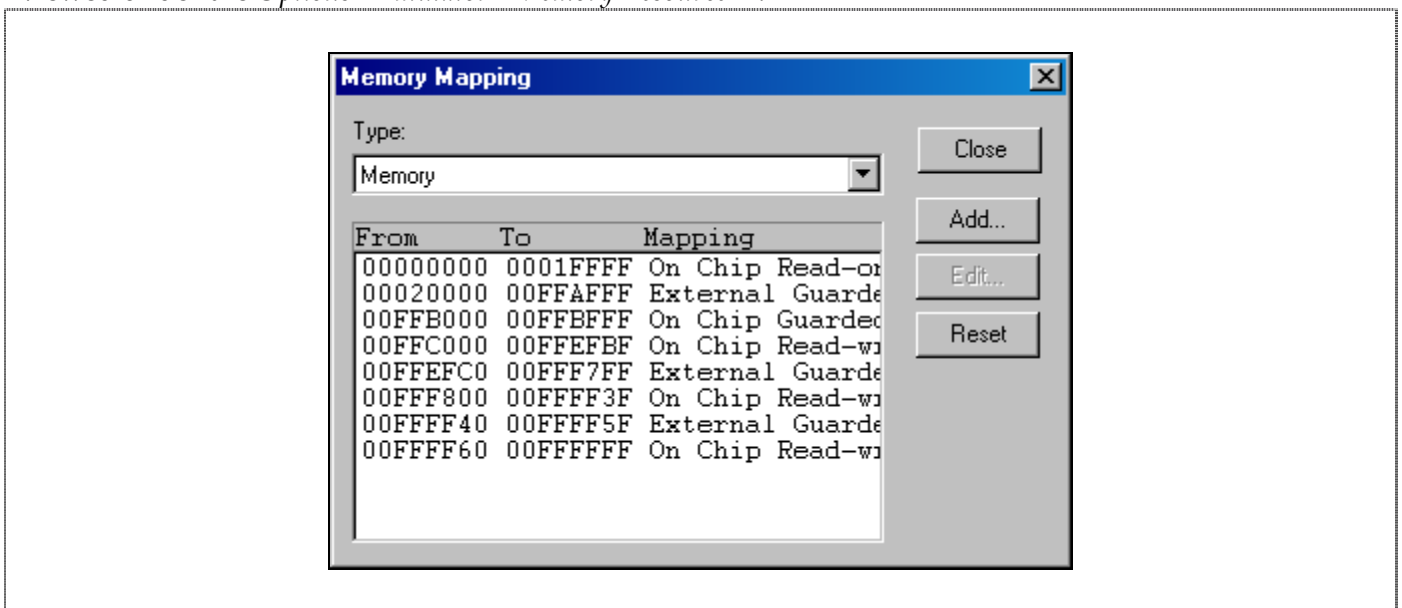

Figure 2-20 Memory Mapping dialog

Usually, user does not require to change this setting. However, it may be changed for the following reasons:

- Addition of target system with memory
- Addition of optional SODIMM memory

The nine available attributes are:

- On Chip Read Write
- On Chip Read Only
- On Chip Guarded
- Emulator Read Write
- Emulator Read Only
- Emulator Guarded
- External Read Write
- External Read Only
- External Guarded

To change the setting, user has to:

- Click on the *Add* button in the *Memory Mapping dialog*.
- Key in the desired address at *From* and *To*.
- Select the attribute.

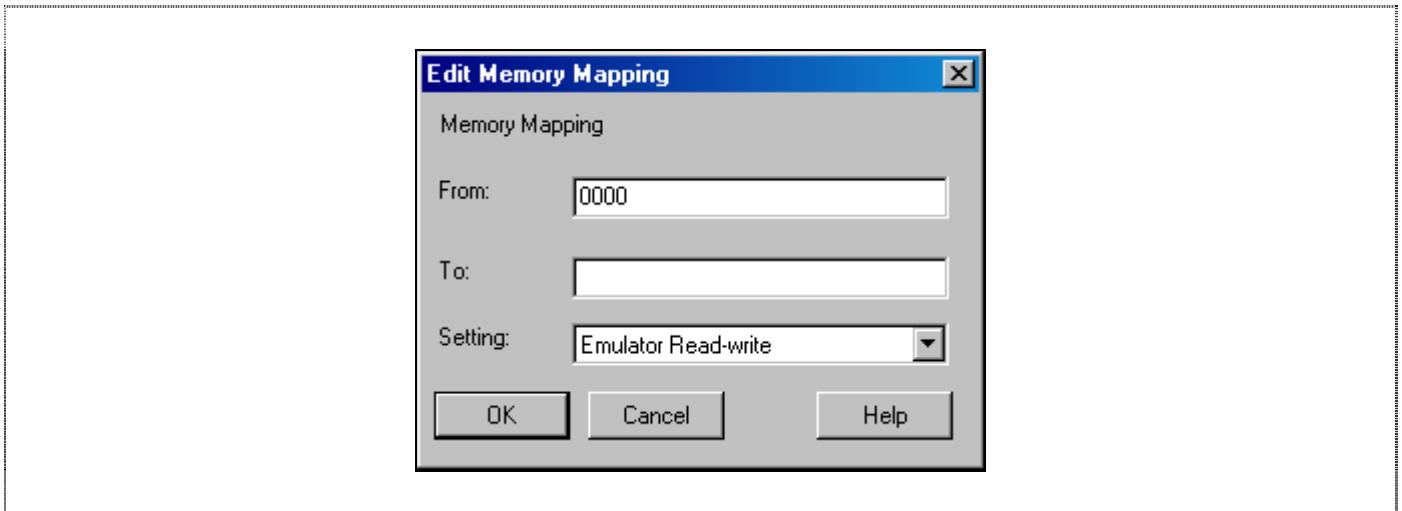

Figure 2-21 Editing the Memory Mapping

For the details of the memory mapping, please refer to section 3.

2.11 Connection to Target System

2.11.1 Target Power Supply

The CE2000-H8S/2238 emulator has an automatic voltage follower. Once target is connected (target connector's signal: CABLE_IN_N = Lo, refer to the Appendix A), the CE2000-H8S/2238 emulator will operate at the user supply (2.5V–5V). Otherwise, it will operate at 5V. When target is connected, HEW will indicate "User Cable : connected" in the *status/ platform* window.

NOTE:

- Do not connect the user system interface cable to the emulator without user system connection (i.e. without target user supply).
- Turn on the user system before powering up the emulator.

2.11.2 Types of User Interface Cable

There are two ways to connect the target system to the CE2000 i.e.,

- via an actual footprint user cable (purchase separately), or
- direct connection using the KEL connectors (supplied in the package)

For the actual footprint user cable, user is advised to refer to the Microcomputer Hardware Manual for the footprint information.

For the direct connection method, the connector information such as pin definitions, layout, dimensions and part number are detailed in the Appendices A, B and C.

For Direct Connection,

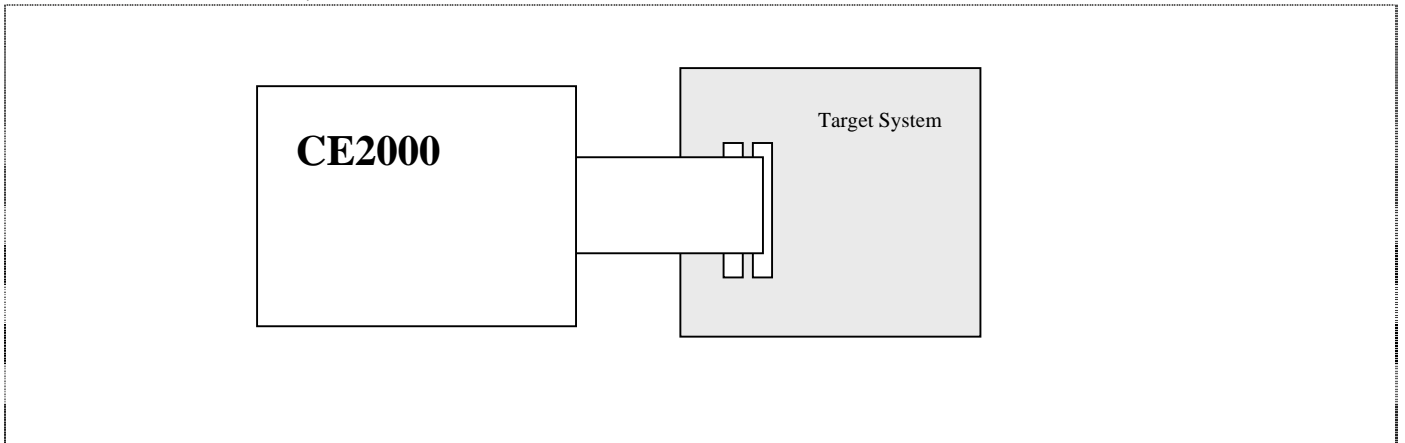

Figure 2-22 User Interface Cable - Direct Connection

NOTE: User has to connect the signal CABLE_IN_N to ground.

For Actual Footprint.

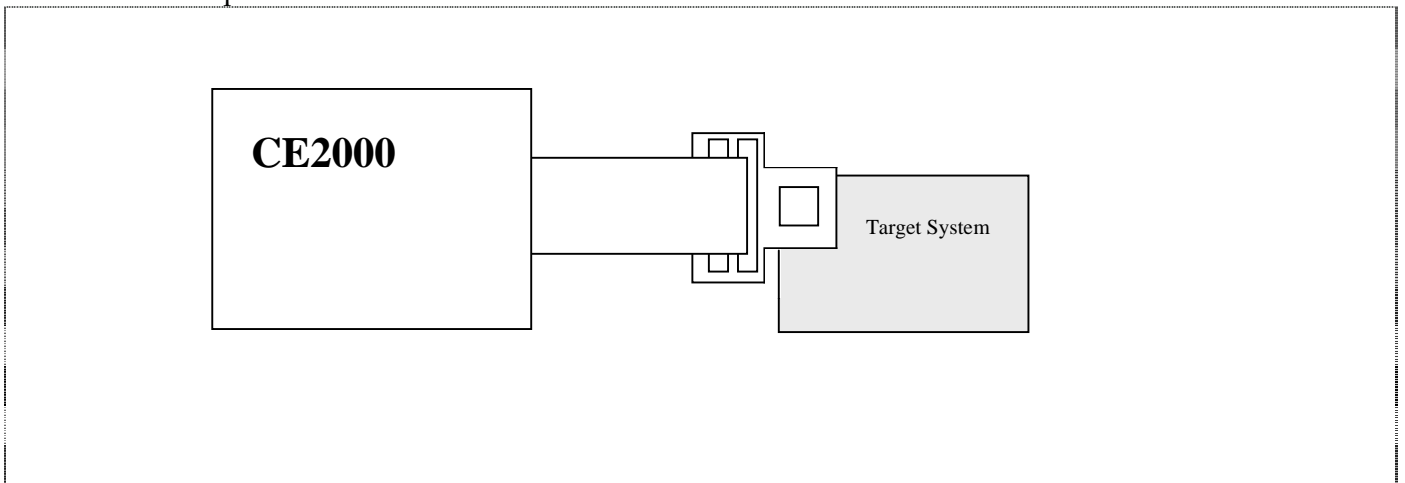

Figure 2-23 User Interface Cable - Actual Footprint

2.12 Optional SODIMM Memory Selection

Optional SODIMM memory is used when user wants to access external memory area when the target system is not available.

If SODIMM is purchased, user has to open the casing and fix the SODIMM in the correct socket (Please refer to the SODIMM user manual).

In order to use the SODIMM, user has to enable the memory at the desired address:

- In the *Memory mapping* dialog, click on *Add*.
- Key in the desired address at *From* at *To*.
- Select the attribute i.e., Emulator read-write, Emulator read only or Emulator Guarded.

NOTE: 2Mbytes (Four banks of 512 Kbytes) of Optional Memory (purchase separately) can be used in the CE2000-H8S/2238 emulator. User can map the memory (minimum of 32 Bytes to a maximum of 2MBytes) to any space except internal space (e.g. internal ROM, RAM, peripherals, ...). If the target memory is present in the same area as the optional memory, the optional memory will have a higher priority to be accessed.

e.g. If user maps the address from H'20000 to H'80002 as Emulator-Read-Write, HEW will allocate 2 banks of memory for the user, to access from area H'20000 to H'8001F.

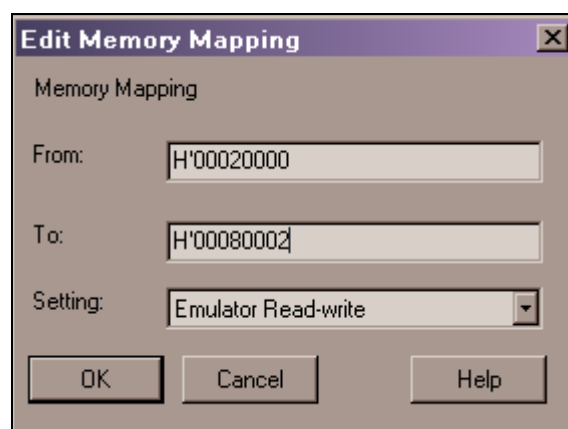

Figure 2-24 Addition of Optional Memory Address Range

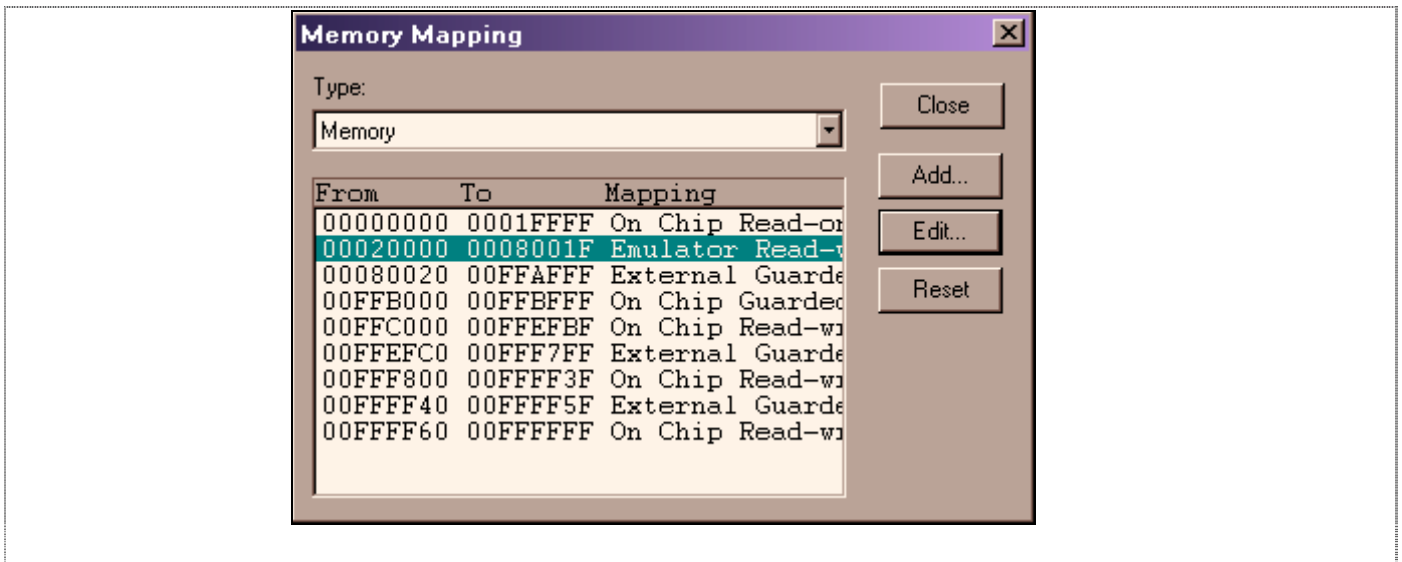

Figure 2-25 Memory Mapping Window

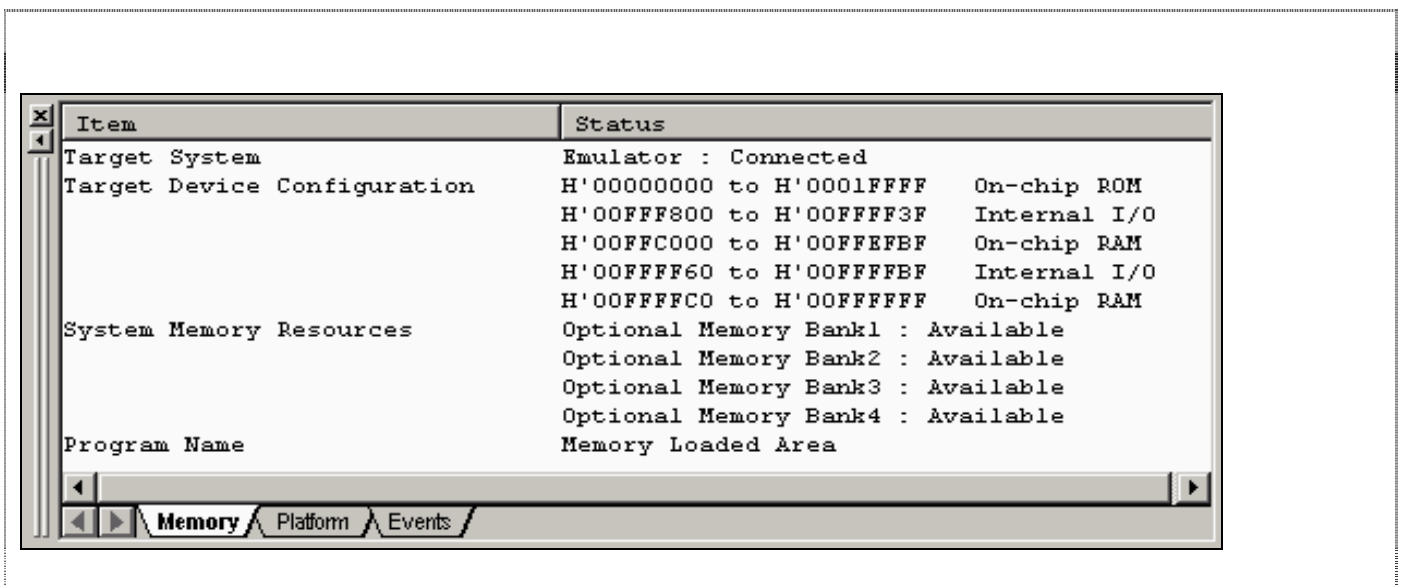

Figure 2-26 Mapping of Optional Memory Shown in Status Window

The *Memory* page of *Status window* in **Figure 2-26** details the usage of the different banks of optional memory.

Please refer to *Section 3.13* for the details in Memory Mapping setting.

- Blank Page -

Section 3. Emulation Functions

3.1 Overview

3.1.1 Emulation

The CE2000-H8S/2238 emulator operates in two modes: *Break* and *User* modes.

To execute the user program, user can either *Single-Step*, *Run at current program counter* or *Reset Go*. This will cause it to operate in the *User mode*. To terminate the User Run state, a break condition has to be asserted to bring the emulator to the *Break mode*. This can either be a preset condition(eg. PC Break, Event Break) or a force break condition (Hit ESC key).

During Break mode, user can manipulate their target system & memory by accessing the I/O, Memory ... windows.

During Run mode, information such as accessed address, CPU states (e.g. instruction fetch cycle, sleep mode...) and run time can be observed. User can also view and edit the memory contents in the internal ROM/RAM or optional SODIMM area. This process is named as Parallel On the Fly (POTF).

3.1.2 High-performance Embedded Workshop(HEW)

The following figure is a snap shot of the HEW desktop window.

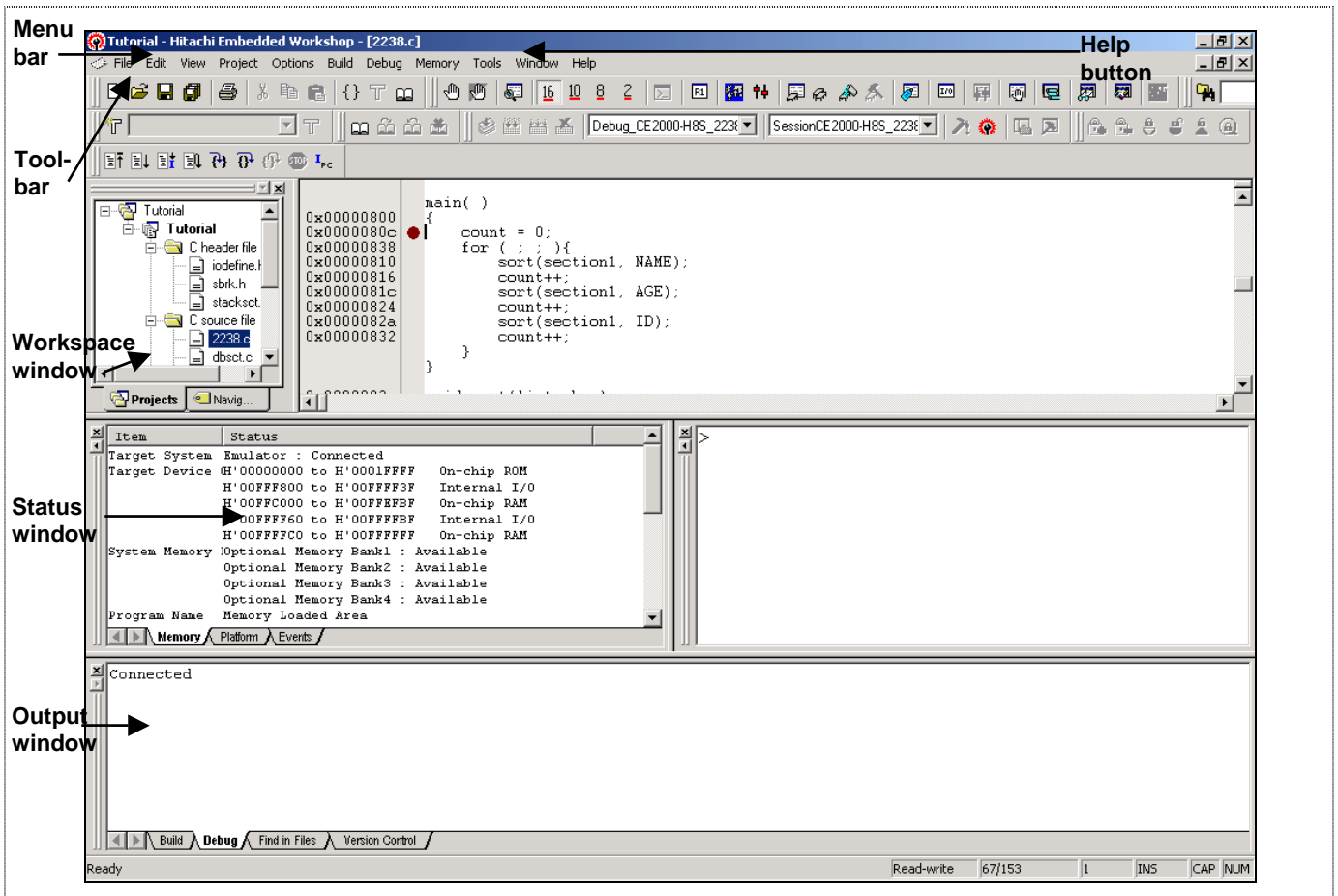

Figure 3-1 HEW desktop window

The key features of HEW are described in the following sections:

- Menus** : Gives user access to the HEW debugging commands for controlling CE2000 Emulator.
- Toolbar** : Provides convenient buttons as shortcuts for the most frequently used menu commands.
- Workspace Window** : Displays the list of source files.
- Output window** : Displays the status of debugger, building process, etc...
- Help Button** : Activates context sensitive help on any feature of the HEW user interface.

3.2 Programmable Function Generator (PFG)

This allows user to download the desired emulation function during debugging (*in Options->Emulator->System...*). At the power-up state, there is no function in the PFG and user has to download the preferred function before emulation. User can only change the function when the emulator is in break mode. To access the function after downloading, user has to open up the break or trace window. The programmed function will remain in the emulator as long as it is not powered down.

As at the current date, the available function is the “Integrated 256 Cycles of Bus Trace and Two Event Breaks”. More functions will be generated later. Please approach the relevant Renesas Sales Office for further information.

3.3 Pin View

Pin View module shows the pin-state of device in graphical and text forms.

3.4 Go (Reset Go, Go at PC, Goto Cursor)

Real-time execution (*in Debug/Go*) by the H8S chip based on the user setting. There is no “cycle steal” during the execution mode.

3.5 Reset CPU

When “RESET CPU” command is activated, the following actions will take place,

PC	=	Power on Reset vector value
ER7	=	H'FFEFBC
ER0-6	=	H'0
CCR	=	H'80
EXR	=	H'07

The microcomputer is reset.

3.6 Single-Step

There are four types of Single Step:

- Step-In,
- Step-Over, Step-out,
- Step...

Single Step executes the instruction at the current program counter. If an interrupt is asserted, the interrupt service routine will not be serviced unless a “Go” commands is issued.

Step-In will execute a single instruction only. For C source file, a single step will execute a “single C source code”. Whereas for an assembly file, a single step will execute a single assembly instruction code. Step-Over executes multiple Step-In to complete a function execution until it has reached the next instruction.

Step-out performs program stepping out of a function.
 Step... will execute multiple Step-in as specified by the user.

3.7 Break Functions

Breaks are events used to interrupt the normal program execution when a specific condition is matched. There are six types of break in CE2000. These break functions are classified into two classes, mainly hardware Event and software PC break.

For Hardware Event break, the preset break condition will cause the break event to occur after an instruction is executed. For Software PC break, the break condition causes the break event to occur before the break condition.

Table 3-1 Types of Breaks Encountered During Emulation.

	Types of Break	Description
1	Event Break** (Hardware Break)	A break occurs when the CPU matches with a condition specified in the Breakpoint Setting dialog, or when the pre-fetch cycle of the CPU agrees with the specified states.
2	PFG Break (Hardware Break)	A break occurs when the CPU matches with a condition specified in the Breakpoint Setting dialog, or when the pre-fetch cycle of the CPU agrees with the specified states.
3	PC Break (Software Break)	A break occurs at the program address specified in Breakpoint Setting dialog. The instruction at this address is replaced with a system instruction before the execution of code. If a PC breakpoint is detected, the emulation stops at the specified address before executing the subsequent instruction.
4	User Break	Pressing the ESC key of the host PC generates a break.
5	Reserved Area Break	A reserved area break occurs when user code reads from or writes to prohibited area of the MCU memory map
6	Write Protect Break	When ROM in the MCU is specified, a write protect break occurs when attempting to write to the ROM area.

** under development

3.7.1 Event Breakpoint

For the CE2000-H8S/2238 emulator, two event breakpoints are supplied permanently. The conditions to determine the breaks are

- Address
- Access (Read/Write)

The break condition occurs in a “AND” condition. If the factors defined are not fulfilled, the particular break condition will be ignored. Each factor can be masked or ignored.

Since the event breakpoint is still under development, user can use the PFG Breakpoints instead.

3.7.2 PFG Function - PFG Breakpoint

Two PFG breakpoints can be downloaded into the PFG. The PFG Event Breaks have the following conditions:

- Address
- Data
- Access (Read/Write)

3.8 Run Time Measurement

The run time counter is set to measure the instances when the user program is executed. The resolution of the timer is 50ns. There is no time limit for this counter.

The runtime can be observed in the Status window during the run mode.

3.9 PFG Function - Trace

There is no permanent trace provided. However, user can download the Trace Function into the PFG to keep track of the program. The Trace provided is a 256-cycle trace. The Trace function will display the last 256 cycles of information upon encountering a break condition.

In each trace cycle, the available displayed data are

- 24-bit Address
- 16-bit Data
- Read / Write
- MCU status
- The Executed Code (C or assembly)

3.10 Memory Functions

General functions such as fill, copy, search, save and load memory are supported, by means of clicking the mouse button. Modification of memory can be made via byte, word, or long word access.

NOTE: User has to set the bus state controller correctly before the external memory can be accessed.

These functions can be applied on all the three memory type of the emulator, namely:

- On-Chip Memory (internal ROM/RAM)
- Optional SODIMM Memory (2Mbytes SRAM)
- User Target Memory

3.11 Parallel-On-The-Fly (POTF)

POTF feature can be observed in the Monitor window in HEW.

3.12 Memory Mapping

This functions as a traffic controller to direct the MCU to access the intended area of memory. In general, there are three types of memory area, namely:

- On Chip Memory
- Optional Emulator Memory
- External Target Memory

Two more constraints are set to prevent user's program from running wild. i.e.

- Write-protect
- Access-inhibit or Guarded

These protections can be allocated to the memory area in minimum unit of 32 bytes resolution.

These constitute nine possible attributes setting:

- On Chip Read Write
- On Chip Read Only
- On Chip Guarded
- Emulator Read Write
- Emulator Read Only
- Emulator Guarded
- External Read Write
- External Read Only
- External Guarded

To change the setting, user has to:

- Click on the *Add* button in *Memory Mapping* dialog.
- Key in the desired address at "From and To". &
- Select the attribute.

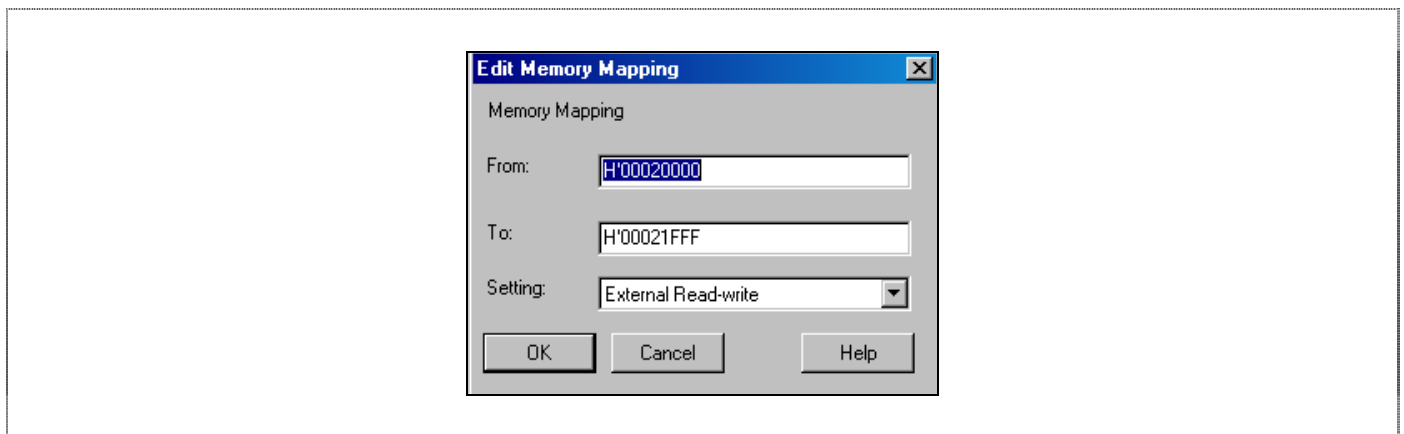

Figure 3-2 Modification of Mapping Memory

At startup, when user select the *Device*, *Package* and *Mode* in the *Configure Platform* dialog, default mapping for the application will be generated. This can be viewed under *Memory Mapping* dialog. In default, if the device has an external address space, it will be set to be *external guarded*. Upon connecting the emulator to a target system or accessing the optional SODIMM, user has to change this default setting i.e.,

To access external target memory

- Set *External Guarded* to *External Read Write* or *External Read Only*

To access optional SODIMM memory

- Set *External Guarded* to *Emulator Read Write* or *Emulator Read Only*

For the *On Chip* attributes, user can only change the attributes from Read-Write and Write to Guarded, but not at any other possibilities. In the case for the *Emulator* and *External* attributes, user can set it to any combination.

3.13 CPU and I/O Registers Access

User can access these registers directly through the Register and I/O windows respectively during break mode only.

3.14 Session

User can retrieve the last emulation environment by saving and restoring session. HEW will load the same session, which comprises of the following:

- Mode settings
- Window positioning
- File loaded
- Clock settings
- Registers value settings
- PFG function loading

3.15 C-source Level Debugging

If user compiles and links the code with the Debug option enabled, the Renesas object format (.abs) file with the debugging information is generated. This enables user to debug the code in C-source level i.e. ,

- Display code in C source level,
- Step code in C source level,
- View label,
- Goto label (address),
- View local
- Add watches

Section 4. H8S Function Supported

The CE2000-H8S/2238 emulator can support the H8S series of microcomputer. The various functions support for the H8S are detailed below.

4.1 MCU Operating Mode Setting

The CE2000-H8S/2238 emulator supports the four operating modes of the H8S. User can select the MCU operating mode via the *Configure Platform* dialog. The following table shows the MCU settings.

Table 4-1 MCU Operating Modes

Operating mode	MD2	MD1	MD0	
Mode 4	1	0	0	Advanced expanded mode w/o internal ROM (16 bits)
Mode 5	1	0	1	Advanced expanded mode w/o internal ROM (8 bits)
Mode 6	1	1	0	Advanced expanded mode with internal ROM
Mode 7	1	1	1	Advanced single chip mode

4.2 Memory Area

The H8S has a maximum memory area of 16 Mbytes. The four classification of memory are:

4.2.1 Internal ROM Area

The emulator has a substitute RAM for the H8S internal ROM. Access to this substitute RAM is as follows:

- Access arising from user program execution : Read only, write disabled
- HEW : R/W enabled

Therefore, the user can modify the internal ROM area memory and load the object program.

4.2.2 Internal RAM Area

The emulator has a substitute RAM for the H8S internal RAM. When user tries to access the internal RAM, this substitute RAM is always accessed instead. User can access the internal RAM area from the user program or with an HEW.

4.2.3 Internal I/O Area

When the internal I/O area is accessed, the emulator accesses the internal I/O. User can read and write to the internal I/O area from the user program or with HEW.

4.2.4 External Area

The external target area will be accessed as long as the area does not belong to:

- Internal ROM
- Internal RAM
- Internal I/O
- Mapped Emulator Optional Memory

User has to set the area to be read/write or write protected, in order to access the area. Otherwise, the area will be treated as Access inhibited or Guarded.

The number of accessing states and type of access (e.g. DRAM access) will be determined by the H8S registers (eg. BSC, WCR1...).

4.3 Low Power Mode

For reduced power consumption, the H8S has medium speed, sleep, module stop, hardware standby, and software standby mode

4.3.1 Hardware Standby Mode

The hardware standby mode is switched by the STBY signal input. This signal will initialise the emulator registers. In default, the STBY signal is masked in the *Configure Platform* dialog.

The status of the STBY signal from the user's target system can be monitored by HEW.

4.3.2 Sleep and Software Standby Modes

The sleep and software standby modes are switched using the SLEEP instruction. These modes can be cleared with either the normal clearing function or with the break condition fulfilled (including 'ESC' key input). The program will then be put to a stop.

Trace information is not acquired in sleep and software standby modes.

NOTE: When restarting after a break, the code after the SLEEP instruction will be executed.

4.3.3 Medium Speed and Module Stop Modes

These modes are switched by the setting of the I/O registers in the MCU and not controlled by the emulator.

4.4 Interrupts

During emulation, the user can interrupt the H8S. If an interrupt occurs while the emulator is in the break mode, the interrupt is not processed. However, if an edge-sensitive interrupt occurs while the emulator is in the break mode, the emulator latches the interrupt and executes the interrupt processing routine when the GO command is instructed again.

Interrupt request is masked during single step.

4.5 Control Input Signals (RES, NMI, STBY)

The H8S input signals (RES, NMI and STBY) are controlled by the emulator. These signals can be masked by the HEW. In default, the STBY signal is masked. The RES signal is valid only when emulator enters run mode.

4.6 Watch Dog Timer (WDT)

The WDT operates during run mode emulation, and does not operate when the emulator is in the break mode. The timer is disabled at a break and enabled when emulation resumes.

4.7 16-bit Timer Pulse Unit (TPU) and 8-bit Timer

The TPU and the 8-bit timer operate during the break mode as well as the user mode i.e., the timer pins are valid even when the user program has stopped. The user can rewrite the timer registers with the *I/O* window or *Memory* window.

4.8 Serial Communications Interface (SCI)

The serial communications interface signals are connected to the user system directly from the H8S MCU in the emulator. Therefore, the interface is valid both in the break and run mode. For example, when writing data to the TDR (transmit data register) in the *I/O* or *Memory* Window, after the serial communications interface output has been initialized, data is output to the TXD line.

4.9 Programmable Pulse Generator (PPG)

The PPG operates during break and run modes.

4.10 DMA Controller (DMAC)

The DMAC operates during emulation execution and in the break mode. When a transfer request occurs, the emulator carries out DMA transfer.

4.11 Data Transfer Controller (DTC)

The DTC operates during emulation execution and in the break mode. When a transfer request occurs, the emulator carries out DTC transfer. The DTC RAM data is not accessible during run mode i.e., no POTF is possible for DTC RAM.

NOTE: The DTC is connected to the area from address H'FF-EBC0 to H'FF-EFBF in the internal RAM through a 32 bit bus. Therefore for transfer between the high order 16 bits of the DTC and the internal RAM, trace information cannot be acquired and no break can be generated.

4.12 Bus State Controller

The H8S bus state controller has a programmable wait mode and a WAIT pin input mode. The programmable wait mode is valid when the emulation memory or user (target or external) memory is accessed, but input to the WAIT pin is only valid when the user memory is accessed. Input to the user WAIT pin is always valid during refresh cycles.

4.13 I/O Ports

The H8S I/O ports can be used as peripheral module I/O pins or as an address/data bus, depending on the operation mode or internal register settings. The I/O port pins are valid during execution & break state. User can access or modify the I/O port pins (multiplexed with peripheral module I/O pins) with the I/O and MEMORY window.

4.14 A/D Converter

The analogue I/O pins are connected to the user system directly from the H8S MCU. Thus the reading are valid during the execution and break state. Connect the AVCC pin (the VCC pin for the A/D) and the VREF (reference voltage pin) to the A/D and D/A conversion power supply and the reference power supply on the user's system.

NOTE: AVCC and VREF pins must be connected to VCC pins when the A/D and D/A converters are not used. The conversion precision on the emulator is lower than that of the actual MCU. This is mainly due to the extra resistance and capacitance introduced in the cabling and printed circuit boards.

Section 5. Differences between H8S Microcomputer and Emulator

5.1 Power up and reset

When the emulator initialises the system or resets the Microcomputer as a result of a command such as switching the clock, or when the reset command is used, note that the general-purpose registers and part of the control registers are initialized.

Table 5-1 Differences between H8S and Emulator

Status	Register	Emulator	H8S
Emulator Initialisation (power on)	PC	Power on reset vector value	Power on reset vector value
	ER0 to ER6	H'00000000	Undefined
	ER7 (SP)	H'FFEFBC	Undefined
	CCR	The I mask is set to 1 and the other bits are undefined (B'1-----)	The I mask is set to 1 and the other bits are undefined (B'1-----)
	EXR	Trace bit is set to 0 and the interrupt bits are set to 1 (B'0----111)	Trace bit is set to 0 and the interrupt bits are set to 1 (B'0----111)
Emulator Initialisation (reset command)	PC	Power on reset vector value	Power on reset vector value
	ER0 to ER6	Undefined	Undefined
	ER7 (SP)	Undefined	Undefined
	CCR	The I mask is set to 1 and the other bits are undefined (B'1-----)	The I mask is set to 1 and the other bits are undefined (B'1-----)
	EXR	Trace bit is set to 0 and the interrupt bits are set to 1 (B'0----111)	Trace bit is set to 0 and the interrupt bits are set to 1 (B'0----111)

5.2 User Interface

User may have to adjust the target system as follows:

- The emulator's user system interface is provided with pull-up resistors and/or a buffer, causing the signals to be delayed slightly.
- The pull-up resistors will change high-impedance signals to high level signals.
- The Analog to Digital conversion's resolution will have a slight degradation.
- Load capacitance of the emulator as compared to the actual chip will be larger.
- Crystal oscillator can only be used if the actual footprint user cable is used (there is an oscillating circuitry built on-board). If user uses the direct method of connecting to the target system, the actual clock signal has to be connected to the EXTAL pin (**NOTE:** there is no XTAL pin).
- If user uses the direct connection method, the signal (CABLE_IN_N) has to be connected to ground.

Please refer to section 6 for the details of user interface circuitry

Section 6. User System Interface

The user target system is connected to the emulator via the interface cable. Interface circuitry is inserted in between to remove noise and protect the emulator. When connecting the user target system to the emulator, user has to consider the adjustment of the user system hardware. Compensation for FAN-IN, FAN-OUT and propagation delays are necessary. In general, the one-way propagation delay of the cabling is about 4ns. However, the user clock signal is delayed for approximately 25 ns.

All signals are connected to the MCU with no buffering with the exception of

- NMI
- RESET
- STBY
- MD[2..0]
- EXTAL

The emulator does not detect the following signals

- FWE
- OSC1
- OSC2
- CVCC
- XTAL

All port signals are pulled up by a 47K ohm resistor with the exception of all analogue pins (Ports 4 and 9).

All signals satisfy the MCU AC timing specification.

The illustration of the user interface circuitry will be as follows.

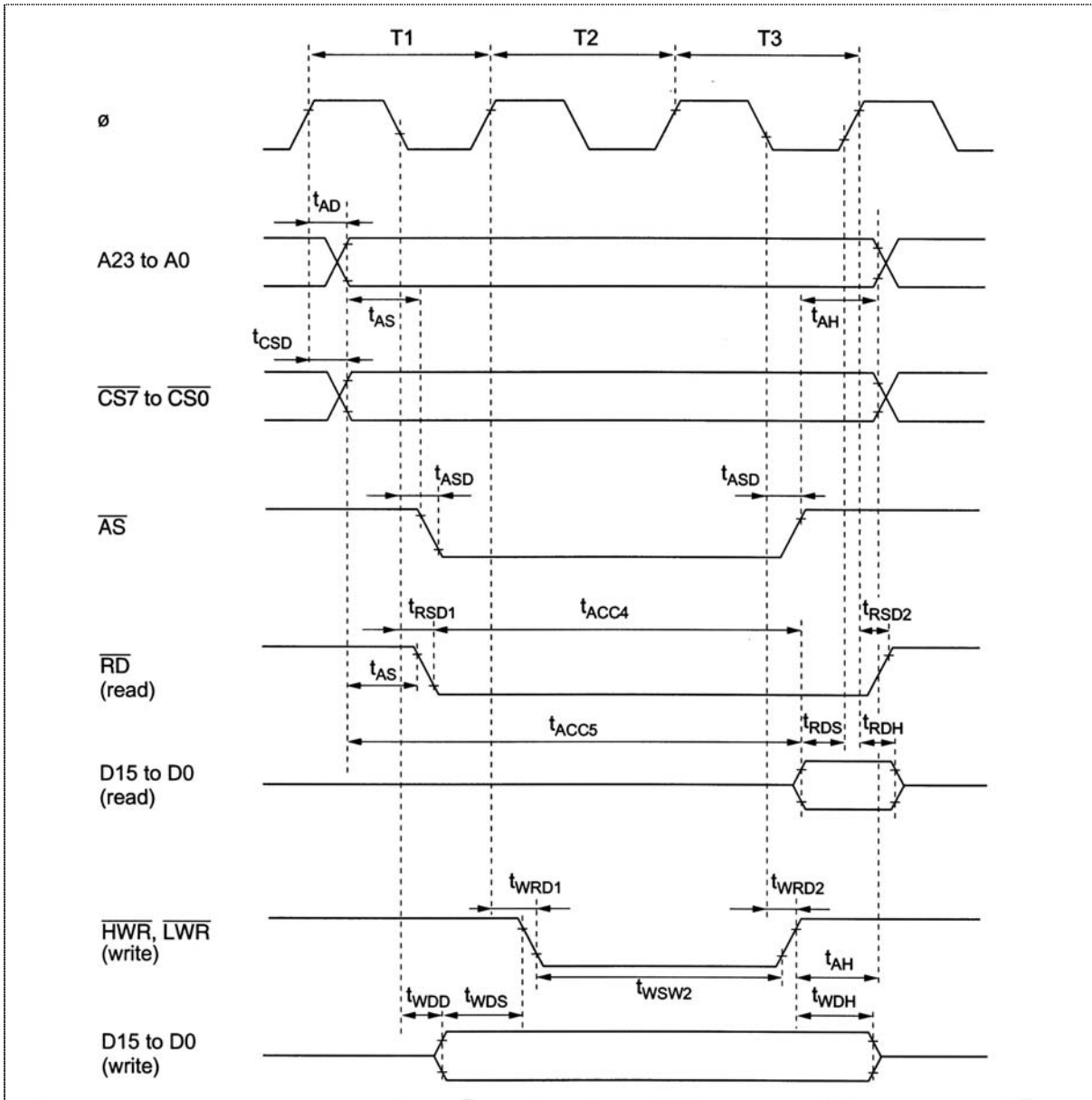

Figure 6-1 Basic Bus Cycle Timing in Expanded mode

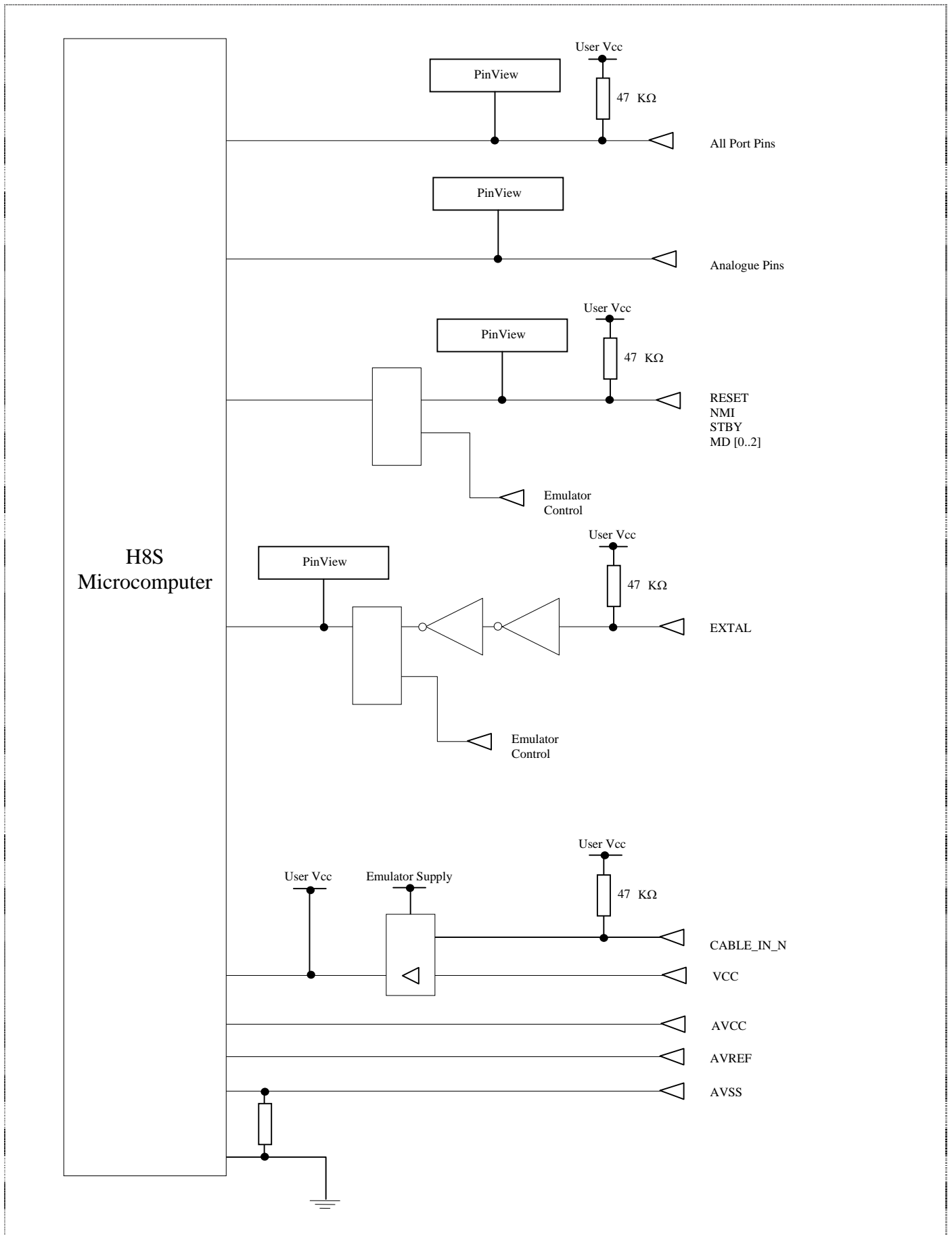

Figure 6-2 Interfacing Circuitry

- Blank Page -

Section 7. Tutorial

The following describes a sample debugging session, designed to introduce the main features of the CE2000-H8S/2238 emulator used in conjunction with the High-performance Embedded Workshop(HEW) software.

The tutorial is designed to run in the CE2000-H8S/2238 emulator's resident memory so that it can be used without connecting the CE2000-H8S/2238 emulator to any external user system.

7.1 Introduction

The tutorial is written in C source code.

Before reading this chapter:

- Setup the CE2000-H8S/2238 emulator and verify that it is working correctly with the HEW software. The CE2000-H8S/2238 emulator need not be connected to any user system when using this tutorial.
- User has to be familiar with the architecture and instruction set of the H8S/2238 Series MCU. For more information please refer to the H8S/2238 Series Programming Manual and H8S/2238 Series Hardware Manual.

7.2 Overview

This program is an infinite loop that sort elements based on NAME in the alphabetical order, and AGE and ID in the numeral ascending order.

The tutorial is provided on the installation disk as the file 2238.c. A compiled version of the tutorial is provided in Motorola S-Record in the file 2238.mot.

7.3 How the Tutorial Program Works

The first part of the program includes a series of header files:

```
#include "machine.h"
#include "string.h"
```

The program then gives prototypes for the constants, structures, and function initial values:

```
#define NAME (short)0
#define AGE (short)1
#define ID (short)2
#define LENGTH 8

struct namelist {
    char name[LENGTH];
    short age;
    long idcode;
};

struct namelist section1[] = {
    "Naoko", 17, 1234,
    "Midori", 22, 8888,
    "Rie", 19, 7777,
    "Eri", 20, 9999,
    "Kyoko", 26, 3333,
    "", 0, 0
};

int count;

void sort();
```

Now the main program.

```
main()
{
    count = 0;
    for ( ; ; ){
        sort(section1, NAME);
        count++;
        sort(section1, AGE);
        count++;
        sort(section1, ID);
        count++;
    }
}
```

The remainder of the program defines the functions called from main:

```

void sort(list, key)
struct namelist list[];
short key;
{
    short i,j,k;
    long min;
    char *name;
    struct namelist worklist;

    switch(key){
        case NAME :
            for (i = 0 ; *list[i].name != 0 ; i++){
                name = list[i].name;
                k = i;
                for (j = i+1 ; *list[j].name != 0 ; j++){
                    if (strcmp(list[j].name , name) < 0){
                        name = list[j].name;
                        k = j;
                    }
                }
                worklist = list[i];
                list[i] = list[k];
                list[k] = worklist;
            }
            break;

        case AGE :
            for (i = 0 ; list[i].age != 0 ; i++){
                min = list[i].age;
                k = i;
                for (j = i+1 ; list[j].age != 0 ; j++){
                    if (list[j].age < min){
                        min = list[j].age;
                        k = j;
                    }
                }
                worklist = list[i];
                list[i] = list[k];
                list[k] = worklist;
            }
            break;

        case ID :
            for (i = 0 ; list[i].idcode != 0 ; i++){
                min = list[i].idcode;
                k = i;
                for (j = i+1 ; list[j].idcode != 0 ; j++){
                    if (list[j].idcode < min){
                        min = list[j].idcode;
                        k = j;
                    }
                }
                worklist = list[i];
                list[i] = list[k];
                list[k] = worklist;
            }
            break;
    }
}

```

7.4 Running HEW

Execute HEW from start up menu.

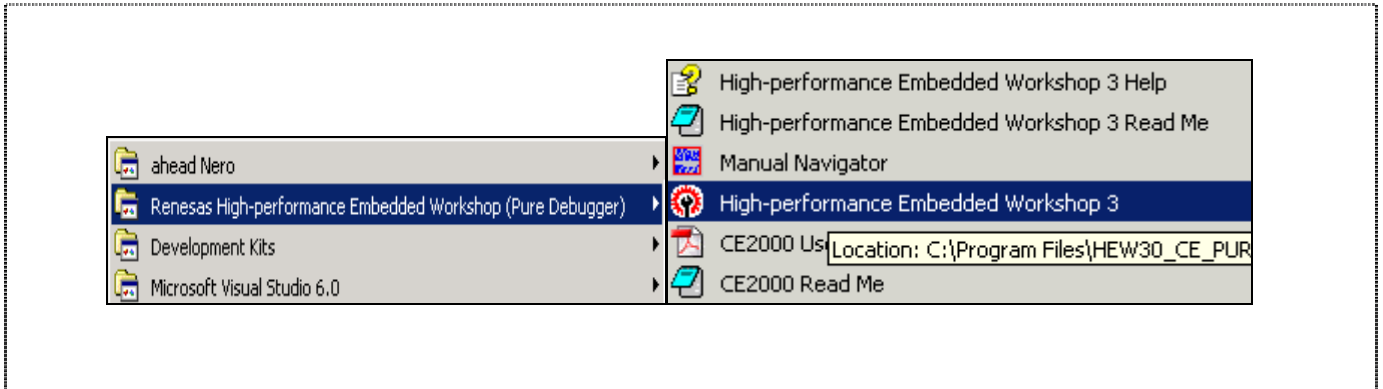

Figure 7-1 Execute HEW from Start Menu

7.4.1 Opening Tutorial workspace

Open the “Tutorial” workspace for CE2000 target by clicking menu *File->Open workspace...* in the installed directory.

Note: On a first time loading of the tutorial, a dialog box prompting the move of workspace from previous installed directory is displayed. Please click [YES] and the workspace would be configured to the current installed directory permanently.

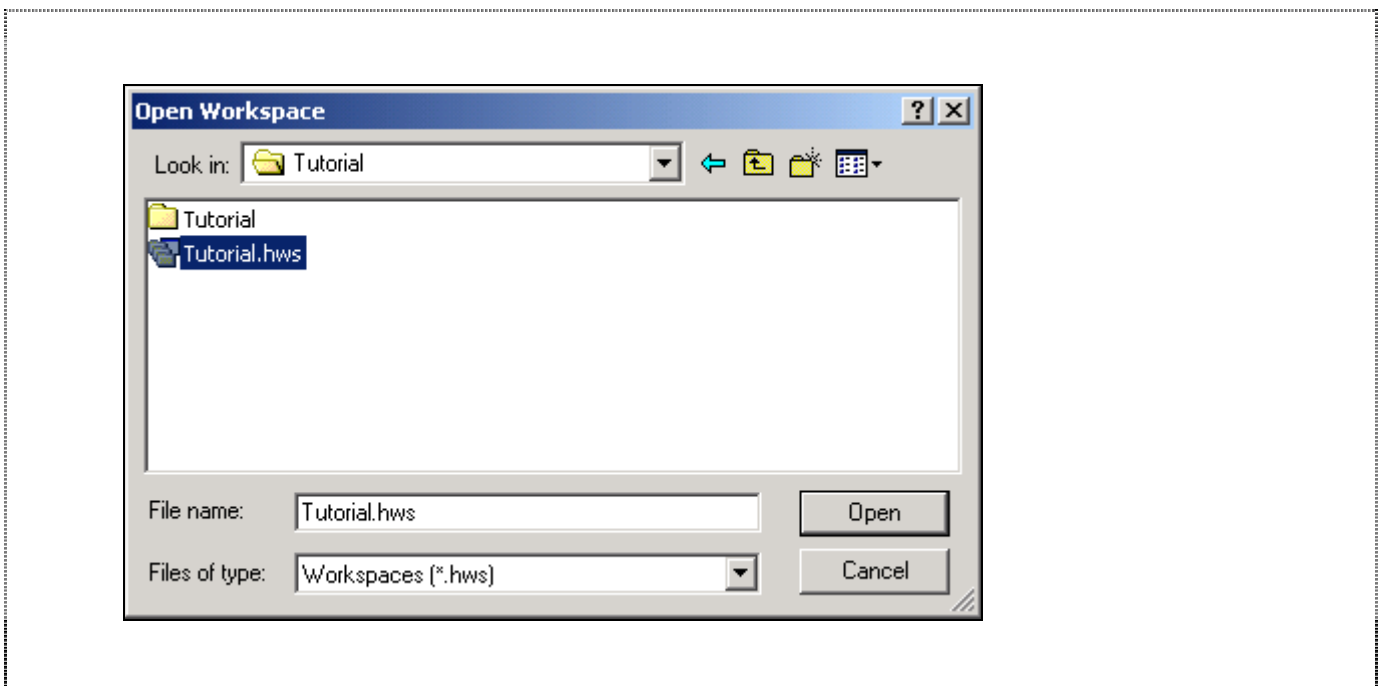

Figure 7-2 Open Tutorial workspace

7.5 Setting up the HEW(Pure Debugger) for CE2000-H8S/2238

Before downloading a program to the CE2000-H8S/2238 emulator, the following items need to be configured:

- device type
- memory map

The following sections describe how to setup the CE2000-H8S/2238 emulator for running the tutorial program.

7.5.1 Configuring the Platform

To setup the target configuration:

- Choose menu *Options->Emulator->System...* to open *Configure Platform* dialog.

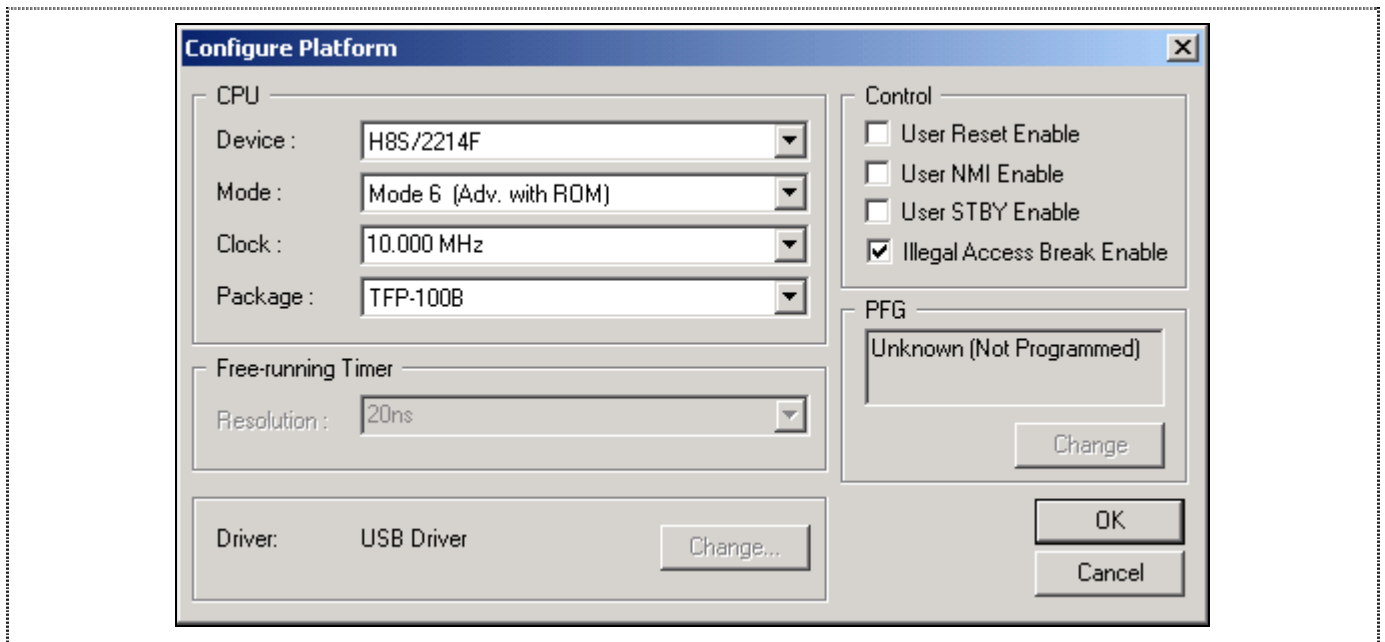

Figure 7-3 Configure Platform dialog

7.5.2 Mapping the Memory

The next step is to map the emulation memory of CE2000-H8S/2238 emulator for the application you are developing.

- To display the current memory mapping, choose *Options->Emulator->Memory Resource...* menus.

The *Memory Mapping* dialog... shown in the following figure:.

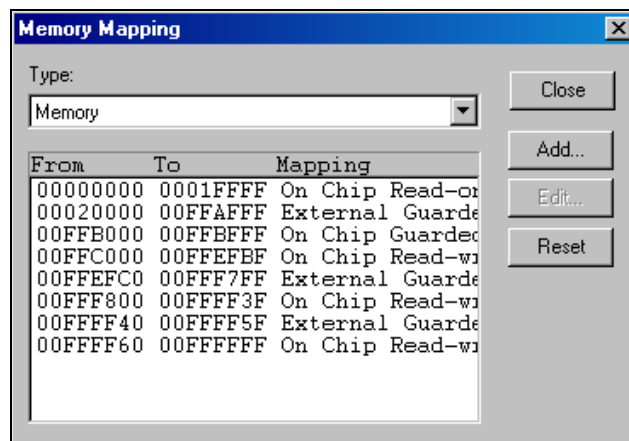

Figure 7-4 Memory Mapping Dialog

Click on the Close button to end the Memory Mapping configuration and open Status window under the View menu. Select the Memory tab in Status window to show the Memory Mapping configured:

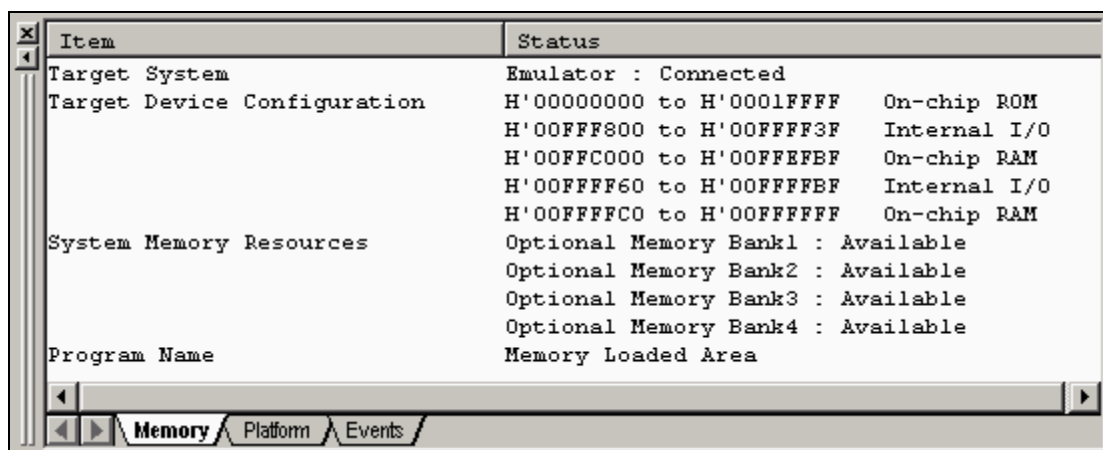

Figure 7-5 Memory page of Status window

- Target Device Configuration : Display the memory configuration of the specific target device selected.
- System memory resources : Display the optional memory resource available to user during their emulation process
- Loaded Memory Areas : Display the memory space that the loaded program has occupied

The CE2000-H8S/2238 emulator allows you to configure the attribution of the mapped memory. Please refer to Section 3 for more details of memory mapping.

For this tutorial, user will be using the default mapping displayed. To view the mapping, double-click the appropriate range in the Memory Mapping window.

The Edit Memory Mapping dialogue box is displayed. An example is shown in the figure below.

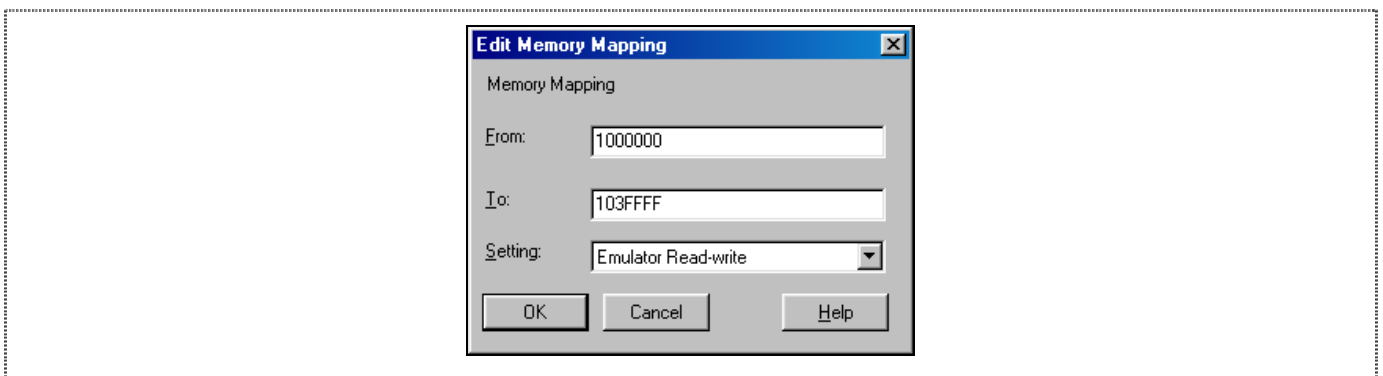

Figure 7-6 Edit Memory Mapping Dialog

- Click OK to close the dialog-box.

7.6 Downloading the Tutorial Program

Once the CE2000-H8S/2238 emulator has been setup, user can download the object program for debugging.

7.6.1 Loading the Download Module

- Specify the download module by selecting *Options->Debug Settings...* to open *Debug Settings* dialog as below.

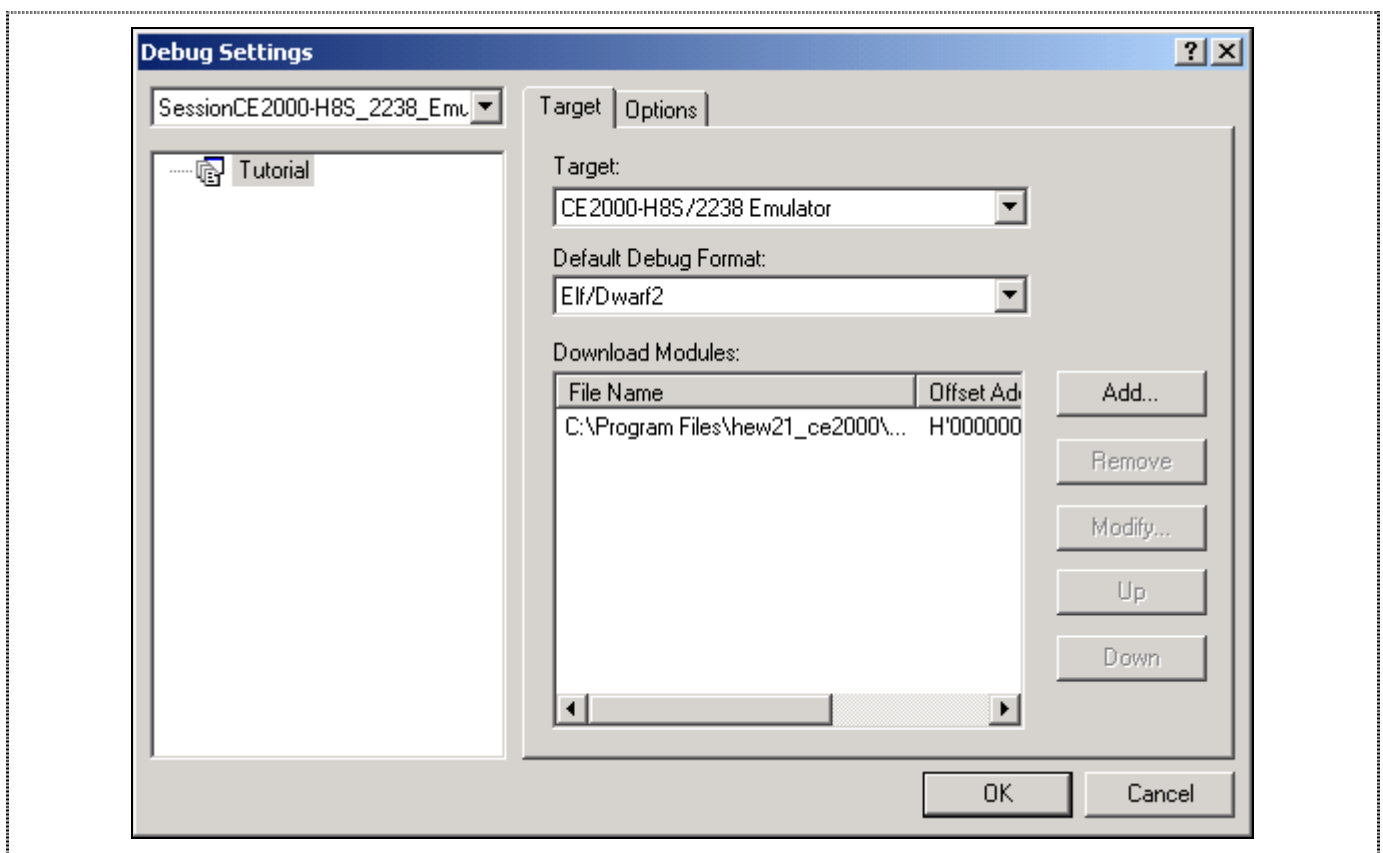

Figure 7-7 Debug Settings Dialog

- Click *Add* button to specify the download module.
- Click *Debug->Download modules* menu to download the specified module.

7.6.2 Displaying the Program Listing

HEW allows user to debug a program at C-Source and Assembly level.

Choose *Reset CPU* from the *Debug* menu, "resetprg.c" file will be opened as below:

<pre> 0x00000400 0x00000406 0x00000408 </pre>	<pre> //#endif #pragma section ResetPRG _entry(vect=0) void PowerON_Reset(void) { set_imask_ccr(1); _INITSCT(); // _CALL_INIT(); // Remove the cc // _INIT_IOLIB(); // Remove the cc // errno=0; // Remove the cc </pre>
---	---

Figure 7-8 resetprg.c file after RESET CPU

7.7 Using Breakpoints

The simplest debugging aid is the program breakpoint, it causes execution to stop when a particular point in the program is reached. You can then examine the state of the MCU and memory at that point in the program.

7.7.1 Setting a Program Count (PC) Breakpoint

The program window provides a very simple way of setting a program breakpoint. For example, set a breakpoint at address H'80C as follows:

- Right-click in the 2238.c file and select *Toggle Breakpoint* popup menu at the line containing address H'80C.

<pre> 0x00000800 0x0000080c 0x00000838 0x00000810 0x00000816 0x0000081c 0x00000824 0x0000082a 0x00000832 </pre>	<pre> void sort(); main() { count = 0; for (; ;){ sort(section1, NAME); count++; sort(section1, AGE); count++; sort(section1, ID); count++; } } </pre>
---	--

Figure 7-9 Setting a Breakpoint

The dot will be displayed there to indicate that a program breakpoint is set at that address.

7.7.2 Executing the Program

To run the program from reset:

- Choose *Reset Go* from the *Debug* menu

The program is executed up to the breakpoint you inserted, and the statement will be highlighted in the program window to show that the program has halted.

```

int count;

void sort();

main( )
{
0x00000800  count = 0;
0x0000080c  for ( ; ; ){
0x00000838      sort(section1, NAME);
0x00000810      count++;
0x00000816      sort(section1, AGE);
0x0000081c      count++;
0x00000824      sort(section1, ID);
0x0000082a      count++;
0x00000832

```

Figure 7-10 Program Break

The message Break = PC Break is displayed in the status window to show the cause of the break.

This can be viewed under *Last Break Cause* in the Status window.

- Choose Status Window from the View menu, or click the Status Window button in the toolbar:

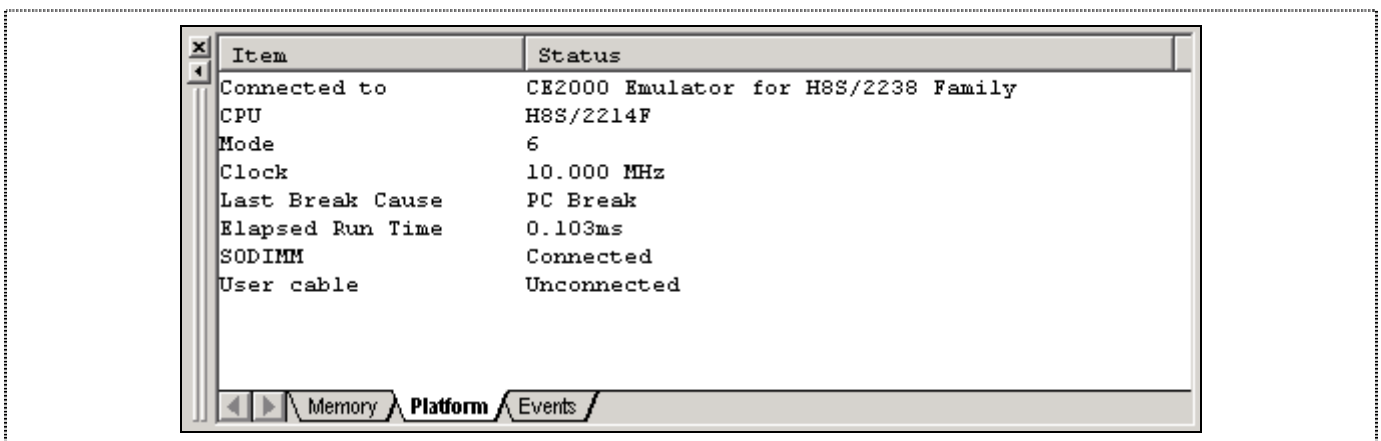

Figure 7-11 Platform page of Status Window

The cause of last break line shows that the break was a PC Break.

7.7.3 Reviewing the Breakpoints

The list of all the breakpoints set in the program can be viewed in the Eventpoints window.

- Choose Eventpoints from the View menu, or click the Eventpoints Window button in the toolbar:

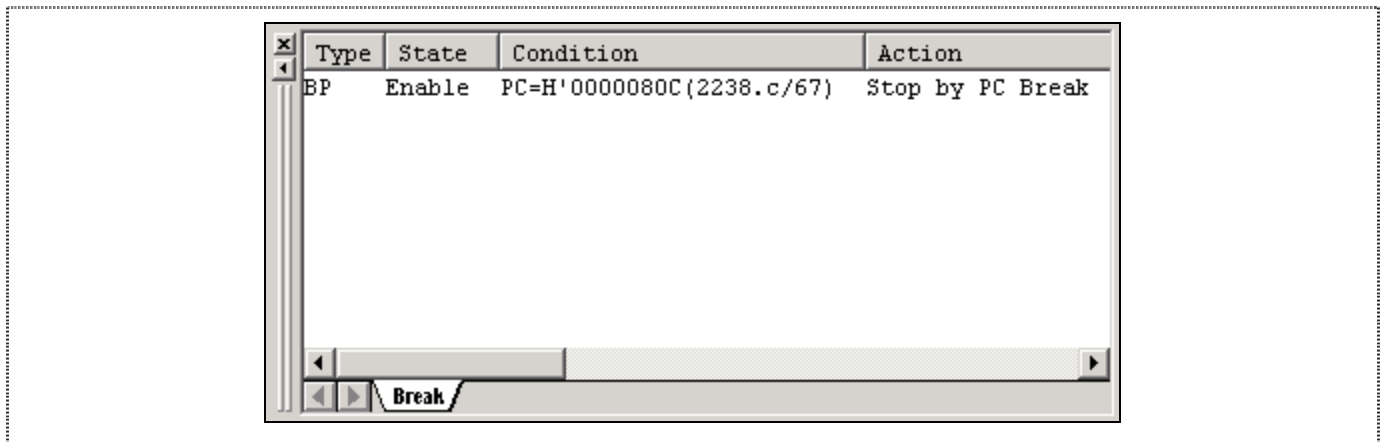

Figure 7-12 Eventpoints Window

The Eventpoints window also allows user to perform the following:

- Define new breakpoints
- Delete existing breakpoints
- Disable existing breakpoints

Do a right-mouse click within the Eventpoints -window to show the following pop-up:

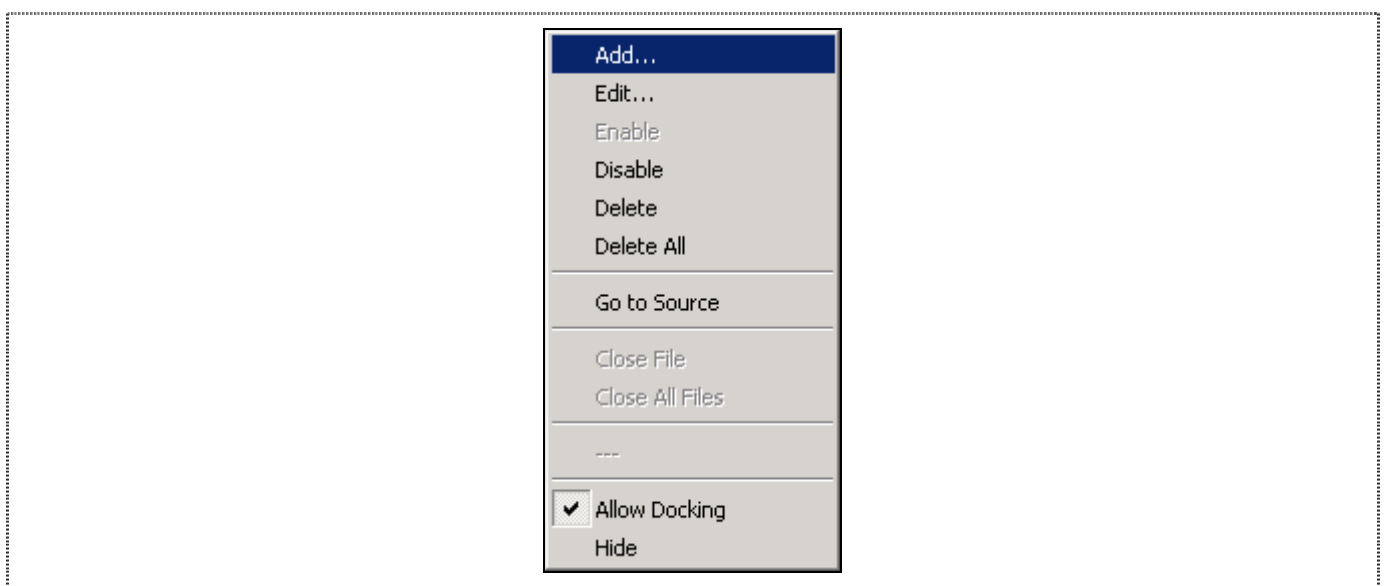

Figure 7-13 Popup menus in Eventpoints Window

7.7.4 Examining MCU Registers

While the program is halted, you can examine the contents of the H8S/2238 Series MCU registers. These are displayed in the Registers Window.

- Choose Registers from the View menu, or click the Registers Window button in the toolbar:

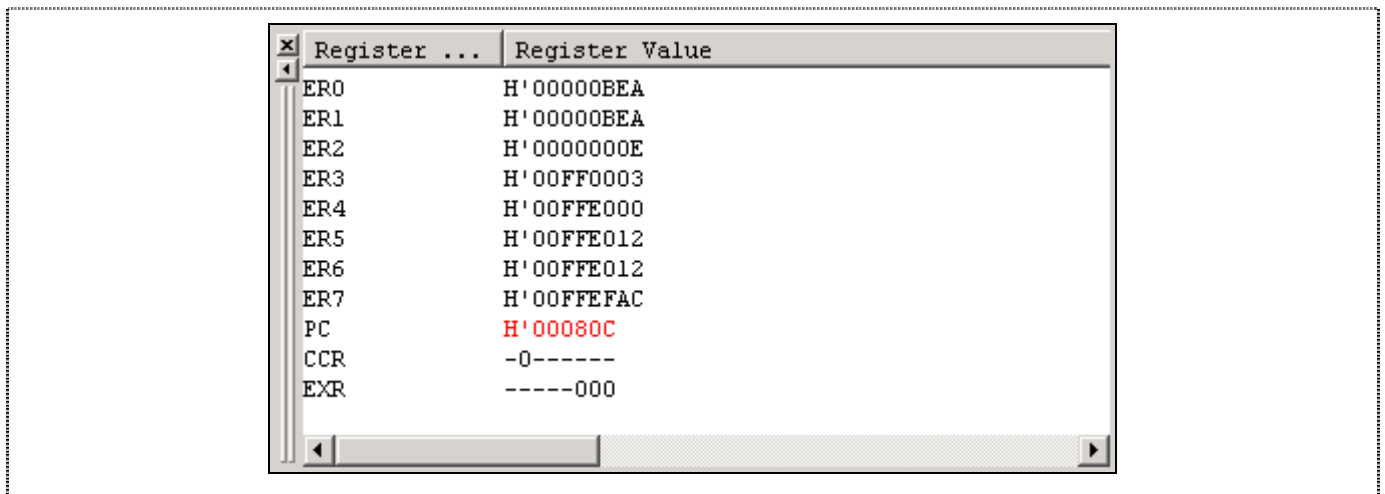

Figure 7-14 CPU Registers Window

As expected, the value of the program counter (PC) is the same as the highlighted statement, H'80C.

The registers' values can be changed from the Registers window. For example, change the value of the PC:

- Double-click on PC in the Registers window

The Register-PC dialog allows you to edit the value.

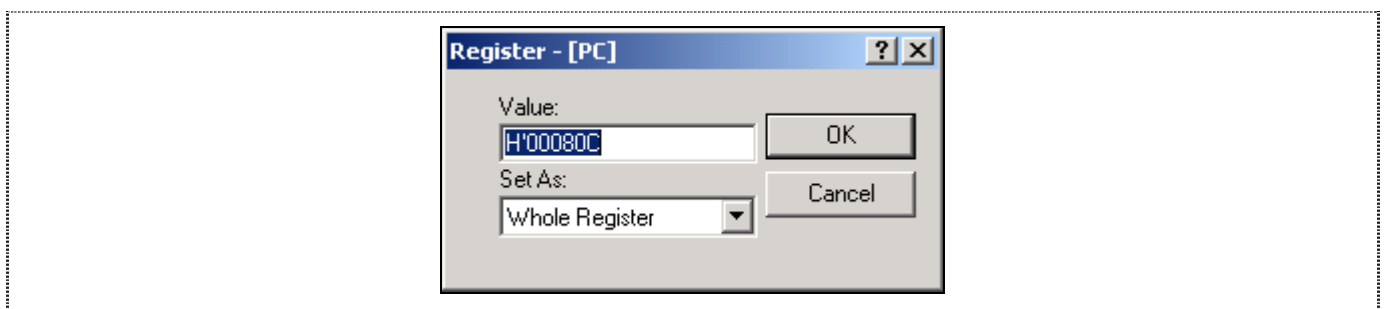

Figure 7-15 Changing Register Value

7.8 Examining Memory and Variables

The behavior of a program can be monitored by examining the contents of an area of memory, or by displaying the values of variables used in the program.

7.8.1 Viewing Memory

The contents of a block of memory can be viewed in the Memory Window.

For example, to view memory:

- Choose Memory... from the View menu, or click the Memory Window button in the toolbar.



- Enter values as below:

The image shows a 'Format' dialog box with the following fields and values:

- Begin: H'00000000
- End: H'000000FF
- Format: Byte (x1)
- Display Value As: ANSI character
- Bytes Count For One Line: 16 Byte

Figure 7-16 Open Memory Window

- Click OK to open the Memory window showing the specified memory area.

Address	+0	+1	+2	+3	+4	+5	+6	+7	+8	+9	+A	+B	+C	+D	+E	+F	Value
0x00000000	00	00	04	00	A8	3A	6A	90	2D	6F	90	62	C1	8A	A4	E2j.-o.b....
0x00000010	BC	C5	37	40	00	00	04	1A	00	00	04	1C	00	00	04	1E	..7@.....
0x00000020	00	00	04	20	00	00	04	22	00	00	04	24	00	00	04	26"....\$....
0x00000030	30	2E	0C	0A	08	86	EA	D0	6A	1C	56	2B	08	B4	71	5C	0.....j.V+..q\
0x00000040	00	00	04	28	00	00	04	2A	00	00	04	2C	00	00	04	2E	...{...*.....
0x00000050	00	00	04	30	00	00	04	32	00	00	04	34	00	00	04	36	...0...2...4...6
0x00000060	00	00	04	38	00	00	04	3A	60	90	60	34	00	00	04	3C	...8...:\`4...<
0x00000070	00	00	04	3E	00	00	04	40	94	7C	9B	27	64	26	78	DA	...>...@.l.'dx.
0x00000080	00	00	04	42	00	00	04	44	00	00	04	46	00	00	04	48	...B...D...F...H
0x00000090	00	00	04	4A	51	25	14	3B	23	EF	04	20	03	A0	AC	50	...JQ%.;#.....P
0x000000A0	00	00	04	4C	00	00	04	4E	00	00	04	50	00	00	04	52	...L...N...P...R
0x000000B0	00	00	04	54	00	00	04	56	00	00	04	58	00	00	04	5A	...T...V...X...Z

Figure 7-17 Memory Window

7.8.2 Watching Variables

It is useful to be able to watch the values of variables as the program is being stepped.

For example, set a watch on the struct variable `section1`, which is declared at the beginning of the program, using the following procedure:

- Scroll up in the program window until you see the line:
`sort(section1, ID);`
- In the Program windows click once at the word `section1` to position the blinking cursor on the word `section1`.
- Within the Program Window (Tutorial.c) perform a right mouse button click to display a pop-up menu, and choose *Instant Watch...*

The Instant Watch dialog will be displayed:

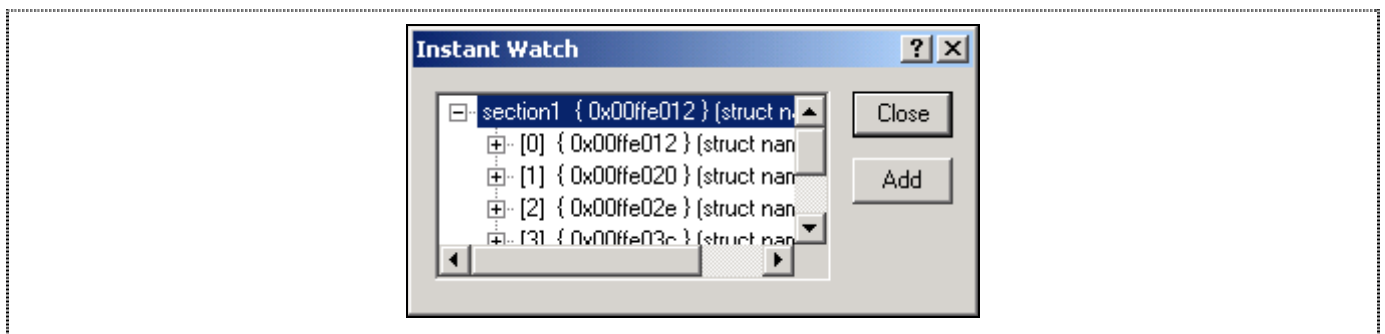

Figure 7-18 Instant Watch dialog

- Click *Add* button to add the variable to the Watch Window.

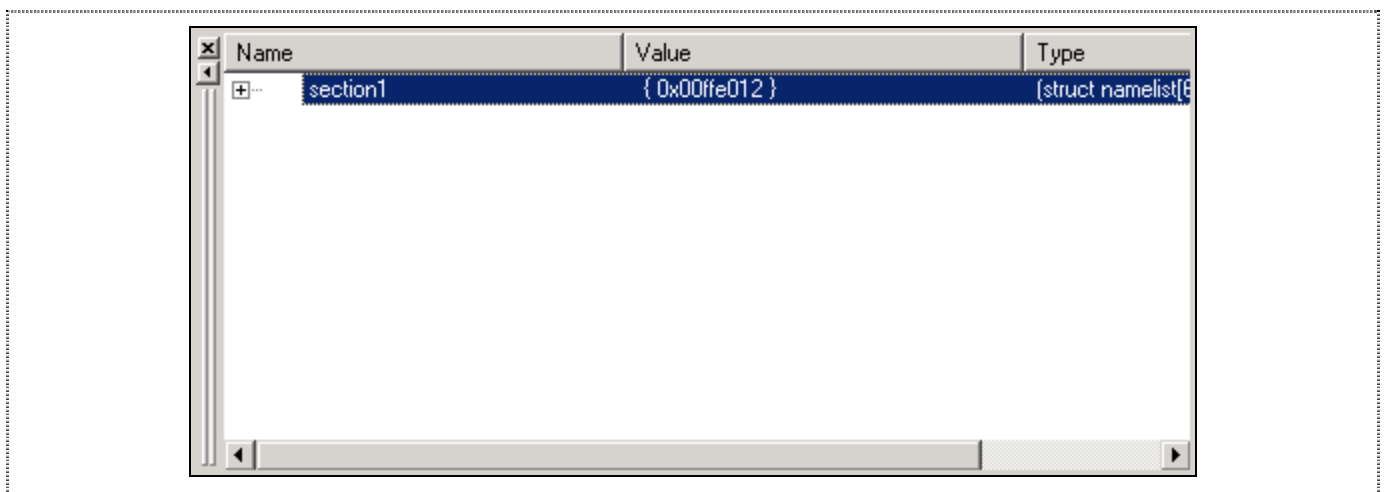

Figure 7-19 Watch Window

A variable watch can be added to the Watch Window by specifying its name. Use this method to add a Watch on the variable `count` as follows:

- Click with the right mouse button within the Watch window and choose *Add Watch...* from the pop-up menu.

The *Add Watch* dialog appears.

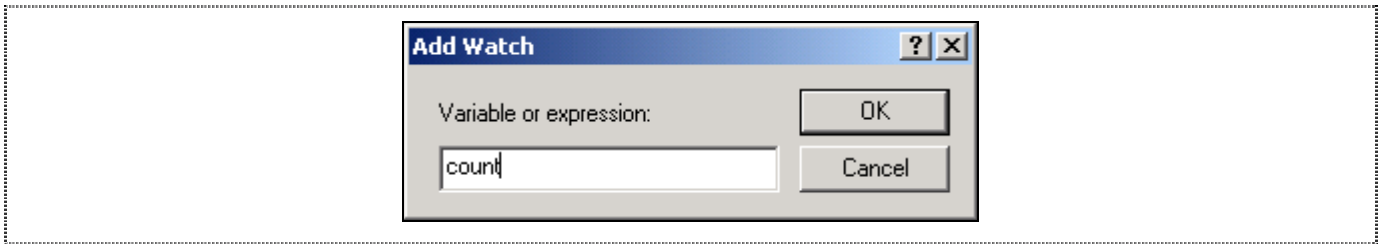

Figure 7-20 Add Watch Dialog

- Type the variable *count* and click OK.

The Watch Window will show the content of the variable label *count* (note that you might be getting different result of *count*).

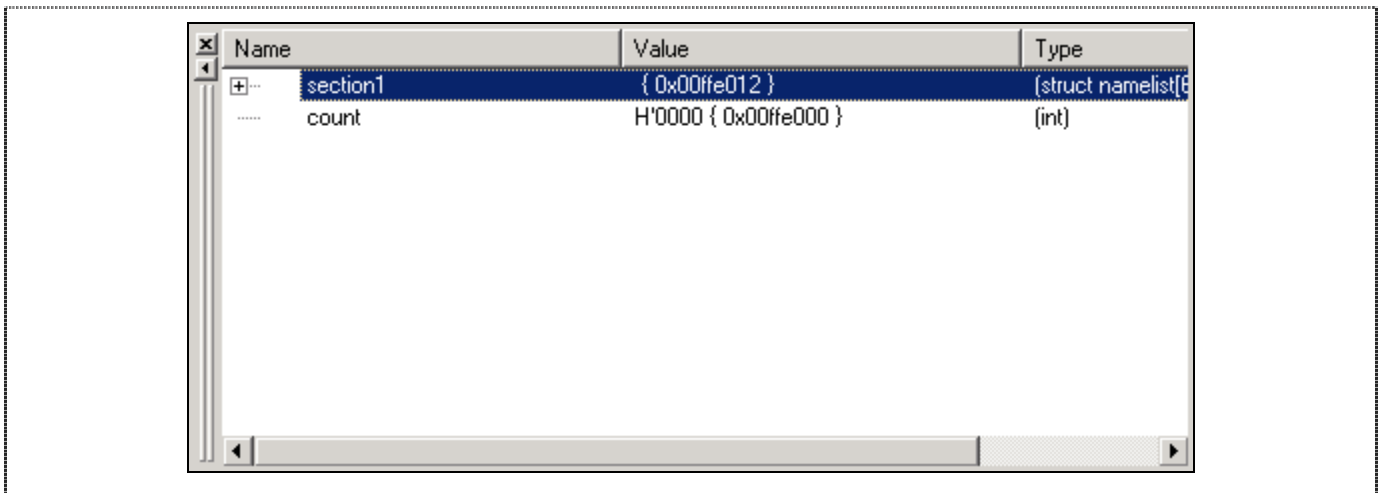

Figure 7-21 Watch Window

You can click on the + symbol to the left of any symbol in the Watch window to expand it and display the individual elements in the array.

Name	Value	Type
section1	{ 0x00ffe012 }	(struct namelist[6])
[0]	{ 0x00ffe012 }	(struct namelist)
idcode	H'000004d2 { 0x00ffe01c }	(long)
age	H'0011 { 0x00ffe01a }	(short)
name	"Naoko" { 0x00ffe012 }	(char[8])
[1]	{ 0x00ffe020 }	(struct namelist)
idcode	H'000022b8 { 0x00ffe02a }	(long)
age	H'0016 { 0x00ffe028 }	(short)
name	"Midori" { 0x00ffe020 }	(char[8])
[2]	{ 0x00ffe02e }	(struct namelist)
[3]	{ 0x00ffe03c }	(struct namelist)
[4]	{ 0x00ffe04a }	(struct namelist)

Figure 7-22 Displaying Individual Elements in an Array

7.9 Stepping Through a Program

The CE2000-H8S/2238 emulator provides a range of options for stepping through a program, executing an instruction or statement at a time.

7.9.1 Stepping

- **Step In(F11)**
 - Set PC = H'80C.
 - Execute *Step In* 2 times.

0x0000081c	sort(section1, AGE);
0x00000824	count++;
0x0000082a	sort(section1, ID);
0x00000832	count++;
	}
	}
0x0000083a	void sort(list, key)
	struct namelist list[];
	short key;
0x00000846	{
	short i, j, k;
	long min;
	char *name;
	struct namelist worklist;

Figure 7-23 Step In

The program is now stop at address H'83A and step into function *void sort(list, key)*.

- **Step Over(F10)**
 - Set PC = H'80C.
 - Execute *Step Over* 2 times.

	<code>void sort();</code>
	<code>main()</code>
<code>0x00000800</code>	<code>{</code>
<code>0x0000080c</code>	<code>count = 0;</code>
<code>0x00000838</code>	<code>for (; ;){</code>
<code>0x00000810</code>	<code>sort(section1, NAME);</code>
<code>0x00000816</code>	<code>count++;</code>
<code>0x0000081c</code>	<code>sort(section1, AGE);</code>
<code>0x00000824</code>	<code>count++;</code>
<code>0x0000082a</code>	<code>sort(section1, ID);</code>
<code>0x00000832</code>	<code>count++;</code>
	<code>}</code>
	<code>}</code>

Figure 7-24 Step Over

The program is now stop at address H'816 and step over function *void sort(list, key)*.

7.10 Using the PFG Breakpoint

The PFG Breakpoint allows user to halt the program based on several conditions matching at the same time (such as address, data, ...).

7.10.1 Defining a PFG Breakpoint

Now define a PFG Breakpoint to monitor this part as follows:

- Choose Eventpoints_from the View menu to display the Eventpoints Window, or click the Eventpoints Window button in the toolbar.



- Click Add to define a new breakpoint.

The *Breakpoint Setting* dialog allows you to define the properties of individual breakpoint.

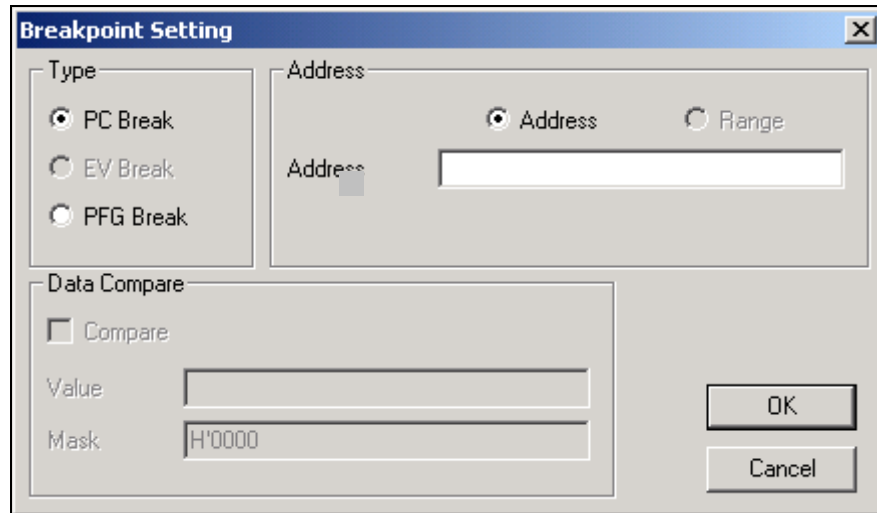

Figure 7-25 Breakpoint Setting Dialog

- Select radio button *PFG Break*
- A message box will be displayed to allow user to program this PFG function before it can be used as shown in Figure 7-26. Click *Yes* button.

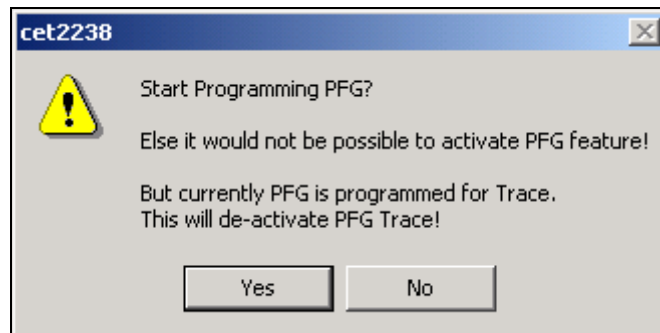

Figure 7-26 PFG Programming

- Enter H'82A in the *Address Lo* edit box. Click *OK* button.

The **Eventpoints** window shows the new Breakpoint you have defined.

Type	State	Condition	Action
BP	Enable	PC=H'0000080C(2238.c/67)	Stop by PC Break
BPFPG	Enable	Address=H'0000082A	Stop by PFG Break Channel-1

Figure 7-27 Eventpoints Window

- Run the program from the current position, by choosing *Go* from the *Debug* menu, or click the *Go* button in the toolbar.



Execution will stop as below:

0x00000800	{
0x0000080c	count = 0;
0x00000838	for (; ;){
0x00000810	sort(section1, NAME);
0x00000816	count++;
0x0000081c	sort(section1, AGE);
0x00000824	count++;
0x0000082a	sort(section1, ID);
0x00000832	count++;
	}
0x0000083a	}
0x0000083a	void sort(list, key)
	struct namelist list[];
	short key;

Figure 7-28 PFG Break

- The system status window will display *Last Break Cause = PFG Break* to indicate the type of break that has occurred.

7.11 Watching Local Variables

The localised variables within a function can be viewed using the Local Variables Window. For example, in order to examine the local variables in the function sort.

- Open the Local window by choosing Local... from the View menu.

Note: The Local Window will be empty if there is no local variable declared or local variables have not yet been entered. In another words, user target program execution should halt within a function with local variables to show any variables within Locals Window. In this tutorial, once when the execution halts within the function sort(), the local variables within function sort() will be shown in Locals Window:

Name	Value	Type
list	0x00ffe012 { ER6 }	(struct namelist*)
key	H'004e { R1 }	(short)
i	H'0000 { R4 }	(short)
j	Not available now.	
k	H'0000 { R3 }	(short)
min	Not available now.	
name	0x00ffe012 { 0x00fef90 }	(char*)
worklist	{ 0x00fef7e }	(struct namelist)

Figure 7-29 Locals Window

- Click on the + symbol in front of the variable worklist in the Locals window to display the individual elements of the array worklist.

Name	Value	Type
list	0x00ffe012 { ER6 }	(struct namelist*)
x	{ 0x00ffe012 }	(struct namelist)
idcode	H'000004d2 { 0x00ffe01c }	(long)
age	H'0011 { 0x00ffe01a }	(short)
name	"Naoko" { 0x00ffe012 }	(char[8])
key	H'004e { R1 }	(short)
i	H'0000 { R4 }	(short)
j	Not available now.	
k	H'0000 { R3 }	(short)
min	Not available now.	
name	0x00ffe012 { 0x00fef90 }	(char*)
x	"Naoko" { 0x00ffe012 }	(char)
worklist	{ 0x00fef7e }	(struct namelist)

Figure 7-30 Displaying Individual Elements in an Array

7.12 Using the Trace Buffer

The trace buffer allows us to look back over previous H8S/2238 Series MCU operation cycles to see exactly what the H8S/2238 Series MCU has been doing prior to a specified event (break) such as an Event breakpoint.

7.12.1 Displaying the Trace Buffer

The trace buffer will display the captured bus cycle and decode the data in the trace window.

- Open the Trace Window by choosing Trace from the View menu, or click on the Trace Window button in the toolbar.



The Trace window is displayed, as shown in the following figure.

PTR	Address	Instruction	Code/Data	R/W	Status	Source	Label
-255	00000BA6	BCS @loop4:8	45f6	R	Code		
-254	00000BA8	CMP.L ER1,ER0	1f90	R	Code		next_loop3
-253	00000B9E		6c4a	R	Code		loop4
-252	00000BA0	MOV.B R2L,@ER6	68ea	R	Code		
-251	00000C2F		6800	R	Data		
-250	00000BA2	ADDS.L #1,ER6	0b06	R	Code		
-249	00FFE04F		0b00	W	Data		
-248	00000BA4	CMP.L ER5,ER4	1fd4	R	Code		next_loop4
-247	00000BA6	BCS @loop4:8	45f6	R	Code		
-246	00000BA8	CMP.L ER1,ER0	1f90	R	Code		next_loop3
-245	00000B9E		6c4a	R	Code		loop4
-244	00000BA0	MOV.B R2L,@ER6	68ea	R	Code		
-243	00000C30		00ea	R	Data		
-242	00000BA2	ADDS.L #1,ER6	0b06	R	Code		
-241	00FFE050		0006	W	Data		

Figure 7-31 Trace Window

- Adjust the width of each column by dragging the column dividers on either side of the labels just below the title bar.

7.13 Pin View

The Pin View window is displayed as shown in the following figure which has 2 types of display (Text Tree view and Graphical Chip view). It provides pin-state information of the device when it is running a program or in the idle state.

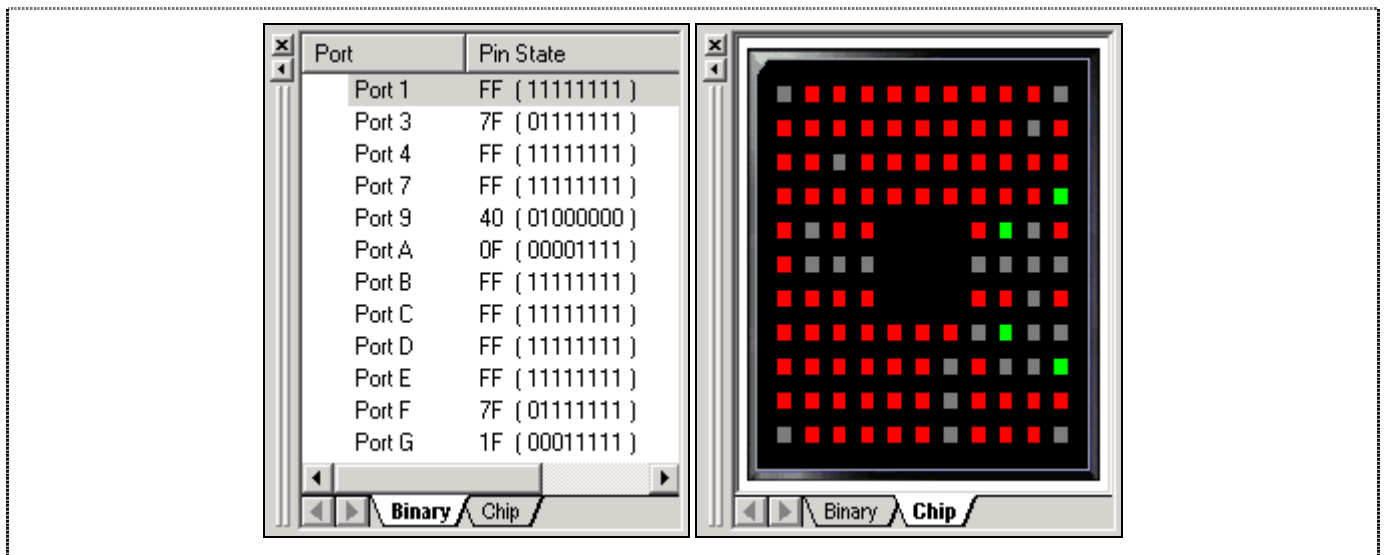

Figure 7-32 Pin View Window

7.14 Save the Session

Before exiting, it is good practice to save the session so that debugging work can be resumed instantly with the same configuration at the next debugging session.

- Choose Save Session from the File menu.
- Choose Exit from the File menu to exit from HEW.

What Next?

This tutorial has introduced the key features of the CE2000-H8S/2238 emulator, and their use in conjunction with the HEW. By combining the emulation tools provided in the CE2000-H8S/2238 emulator, user can perform extremely sophisticated debugging to track down hardware and software problems very efficiently by precisely isolating and identifying the conditions under which they occur.

Section 8. Diagnostic

The CE2000-H8S/2238 emulator is designed to have all possible protective measures, but it is still subjected to damage by user system or other unforeseen means. The CE2000-H8S/2238 emulator has a built-in test modes: Standalone Test, in which all the internal functions and pins are tested thoroughly.

8.1 Standalone Self Test

The test is implemented to allow user to have a quick check of the hardware, before linking it to the PC. This will help user to isolate the cause of the PC communication problem. The testing steps are:

- Power on the CE2000-H8S/2238 emulator (the POWER LED lights up in RED).
- Ensure the USB cable is not connected between the PC and CE2000-H8S/2238 emulator.
- Wait for 10 seconds.
- The emulator will enter Self Test mode (POWER LED changes from RED to ORANGE colour). After the tests are completed (about 2 minutes), the POWER LED will start to blink, whereas the adjacent RUN LED will light up in RED if the self test fails. However, if the self test passes, the RUN LED will not light up.

NOTE: During the self test, the RUN LED will be turned on to GREEN occasionally. This merely indicates that the emulator is in RUN mode.

Section 9. Trouble-Shooting

The following are a few suggestions on how to perform a basic troubleshooting, if the emulator does not respond to the user's commands.

Symptoms	Checks	Expected Observation & Action	
Cannot link to PC	Power Supply	POWER LED lights up in Red.	
	PC Bios setup	USB must be enabled	
	Window Device Manager	USB do not have any contention. Compact Emulator must be detected instead of a USB device.	
	Standalone Self Test		POWER LED lights up in Orange denoting entering self test mode
			Adjacent RUN LED do not light up after the test, Blinking POWER LED
	USB cable and connector contacts	Clean the contact. Change the USB cable.	
	Target System	Is user supply provided to the target?	
	HEW Setup	Has HEW been setup in the PC?	
Cannot run code on target	Clock setting	Is clock set to "target"? Is there any clock signal input to the emulator?	
	Mode setting	Is mode set to "target"?	
	Reset setting	Is reset masked in the HEW configuration platform window?	
	STBY setting	Is STBY masked in the HEW configuration platform window?	
	NMI	Is NMI masked in the HEW configuration platform window?	
	Power Supply	Is Target supplying power to the emulator?	
	Cable detection	Has HEW detected the Cable? Is CABLE_IN_N tied to ground in the target system?	
	Target connection	Is the target connection tight and secure?	
	Signal level	Is the emulator pull-up resistors driving the target system?	

- Blank Page -

Appendix A : User Connector Pin Assignment

User Connector 1 - Pin Assignment

Column	Pin	Description	Column	Pin	Description
A	40	AVSS	A	20	PE0/D0
B	40	AVCC	B	20	PE1/D1
A	39	AVCC	A	19	PE2/D2
B	39	AVSS	B	19	PE3/D3
A	38	VREF	A	18	PE4/D4
B	38	AVSS	B	18	PE5/D5
A	37	VSS	A	17	PE6/D6
B	37	WDTOVF	B	17	PE7/D7
A	36	* CABLE_IN_N	A	16	VSS
B	36	NMI	B	16	PD0/D8
A	35	STBY_N	A	15	PD1/D9
B	35	RES_N	B	15	PD2/D10
A	34	MD0	A	14	PD3/D11
B	34	MD1	B	14	PD4/D12
A	33	MD2	A	13	PD5/D13
B	33	VSS	B	13	PD6/D14
A	32	T_EXTAL_CLK/User CLK	A	12	PD7/D15
B	32	VSS	B	12	VSS
A	31	VCC	A	11	PC0/A0
B	31	VCC	B	11	PC1/A1
A	30	RESERVED	A	10	PC2/A2
B	30	RESERVED	B	10	PC3/A3
A	29	RESERVED	A	9	PC4/A4
B	29	RESERVED	B	9	PC5/A5
A	28	VSS	A	8	PC6/A6
B	28	PG0/IRQ6_N	B	8	PC7/A7
A	27	PG1/CS3_N/IRQ7_N	A	7	VSS
B	27	PG2/CS2_N	B	7	PB0/A8/TIOCA3
A	26	PG3/CS1_N	A	6	PB1/A9/TIOCB3
B	26	PG4/CS0_N	B	6	PB2/A10/TIOCC3
A	25	VSS	A	5	PB3/A11/TIOCD3
B	25	PF0/BREQ_N/IRQ2_N	B	5	PB4/A12/TIOCA4
A	24	PF1/BACK_N/BUZZ	A	4	PB5/A13/TIOCB4
B	24	PF2/WAIT_N	B	4	PB6/A14/TIOCA5
A	23	PF3/LWR_N/ADTRG_N/IRQ3_N	A	3	PB7/A15/TIOCB5
B	23	PF4/HWR_N	B	3	VSS
A	22	PF5/RD_N	A	2	PA4
B	22	PF6/AS_N	B	2	PA5
A	21	PF7/@	A	1	PA6
B	21	VSS	B	1	PA7

NOTE :

* When target is connected, user has to “ground” the pin CABLE_IN_N.

EXTAL Pin can only accept Oscillating Clock.

User Pins Not available are: FWE, XTAL, CVCC, OSC1 and OSC2..

User Connector 2 - Pin Assignment

Column	Pin	Description	Column	Pin	Description
A	40	VSS	A	20	RESERVED
B	40	P10/TIOCA0/A20	B	20	P60
A	39	P11/TIOCB0/A21	A	19	P61
B	39	P12/TIOCC0/TCLKA/A22	B	19	P62
A	38	P13/TIOCD0/TCLKB/A23	A	18	P63
B	38	P14/TIOCA1/IRQ0_N	B	18	P64
A	37	P15/TIOCB1/TCLKC	A	17	P65
B	37	P16/TIOCA2/IRQ1_N	B	17	P66
A	36	P17/TIOCB2/TCLKD	A	16	P67
B	36	VSS	B	16	VSS
A	35	P20	A	15	P70/TMRI01/TMCI01/CS4_N
B	35	P21	B	15	P71/TMRI23/TMCI23/CS5_N
A	34	P22	A	14	P72/TMO0/CS6_N
B	34	P23	B	14	P73/TMO1/CS7_N
A	33	P24	A	13	P74/TMO2/MRES_N
B	33	P25	B	13	P75/TMO3/SCK3
A	32	P26	A	12	P76/RxD3
B	32	P27	B	12	P77/TxD3
A	31	VSS	A	11	VSS
B	31	P30/TxD0	B	11	P80
A	30	P31/RxD0	A	10	P81
B	30	P32/SCK0/SDA1/IRQ4_N	B	10	P82
A	29	P33/TxD1/SCL1	A	9	P83
B	29	P34/RxD1/SDA0	B	9	P84
A	28	P35/SCK1/SCL0/IRQ5_N	A	8	P85
B	28	P36	B	8	P86
A	27	P37	A	7	VSS
B	27	VSS	B	7	P90
A	26	P40/AN0	A	6	P91
B	26	P41/AN1	B	6	P92
A	25	P42/AN2	A	5	P93
B	25	P43/AN3	B	5	P94
A	24	P44/AN4	A	4	P95
B	24	P45/AN5	B	4	P96/DA0
A	23	P46/AN6	A	3	P97/DA1
B	23	P47/AN7	B	3	VSS
A	22	VSS	A	2	PA0/A16
B	22	P50	B	2	PA1/A17/TxD2
A	21	P51	A	1	PA2/A18/RxD2
B	21	P52	B	1	PA3/A19/SCK2

NOTE :

* When target is connected, user has to “ground” the pin CABLE_IN_N.

EXTAL Pin can only accept Oscillating Clock.

User Pins Not available are: FWE, XTAL, CVCC, OSC1 and OSC2..

Appendix B : User Connector Specification

Part Number of User Connectors:

KEL 1.27mm(50mil) PITCH Plug = 8830E-080-170S
 KEL Cable Assembly = 8822E-080-171-040-AC

NOTE: The pin assignment of the user connector in Appendix A refers to the definition of the pins at the target side, but not the Compact emulator side. User is advised to refer to the cable assembly illustration to avoid confusion.

[A1 (Target) = a40 (Compact Emulator)....
 A40 (Target) = a1 (Compact Emulator)]

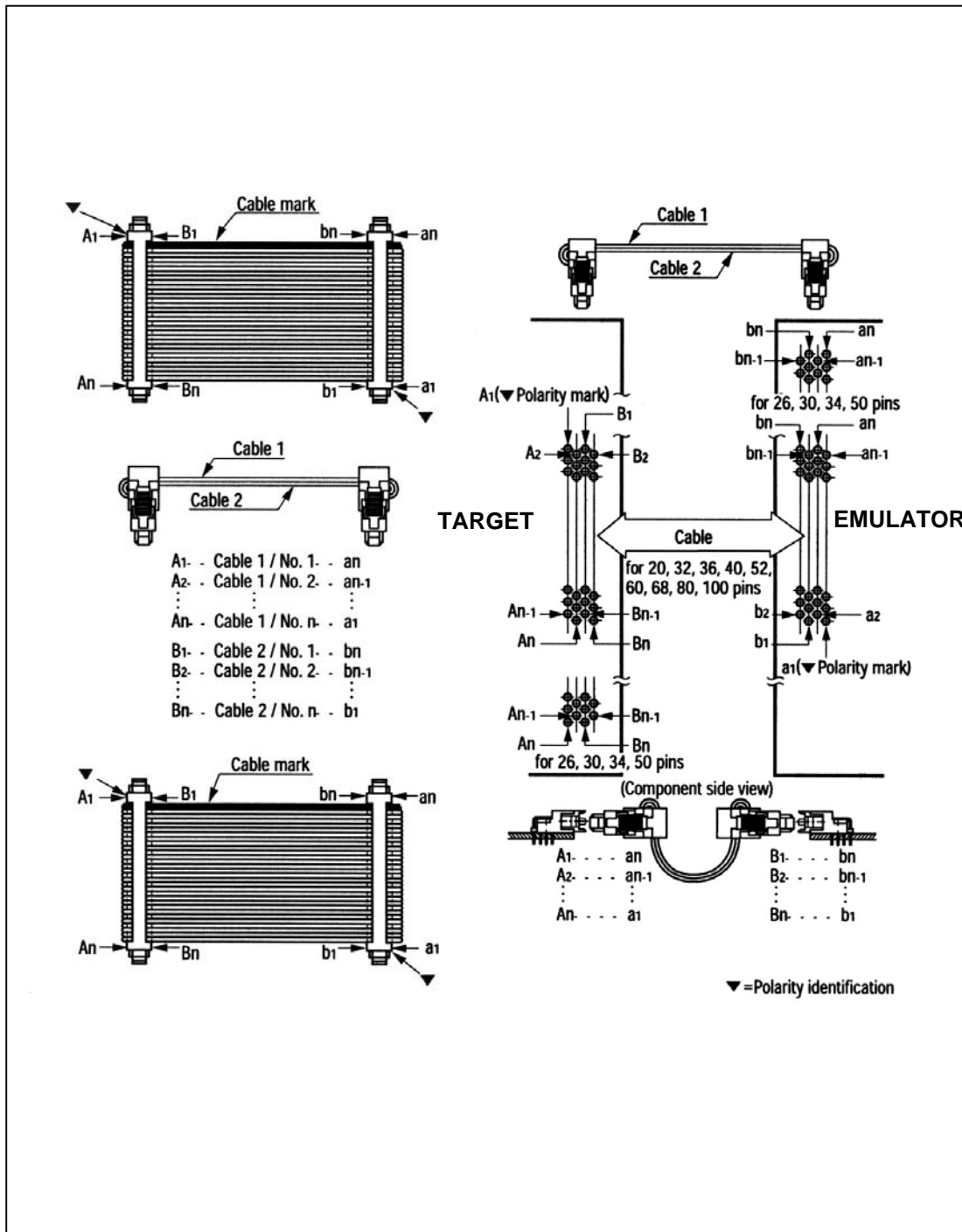

Part Number: 8830E-080-170S

Unit :mm (inch)

X-X' Cross Section

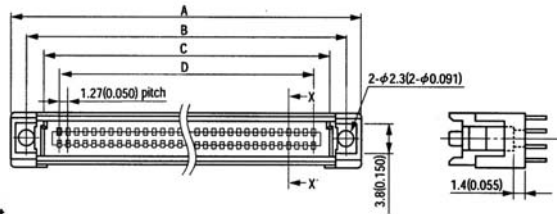
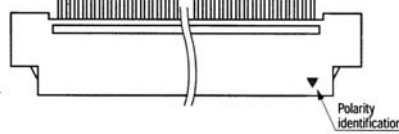
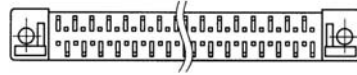
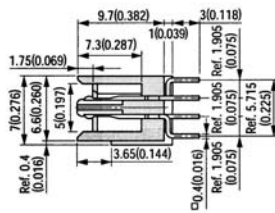

Printed Circuit Board Layout (Component Side View)

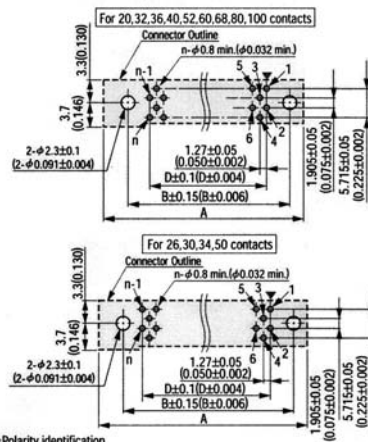

▼ = Polarity identification
 Recommended PCB Thickness $t=1.6\pm 0.19(0.063\pm 0.007)$
 *n is number of contacts.

Appendix C : User Connector Pin Layout

CON2

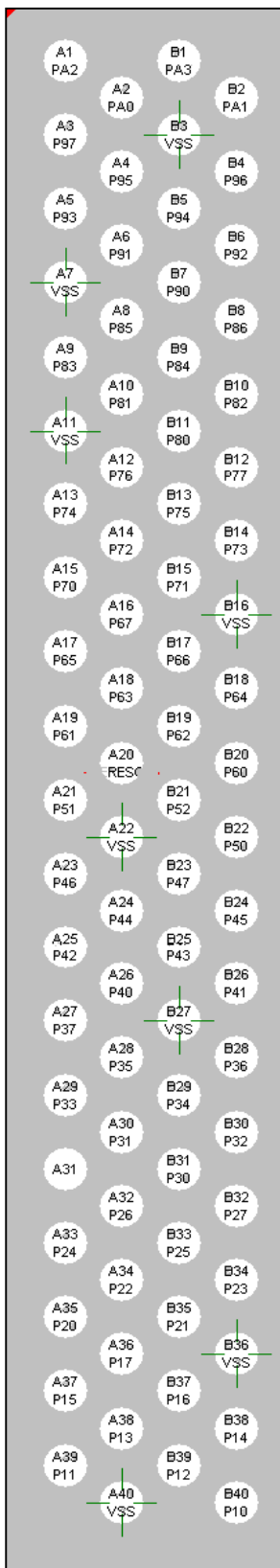

CON1

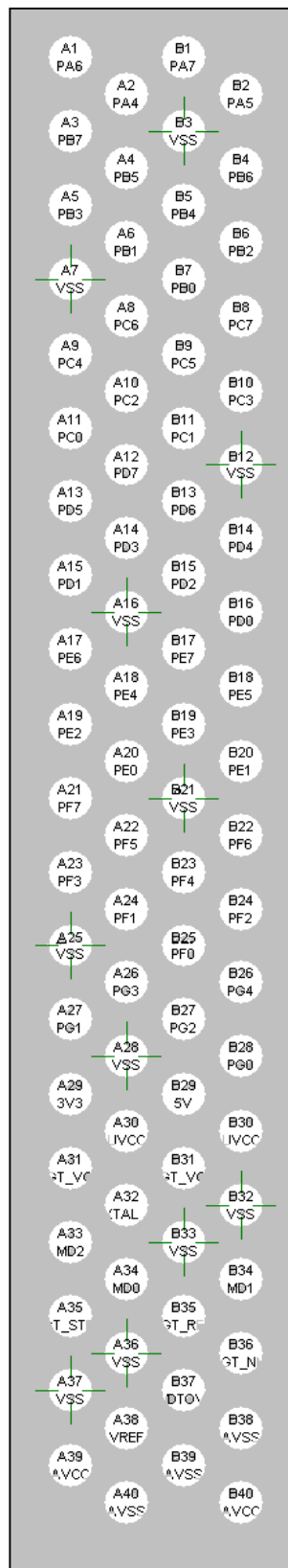

Compact Emulator

Component View At Target

Appendix D : Casing Assembly

6x Ø2mm Screws

For fastening daughter board to main board



4x Ø3mm Screws

For fastening PCB to casing



Connection to target system

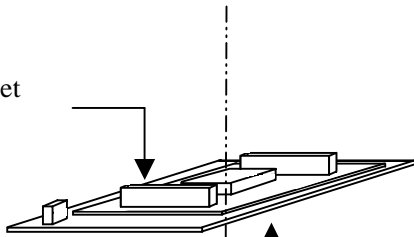

Connection to optional memory, SODIMM

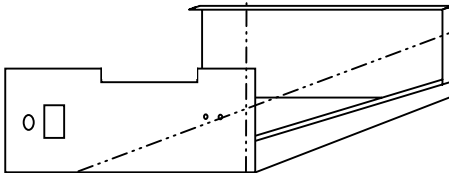
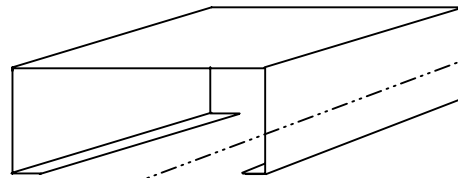

4x Ø3mm Screws

For fastening cover to the base of the casing

Appendix E : Technical Specification

Physical Characteristics

Item		Specification
CE2000 main unit	Dimensions	145 x 120 x 60 mm (l x w x h)
	Weight	1Kg
Power Supply Adaptor	Dimensions	85 x 45 x 35 mm (l x w x h)
	Weight	0.2Kg
Power Supply Adaptor Cable	Length	1.89M
PC Interface Cable	Length	1.0m
User Interface Cable	Length	0.3m

Environmental Conditions

Item		Specification
Temperature	Operating	10°C to 35°C
Relative Humidity (non-condensing)	Operating	30% to 85%
Corrosive Gas		None

Electrical Characteristics

CE2000

Item	Specification
Maximum Operating Condition	
Supply voltage	-0.3 to 7.0V
Supply current	2.6A maximum
Target Supply voltage	-0.3 to 7.0V

Power Supply Adaptor

Item	Specification
Input	110/230V 47-63 Hz
Output	4.75-5.25 Volt
	2.6A/ + 5% overload

Appendix F : Frequently Asked Questions

1. **WHY DIDN'T THE CLOCK INPUT TOGGLE IN THE PINVIEW WINDOW?**
2. **CAN CE WORK WITH OTHER USB DEVICES?**
3. **WHAT IS POTF? WHAT CAN IT DO?**
4. **HOW TO DISABLE THE POTF FUNCTION?**
5. **HOW TO MINIMIZE THE INTRUSION OF THE POTF?**
6. **HOW MUCH CURRENT WILL THE EMULATOR DRAW FROM THE TARGET SYSTEM?**
7. **WHY IS THE PROGRAM HALTED AT AN ADDRESS THAT IS NOT SPECIFIED IN THE PRESET COMBINATION BREAKPOINT?**
8. **WHAT IS THE CABLE_IN_N SIGNAL USED FOR?**
9. **HOW ABOUT MODE, CLOCK , RES, NMI & STBY SIGNALS? HOW DOES THE EMULATOR CONTROL THESE SIGNALS?**
10. **WHY IS STBY PIN MASKED IN DEFAULT?**
11. **WHY IS C-LEVEL STEPPING NOT POSSIBLE?**
12. **WHY MUST THE PROGRAMMABLE FUNCTION GENERATOR (PFG) BE PROGRAMMED AT POWER UP? WHAT IS THE PFG USED FOR?**
13. **WHY IS THE STATE CHANGES OF PORT NOT REFLECTED IN THE PINVIEW WINDOW?**
14. **WHY CAN'T THE TWO MBYTES OF OPTIONAL MEMORY BE UTILIZED FULLY?**
15. **WHY CAN'T THE OTP WORK AS ACCORDINGLY?**
16. **WHY IS THE SELECTION OF "TARGET CLOCK " NOT AVAILABLE IN THE SYSTEM SETUP WINDOW?**

1. **Why didn't the clock input toggle in the PinView window?**

The pinview window read the Pins status from the emulator at a constant interval. Thus, there is a possibility that it always snaps the same level from the chip.

2. **Can CE work with other USB devices?**

CE can work with other USB devices. If another hub is used, CE must be the last device to be plugged-in.

3. **What is POTF? What can it do?**

POTF stands for Parallel On The Fly. It can read or write memory while the user program is running. In this way, user can have the instant view of the outcome of the executing program. In order to access these memory, the emulator will "stop" the running program for a short interval, approximately 150 ns, for a word access.

4. **How to disable the POTF function?**

As long as the user do not modify the memory contents or perform a refresh memory window command, POTF function will not be activated to intrude the real time operation of the user program.

5. How to minimize the intrusion of the POTF?

POTF will be activated based on the HEW commands, such as memory edit or refresh. If several memory windows are opened, HEW will read back all the windows content. Thus, user is advised to open the memory window at minimal size, in order to avoid unnecessary intrusion.

6. How much current will the emulator draw from the target system?

The emulator will not consume the target system supply. It will generate an user VCC for internal usage, which has an identical level as the target system power supply.

7. Why is the program halted at an address that is not specified in the preset combination breakpoint?

The emulator will break out of the user code execution once it has detected the preset condition. However the emulator will not stop execution immediately as it has to complete its current tasks, thus the code will not break at its preset address.

Another point to note is the prefetch condition, if the preset condition matches the prefetch instruction, the emulator will also enter the break mode.

The worst case scenario is: if a break condition is set at the beginning of subroutine B, which codes are stacking behind subroutine A. A break condition will happen when subroutine A is called. This is due to the prefetching of subroutine B code when subroutine A is returning to the main routine.

8. What is the CABLE_IN_N signal used for?

This signal is used by the emulator to identify target connection. When CABLE_IN_N is lo, the emulator will know that target is connected, and the power supply will be switched to follow the target power supply.

9. How about Mode, Clock , RES, NMI & STBY signals? How does the emulator control these signals?

Generally, the emulator will control all the above signals. The only uncontrollable item will be the target power supply. The emulator will follow the target supply once the cable is detected. User has to set the above signals in the *Configure Platform* dialog. User can set the Mode & Clock signal to follow the target system or any options that is available in the selection. The RES & NMI pins are set to follow the target in default. User can choose to mask these signals in the configure window. STBY is masked in default.

10. Why is STBY pin masked in default?

STBY pin will initialise some of the emulator registers. Thus, user is advised not to use the signal unless necessary.

11. Why is C-Level Stepping not possible?

If the disassembly window is opened, the step-in instruction will command a single step execution of the assembly code. User has to close the disassembly windows. This will inform the system to perform C-Level stepping of the loaded C-code.

12. Why must the Programmable Function Generator (PFG) be programmed at power up? What is the PFG used for?

The PFG is implemented using a RAM-based FPGA. Thus it must be programmed at power-up. The PFG is implemented for its flexibilities. A single chip FPGA is used to implement the PFG which can be programmed to any functions that can help user to debug their target system. Please feedback your needs to the design group so that more effective functions can be developed.

13. Why is the state changes of port not reflected in the Pinview window?

The pinview module gives an snapshot of the microcomputer pins at constant interval. It is not an oscilloscope that can snap signal as fast as 2ns. It is a tool used to help user to have a feel of the status of the microcomputer pins. It will be very helpful when it is at static state. User can track any discontinuity in the emulator to target connection.

14. Why can't the two Mbytes of optional memory be utilized fully?

The two Mbytes of optional memory consists of 4 x 512Kbytes of memory. Each memory is selected based on the upper address. Thus, if user intends to use the whole memory at a starting address that is not multiple of 512Kbytes, user will not be able to utilize the full memory capacity (e.g. if the external address begin at H'20000). However, if external address begin at H'0, as in the ROMless mode, user will be able to map the whole 2Mbytes space (H'0 to H'1F FFFF).

15. Why can't the OTP work as accordingly?

User has to note the differences as stated in the user manual, such as the initialization of registers (SP...), the delay of signals (about 4ns of cabling delay...), the unused pins (OSC1, OSC2, CVCC...), the regenerated power supply for emulator, the smoothed main clock signal, ...

16. Why is the selection of "target clock " not available in the system setup window?

HEW will disallow the target selection if the target is not available (The Signal CABLE_IN_N is Hi).

Renesas Technology (Asia Sales Offices)

URL: <http://www.renesas.com>

CE2000

