

USER'S MANUAL



TRIAC POWER CONTROLLER FOR ELECTRIC HEATERS

RNS-16

RNS-25



CONTENTS



Safety requirements	3
Purpose	5
Delivery set	5
Designation key	5
Technical data	6
Design and operating principle	8
Mounting and set-up	10
Connection to power mains	12
Technical maintenance	17
Transportation and storage regulations	17
Manufacturer's warranty	18
Acceptance certificate	20
Seller information	20
Installation certificate	21
Warranty card	21

This user's manual consisting of the technical details, operating instructions and technical specification covers the installation and mounting of the RNS triac power controller (hereinafter referred to as «the controller» or «the unit» as mentioned in the «Safety requirements» and «Manufacturer's warranty» sections as well as in warnings and information blocks).

■ SAFETY REQUIREMENTS

- Read the user's manual carefully prior to installing and operating the unit.
- Fulfil the user's manual requirements as well as the provisions of all the applicable local and national construction, electrical and technical norms and standards.
- The warnings contained in the user's manual must be considered most seriously since they contain vital personal safety information.
- Failure to follow the rules and safety precautions noted in this user's manual may result in an injury or unit damage.
- After a careful reading of the manual, keep it for the entire service life of the unit.
- While transferring the unit control the user's manual must be turned over to the receiving operator.

Symbol legend:

	WARNING!
	DO NOT!

UNIT MOUNTING AND OPERATION SAFETY PRECAUTIONS



- Disconnect the unit from power mains prior to any installation operations.



- The unit must be grounded!



- Do not lay the power cable of the unit in close proximity to heating equipment.



- While installing the unit follow the safety regulations specific to the use of electric tools.



- Do not change the power cable length at your own discretion.
- Do not bend the power cable.
- Avoid damaging the power cable.
- Do not put foreign objects on the power cable.



- Do not operate the unit outside the temperature range stated in the user's manual.
- Do not operate the unit in aggressive or explosive environments.



- Do not use damaged equipment or cables when connecting the unit to power mains.



- Unpack the unit with care.



- Do not touch the unit controls with wet hands.
- Do not carry out the installation and maintenance operations with wet hands.



- Do not wash the unit with water.
- Protect the electric parts of the unit against ingress of water.



- Do not allow children to operate the unit.



- Disconnect the unit from power mains prior to any technical maintenance.



- Do not store any explosive or highly flammable substances in close proximity to the unit.



- When the unit generates unusual sounds, odour or emits smoke disconnect it from power supply and contact the Seller.



- Do not open the unit during operation.



- Do not direct the air flow produced by the unit towards open flame or ignition sources.



- Do not block the air duct when the unit is switched on.



- In case of continuous operation of the unit periodically check the security of mounting.



- Do not sit on the unit and avoid placing foreign objects on it.



- Use the unit only for its intended purpose.

WARNING! The controller must only be used for regulating the power output of electric heaters of appropriate capacity.

The total current consumption of the connected electric heaters must be within the limits of the maximum load current (see «Technical data»).

Avoid running the controller at the maximum load current.

The controller operation requires connection of thermal contacts set to restart the appliance automatically at +50°C and manually at +90°C as well installation of a duct pressure switch.

■ PURPOSE

The RNS three-phase TRIAC power controller is designed for regulating the power output of electric heaters with load current rating up to 120 A.



THE UNIT IS NOT INTENDED FOR OPERATION BY CHILDREN OR PERSONS WITH REDUCED SENSORY OR MENTAL CAPACITY OR THOSE LACKING THE APPROPRIATE TRAINING. THE CONTROLLER MUST BE HANDLED ONLY BY PROPERLY QUALIFIED PERSONNEL AFTER THE APPROPRIATE BRIEFING. THE CHOICE OF UNIT INSTALLATION LOCATION MUST PREVENT UNAUTHORIZED ACCESS BY UNATTENDED CHILDREN.

■ DELIVERY SET

Power controller	1 piece
Temperature sensor	1 piece
User's manual	1 piece
Packaging	1 piece

■ DESIGNATION KEY

RNS-X

**TRIAC power controller
for electric heaters**

**Maximum power output of heater connected
to first cascade of controller, [kW]**

■ TECHNICAL DATA

RNS Characteristics:

- 230 V single-phase or 400 V three-phase load connection (see wiring diagram on pages 13-16).
- Proportional supply air temperature sensing control.
- Expandable with two booster heating cascades. The power output of each of the two booster cascades may not exceed the power output of the regulated heater cascade.

RNS operating modes:

- 1 Maintaining the pre-set duct temperature according to the duct temperature sensor feedback.
- 2 Regulation of the heating output within the 0 to 100 % range by using the 0-10 V control input.

The controller is connected in series between the power supply unit and the star-connected or delta-connected electric heater. Delta circuits allow for simultaneous connection of various capacity loads.

The controller is intended for wall mounting.

Controller Appearance:

- 1 ON/OFF button.
- 2 Heating temperature control knob (from -30 °C up to +30 °C).
- 3 Indicators.

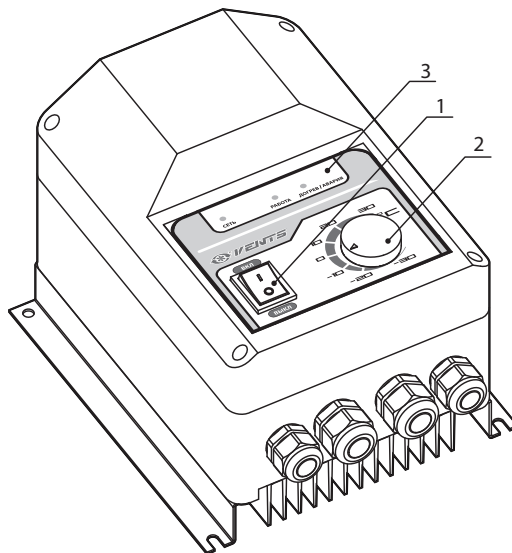

Parameters	RNS-16	RNS-25
Max. load current (single cascade), [A]	25	40
Heater output (single cascade), [kW]	16	25
Max. load current (three cascades), [A]	-	120
Heater output (three cascades), [kW]	-	75
Control circuit supply voltage	~230 V / 50 Hz	
Nominal current of control circuit board fuse, [A]	0,5	
Cross-section area of screw terminal block input pin, [mm ²]	4...10	
Protection class	IP54	
Outside dimensions, [mm]	170x255x140	
Weight, [kg]	1,2	
Electric mains parameters: Voltage, [V] Frequency, [Hz] Phases	210-255, 380-415 50-60 1 or 3	
Operating temperature range, [°C]	+5...+40	

Note: Intrinsic heat generation: RNS-16 controller – 50 W, RNS-25 controller – 80 W.

Control parameters	
Regulation time, [s]	0.1 (fixed)
Cycle length, [s]	1...10 (adjustable)
Indication	Power, operation and emergency indicator
Type of temperature sensor used	LM 60
Input signal parameters, [V]	0...10 (direct current)
Set temperature range, [°C]	from -30 to +30 (adjustable)

■ DESIGN AND OPERATING PRINCIPLE

Electric power output is regulated by proportional connection and disconnection of the full load depending on the pre-set heating temperature.

For example, intermittent connection and disconnection of the load in 5 s intervals generates 50 % of the maximum output.

The cycle length - i.e. the combined period of load connection and disconnection - is adjustable within the 1 to 10 s range.

Reduction of the total cycle length increases the heating intensity and output temperature variance amplitude.

The RNS-16 capabilities are limited to only one heating cascade.

Unlike the smaller model the RNS-25 is capable of controlling one or three heating cascades with the power output equal or exceeding that of the controlled cascade.

The power output of the first cascade is controlled in a stepless manner by switching the full load on and off.

The second and third cascades are controlled in steps.

For example, if the first cascade power output is insufficient for reaching the pre-set temperature, the second cascade of the electric heater engages at 100 % capacity whereas the first cascade output is dropped to 0 % and then increased to the required level to ensure reaching the target temperature.

To connect two extra heating cascades install an electric contactor for activating each heater cascade.

For overheating protection the electric heater must be equipped with two built-in thermal contacts: TK50 with intervention temperature of +50 °C and automatic restarting and TK90 with intervention temperature of +90 °C and manual restarting.

The air temperature is set by means of the integral pot resistor or an external control device generating a 0-10 V control input signal for increasing the duct temperature proportionally in the range from -30 to +30 °C.

The duct temperature sensor must be installed downstream of the heater in the direction of the air stream travel at the minimum distance of 50 cm from the heater.

If the controller runs in the heating power output mode irrespective of the temperature sensor feedback, no duct temperature sensor is necessary whereas the heating power output is regulated in the 0 to 100% range by means of the 0-10 V control input signal.

CAUTION! Ensure a constant airflow to the heating elements of the heater while the RNS is operational.

The fan choice must account for the minimum air flow through the heater of 1.5 m/s.

The blowing fan of the heating element must operate for at least two minutes after the system shutdown.

FUNCTIONAL SWITCHES AND INDICATORS

There are three lights on the indicator panel:

- Power – **AC mains** (green);
- Current state – **operation** (yellow) and **alarm/booster heating** (red).



Current state and malfunction indication

AC mains - green	Operation - yellow	Alarm - red	EVENT
-	-	-	AC mains disconnected

Temperature sensor feedback operation

ON	BLINKING	-	«Temperature boosting: T set > T flow»
ON	ON	-	«Reaching mode parameters: T set = T flow»

Power output mode

ON	BLINKING	-	The blinking frequency is proportional to the power supplied to the heating elements.
----	----------	---	---

Alarms

ON	-	ON	TK50 thermal contact actuation
ON	-	BLINKING	Duct pressure switch signal lost or no enabling signal
ON	-	BLINKING double intermittent	Temperature sensor shorting or sensed value out of range (t < -40 0C)
ON	-	BLINKING triple intermittent	Temperature sensor breakout or sensed value out of range (t < +90 0C)

CAUTION! After transporting or storing at subzero temperatures subject the unit to room temperature for at least 4 hours before connecting it to the electric mains.

- Inspect the unit visually and check the casing for integrity.
- Attach the controller to the mating surface by using the holes in the mounting plates of the unit.

CAUTION!
THE CONTROLLER IS
INTENDED FOR VERTICAL
MOUNTING ONLY!

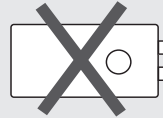
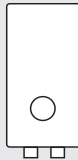

- Undo the self-tapping screws 3 and remove the controller front lid. If necessary, disconnect the flexible flat cable.
- Connect the controller to the electric mains according to the connections diagram. Route the electric power cables into the casing through sealed lead-ins 4 and secure them with the terminal screws 5 on the block. The stationary wiring must be equipped with an automatic circuit breaker. The connection must be made via an automatic circuit breaker integrated into the stationary wiring.
- Replace the controller front lid.
- Supply the power voltage to the unit.
- Press the On/Off button 1 and set the desired temperature by turning the temperature control knob 2.

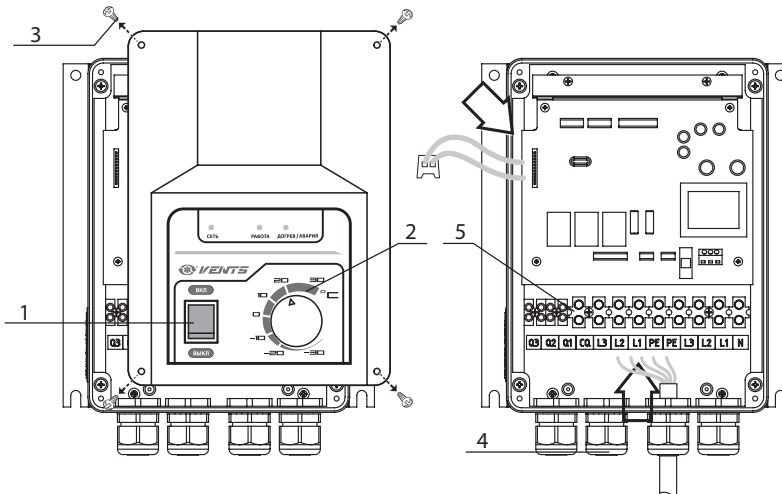

CONNECTION TO POWER MAINS

External connections diagram

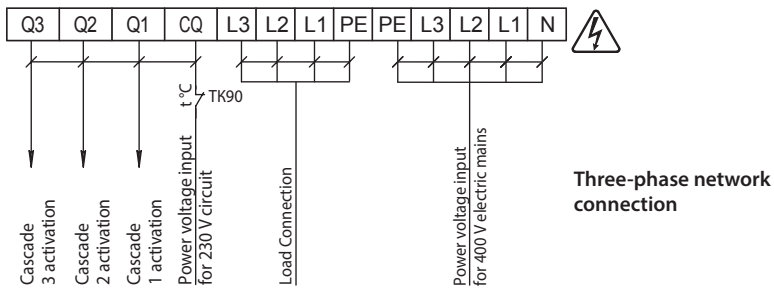
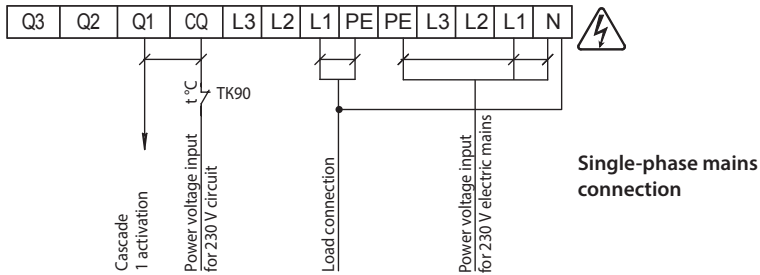

Command unit connection diagrams

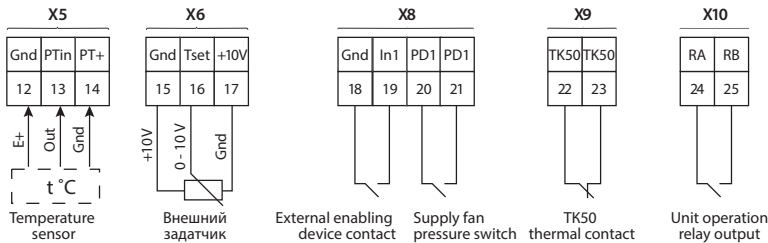

Electrical connections diagrams

To enable several heating cascades install a dedicated electric contactor for each heating cascade.

Connect the contactors to the terminal block via the relay outputs according to the external connections diagram.

Send the contactor supply voltage to the «CQ» input via the TK90 protective thermal contact of the heater (thermal contact for calorifier protection, Tact.=90 °C) to enable the contactors.

Power the Q1 first heating cascade via the L1, L2, L3, and PE load connection terminals.

Connect the remaining cascade contactors to the external network.

The contactor becomes redundant if only one heating cascade is used.

In this case the control circuit board power supply should be connected via the TK90 protective thermal contact.

The K1, K2, K3 electric contactors (starter switches) and the QF1 automatic circuit breaker (see connection diagrams on pages 13-16) are purchased separately.

Diagram for RNS-25 Triple-Cascade Controller Connection to Three-Phase Electric Mains

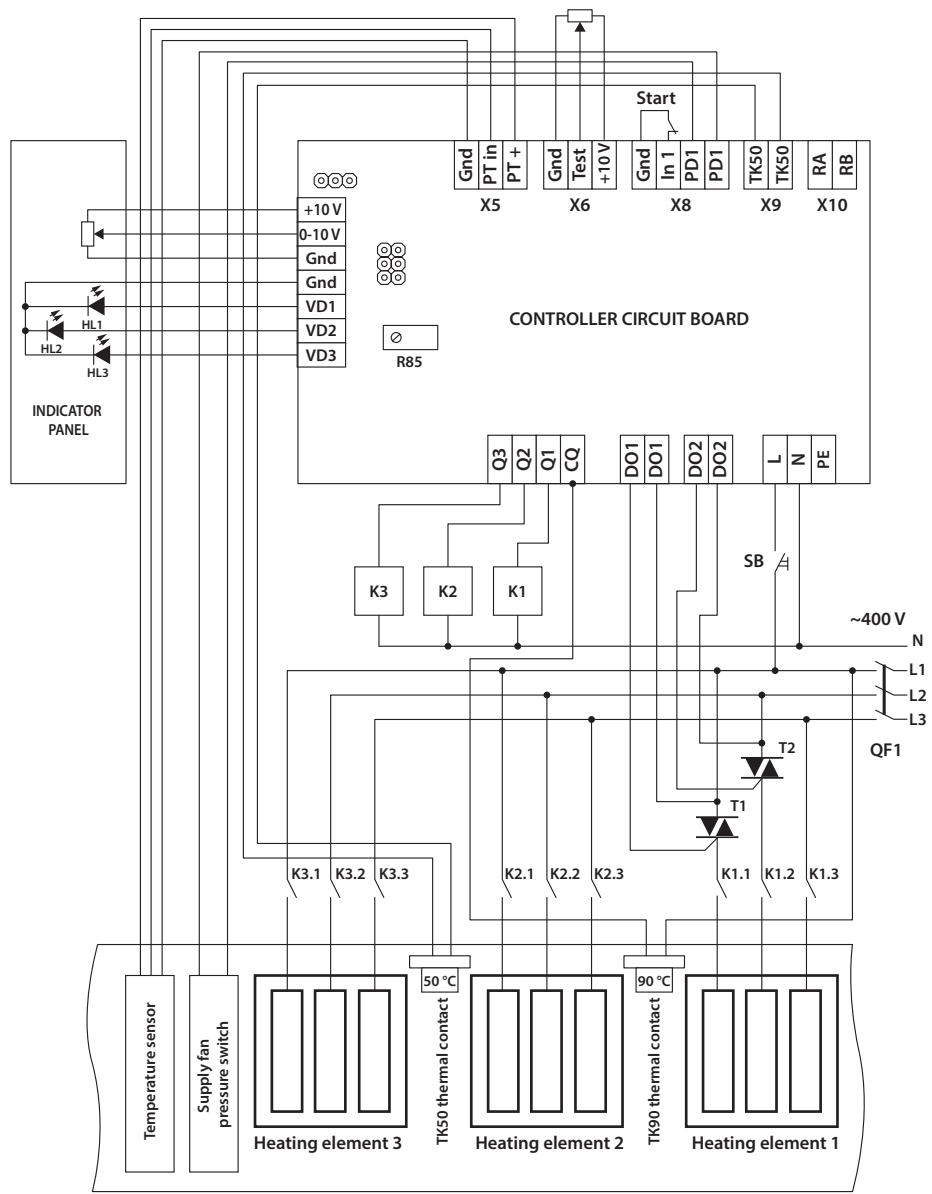

Diagram for RNS-25 triple-cascade controller connection to single-phase electric mains

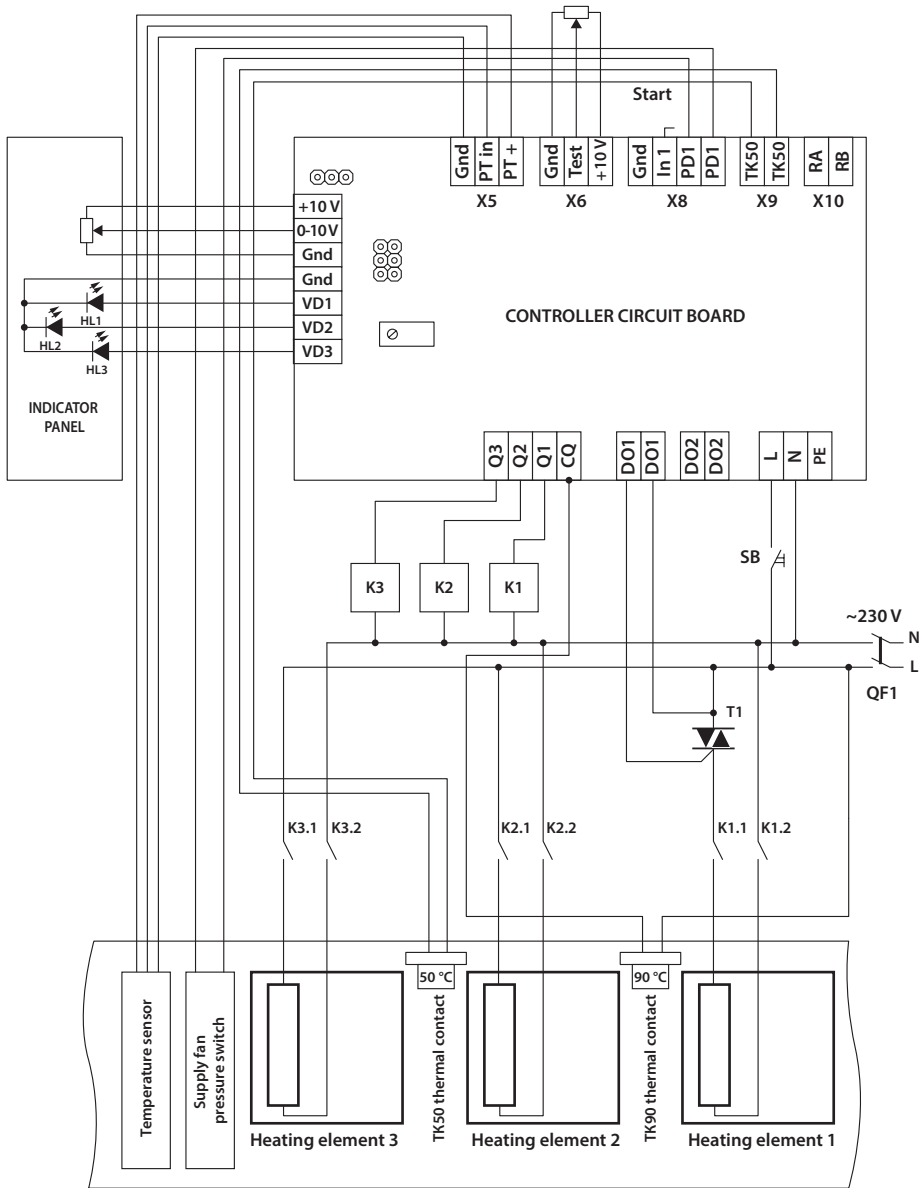

Diagram for RNS-16 and RNS-25 single-cascade controller connection to three-phase electric mains

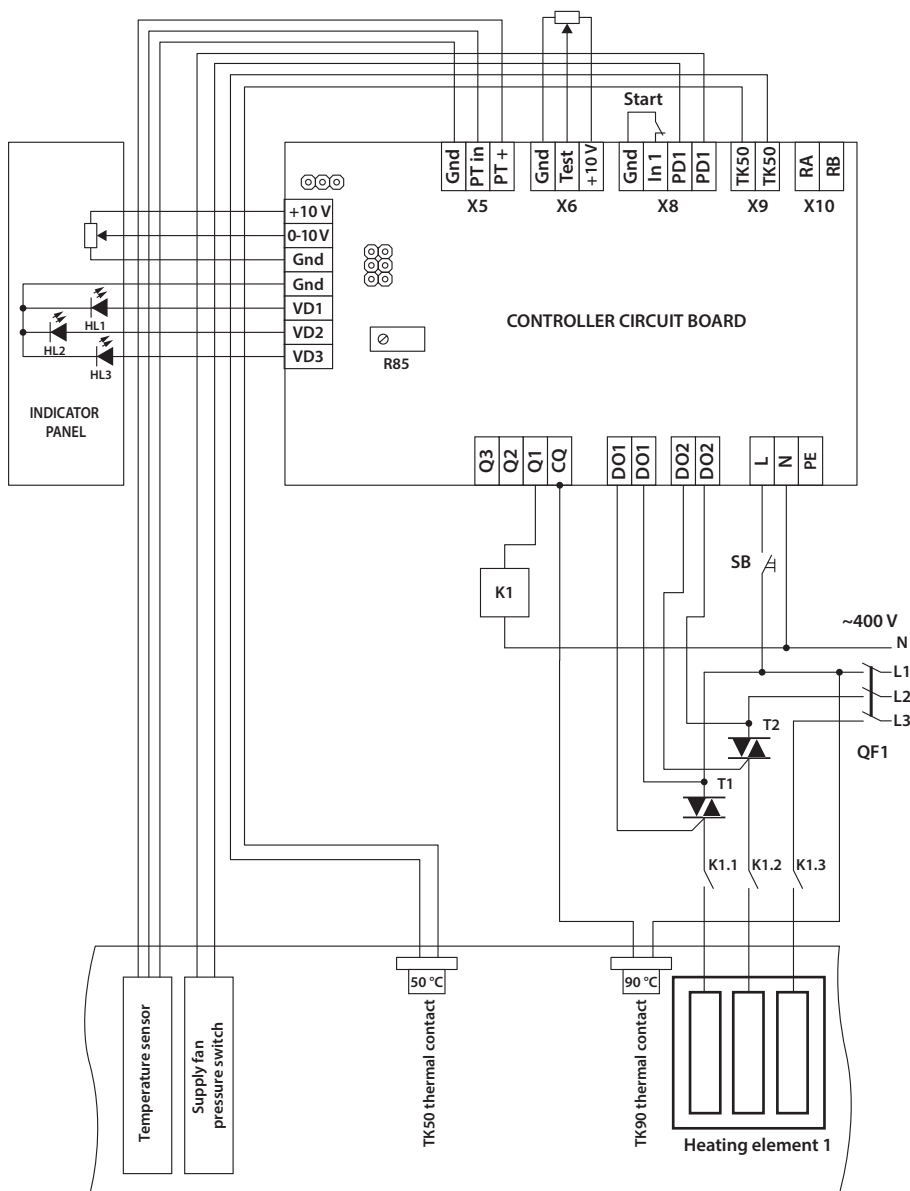
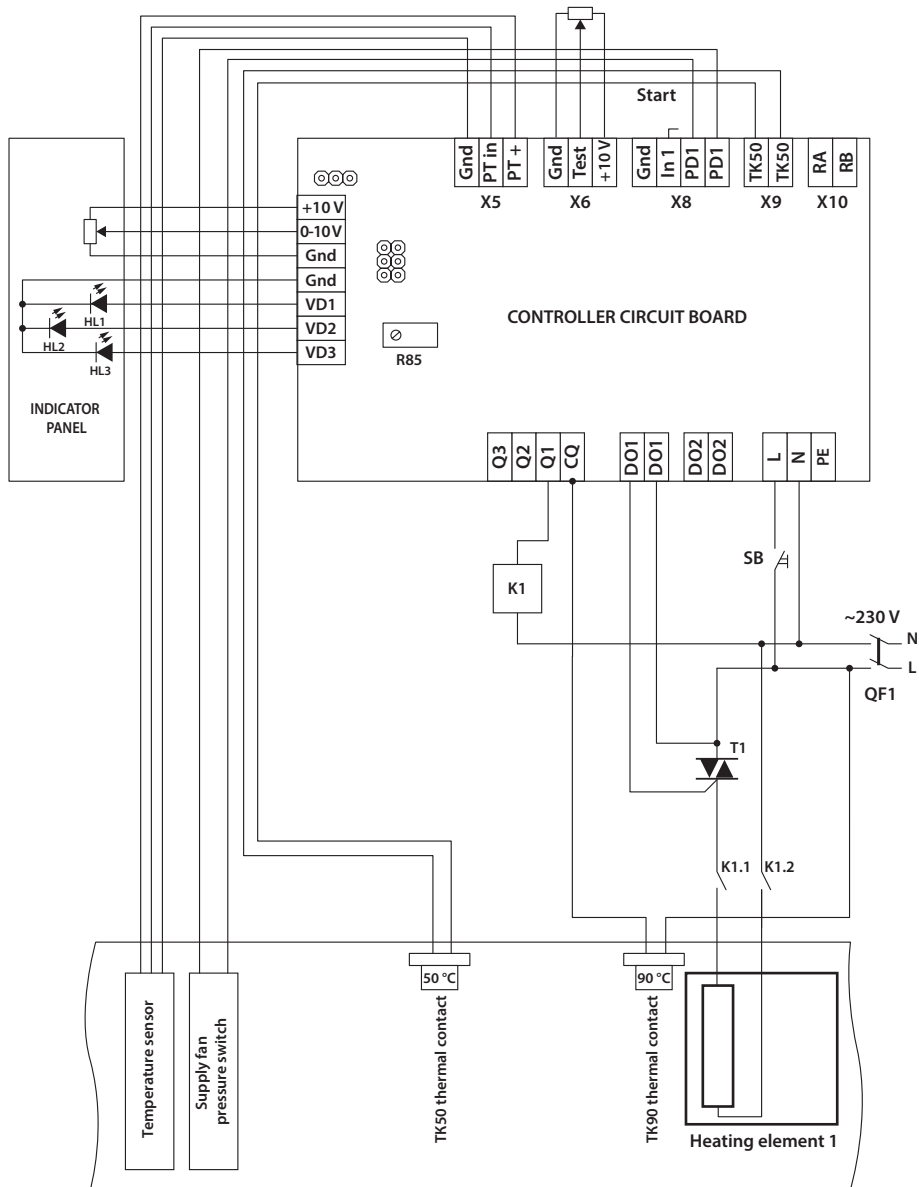

Diagram for RNS-16 and RNS-25 single-cascade controller connection to single-phase electric mains



■ TECHNICAL MAINTENANCE

- Make sure to schedule a periodic inspection of the external electrical leads connection to the bolt-down terminals of the unit.

Possible malfunctions and their elimination

Problem	Possible reasons	Troubleshooting
Controller will not switch on	The unit is not connected to the power mains.	Make sure that the unit is properly connected to the power mains and make any corrections, if necessary.
	Faulty fuse.	Replace the fuse.
Heating element overheating	The heater power output does not match the power output controller parameters.	Check the heater power output for compliance with the RNS controller specifications. Install an appropriately rated heater.
	Filter clogging.	Clean the filter.
	Insufficient heating element air cooling or no air cooling.	Eliminate the factors preventing proper air cooling of the heating element.
Controller malfunction	Temperature sensor malfunction.	Replace the temperature sensor.
	Incorrect operating mode selection.	Check the jumpers for correct installation (see Page 10).

■ TRANSPORTATION AND STORAGE REGULATIONS

The unit must be stored in the original packing in a dry ventilated area at temperatures from +5 °C to +40 °C.

The air in the storage space must not contain any vapours or admixtures which may lead to corrosion or compromise the insulation and seals.

Use only suitable lifting equipment for handling operations to prevent damage to the unit.

Follow the applicable moving regulations specific to the particular cargo type while loading and unloading.

The unit can be transported in the original packing by any mode of transport without limitation provided proper protection against precipitation and mechanical damage.

Avoid sudden jolts and impacts while loading and unloading the unit.

■ MANUFACTURER'S WARRANTY

The manufacturer hereby warrants normal operation of the unit for 12 months after the retail sale date provided the user's observance of the transportation, storage, mounting and operation regulations.

Should any malfunctions occur in the course of the unit operation through the Manufacturer's fault during the guaranteed period of operation the user is entitled to elimination of faults by the manufacturer by means of warranty repair at the factory free of charge.

The warranty repair shall include work specific to elimination of faults in the unit operation to ensure its intended use by the user within the guaranteed period of operation.

The faults are eliminated by means of replacement or repair of the unit components or a specific part of such unit component.

The warranty repair does not include:

- routine technical maintenance
- unit installation / dismantling
- unit setup

To benefit from warranty repair the user must provide the unit, the user's manual with the purchase date stamp and the payment document certifying the purchase.

The unit model must comply with the one stated in the user's manual.

Contact the Seller for warranty service.

The manufacturer's warranty does not apply to the following cases:

- User's failure to submit the unit with the entire delivery package as stated in the user's manual including submission with missing component parts previously dismantled by the user.
- Mismatch of the unit model and the brand name with the information stated on the unit packing and in the user's manual.
- User's failure to ensure timely technical maintenance of the unit.
- External damage to the unit casing (excluding external modifications as required for installation) and internal components caused by the user.
- Redesign or engineering changes to the unit.
- Replacement and use of any assemblies, parts and components not approved by the manufacturer.
- Unit misuse.
- User's violation of the unit installation regulations.
- User's violation of the unit control regulations.
- Unit connection to the power mains with a voltage different from the one stated in the user's manual.
- Unit breakdown due to voltage surges in the power mains.
- Discretionary repair of the unit by the user.
- Unit repair by any persons without the manufacturer's authorization.
- Expiration of the unit warranty period.
- User's violation of the unit transportation regulations.
- User's violation of the unit storage regulations.
- Wrongful actions against the unit committed by third parties.
- Unit breakdown due to circumstances of insuperable force (fire, flood, earthquake, war, hostilities of any kind, blockades).
- Missing seals if provided by the user's manual.
- Failure to submit the user's manual with the unit purchase date stamp.
- Missing payment document certifying the unit purchase.



FOLLOWING THE REGULATIONS STIPULATED HEREIN WILL ENSURE A LONG AND TROUBLE-FREE OPERATION OF THE UNIT.



USERS' CLAIMS SHALL BE A SUBJECT TO REVIEW ONLY UPON PRESENTATION OF THE UNIT, THE PAYMENT DOCUMENT AND THE USER'S MANUAL WITH THE PURCHASE DATE STAMP.

■ ACCEPTANCE CERTIFICATE

Unit Type	TRIAC POWER CONTROLLER FOR ELECTRIC HEATERS
Model	RNS _____
Serial Number	
Manufacture Date	
<p>«is compliant with the technical specifications and is hereby declared ready for service. We hereby declare that the product complies with the essential protection requirements of Electromagnetic Council Directive 2004/108/EC, 89/336/EEC and Low Voltage Directive 2006/95/EC, 73/23/EEC and CE-marking Directive 93/68/EEC on the approximation of the laws of the Member States relating to electromagnetic compatibility. This certificate is issued following test carried out on samples of the product referred to above.»</p>	
Quality Inspector's Stamp	

■ SELLER INFORMATION

Seller	
Address	
Phone Number	
E-mail	
Purchase Date	

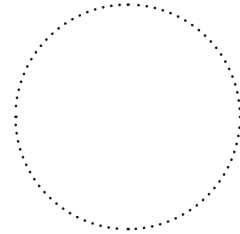

Seller's Stamp

This is to certify acceptance of the complete unit delivery with the user's manual. The warranty terms are acknowledged and accepted.

Customer's Signature	
-----------------------------	--

■ MOUNTING CERTIFICATE

The unit has been connected to power mains pursuant to the requirements stated in the present user's manual.	
Company Name	
Address	
Phone Number	
Installation Technician's Full Name	
Installation Date:	Signature:

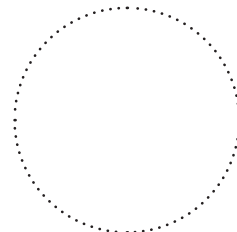

Seller's Stamp

The unit has been installed in accordance with the provisions of all the applicable local and national construction, electrical and technical codes and standards. The unit operates normally as intended by the manufacturer.
Signature:

■ WARRANTY CARD

Unit Type	TRIAC POWER CONTROLLER FOR ELECTRIC HEATERS
Model	RNS _____
Serial Number	
Manufacture Date	
Purchase Date	
Warranty Period	
Seller	

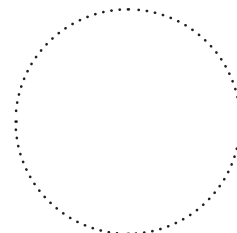

Seller's Stamp







V116-2EN-01

