

DIGITAL NANO-OHMMETER

32000 points autorange $1n\Omega \div 320\Omega$

mod. 20024

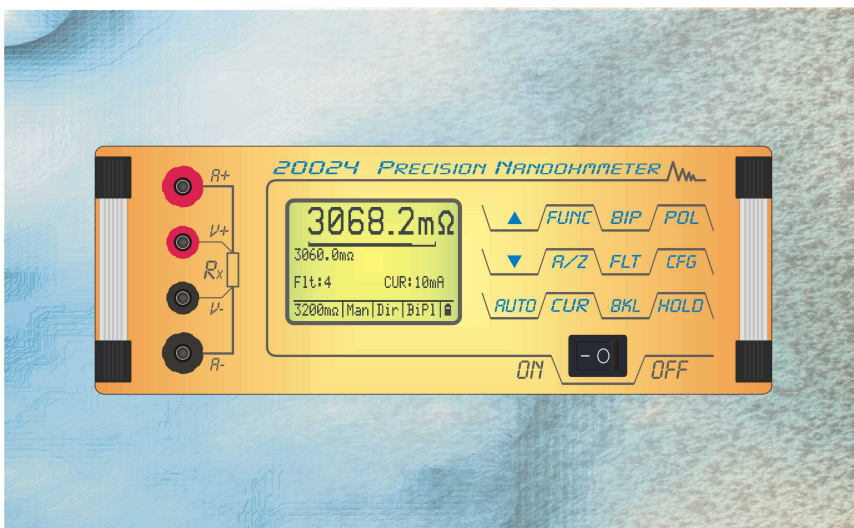

USER MANUAL



PROFESSIONAL MEASURING INSTRUMENTS

INDEX

INTRODUCTION	1
DESCRIPTION	2
AUTO HOLD	3
DEFINITION BUTTONS AND INPUTS	4
BUTTONS	4
INPUTS	13
AUXILIARY INFORMATIONS	14
TECHNICAL SPECIFICATIONS	15
TIPS ON THE MEASUREMENT EXECUTION	18
POTENTIAL OF CONTACT	18
USING THE METHOD OF BIPOLAR MEASURING.	20
MEASUREMENT ON RANGE $32\mu\Omega$	20
ELECTROMAGNETIC FIELDS	21
CURRENT CABLES OF INSUFFICIENT SECTION	22
SLOW OF MEASUREMENT	22
MEASUREMENT OF ELEMENTS HIGHLY INDUCTIVE	22
PROTECTION FROM OVERVOLTAGE AND OVERCURRENT	23
COMMUNICATION PORT	24
GENERALITY	24
READING DATA	24
WRITING SETUP	28

INTRODUCTION

The digital nano-ohmmeter mod. **20024** is a instrument with performance absolutely unique: although size and weight are extremely low, provides resolutions and features never present together so far.

- ▶ *32000 measuring points / 5 measurements per second*
- ▶ *8 ranges from 320 Ohm to 32 uOhm (from 10 mOhm to 1 nOhm of resolution)*
- ▶ *current measurement can be selected*
- ▶ *choice of automatic or manual range measurement*
- ▶ *graphic display*
- ▶ *bar graph*
- ▶ *relative measure both absolute and percentage simultaneously of the main measurement*
- ▶ *temperature compensation of the measure from 0,0°C to 50,0°C*
- ▶ *choice of the polarity of measurement*
- ▶ *automatic measurement in both polarities indicating the average value*
- ▶ *auto-zeroing the instrument*
- ▶ *compensation of test leads*
- ▶ *measurement hold*
- ▶ *choice and display the magnitude of the filtering of the measure*
- ▶ *backlight on/off*
- ▶ *acoustic signaling of the correct selection*
- ▶ *line and battery standard operation*
- ▶ *indication of the state of battery charge*
- ▶ *save/recall of configuration*
- ▶ *reading data and setting via optocoupled USB*
- ▶ *only two commands: one to read all the data and setup and one to write the new setup*

Accuracy, number of measuring points and resolution, as well as reduced size and weight, make the instrument certainly unique and suitable for use both in the laboratory as in the field. Indeed the presence of internal rechargeable batteries shall release from the necessity of the mains voltage with an autonomy that can reach a maximum of about 350 hours.

The main measure is also well represented with large characters 10mm high that allow the reading to three meters away.

The instrument has no menu where you can select the options you want, but only and simply the ability to slide four screens in which:

- ▶ *displays the main measure*
- ▶ *displays the main measure and the relative and absolute percentage*
- ▶ *is set the temperature compensation of the measurement*
- ▶ *displays the measure compensated, the main measure and the temperature*

DESCRIPTION

The instrument is mounted in a aluminum extruded anodized case. Of limited weight, it has the handles to facilitate transportation and swivel feet in order to better view of the display and accessibility to commands and test sockets.

The graphic display 64x128 pixel is very large relative to the size of the instrument, so as to facilitate the reading even from a distance and in low light. Even the arrangement of the information (measuring primary and secondary, settings and indications) has been designed to be easily readable and never create confusion.

The entire instrument is managed by a 16-bit microprocessor, while the technique of measurement is ratiometric four-wire, otherwise known as Kelvin connection, the only one that allows you to get off at accuracies and resolutions so thrusts.

The amplifier and converter are in a monolithic device so as to have an equivalent input noise (with filter = 32) of only 100nVpp typical in a minute and drifts lower than typical 300nVpp in 10 minutes.

On the front there are four bushings (**A+**, **A-**, **V+**, **V-**), two of which provide for the measuring current and two for the detection of the voltage drop across the resistor. The four-wire method makes it insensitive the measure from resistance of the wires that carry the current and the various contact resistances in the circuit *nanooammeter - test leads - unknown resistance*. The input signal is then amplified and compared with the reference internal resistance: the result, properly prepared and processed by a microprocessor, is shown on the LCD.

The low current used for the measurement reduced to the negligible power dissipation for Joule effect, with the consequent very low alteration of the measurement. For the same reason the fall of the maximum rated voltage of 32mV which avoids any semiconductor junctions in parallel to the unknown resistance make the measurement invalid.

With the exception of range $32\mu\Omega$, you can choose between two measurement currents. With the current "high" there is a resolution in $1\mu\text{V}$ voltage, which drops to $0.1\mu\text{V}$ with the current "low". If the necessity is to have a minimum dissipation on element under measurement, the choice is to use the lower current, evidenced by written **cur:** before the value of the current, in the lower part of the display. Otherwise it is recommended to use higher current, shown with the **CUR:** before the value of the current, so as to minimize side effects due to potential contact or drifts of the measuring amplifier. Important notices in this regard are given in the section **TIPS ON THE MEASUREMENT EXECUTION**.

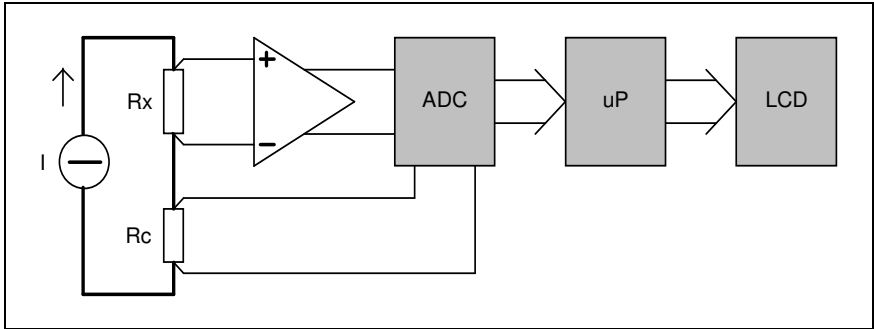

Fig. 1 Block diagram of the nanoohmmeter 20024 and the four-wire measurement.

CAUTION:

The presence of the sign "-" before the value of the measure is only to indicate that they exchanged the terminal voltage V^- with V^+ : this does not result dangerous to the instrument, but does not guarantee the validity of the measure because the amplifier is optimized for positive signs.

AUTO HOLD

The instrument has an Auto Hold function, ie the ability to "freeze" the display when the test leads or the pliers are disconnected from the element under test. In particular, this happens when you have the interruption of the circuit by disconnecting at least one of the current terminal.

It is given to reporting on the status line at the bottom right of the screen with the word **AHld** flashing.

CAUTION:

This function is automatically activated only when the instrument is in *Manual* mode. This allows you to maintain the auto-ranging function for automatic selection of the most suitable range to measure.

DEFINITION BUTTONS AND INPUTS

BUTTONS

The instrument has 12 buttons whose functions and modes of operation are detailed below and summarized in a table below. Through them you can directly select all the functionality of the instrument without resorting to menus or keystrokes.

Four buttons are dual function and the selection of the function is based on the time in which they are pressed: short if less than one second, or long if greater than said time.

The two functions refer to the same mode. As an example consider the **BIP** button. Pressing it briefly activates the bipolar measuring, while pressing for a long time allows you to get out it.

A suitable acoustic alert if the function, or the pressed button, is active or not. In certain conditions, in fact some buttons are disabled and pressing there is a long beep. An example is the inability to perform an auto-zeroing procedure during a bipolar measure. Pressing the **A/Z** button there is a long beep.

The following lists the buttons and their functions.



Selection of the upper range

If the instrument is in *Automatic* mode go to *Manual* mode.

If the instrument is in *Manual* mode selects the range immediately above, unless it has already been reached the range of 320Ω.

On the screen relative to the temperature compensation allows increasing this parameter.



Selection of the lower range

If the instrument is in *Automatic* mode go to *Manual* mode.

If the instrument is in *Manual* mode selects the range immediately below, unless it has already been reached the range 32μΩ.

On the screen relative to the temperature compensation allows the decrease of this parameter.



Automatic/Manual mode

If the instrument is in *Automatic* mode is brought into *Manual* mode and vice versa.

FUNC**Main measure****Multifunction button****Absolute and relative percentage****Setting the room temperature****Measurement with temperature compensation**

The button passes successively displaying of

- *main measure + bargraph*
- *main measure + bargraph + absolute and relative percentage*
- *setting the room temperature*
- *measurement with temperature compensation + main measure + room temperature*

each time you press the button.

main measure + bargraph + absolute and relative percentage

Pressing the button when are displayed only the main measure and the bargraph will displayed also the relative measure expressed as a percentage and absolute, both with sign.

The percentage value is calculated with the formula

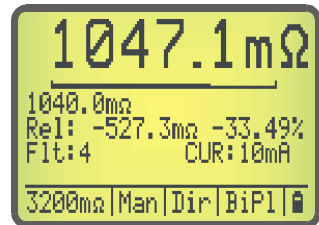

$$\text{percentage} = 100 * (\text{actual_value} - \text{initial_value}) / \text{initial_value}$$

where with the initial value and actual value are respectively indicated the value read from the instrument at a time when you pressed the button and the last acquired value, obtained from an average of readings equal to the value reported by **Flt**.

The minimum and maximum values represented are respectively -100.0% to +6550.0%. When the percentage value, in absolute terms, equals or exceeds 100% the resolution automatically changes from 0.01% to 0.1%.

In absolute representation you have the resolution of the range at that moment on, while the value is expressed as

$$\text{absolute} = \text{actuale_value} - \text{initial_value}$$

setting the room temperature

By pressing the button you have the disappearance of the main measure, of the bar graphs and relative measures, while displaying only the temperature compensation of the resistance, denoted by T_a , ie ambient temperature. This is because that temperature is that at which the measurement is taken of the unknown resistance.

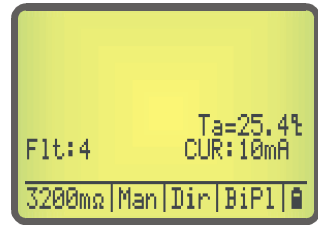

In this screen the temperature is varied using the buttons ▲ and ▼ respectively for increasing and decreasing the temperature value displayed on the right of the screen, with a resolution of 0.1°C in a range between 0.0°C and 50.0°C . The new value is automatically saved in non-volatile memory of the instrument when you switch to the measure compensated.

measurement with temperature compensation + main measure + room temperature

Pressing another once the button you have the representation of the compensated measurement (at the top), while in the central area is the actual measurement of the resistance, indicated by **Ra** and performed at room temperature, and the set room temperature **Ta**.

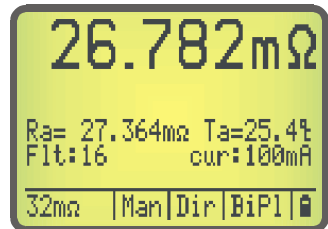

The compensated measure refers to a standard temperature of 20.0°C , according to CEI EN 60228:2005-10.

If you press the **CFG** button to save the configuration when you are on this screen, recalling the saved configuration or switching on the instrument is called this screen.

main measure + bargraph

Pressing the button disappears the screen with the compensated measure and appears the main measure and the bargraph.

If you press the **CFG** button to save the configuration when you are on this screen, recalling the saved configuration or switching on the instrument is called this screen.

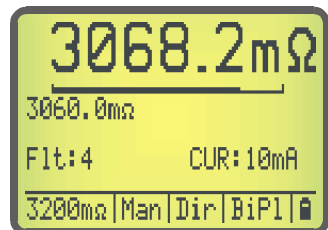

Interpretation of the operation of the bargraph

The bar graph under the main measure shows graphically the value between 1040.0mΩ and 1049.9mΩ. In the picture the bar graph is set to a value of 1040.0mΩ + 7.1mΩ (71 pixels).

The bar graph has a total of 100 "pixels" and graphically displays the small variations of the main measurement.

For example, if the primary measure is 264.15uΩ, the value to the left under the bar graph would be 264.00uΩ and the bar graph would be 15 pixels long (0,15uΩ).

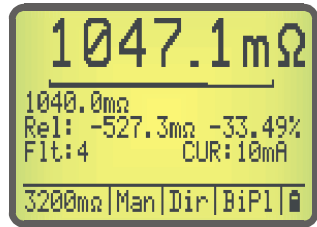
**Zeroing procedure****Multifunction button*****Button pressed < 1 sec Auto-zeroing***

This multifunction button allows the auto-zeroing the instrument without the need to disconnect the terminals of current or voltage and short circuit them. This procedure, on instruments of high sensitivity such as this, if not done properly could make it completely unreliable the measurement.

With the automatic procedure is also obtained compensation of the various thermoelectric effects in the contact points between the terminal voltage and the unknown resistance as well as all along the measuring cable up inside the instrument for each contact of different metal materials. During execution of auto-zeroing is obtained also the elimination of the drift of the measuring amplifier.

Pressing the button for less than 1 second appear the words **AUTOZERO** flashing and the bar timepiece until the completion of the procedure, the duration of which is variable depending on the number of readings to be performed to obtain the average, the value of which is set by **FLT** button.

Button pressed > 1 sec Lead current compensation

The second function of this button is activated if this is pressed over a second and allows to compensate the voltage drop on the current cables in a better way than does the procedure of auto-zeroing. In fact, despite the high common mode rejection of the input amplifier, when current cables have high voltage drop due to the measurement currents of 1 ÷ 10A, or the section of these is insufficient or they are too long, the amplifier is not able to fully compensate for the common mode voltage variation that it comes to have between the normal operating conditions (with the current circulating in the cables) and that of auto-zeroing (when current is interrupted momentarily).

Although specifically designed for the compensation described above, and then especially in the presence of measurement currents of 1A and 10A, this possibility is active on all ranges since also allows zeroing the measurement if it appears that, connected to the terminals as shown in Fig 2, the main measure is not of zero value.

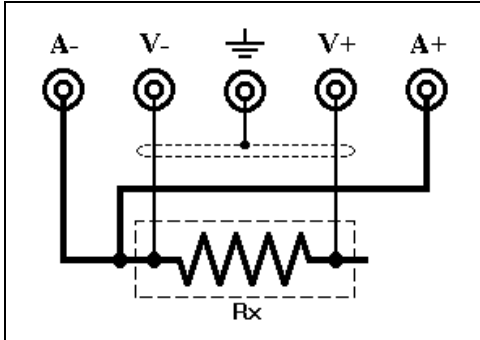

Fig. 2 Connection to be made during the compensation of the voltage drop on the current cables.

By its nature, the compensation is different for each range and depends on the measuring current used. Compensation is therefore only valid for the range and for the current measurement. For this reason the instrument saves the particular compensation in the memory cell corresponding to that range and the current, so as to recall it when they are selected again. The compensation is saved in non-volatile memory at power down. Since the saved values are highly dependent on the measurement conditions (length and cross-section of cable current, potential thermoelectric and internal temperature of instrument, as well as elapsed time from power on of the latter) it may happen that the next time you turn on the instrument the compensation is no longer valid.

CUR

Selecting the Current Measurement

Toggles the current measuring low or high.

The nominal current measurement is indicated by the word **cur:** or **CUR:** depending on whether low or high, respectively. For the range of $32\mu\Omega$, where the current is only 10A, the writing depends on the last selection made.

BIP

Procedure of Bipolar Measure

Multifunction button

Button pressed < 1 sec Activation bipolar measurement

Do not execute this command if the measure is overloaded.

If the instrument is performing the measurement with reverse current change it to direct current then wait for a time dependent on the number of readings to be performed to obtain the average, the value of which is set by pressing the **FLT** button.

The bipolar measurement procedure consist to run the number of measurements set by the **FLT** with the direct current and the same with the reverse current and perform the average, then returning in direct current mode. During the procedure appear the words **BIPOLAR** flashing and the bar timepiece. At the end of the procedure the measurement is displayed and flashes **BiPI** at the bottom of the screen. A further bipolar measurement can be started by pressing again the **BIP** button.

Button pressed > 1 sec *Deactivation bipolar measurement*

Pressing the button for longer than a second the instrument leaves the bipolar measurement mode and disappears BiPI written at the bottom of the screen.

FLT

Selecting Filter

Each time the button is pressed you select a different filter value in the sequence 1-2-4-8-16-32-64-1-2-4 - The number, which is also displayed at the bottom of the screen after the word **Flt:**, indicates the number of acquisitions used to calculate the average, which is the main measure represented.

This is particularly useful especially on the range of $32\mu\Omega$ or when using the measuring current low, where the instrument has a maximum sensitivity voltage. The greater the number of measurements over which the average is performed and more slowly responds the instrument. While maintaining a frequency of update of the measurement on the display of 5 Hertz, has the advantage of better stability of the representation.

It may happen that switching to a following filter value the main measure proves unreliable temporarily, until the buffer of the measures is refilled.

BKL

Backlight

Turns on/off the backlight of the display.

In case of battery operation it is recommended to turn on the backlight only when absolutely necessary since the power absorbed by the instrument, excluding the measuring current, increases from about 120mW to 700mW, reducing the operating time of the instrument considerably. The autonomy, however, does not fall below 50 hours with the backlight actived and range $3200m\Omega$ or higher.

POL**Measurement Mode Direct or Reverse**

If the instrument is in *Direct* mode is brought into *Reverse* mode and vice versa. Allows to determine the direction of the current in the element under test without having to disconnect the terminals to reconnect in the reverse way when a measurement is required with the opposite polarity or to assess the presence of electrical potentials of different nature in the circuit voltage. In fact it is not advisable to physically swap the terminals because it may determine different electrical potentials, thwarting the measurement made just to determine or to reduce the influence of such potential.

If possible you should use the higher current for execute the measure. In this way minimizes the influence of the potential of contact thanks to a signal voltage ten times greater.

CFG**Save Configuration****Multifunction button**

Button pressed < 1 sec **Recall saved configuration**

Pressing the button briefly is recall the saved configuration: range, filtering, current, automatic/manual, backlight and function displays: the main measurement or measure temperature compensated.

Button pressed > 1 sec **Save configuration**

Pressing the button for longer than a second you save the current configuration.

HOLD**"Freezing" of the measure**

Toggle on/off the hold mode of the measure.

During the *Hold* mode does not work any button, with the exception of the buttons backlight **BKL** and filter **FLT**.

If the instrument is in *hold* mode **Hold** text is displayed flashing in the status line at the bottom right of the screen.

In the table below are summarized the operation, the mode of activation and the type of signaling in function of time for which a button is pressed.

Name button	Action short/long	Operation	Acoustic warning short/long
▲	short	If in <i>Autorange</i> mode: Exit from auto-range, remaining in the selected range.	short
		If in <i>Manual</i> mode: If it has not reached the range of 320Ω passes to the upper range. Do not execute the command if it is on the range of 320Ω.	short long
		In the lower part of the screen appear the range activates and the text " Man ".	
▼	short	If in <i>Autorange</i> mode: Exit from auto-range, remaining in the selected range.	short
		If in <i>Manual</i> mode: If it has not reached the range of 32μΩ passes to the lower range. Do not execute the command if it is on the range of 32μΩ.	short long
		In the lower part of the screen appear the range activates and the text " Man ".	
AUTO	short	If in <i>Autorange</i> mode: Switch to <i>Manual</i> mode without changing the range.	short
		If in <i>Manual</i> mode: Switch to <i>Autorange</i> mode selecting the range that is suitable for measurement.	short
		In the lower part of the screen appear the range activates and the text " Aut ".	
FUNC	short	Having a complex operation, refer to section relative to the FUNC button to p. 5.	short
		Measurement of Relative Absolute has the same resolution as the main measure, while the measure of Relative Percentage has a resolution of 0.01% up to 99.99% and by 0.1% from 100.0% onwards.	
A/Z	short	Perform a auto-zeroing the instrument.	short
	long	If the measurement is in Overload: Do not execute the command	long
		If measurement <1000 points: Captures the value and treats it as zero.	short
	long	If measurement ≥1000 points: Do not execute the command.	long

CUR	short	If the measuring current is high and the range are from 320Ω to 320μΩ:	Switch to low current measurement.	short
		If the measuring current is low and the range are from 320Ω to 320μΩ:	Switch to high current measurement.	short
	long	If the range is 32μΩ (measuring current fixed to 10A):	Do not execute the command.	long
		The measuring current is indicated by the word "cur:" or "CUR:" depending on whether low or high, respectively. For the range of 32μΩ the word depends on the last setting made.		
BIP	short	If the measurement is in Overload:	Do not execute the command.	long
	long	If the measurement is valid:	Measurements are made using direct and reversed polarity and is represented the average. The measure goes on hold and you have the flashing of the word <i>BiPl</i> on the bottom screen.	short
long		Exits from <i>Bipolar</i> measurement.		short
FLT	short	Each time the button is pressed you select a different filter value in the sequence 1-2-4-8-16-32-64-1-2-4 -		short
BKL	short	Turns on/off the backlight of the display.		short
		Given the high consumption of the backlight is recommended, in case of battery operation, turning it on only when absolutely necessary.		
POL	short	Switch from direct to reverse polarity measurement and vice versa.		short
		At the bottom of the screen appears " <i>Dir</i> " or " <i>Inv</i> ".		
CFG	short	Recall the saved configuration (range, filtering, current, automatic/manual, measure compensated and backlight).		short
	long	Save the current configuration of the instrument.		short
HOLD	short	If the measurement is not in <i>Hold</i> :	Block the measure and you have the flashing of word <i>Hold</i> in bottom of the screen. Remain active only FLT , BKL and CFG buttons.	short
		If the measurement is in <i>Hold</i> :	Exits from block of the measure.	short

INPUTS

On the front panel there are only four test sockets, which are essential if you want to measure resistances of low and very low value with the Kelvin method.

A+ / A-

Current Terminals

These terminals provide the measuring current. With the current circuit open the voltage present at the output is between 2V and 2.4V, depending on the state of the battery and the presence or absence of the mains voltage.

V+ / V-

Voltage Terminals

Through these terminals is detected the voltage drop across the unknown resistor, with a sensitivity that reaches 10nV on the range of 32μΩ.

GND

Ground Terminal

Located at the rear of the instrument is a standard bushing with hole 4mm in diameter electrically connected to the housing. Can be used to improve the rejection to environmental disturbance by connecting the instrument to the ground.

Alternatively or in combination the same bushing can be used to connect a shield of voltage cable, as shown in Fig 2 or Fig 3 on page 7 to page 18.

LINE

Power Socket

Located at the rear of the instrument is the power plug from the mains 230V ± 10% 48-66Hz and 5x20mm fuse holder with fuse 200mA delayed.

COM

Communication Port

Located at the rear of the instrument allows to communicate with a PC via an optically isolated connection. You can read the data and setup of the instrument and modify the setup.

AUXILIARY INFORMATIONS

In the five areas of the lower part of the display the status line provides many auxiliary information summarized in the table below.

Sector	Information	Indication	Note	Status of the message
1	Range	320Ω 32Ω 3200mΩ 320mΩ 32mΩ 3200μΩ 320μΩ 32μΩ	Selected range	Permanent on all ranges
2	Automatic / Manual	Aut Man	Instrument in <i>Autorange</i> mode Instrument in <i>Manual</i> mode	Permanent
3	Direct / Reverse	Dir Inv	The current flows from the positive terminal The current flows from the negative terminal	Permanent
4	Bipolar Hold	BiPl Hold AHld no indication	The instrument is performing a bipolar measure Instrument is in <i>Hold</i> mode Instrument is in <i>Auto Hold</i> mode The instrument is not in <i>Hold</i> or <i>Auto Hold</i> mode and even in bipolar measuring	Flashing Flashing Flashing
5	Battery status	no indication image of a battery with charge level gradually decreasing image of empty flashing battery	Battery OK Battery charge level in gradually decreasing Fully discharged battery	Permanent Flashing

TECHNICAL SPECIFICATIONS

Power supply	230V \pm 10% 48-66Hz fuse 200mA delayed
Power requirement	15VA
Battery	visual indication of charge status battery
Battery autonomy	view Tab. 2
Representation	on backlighted graphic display 64x128 pixels 62x44mm
Points of measure	32000
Display refresh rate	5 Hz
Range	32,000 $\mu\Omega$, 320,00 $\mu\Omega$, 3200,0 $\mu\Omega$, 32,000m Ω , 320,00m Ω , 3200,0m Ω , 32,000 Ω , 320,00 Ω
Range selection	automatic / manual
Automatic change of scale	switch to range higher >31999 points switch to range lower <3000 points
Resolution and measuring current	view Tab. 1 RESOLUTION AND MEASURING CURRENT
Measurement accuracy (@ 20°C) (range 320 Ω \div 3200 $\mu\Omega$ high current)	\pm (0,05% + 0,001%/°C + 2 digit)
Measurement accuracy (@ 20°C) (range 320 Ω \div 3200 $\mu\Omega$ low current)	\pm (0,06% + 0,001%/°C + 3 digit)
Measurement accuracy (@ 20°C) (range 320 $\mu\Omega$ high current)	\pm (0,06% + 0,001%/°C + 3 digit)
Measurement accuracy (@ 20°C) (range 320 $\mu\Omega$ low current)	\pm (0,07% + 0,001%/°C + 5 digit)
Measurement accuracy (@ 20°C) (range 32 $\mu\Omega$)	\pm (0,07% + 0,001%/°C + 5 digit)
Noise (referred to input from 0,01Hz to 0,1Hz)	200nV _{pp} with filter = 16 (FLT = 16)
Compensation current cable / Zeroing	compensation of emf of voltage circuit and the offset of the instrument up to \pm 1000 digits
Heating time after the power up	about 15 minutes within a tolerance of \pm 0,3 μ V
Compensation range of the measure with the room temperature (Ta)	0,0°C a 50,0°C in steps of 0,1°C
Coefficient of temperature compensation	copper, according to standard CEI EN 60228:2005-10
Temperature at which the measurement is reported	20,0°C (according to standard CEI EN 60228:2005-10)
Open circuit voltage (A+) - (A-) (current circuit open)	2,20 Vmax (battery operation) 2,40 Vmax (mains operation)
Filter	average on 1, 2, 4, 8, 16, 32, 64 measures
Maximum inductive value	35 Henry / 150 ohm
Working temperature	0 \div 50 °C
Storage temperature	-20 \div 60 °C
Weight	4770 gr. approximately
Dimension	243x89x285mm (W x H x D)

The table below shows the values of resolution, measuring current and maximum power dissipated by the unknown resistance depending on the selected full scale.

RESOLUTION AND MEASURING CURRENT					
Range	Resolution (resistance)	Resolution (voltage)	Voltage of f.s.	Current (low/high)	Maximum power
32μΩ	1nΩ (10 ⁻⁹ Ω)	10nV	320μV	10A	3,2mW
320μΩ	10nΩ (10 ⁻⁸ Ω)	10/100nV	0,32/3,2mV	1/10A	320μW/32mW
3200μΩ	100nΩ (10 ⁻⁷ Ω)	0,1/1μV	3,2/32mV	1/10A	3,2/320mW
32mΩ	1μΩ (10 ⁻⁶ Ω)	0,1/1μV	3,2/32mV	0,1/1A	0,32/32 mW
320mΩ	10μΩ (10 ⁻⁵ Ω)	0,1/1μV	3,2/32mV	10/100mA	32μW/3,2mW
3200mΩ	100μΩ (10 ⁻⁴ Ω)	0,1/1μV	3,2/32mV	1/10mA	3,2/320μW
32Ω	1mΩ (10 ⁻³ Ω)	0,1/1μV	3,2/32mV	0,1/1mA	0,32/32μW
320Ω	10mΩ (10 ⁻² Ω)	0,1/1μV	3,2/32mV	10/100μA	32nW/3,2μW

Tab. 1 Summary table of the resolutions, sensitivity, measuring current and maximum power dissipation of the unknown resistance as a function of the selected range.

To prevent which excessive heating inside of the instrument may cause drifts in the measure, particularly so on the two lower ranges and when is used a high measurement current, the battery charge current is about 1A when the instrument is turned on and 2A current when it is off. Consequently, the full charge when switched off involves approximately 20 hours of time, while if the instrument is on and always working with measuring current, the charging time can vary greatly depending on the selected range and the state of the backlight. For measuring current of 1A and backlight on you have a slight discharge of the battery which, if the measured current increases to 10A, is discharged about in one hour.

The following is the graph of autonomy of the battery as a function of the selected range and the switching on/off the backlight of the display.

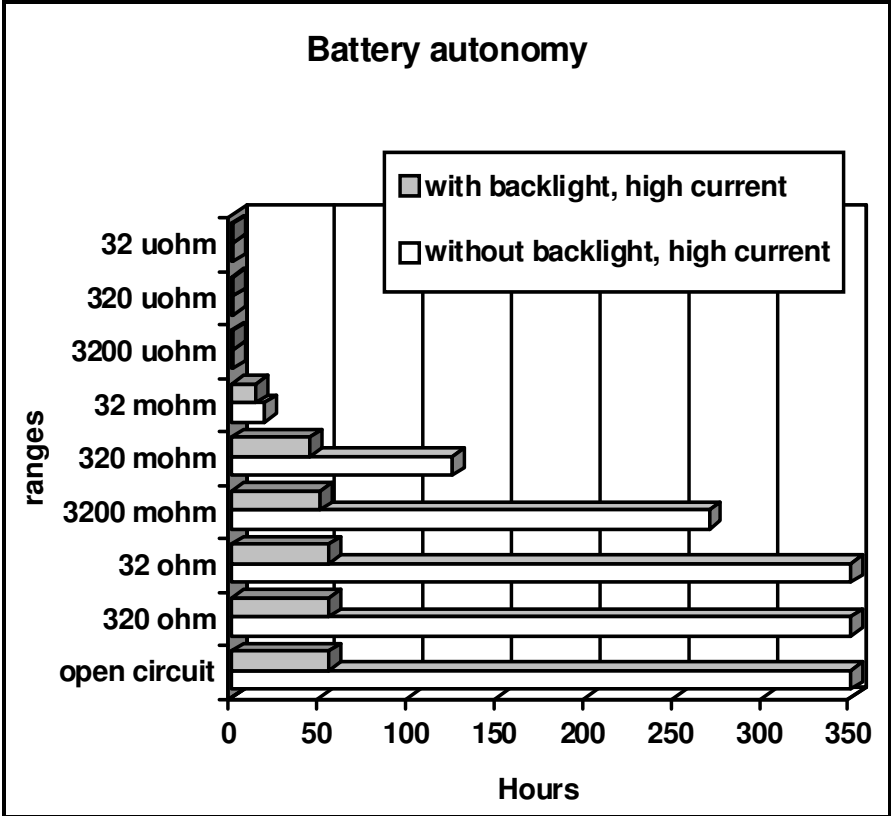

Tab. 2 Graph representing the autonomy of battery as a function the selected range and status of the backlight.

TIPS ON THE MEASUREMENT EXECUTION

POTENTIALS OF CONTACT

After switching on the instrument, before taking any measurements, it would be advisable to wait at least 10 minutes. This allows the necessary thermal settling of the components of the nanoohmmeter.

In carrying out the measure is essential, in order to obtain the best results, follow the connection diagram of the terminals of measurement shown in Fig 3. In this way it is avoided that in the circuit voltage there are the contact resistances of the current terminals, with a macroscopic alteration of the measurement results.

With cables of Kelvin type this problem does not exist since the two tweezers placed to end are connected in such a way as to avoid that the contact resistances adversely affect the measurement.

Other sources of error may be the potential of contact that you have when two different metal materials meet.

To minimize the influence of this physical phenomenon, it must try to have the same type of contact between positive and negative terminal voltage and the unknown resistance. This contemplates both the state of the surfaces (polished, oxidized, dirty, etc..) that the material (other than material of a head of the unknown resistance compared to another), as well as the different temperature at which they can be the points of contact of the element under test.

If the type of contact to the positive terminal is similar to the negative terminal, the two effects tend to cancel and at most remains a potential equal to the difference of the two. If this effect remains constant over time is sufficient to compensate him once and for all, on the contrary should be periodically reset by pressing A/Z button.

The change that you mention is mainly due to variations in temperature between the two points where the voltage probes touch the unknown resistance: the only way to get a stable and reliable measure is to take every

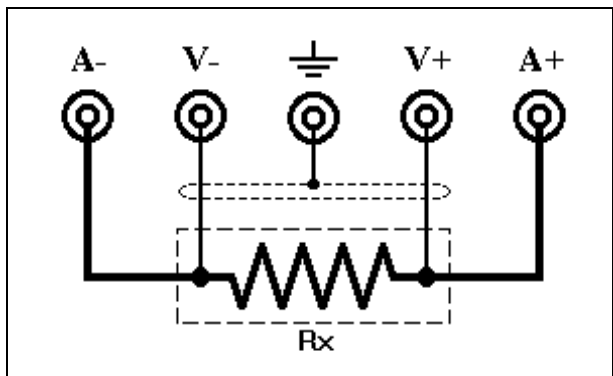

Fig. 3 Connection diagram for measuring four wires of a resistor of low value.

precaution to ensure that immediately after an zeroing there are not fluctuations in the temperature difference of the two points of contact.

All the above said phenomena are, in absolute value, certainly modest (generally a few tenths of microvolts), but unfortunately they are more than detectable by instruments of similar sensitivity. That's why it is essential to take some basic and essential precautions to have a good quality of the measurement. The main, but not the only ones, are:

- Clean the surfaces of the terminals of the unknown resistance and measuring cables from oil, water, oxides etc.
- If the section of the current cables is less than or equal to 4mm² these must be of equal cross section, to avoid that a different heating by Joule effect causes a drift of the measurement over time. In any case, it is strongly recommended that you use cables of not less than 6mm² when using the lower ranges of 3200μΩ, 320μΩ and 32μΩ.
- Wait for the cooling of the object to be measured.
- Avoid heating/cooling, even slightly and in whatever way, a terminal of the resistor to be measured relative to each other.
- Avoid concatenate the measurement cables with varying magnetic fields that can cause a bad reading.
- Always perform an auto-zeroing and possibly a compensation of test lead to the first measure, and wait at least 10 minutes after the power on before you use the instrument, if you want good accuracy and stability of the measurement.
- Always perform an auto-zeroing when you are on the range 3200μΩ, 320μΩ e 32μΩ or the test leads are connected to another resistance.
- Do not change the measurement point after you have performed a auto-zeroing.

Since the potential of contact may vary from point to point is essential, to have the best results, do not move the points of measurement, even if these are assumed to be equipotential: current flows and potential of contact different in different points alter the measure . This is absolutely valid also if you wanted to run an auto-zeroing: do not ever alter the electrical connection of the terminal voltage between measurement and the auto-zeroing.

USING THE METHOD OF BIPOLAR MEASURING

When it is assumed the presence of potential of contact not symmetric on the input terminals, which thus can not be eliminated by a simple auto-zeroing procedure, the solution is the use of the bipolar measurement mode. Since for each representation there are more measurements with direct and reverse current and a subsequent stop, this measurement system is inherently very slow and therefore is to be used only when needed or for actually to verify that there are asymmetric potentials comparing the result of a bipolar measurement (which in theory is the correct one) with the measurement available after a auto-zeroing.

Do not forget, however, that a difference of a few digits is possible and normal. Is not expected, therefore, also in case of absence of potential of contact or when these are symmetrical, a perfect identity of values.

Since the asymmetry of the potentials of contact is usually due to different causes, their drift or noise may be different. This can lead to a variation in time of the measurement more pronounced compared to the measurement with symmetric potentials of contact, which by definition they cancel each other. If there is an asymmetry in the potentials of contact, but you continue to use the normal measurement mode (not bipolar), it should be noted that the correction (zeroing) which is made may not be constant over time. Also considering a asymmetric noise of amplitude and causes different, therefore more difficult avoidable mutually, we recommend using a filter of at least 16 when you run a bipolar measuring: it helps to further reduce the variations in the measurement results.

As can be activated/deactivated has already been explained in the section on **BIP** button.

MEASUREMENT ON RANGE $32\mu\Omega$ AND $320\mu\Omega$ LOW CURRENT

Given that these two ranges have a sensitivity in voltage of only 10nV (equal to about 1/1000 of the signal provided by a thermocouple for a change of temperature of 1°C), its use must be entrusted to experienced personnel, capable of evaluating the multiple phenomena that may incur in making unreliable the measurement. It is necessary to be considered very carefully the temperature gradients in both environment and on the resistance being measured. You must choose appropriate connection points to the object under test by checking the mechanical strength, avoid in any way air flows, partial lighting power (which induce localized heating), magnetic fields, etc..

It is absolutely advisable to execute the measurement not less than 15 minutes after switching on the instrument: this allows to achieve an appropriate balance of thermal components of the instrument itself.

At this point there are two possible strategies of measurement that exploit respectively the thermal inertia and the thermal settling of the components. Indeed the passage of a measuring current of 10A determines a heating and consequent unwanted thermal drift due to thermal phenomena, however, that propagate and derive rather slowly, stabilizing at about 15 ÷ 20 minutes.

Having the possibility of perform a fast measurement is possible to exploit the thermal inertia, so as not to give rise to a sufficient heat propagation.

If is required instead a measurement in time you will have to wait for the thermal settling to have enough stability.

Please note that thermal drift can be as $\pm 0,3\mu\text{V}$ (equal to ± 30 digits) with a variation of about 0.5 to 1.5nV/sec, and it is normal to have variations, including noise, settling thermal and potential for contact, 100 to 200 digits.

A possible arrangement, to minimize the drift and the settling time, is to reduce the dissipation of the instrument making it run only on batteries, obviously after having loaded well in advance.

Avoid any case to circulate cooling air that surely would create differences and thermal variations on the cables of voltage measurement that would cause many signal variations.

Should not be underestimated even the noise both environmental and internal to the instrument. The latter is typically contained in approximately $\pm 200\text{nV}$ in a period of 1 minute. To reduce the variations in the short term it is recommended to use a filtering high: 32 or 64. In any case, the minimum filtering, on $320\mu\Omega$ and $32\mu\Omega$, is 8.

As regards the electromagnetic noise could perform the measurement in a Faraday cage or anechoic, connecting the instrument to the earth through the appropriate rear bushing, bearing the closer together the tension cables, to minimize the area, and the noise induced, within the coil of the signal.

If all this seems excessive, please note that measurements with resolutions of $1\text{n}\Omega$ are definitely very close measurable limits. Substantially below the $0,1\text{n}\Omega$ no longer able to go down. It is also recommended to put adequate attention to the measurement with "low" current (allowed in all ranges except $32\mu\Omega$) where the resolution of the output voltage is only $0,1\mu\text{V}$, definitely value to be considered low-level.

ELECTROMAGNETIC FIELDS

Other causes of instability or failure of the measurement or in zeroing are attributable to the presence of magnetic fields can induce electrical noise can move the level in DC of the signal. The best way to mitigate this influence is to keep short the wires of the voltage and current and that are not wobbly or vibrate

even in proximity to static magnetic fields: this will cause the occurrence of induced voltages of amplitude and frequency dependent on the movement.

CURRENT CABLES OF INSUFFICIENT SECTION

Another cause of error, even if in this case decidedly modest and found only on the ranges from $3200\mu\Omega$, $320\mu\Omega$ and $32\mu\Omega$, is due to the limited section of the current leads. If in fact the section is less than 6 mm^2 and the cable is proportionally too long it has, between zeroing and measurement, a difference in the voltage drop on the cable that the measuring amplifier is no longer able to properly compensate, by introducing a error, with the cables supplied, usually not more than 2 to 4 digits. The remedy is to use, on the lower range, cables of elevated section and as short as possible.

If there is any cables that provide high falls and compensation is necessary to reduce the error, see the instructions on page 7 relating to paragraph **Zeroing procedure**.

SLOW OF MEASUREMENT

This is certainly not a cause of the error, but it may seem, sometimes, that the instrument is too slow or even stop it: the reason is due to the value that has been set in the filter. The higher this value, the longer the time that the instrument takes to make a series of measurements on the unknown resistance.

MEASUREMENT OF ELEMENTS HIGHLY INDUCTIVE

The nanoohmmeter **20024** is able to measure the resistive component also highly inductive elements such as transformers with a power of more than 1 MVA. To avoid damage or malfunction of the instrument is advisable to connect, in parallel to the unknown resistance, a diode as shown in Fig 4, the next page.

Such protection diode should however put only if actually there is a need and in the presence of inductive loads, since on high range the reverse current of the same diode can alter, although modestly, the measurement.

To protect the range from 320Ω to $320\text{m}\Omega$ including is sufficient a diode of the type 1N4004 or similar, able to withstand currents of 1A. For the lower range (from $32\text{m}\Omega$ to $32\mu\Omega$) is advisable to use a diode can withstand higher currents.

Its function is mainly to protect the amperometric circuit. The voltage circuit is protected against continuous differential voltages up to $\pm 35\text{V}$ and pulse up to $\pm 100\text{V}$ for 1 second.

CAUTION:

The instrument is not able to bear, on the bushings of measurement, the application of external voltages or currents, especially if due to the direct connection with the network line.

PROTECTION FROM OVERVOLTAGE AND OVERCURRENT

The instrument is provided with adequate protection against voltage surges on voltage inputs, as specified in the technical specifications, but requires, in the case of measurement of predominantly inductive elements, an external protective diode. Such a diode as shown in the previous section, is fully sufficient to protect the generator current circuit. This does not mean, however, that the instrument is able to withstand electrical stress such as connection to motors or transformers connected to its power supply, especially if this is the line network. The electric power at stake in this case would be well beyond those tolerable by the protection circuitry, internal and external, of nanoohmmeter and its damage would be certain.

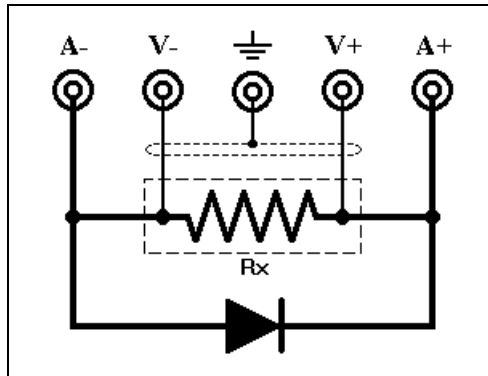

Fig. 4 Connection diagram of the protection diode in parallel with an strongly inductive element. Note the direction of insertion of the diode.

CAUTION:

It is important that the protective diode is connected in parallel to inductive element and not between the terminals of current or voltage, otherwise it is not able, disconnecting current cables, to eliminate the strong glitter that is created. The spark can also reach voltages of thousands of volts and irreparably damage some electronic circuits of the current generator.

COMMUNICATION PORT

GENERALITY

The nanoohmmeter **20024** is equipped as standard with a USB interface optically isolated. Using the appropriate optional module, which looks similar to a plug connector RS232 9 pin, you can connect the device to a PC to obtain the following information:

- ▶ *main measure*
- ▶ *relative measure*
- ▶ *measure temperature compensated*
- ▶ *room temperature for the compensation of the measurement*
- ▶ *instrument status (range, filter, page view, current measurement, backlight, etc.).*

Also you can:

- ▶ *set the room temperature for measure compensation*
- ▶ *change the setup of the instrument*

All of this means of just two commands:

- *a read request with which the instrument provides all the information available to it by sending a string of 13 bytes followed by a fourteenth byte of checksum*
- *a write command followed by a string of 5 bytes that represent the new setup, to which is added a seventh byte of checksum*

READING DATA

Is sent to a single request bytes of 00H value. The instrument complies with 13 bytes of data followed by a checksum byte terminal, as shown in the following table. The first 5 bytes are both read and write, or are bytes to be sent to the instrument when requesting any changes to the setup. More details will be given in section **WRITING SETUP**.

Some data in the form of bytes (range, filtering, and serial number), others in the form of words as a set of two bytes (the main measurement, relative measurement, compensated measurement and room temperature for compensation), and still others as a set of flags with fields of one or two bits.

READ COMMAND = 00H			
# byte	Definition	Type of data	Read / Write
1	upper byte of room temperature compensation	word	read and write
2	lower byte of room temperature compensation		
3	range	byte	read and write
4	filter	byte	read and write
5	status1	flag	read and write
6	status2	flag	read
7	upper byte of main measure (absolute value)	word	read
8	lower byte of main measure (absolute value)		
9	upper byte of relative value (absolute value)	word	read
10	lower byte of relative value (absolute value)		
11	upper byte of temperature compensated measure	word	read
12	lower byte of temperature compensated measure		
13	serial number instrument	byte	read
14	checksum	byte	read

Below will be explained in detail how to interpret the data received.

byte 1-2 Room temperature of compensation

Represents the value of the temperature used to compensate the measurement and is expressed without a decimal point or, equivalently, in tenths of a degree: if the ambient temperature is set to of 27.4°C the value is equal to 274.

To obtain the value, perform this calculation:

$$\text{temperature_value} = \text{byte1} * 256 + \text{byte2}$$

Is a value both read and write access.

byte 3 Range

This byte contains a code corresponding to the selected range, as indicated in the table opposite.

Is a variable both read and write.

RANGE	
Code	Range
0	32μΩ
1	320μΩ
2	3200μΩ
3	32mΩ
4	320mΩ
5	3200mΩ
6	32Ω
7	320Ω

byte 4 Filter

This byte contains a code corresponding to the selected filter, as indicated in the table opposite.

Is a variable both read and write.

FILTER	
Code	Filter
0	1
1	2
2	4
3	8
4	16
5	32
6	64

byte 5 Status1

This byte is a set of seven fields where is summarized the state of the instrument.

Is a variable both read and write.

Status1			
# bit	Binary weight	Meaning	Value
0	1	Measure represented	0 = main measure + bargraph
1	2		1 = main measure + bargraph + absolute and relative percentage 2 = setting room temperature 3 = measurement with temperature compensation + main measure + room temperature
2	-	Measuring current	0 = low current 1 = high current
3	-	Backlight display	0 = off 1 = on
4	-	Measurement direct/reverse	0 = measured by direct current 1 = measured by reverse current
5	-	Select range manual/automatic	0 = manual 1 = automatic
6	-	Measurement active/in hold	0 = active 1 = in hold
7	-	Measurement active/in zeroing	0 = active 1 = in zeroing

byte 6 Status2

This byte is a set of 6 fields which complement the state of the instrument.
Is a read-only variable.

Status2			
# bit	Binary weight	Meaning	Value
0	1	Bipolar measurement	0 = measurement not bipolar
1	2		1 = bipolar measurement 2 = bipolar measurement in hold 3 = <i>not used</i>
2	1	Overload measurement	0 = no overload
3	2		1 = positive overload 2 = negative overload 3 = <i>not used</i>
4	-	Sign of the main measurement	0 = positive polarity (+) 1 = negative polarity (-)
5	-	Sign of the relative measurement	0 = positive polarity (+) 1 = negative polarity (-)
6	-	<i>not used</i>	
7	-	<i>not used</i>	

byte 7-8 Main measure

Represents the absolute value of the main measure and is expressed without commas or units. The correct representation is determined by considering the selected range and bit 4 of *State2*.

If a hypothetical measure is 217,43 mΩ (range code = 4), the value contained in the two bytes considered is of 21743.

To obtain the value, perform this calculation:

$$\text{main_measure_value} = \text{byte7} * 256 + \text{byte8} \quad (\text{absolute value})$$

Is a read-only variable.

byte 9-10 Relative measure

Represents the absolute value of the relative measure and is expressed without commas or units. The correct representation is determined by considering the selected range and bit 5 di *Stato2*.

If a hypothetical measure is -1,09μΩ (range code = 1), the value contained in the two bytes considered is of 109.

To obtain the value, perform this calculation:

$$\text{relative_measure_value} = \text{byte9} * 256 + \text{byte10} \quad (\text{absolute value})$$

Is a read-only variable.

byte 11-12 Room temperature of compensation

Represents the value of the room temperature used to compensate the measurement and is expressed without comma or units of measure. The correct representation is determined by considering the selected range and bit 4 of State2.

If a hypothetical measurement is 1698,2μΩ (range code = 2), the value contained in the two bytes considered is of 16982.

To obtain the value, perform this calculation:

$$\text{temperature_compensated_measure_value} = \text{byte11} * 256 + \text{byte12} \text{ (absolute value)}$$

Is a read-only variable.

byte 13 Serial number

Is the instrument serial number.

Is a read-only variable.

byte 14 Checksum

Is the algebraical sum of thirteen bytes of data, truncated to the lower byte.

If hypothetically the sum of the byte corresponds to 07A2H (07A2 value in hexadecimal notation) this byte is A2H.

Is a read-only variable.

WRITING SETUP

The whole setup of the instrument is written at one time by sending the command byte 08H, following it by the same first five bytes received while reading, amended as necessary to reflect the new desired setup.

It is reiterated that, regardless of how many and which bytes have been modified, is absolutely indispensable send all five bytes represented in the table below after the command byte 08H adding, as the seventh and last byte, the checksum byte.

You should definitely consider when you want to change the setup, first perform a read, so you have the updated position at the last moment of the state and of the setup of the instrument.

WRITE COMMAND = 08H			
# byte	Definition	Type of data	Read / Write
1	08H (command code for writing)	byte	write
2	upper byte of room temperature compensation	word	read and write
3	lower byte of room temperature compensation		
4	range	byte	read and write
5	filter	byte	read and write
6	state1	flag	read and write
7	checksum	byte	write

Below you will specify in detail how to interpret the data to send.

byte 1 Write command

Is a constant value of 08H..

byte 2-3 Room temperature of compensation

It has exactly the same meaning and modes of representation indicated in the section on reading data.

The validity range of the value is between 0 and 500, inclusive. Values that exceed these limits are not considered by the instrument.

Suppose you want to send a value to an room temperature of 31.2°C, it is necessary to consider the value 312 which, in hexadecimal, is represented as 0138H, namely:

byte2 = 01H

byte3 = 38H

byte 4 Range

It has exactly the same meaning and modes of representation shown in the table on the range.

The validity range of the value is between 0 and 7, inclusive. Values that exceed these limits are not considered by the instrument.

If the new range is different from the previous, the instrument is forced into manual mode and exits from eventual representation of the relative measure, displaying only the main measure + bar graph.

byte 5 Filter

It has exactly the same meaning and modes of representation shown in the table for the filter.

The validity range of the value is between 0 and 6, inclusive. Values that exceed these limits are not considered by the instrument.

On two lower range ($320\mu\Omega$ and $32\mu\Omega$) any codes of filter less than 3 are forced to 3, to ensure that an adequate filtering of measurements in the presence of noise.

byte 6 State1

Being a set of flags each bit can be changed independently of any other.

State1			
# bit	Binary weight	Meaning	Value
0	1	Measure represented	0 = main measure + bargraph
1	2		1 = main measure + bargraph + absolute and relative percentage 2 = setting room temperature 3 = measurement with temperature compensation + main measure + room temperature
2	-	Measuring current	0 = low current 1 = high current
3	-	Backlight display	0 = off 1 = on
4	-	Measurement direct/reverse	0 = measured by direct current 1 = measured by reverse current
5	-	Select range manual/automatic	0 = manual 1 = automatic
6	-	Measurement active/in hold	0 = no request 1 = are asked to hold the measure
7	-	Measurement active/in zeroing	0 = no request 1 = asked the zeroing of the instrument

byte 7 Checksum

Is the sum of the six bytes of data (including command byte), truncated to the lower byte.

If hypothetically the sum of the previous byte corresponds to 02FBH (02FB value in hexadecimal notation) this byte is FBH.

TEST CERTIFICATE

INSTRUMENT MODEL **20024**
SERIAL NUMBER INSTRUMENT _____
BATTERY **OK**
USB PORT **OK**
TEMPERATURE of CALIBRATION _____

RANGE	RESISTANCE OF REFERENCE	MEASURED VALUE	PRECISION DECLARED (high/low current)	RESULT
320Ω			0,5 ‰ / 0,6 ‰	OK
32Ω			0,5 ‰ / 0,6 ‰	OK
3200mΩ			0,5 ‰ / 0,6 ‰	OK
320mΩ			0,5 ‰ / 0,6 ‰	OK
32mΩ			0,5 ‰ / 0,6 ‰	OK
3200μΩ			0,5 ‰ / 0,6 ‰	OK
320μΩ			0,6 ‰ / 0,7 ‰	OK
32μΩ			0,7 ‰	OK

TEST NOISE **OK**
TEST EMC **OK**
TEST BURN-IN **OK**
MANUAL, CABLES, SOFTWARE **OK**

This is to certify that the instrument conforms to the technical specifications relating thereto, as stated in the technical specifications.

Date _____ The Verifier _____ The Operator _____

DECLARATION OF CONFORMITY

The company PEDRANTI ELIO, Via Cesare Battisti 33/B, Cardano al Campo - Varese, Italia, declare under our sole responsibility that the instrument **20024**, to which this declaration relates, is in conformity with the rules laid down in directive CEE89/336.

Cardano al Campo, 07/07/08

. Pedranti Elio .