

# Kinetix 350 Single-axis EtherNet/IP Servo Drives

Catalog Numbers 2097-V31PR0-LM, 2097-V31PR2-LM, 2097-V32PR0-LM, 2097-V32PR2-LM, 2097-V32PR4-LM, 2097-V33PR1-LM, 2097-V33PR3-LM, 2097-V33PR5-LM, 2097-V33PR6-LM, 2097-V34PR3-LM, 2097-V34PR5-LM, 2097-V34PR6-LM

Topic	Page
About the Kinetix 350 Drives	1
Important User Information	2
Catalog Number Explanation	3
Before You Begin	4
Install the Kinetix 350 Drive	4
Connector Data	7
Power Wiring Requirements	11
Motor Overload Protection	15
Additional Resources	16

## About the Kinetix 350 Drives

Kinetix® 350 single-axis EtherNet/IP servo drives provide an Ethernet-enabled solution for applications with output power requirements in the range of 0.4...3.0 kW (2...12 A rms).

Refer to the Kinetix 350 Single-axis EtherNet/IP Servo Drives User Manual, publication [2097-UM002](#), for detailed information on wiring, applying power, troubleshooting, and integration with ControlLogix® or CompactLogix™ controller platforms.

## Important User Information

Read this document and the documents listed in the additional resources section about installation, configuration, and operation of this equipment before you install, configure, operate, or maintain this product. Users are required to familiarize themselves with installation and wiring instructions in addition to requirements of all applicable codes, laws, and standards.

Activities including installation, adjustments, putting into service, use, assembly, disassembly, and maintenance are required to be carried out by suitably trained personnel in accordance with applicable code of practice.

If this equipment is used in a manner not specified by the manufacturer, the protection provided by the equipment may be impaired.

In no event will Rockwell Automation, Inc. be responsible or liable for indirect or consequential damages resulting from the use or application of this equipment.

The examples and diagrams in this manual are included solely for illustrative purposes. Because of the many variables and requirements associated with any particular installation, Rockwell Automation, Inc. cannot assume responsibility or liability for actual use based on the examples and diagrams.

No patent liability is assumed by Rockwell Automation, Inc. with respect to use of information, circuits, equipment, or software described in this manual.

Reproduction of the contents of this manual, in whole or in part, without written permission of Rockwell Automation, Inc., is prohibited.

Throughout this manual, when necessary, we use notes to make you aware of safety considerations.

---



**WARNING:** Identifies information about practices or circumstances that can cause an explosion in a hazardous environment, which may lead to personal injury or death, property damage, or economic loss.

---



**ATTENTION:** Identifies information about practices or circumstances that can lead to personal injury or death, property damage, or economic loss. Attentions help you identify a hazard, avoid a hazard, and recognize the consequence.

---

**IMPORTANT** Identifies information that is critical for successful application and understanding of the product.

---

Labels may also be on or inside the equipment to provide specific precautions.

---



**SHOCK HAZARD:** Labels may be on or inside the equipment, for example, a drive or motor, to alert people that dangerous voltage may be present.

---



**BURN HAZARD:** Labels may be on or inside the equipment, for example, a drive or motor, to alert people that surfaces may reach dangerous temperatures.

---

**ARC FLASH HAZARD:** Labels may be on or inside the equipment, for example, a motor control center, to alert people to potential Arc Flash. Arc Flash will cause severe injury or death. Wear proper Personal Protective Equipment (PPE). Follow ALL Regulatory requirements for safe work practices and for Personal Protective Equipment (PPE).

---

## Catalog Number Explanation

This publication applies to the following Kinetix 350 drives.

### Kinetix 350 Drives (single-phase)

Cat. No.	Input Voltage	Continuous Output Current A (0-pk)	Features
2097-V31PR0-LM	120/240V, 1 $\emptyset$	2.8	<ul style="list-style-type: none"> <li>120V Doubler mode</li> <li>Safe torque-off</li> </ul>
2097-V31PR2-LM		5.7	
2097-V32PR0-LM	240V, 1 $\emptyset$	2.8	<ul style="list-style-type: none"> <li>Integrated AC line filter</li> <li>Safe torque-off</li> </ul>
2097-V32PR2-LM		5.7	
2097-V32PR4-LM		11.3	

### Kinetix 350 Drives (single- or three-phase)

Cat. No.	Input Voltage	Continuous Output Current A (0-pk)	Features
2097-V33PR1-LM	120V, 1 $\emptyset$ 240V, 1 $\emptyset$ 240V, 3 $\emptyset$	2.8	Safe torque-off
2097-V33PR3-LM		5.7	
2097-V33PR5-LM		11.3	
2097-V33PR6-LM		17.0	

### Kinetix 350 Drives (three-phase)

Cat. No.	Input Voltage	Continuous Output Current A (0-pk)	Features
2097-V34PR3-LM	480V, 3 $\emptyset$	2.8	Safe torque-off
2097-V34PR5-LM		5.7	
2097-V34PR6-LM		8.5	

## Before You Begin

Remove all packing material, wedges, and braces from within and around the components. After unpacking, check the item nameplate catalog number against the purchase order.

### Parts List

The Kinetix 350 drive ships with the following:

- General-purpose power input (IPD) header, back-up power (BP) header, shunt resistor and DC bus (BC) header, motor power (MP) header, and safe-torque-off (STO) header
- A ground clamp that also provides strain relief for motor power cable
- These installation instructions, publication 2097-IN008

#### TIP

The connector kit for motor feedback (catalog number 2090-K2CK-D15M) is not provided. Replacement connector sets (catalog number 2097-CONN1) are also available.

Refer to the Kinetix Motion Accessories Specifications Technical Data, publication [GMC-TD004](#), for more information.

## Install the Kinetix 350 Drive

These procedures assume you have prepared your panel, and understand how to bond your system. For installation instructions regarding equipment and accessories not included here, refer to the instructions that came with those products.



**SHOCK HAZARD:** To avoid hazard of electrical shock, perform all mounting and wiring of the Kinetix 350 drive prior to applying power. Once power is applied, connector terminals can have voltage present even when not in use.

---



**ATTENTION:** Plan the installation of your system so that you can perform all cutting, drilling, tapping, and welding with the system removed from the enclosure. Because the system is open-type construction, be careful to keep any metal debris from falling into it. Metal debris or other foreign matter can become lodged in the circuitry and result in damage to components.

---

## Mount the Kinetix 350 Drive

Follow these steps to mount the drive.

1. Observe these clearance requirements when mounting the drive to the panel.

**IMPORTANT** Mount the module in an upright position as shown. Do not mount the module on its side.

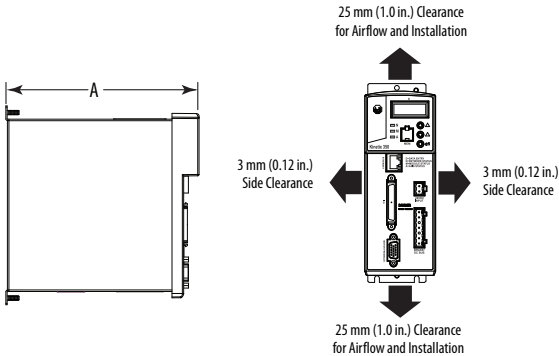

- Additional clearance and different hole patterns are required for side mount and rear mount AC line filters. See the table and [step 2](#) for more details.
- Additional clearance is required depending on the other accessory items installed.
- Additional clearance is required for the cable and wires connected to the top, front, and bottom of the drive.
- An additional 150 mm (6.0 in.) is required when the drive is mounted adjacent to noise sensitive equipment or clean wire ways.

Refer to [page 6](#) for Kinetix 350 drive dimensions.

Drive Cat. No.	Dimensions A mm (in.)
2097-V31PR0-LM	185 (7.29)
2097-V31PR2-LM	
2097-V32PR0-LM	230 (9.04)
2097-V32PR2-LM	
2097-V32PR4-LM	185 (7.29) <sup>(1)</sup>
2097-V33PR1-LM	
2097-V33PR3-LM	230 (9.04)
2097-V33PR5-LM	
2097-V33PR6-LM	185 (7.29) <sup>(1)</sup>
2097-V34PR3-LM	
2097-V34PR5-LM	230 (9.04)
2097-V34PR6-LM	

(1) If you are using an AC line filter, add 50 mm (2 in.).

- Mount the Kinetix 350 drive to the cabinet sub-panel with M4 (#6-32) steel machine screws torqued to 1.1 N•m (9.8 lb•in).

For catalog numbers 2097-V33PR1-LM, 2097-V33PR3-LM, 2097-V33PR5-LM, 2097-V34PR3-LM, and 2097-V34PR5-LM that use an AC line filter, refer to the AC Line Filter Installation Instructions, publication [2097-IN003](#), for the sub-panel mounting hole pattern.

### Kinetix 350 Drive Mounting Dimensions

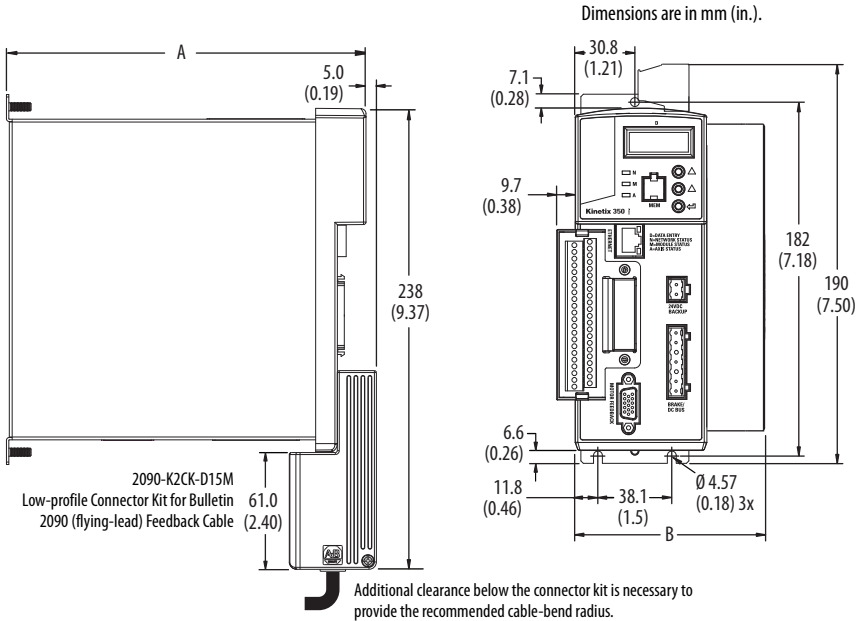

Cat. No.	Dimensions mm (in.)	
	A	B
2097-V31PR0-LM	185.1 (7.29)	68.0 (2.68)
2097-V31PR2-LM	185.1 (7.29)	68.5 (2.70)
2097-V32PR0-LM	229.6 (9.04)	68.0 (2.68)
2097-V32PR2-LM	229.6 (9.04)	68.5 (2.70)
2097-V32PR4-LM	229.6 (9.04)	86.8 (3.42)
2097-V33PR1-LM	185.1 (7.29)	68.0 (2.68)

Cat. No.	Dimensions mm (in.)	
	A	B
2097-V33PR3-LM	185.1 (7.29)	68.5 (2.70)
2097-V33PR5-LM	185.1 (7.29)	94.4 (3.72)
2097-V33PR6-LM	229.6 (9.04)	68.0 (2.68)
2097-V34PR3-LM	185.1 (7.29)	68.5 (2.70)
2097-V34PR5-LM	185.1 (7.29)	94.4 (3.72)
2097-V34PR6-LM	229.6 (9.04)	68.0 (2.68)

## Connector Data

Use this illustration to identify the Kinetix 350 drive features and indicators.

### Kinetix 350 Drive Features and Indicators

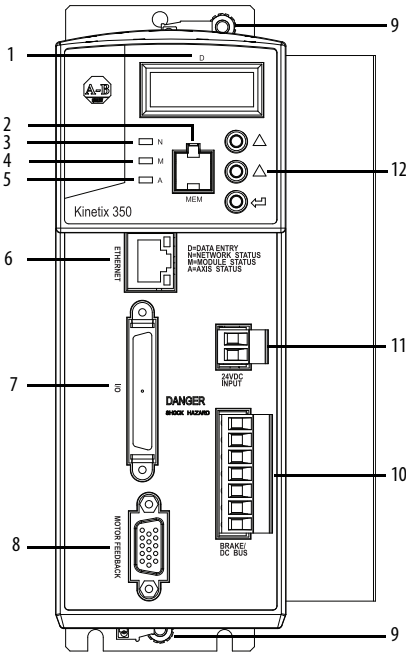

Item	Description
1	Data status indicator and diagnostic display
2	Memory module socket
3	Network status indicator
4	Module status indicator
5	Axis status indicator
6	Ethernet communication port (Port 1)
7	I/O (IOD) connector
8	Motor feedback (MF) connector
9	Ground Lug
10	Shunt resistor and DC bus (BC) connector
11	Back-up power (BP) connector
12	Display control push buttons (3)
13	Mains (IPD) connector
14	Motor power (MP) connector
15	Safe torque-off (STO) connector

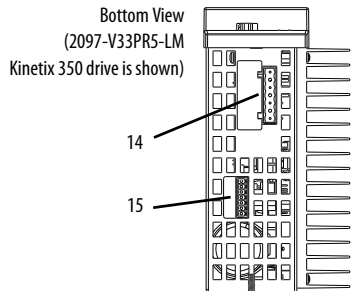
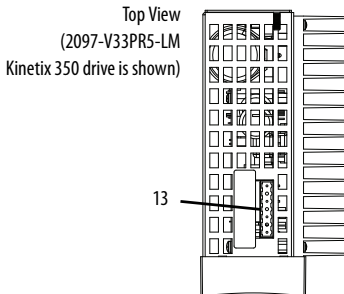

## Kinetix 350 Drive Connectors

Designator	Description	Connector
IPD	AC mains input power	4-position plug/header
PORT1	Ethernet communication port	RJ45 Ethernet
I/O	I/O	SCSI 50 pin high-density connector
MF	Motor feedback	15-pin high-density D-shell (male)
BP	Back-up power	2-pin quick-connect terminal block
BC	Shunt resistor and DC bus	7-pin quick-connect terminal block
MP	Motor power	6-pin quick-connect terminal block
STO	Safe torque-off (STO) terminal	6-pin quick-connect terminal block

## Mains (IPD) Connector Pinout

IPD Designator	Description	Signal
L3	AC power in (3-phase models)	L3
L2	AC power in	L2
L1	AC power in	L1
PE	Protective earth (ground)	PE

## Pin Orientation for 8-pin Ethernet Communication Port (port 1)

Port 1 Pin	Description	Signal
1	Transmit port (+) data terminal	+ TX
2	Transmit port (-) data terminal	- TX
3	Receive port (+) data terminal	+ RX
4	–	–
5	–	–
6	Receive port (-) data terminal	- RX
7	–	–
8	–	–

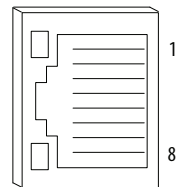



**I/O (IOD) Connector Pinout**

IOD Pin	Description	Signal
1...4	Reserved	–
5	Reserved	–
6	Reserved	–
7...25	Reserved (not used by Kinetix 350 drives)	–
26	± Overtravel, enable and home common	COM
27	Negative hardware overtravel	NEG_OT
28	Positive hardware overtravel	POS_OT
29	Drive enable	ENABLE
30	Home switch	HOME_SW
31...35	Reserved	–
36	Registration common	REG_COM
37...38	Reserved	–
39	Registration input	REG
40...42	Reserved	–
43	Brake release positive	BRAKE+
44	Brake release negative	BRAKE-
45...50	Reserved	–

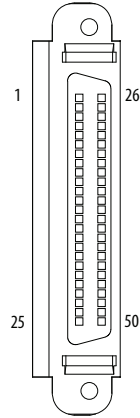

### Motor Feedback (MF) Connector Pinout

MF Pin	Description	Signal
1	Sine differential input+ AM+ differential input+	SIN+ AM+
2	Sine differential input- AM- differential input-	SIN- AM-
3	Cosine differential input+ BM+ differential input+	COS+ BM+
4	Cosine differential input- BM- differential input-	COS- BM-
5	Data differential input + Index pulse+	DATA+ IM+
6	Common	ECOM
7	Encoder power (+9V)	EPWR_9V <sup>(2)</sup>
8	Single-ended 5V Hall effect commutation	S3
9	Reserved	—
10	Data differential input - Index pulse-	DATA- IM-
11	Motor thermal switch (normally closed) <sup>(1)</sup>	TS
12	Single-ended 5V Hall effect commutation	S1
13	Single-ended 5V Hall effect commutation	S2
14	Encoder power (+5V)	EPWR_5V <sup>(2)</sup>
15	Reserved	—

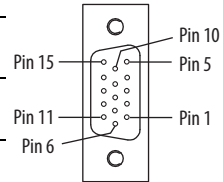

(1) Not applicable unless motor has integrated thermal protection.

(2) Encoder power supply uses either 5V or 9V DC based on encoder and motor used.

### Control Power Back-up (BP) Pinout

BP Designator	Description	Signal
+24V	Positive 24V DC	+24V DC
-24V	24V DC power supply return	Return

## Shunt Resistor and DC Bus (BC) Pinout

BC Designator	Description	Signal
+	Positive DC bus and shunt resistor	+
+		+
SH	Shunt resistor	SH
-	Negative DC bus	-
-		-

## Motor Power (MP) Pinout

MP Designator	Description	Signal
PE	Protective earth (ground)	PE
W	Motor power out	W
V	Motor power out	V
U	Motor power out	U

## Safe Torque-off (STO) Pinout

STO Pin	Description	Signal
1	+24V DC output from the drive	+24V DC control
2	+24V DC output common	Control COM
3	Safety status	Safety Status
4	Safety input 1 (+24V DC to enable)	Safety Input 1
5	Safety common	Safety COM
6	Safety input 2 (+24V DC to enable)	Safety Input 2

The Kinetix 350 drive ships with safe torque-off enabled. Connect safe torque-off inputs to a safety circuit, or install motion-allowed jumpers to obtain motion. Refer to the Kinetix 350 Single-axis EtherNet/IP Servo Drive User Manual, publication [2097-UM002](#), for details.

## Power Wiring Requirements

Wire must be copper with 75 °C (167 °F) minimum rating. Phasing of main AC power is arbitrary and earth-ground connection is required for safe and proper operation.

---

**IMPORTANT** The National Electrical Code and local electrical codes take precedence over the values and methods provided.

---

**Kinetix 350 Drive Power-wiring Requirements**

Cat. No.	Description	Terminals		Recommended Wire Size mm <sup>2</sup> (AWG)	Strip Length mm (in.)	Torque Value N·m (lb·in)
		Pin	Signal			
2097-V31PR0-LM 2097-V32PR0-LM 2097-V32PR2-LM 2097-V33PR1-LM 2097-V33PR3-LM 2097-V34PR3-LM 2097-V34PR5-LM 2097-V34PR6-LM	Mains input power		L3 L2 L1 PE	2.5 (14)	7 (0.28)	0.5 (4.5)
2097-V32PR4-LM 2097-V33PR5-LM				4.0 (12)	7 (0.28)	0.5 (4.5)
2097-V31PR2-LM 2097-V33PR6-LM				6.0 (10)	7 (0.28)	0.56...0.79 (5.0...7.0)
2097-V31PR0-LM 2097-V32PR0-LM 2097-V32PR2-LM 2097-V32PR4-LM 2097-V33PR1-LM 2097-V33PR3-LM 2097-V33PR5-LM 2097-V34PR3-LM 2097-V34PR5-LM 2097-V34PR6-LM 2097-V31PR2-LM	Motor power		PE W V U	2.5 (14)	7 (0.28)	0.5 (4.5)
2097-V33PR6-LM				4.0 (12)	7 (0.28)	0.5 (4.5)
2097-V31PR0-LM 2097-V32PR0-LM 2097-V32PR2-LM 2097-V32PR4-LM 2097-V33PR1-LM 2097-V33PR3-LM 2097-V33PR5-LM 2097-V34PR3-LM 2097-V34PR5-LM 2097-V34PR6-LM 2097-V31PR2-LM	Shunt resistor and DC bus <sup>(1)</sup>		+ + SH - -	2.5 (14)	7 (0.28)	0.5 (4.5)
2097-V33PR6-LM				4.0 (12)	7 (0.28)	0.5 (4.5)
2097-V3xPRx-LM	Control back-up power		+24V DC Return			
2097-V3xPRx-LM	Safe torque-off	STO-1 <sup>(2)</sup> STO-2 <sup>(2)</sup> STO-3 STO-4 STO-5 STO-6	+24V DC Control Control COM Safety Status Safety Input 1 Safety COM Safety Input 2	1.5 (16)	6 (0.25)	0.5 (4.5)

(1) Use only for shunt resistor connection.

(2) Use only for bypassing the STO circuit.



**ATTENTION:** To avoid personal injury and equipment damage, verify the following:

- Installation complies with specifications regarding wire types, conductor sizes, branch circuit protection, and disconnect devices. The National Electrical Code (NEC) and local codes outline provisions for safely installing electrical equipment.
- Motor power connectors are used only for connection purposes. Do not use motor power connectors to turn the unit on and off.
- Shielded power cables are grounded to prevent potentially high voltages on the shield.

## Ground Your Kinetix 350 Drive to the Subpanel

If the Kinetix 350 drive is mounted on a painted subpanel, ground to a bonded cabinet ground bus with a braided ground strap or 4.0 mm<sup>2</sup> (12 AWG) solid-copper wire, 100 mm (3.9 in.) long.

### Connecting the Braided Ground Strap

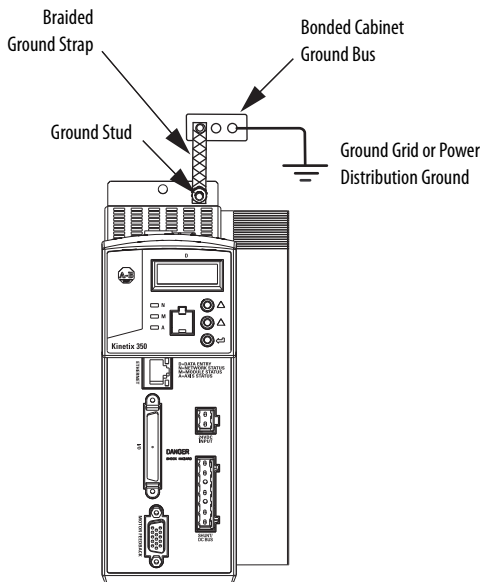

For dimensions, see [Kinetix 350 Drive Mounting Dimensions](#) on [page 6](#).

## Kinetix 350 Drive Motor-power Wire Shielding

A motor-power ground clamp and two #6-32 x 1 screws are supplied with the Kinetix 350 drive. Install the supplied motor-power ground clamp within 50...75 mm (2...3 in.) of the drive by using the two #6-32 x 1 screws.

### Motor Power Ground Clamp Installation

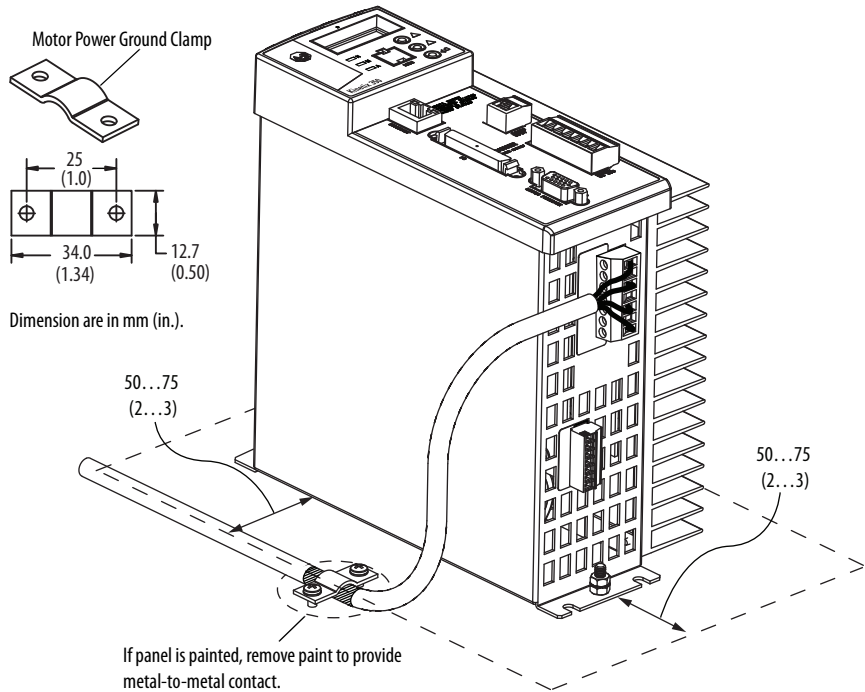

## Motor Overload Protection

This servo drive uses solid-state motor overload protection that operates in accordance with UL 508C. Motor overload protection is provided by algorithms (thermal memory) that predict actual motor temperature based on operating conditions as long as control power is continuously applied. However, when control power is removed, thermal memory is not retained.

In addition to thermal memory protection, this drive provides an input for an external temperature sensor/thermistor device, embedded in the motor, to support the UL requirement for motor overload protection.

Some motors supported by this drive do not contain temperature sensors/thermistors; therefore, motor overload protection against excessive consecutive motor overloads with power cycling is not supported.

This servo drive meets the following UL 508C requirements for solid-state overload protection.

Motor Overload Protection Trip Point	Value
Ultimately	100% overload
Within 8 minutes	200% overload
Within 20 seconds	600% overload



**ATTENTION:** To avoid damage to your motor due to overheating caused by excessive, successive motor overload trips, follow the wiring diagram provided in the user manual for your motor and drive combination.

Refer to your servo drive user manual for the interconnect diagram that illustrates the wiring between your motor and drive.

# Additional Resources

These documents contain additional information concerning related products from Rockwell Automation.

Resource	Description
Kinetix 350 Single-axis EtherNet/IP Servo Drives User Manual, publication <a href="#">2097-UM002</a>	Provides information on how to install, configure, startup, and troubleshoot your Kinetix 350 servo drive system.
Kinetix 300 Shunt Resistor Installation Instructions, publication <a href="#">2097-IN002</a>	Provides information on installing and wiring Kinetix 300 shunt resistors.
Kinetix 300 AC Line Filter Installation Instructions, publication <a href="#">2097-IN003</a>	Provides information on installing and wiring the Kinetix 300 AC line filter.
Kinetix 300 I/O Terminal Expansion Block Installation Instructions, publication <a href="#">2097-IN005</a>	Provides information on installing and wiring the Kinetix 300 I/O terminal expansion block.
Kinetix 300 Memory Module Installation Instructions, publication <a href="#">2097-IN007</a>	Provides information on installing the Kinetix 300 memory module.
Kinetix 300 Memory Module Programmer Quick Start, publication <a href="#">2097-OS001</a>	Provides information on using the memory module programmer to duplicate the memory module.
Kinetix Servo Drives Specifications Technical Data, publication <a href="#">GMC-TD003</a>	Provides product specifications for Kinetix Integrated Motion over EtherNet/IP, Integrated Motion over servos interface, EtherNet/IP networking, and component servo drive families.
Kinetix Motion Accessories Specifications Technical Data, publication <a href="#">GMC-TD004</a>	Provides product specifications for Bulletin 2090 motor and interface cables, low-profile connector kits, drive power components, and other servo drive accessory items.
Industrial Automation Wiring and Grounding Guidelines, publication <a href="#">1770-4.1</a>	Provides general guidelines for installing a Rockwell Automation® industrial system.
Product Certifications website, <a href="http://www.ab.com">http://www.ab.com</a>	Provides declarations of conformity, certificates, and other certification details.

You can view or download publications at <http://www.rockwellautomation.com/literature>. To order paper copies of technical documentation, contact your local Allen-Bradley distributor or Rockwell Automation sales representative.

Allen-Bradley, CompactLogix, ControlLogix, Kinetix, Rockwell Software, and Rockwell Automation are trademarks of Rockwell Automation, Inc.

Trademarks not belonging to Rockwell Automation are property of their respective companies.

Rockwell Otomasyon Ticaret A.Ş., Kar Plaza İş Merkezi E Blok Kat:6 34752 İçerenköy, İstanbul, Tel: +90 (216) 5698400

[www.rockwellautomation.com](http://www.rockwellautomation.com)

## Power, Control and Information Solutions Headquarters

Americas: Rockwell Automation, 1201 South Second Street, Milwaukee, WI 53204-2496 USA, Tel: (1) 414.382.2000, Fax: (1) 414.382.4444

Europe/Middle East/Africa: Rockwell Automation NV, Pegasus Park, De Kleetlaan 12a, 1831 Diegem, Belgium, Tel: (32) 2 663 0600, Fax: (32) 2 663 0640

Asia Pacific: Rockwell Automation, Level 14, Core F, Cyberport 3, 100 Cyberport Road, Hong Kong, Tel: (852) 2887 4788, Fax: (852) 2508 1846

## Publication 2097-IN008D-EN-P - July 2013

Supersedes Publication 2097-IN008C-EN-P - February 2013

Copyright © 2013 Rockwell Automation, Inc. All rights reserved. Printed in the U.S.A.



1 3 4 3 9 7 2 4