

T8195B/Q682B,C, Y8224A Heating or Cooling and Heating/Cooling New Construction Thermostat, Wallplate and Subbase

Installation Instructions for the Trained Service Technician.

Preparation

Check thermostat and subbase (if used) suitability for the heating, cooling, or heating/cooling system. Refer to Table 1.

Assemble tools required: flat bladed screwdriver, hand or power drill with 3/16-in. drill bit, wire cutter/stripper or sharp knife, bubble level or plumb bob and line.

Assure power is off to the heating, cooling, or heating/cooling system at the main fuse panel. Most buildings have a separate switch box or circuit breaker for disconnecting power to the heating and cooling (if applicable) equipment.

This thermostat is compatible with most heating, cooling, or heating/cooling systems. Refer to Table 1 for thermostat and system compatibility information.



Recycling Notice

This control contains mercury in a sealed tube. Do not place control in the trash at the end of its useful life.

If this control is replacing a control that contains mercury in a sealed tube, do not place your old control in the trash.

Contact your local waste management authority for instructions regarding recycling and the proper disposal of this control, or of an old control containing mercury in a sealed tube.

If you have questions, call Honeywell Inc. at 1-800-468-1502.

TABLE 1—THERMOSTAT AND SYSTEM COMPATIBILITY.

Type of Heating System to be Controlled	Conditions/Compatibility
Electric (Line Voltage)—typical baseboard and radiant	<ul style="list-style-type: none"> The R8239D1015 Isolating Relay or R841 Silent Switching Center must be installed in the thermostat control circuit.^a
Fan Coil Unit	<ul style="list-style-type: none"> Compatible. Assure correct subbase identity is selected for fan control.
Gas—Direct Spark Ignition (DSI), Intermittent Pilot (IP), and Standing Pilot (SP)	<ul style="list-style-type: none"> Compatible. Assure that 24V control transformer common is accessible for connection to thermostat cable conductor and power to the transformer is not regularly interrupted by high temperature or limit operation.
Heat Pump	<ul style="list-style-type: none"> Compatible. Assure correct subbase identity is selected for fan control and changeover control (O terminal for cool and B terminal for heat). Jumper Y to W for heat pump compressor control.
Hot Water Zone	<ul style="list-style-type: none"> Honeywell 2-wire valves are compatible. Some non-Honeywell 2-wire valves require an R8239D1015 Isolating Relay in the thermostat control circuit.^a Some 3-wire valves require an R8239A1052 Isolating Relay in the thermostat control circuit.^{a, b}
Oil	<ul style="list-style-type: none"> Assure that the 24V control transformer common is accessible for connection to thermostat cable conductor and power to the transformer is not regularly interrupted by high temperature, purge cycle, or limit operation.
Vent Damper	<ul style="list-style-type: none"> Honeywell damper motors are compatible. Some non-Honeywell damper motors require an R8239D1015 Isolating Relay in the thermostat control circuit.^a Check control amperage requirement.
Warm Air Zone	<ul style="list-style-type: none"> Most are compatible.

^a If thermostat is not compatible with the system being controlled, the system will not operate. No hazard exists. The thermostat will not be damaged unless it is used to directly control a line voltage system. For proper system operation, a Honeywell R841 or R8239D1015 Isolating Relay must be added to the thermostat control circuit.

^b Consult manufacturer for installation requirements.

Installation

WHEN INSTALLING THIS PRODUCT...

1. Read these instructions carefully. Failure to follow them could cause a hazardous condition.
2. Installer must be a trained experienced service technician.
3. After installation is complete, check out product operation as provided in these instructions.

IMPORTANT: An incorrectly leveled subbase will cause the temperature control to deviate from setpoint. It is not a calibration problem.



CAUTION

1. Disconnect power supply to prevent electrical shock or equipment damage.
2. To prevent interference with the thermostat linkage, keep wire length to a minimum and run wires as close as possible to the subbase.
3. Do not overtighten thermostat captive mounting screws because damage to subbase threads can result.
4. Do not short across coil terminals on relay. This can burn out the thermostat heat anticipator.

LOCATION

Locate thermostat about 5 ft [1.5m] above the floor in an area with good air circulation at average temperature.

Do not mount the thermostat where it may be affected by:

- drafts, or dead spots behind doors and in corners.
- hot or cold air from ducts.
- radiant heat from the sun or appliances.
- concealed pipes and chimneys.
- unheated (uncooled) areas such as an outside wall behind the thermostat.

Run wires from the heating, cooling, or heating/cooling equipment to the new thermostat location.

IMPORTANT: This control requires an additional conductor to the control transformer common (e.g., a typical 2-wire heating system requires three wires be pulled, a 4-wire heating/cooling requires five wires).

UNPACK THERMOSTAT

Handle your new thermostat carefully; rough handling may interfere with its accuracy. Before unpacking, refer to Fig. 1.

Remove and discard the shipping wrap.

IMPORTANT: Save package of screws and instructions for the homeowner.

Remove the thermostat cover by lifting from the bottom. Set aside cover until needed later.

Carefully remove the material protecting the mercury switch bulb.

Loosen two captive mounting screws, and separate wallplate (if provided) from back of thermostat base.

MOUNT WALLPLATE OR SUBBASE

Wall Mounting (Fig. 2)

Hold the wallplate or subbase in position on wall (Fig. 2). Mark holes on the wall for anchors. Use spirit level to make sure the wallplate or subbase is level.

Fig. 1—Unpack thermostat.

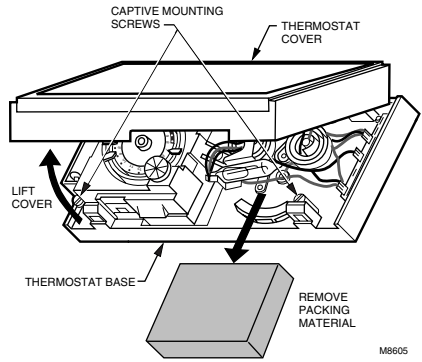

Drill 3/16-in. holes, and gently tap anchors into holes until flush with the wall.

Pull wires through the large wiring hole in the wallplate or subbase.

Loosely fasten the wallplate or subbase to the wall with the three screws. Do not completely tighten the screws.

Carefully level the wallplate or subbase (Fig. 3), and firmly tighten the screws.

Fig. 2—Mounting wallplate or subbase to wall.

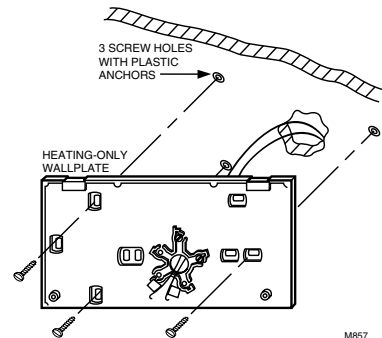
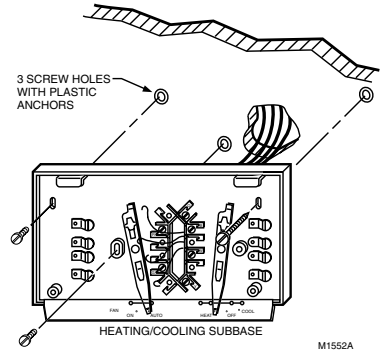
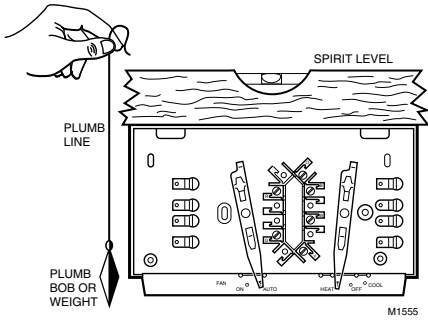

Fig. 3—Leveling methods for wallplate or subbase.



Outlet Box Mounting (Fig. 4)

Use a horizontally mounted outlet box if possible. If a vertical outlet box is used, mount the wallplate or subbase on a 202689A Cover Plate Assembly (ordered separately). Follow the instructions provided with the cover plate assembly.

Align the wallplate or subbase mounting holes on the outlet box and loosely fasten with two screws.

Carefully level the wallplate or subbase (Fig. 3), and firmly tighten the screws.

WIRE WALLPLATE OR SUBBASE

Follow the instructions provided by the heating, cooling or heating/cooling equipment manufacturer. If not available, refer to the Typical Wiring Diagrams section at the end of this publication.

Disconnect the power supply before making wiring connections to prevent electrical shock or equipment damage.

NOTE: All wiring must comply with local electrical codes and ordinances.

Wallplate (Heating or Cooling Systems)

Refer to Fig. 5 and strip the thermostat wire insulation as necessary.

For heating-only systems, connect wires to R, W, and C terminals. For cooling-only systems, connect wires R, Y, and C terminals. Firmly tighten the screws. The system low-voltage transformer powers the timer (Fig. 11).

Push excess wire back into the wall.

Plug the hole in the wall with nonhardening caulk, putty, or nonflammable insulation to prevent drafts from affecting thermostat operation.

Subbase (Heating/Cooling Systems)

Refer to Fig. 5, and strip the thermostat wire insulation as necessary.

Connect the wires to the corresponding terminals on the subbase. If labels do not agree with your new subbase, refer to Table 2 and the installation instructions furnished with the subbase.

Fig. 4—Mounting wallplate or subbase on horizontal outlet box.

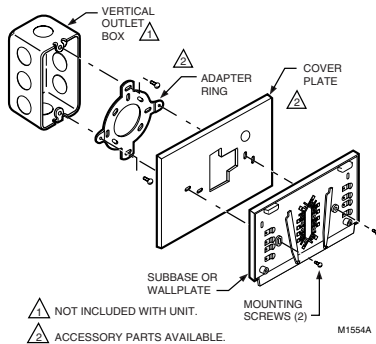
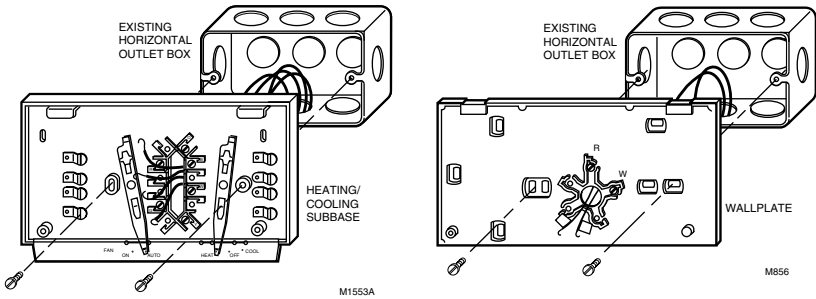

Fig. 5—Methods of connecting terminals.

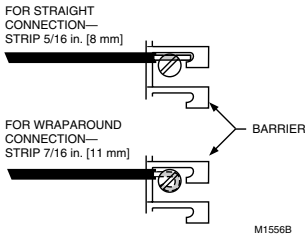

TABLE 2—TERMINAL DESIGNATIONS.

Subbase Terminal	Control Function
R	Control transformer power.
W	Heating control circuit.
Y	Cooling control circuit; jumper to W for heat pump compressor control if no P terminal on subbase.
G	Fan control circuit.
C	Clock control (transformer common).
O	Cooling damper or changeover/reversing valve, makes continuously in cool.
B	Heating damper or changeover/reversing valve, makes continuously in heat.

The timer is powered by the system low-voltage transformer. 24 Vac must be maintained across terminals R and C. Push excess wire back into the wall.

Plug the hole in wall with nonhardening caulk, putty, or nonflammable insulation to prevent drafts from affecting thermostat operation.

MOUNT THE THERMOSTAT

Note the tabs on the top inside edge of the thermostat base. These tabs fit the slots molded into the top of the wallplate or subbase.

Hang the thermostat base on the wallplate or subbase.

Insert the two captive mounting screws located in the bottom corners of the base (Fig. 6).

Firmly tighten the screws.

INSERT TIMER BATTERIES (OPTIONAL)

Power is supplied to the clock by the 24-Vac transformer. Two AAA alkaline backup batteries (not included) may be installed to supply power to the timer if power is interrupted due to power failure.

Install the batteries in the thermostat (Fig. 7).

Once a year or when batteries are dead, replace with two new AAA alkaline batteries. We recommend Energizer® batteries.

Fig. 6—Thermostat mounting.

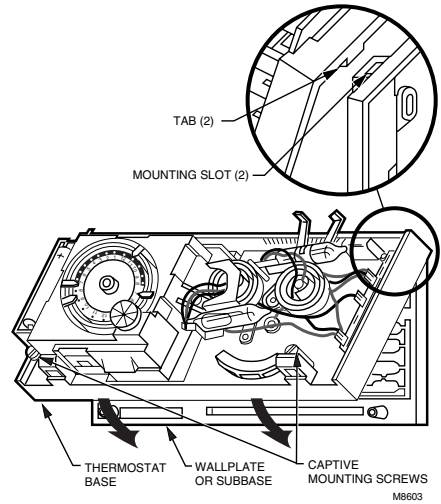
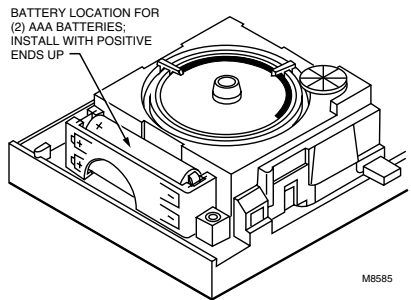

Fig. 7—Insert timer backup batteries.



SET TIMER

Adjust the clock by moving the knob clockwise ↻. Do *not* reverse the knob.

When time is correctly set, the time indicator arrow (triangle shape) points to the corresponding daytime (light) or nighttime (dark) portion of the program dial.

ATTACH THERMOSTAT COVER

Make sure the packing inserts in the thermostat base are removed.

Place the two tabs on the upper edge of the cover into the mounting slots in the thermostat base (Fig. 9).

Swing the cover downward until it catches at the bottom of the base.

Fig. 8—Set timer.

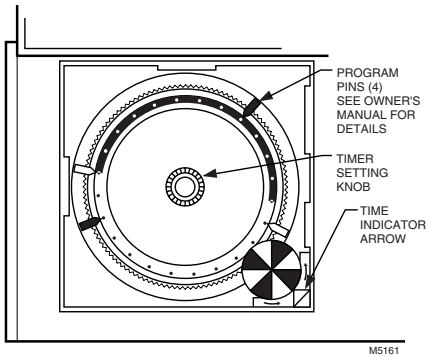
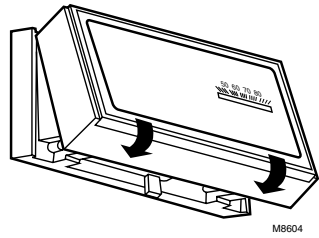

Fig. 9—Attach cover.



SET TEMPERATURE CONTROL LEVERS

The two levers on the top of the thermostat control the low and high temperatures for energy savings and comfort control (Fig. 10). The lever on the left (blue mark) controls the lower temperature. The lever on the right (red mark) controls the higher temperature.

We recommend pushing the levers together at an appropriate temperature for either heat or cool until the occupant programs the thermostat and makes the final temperature selections.

SET SUBBASE SWITCHES (IF APPLICABLE)

The subbase system switch controls system operation as follows:

HEAT: Heating system is controlled by the thermostat. Cooling system is off.

COOL: Cooling system is controlled by the thermostat. Heating system is off.

OFF: Both the heating and cooling systems are off. If the fan switch is in the AUTO position, the fan is also off.

The subbase fan switch controls fan operation as follows:

ON: Fan operates continuously.

AUTO: Fan operates with the cooling equipment as controlled by the thermostat or with the heating equipment as controlled by the plenum switch. In electric heat, heat pump, and fan coil systems, the fan is controlled by the thermostat in heating and cooling.

To switch positions, use thumb or index finger to slide lever to the desired position. For proper circuit operation, switch lever must stop in detent over the desired function indicator mark.

Fig. 10—Temperature control levers.

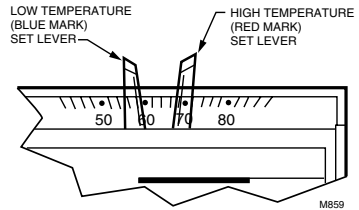

Checkout



CAUTION

Do not check operation by shorting across terminals of system controls. This will damage the heat anticipator.

HEATING-ONLY SYSTEM

Turn on power to the furnace.

Push both temperature setting levers together at least 5° F [3° C] above the room temperature. The main burner should come on. The fan will start when the furnace heats up.

Move both levers 5° F [3° C] below the room temperature. The burner should shut off.

Operate the entire heating system at least one complete cycle.

If thermostat fails any test, refer to the Troubleshooting Guide in the Owner's Manual.

Reset both the temperature setting levers to the desired temperatures.

COOLING-ONLY SYSTEM

Turn on power to the cooling equipment.

Push both temperature setting levers together at least 5° F [3° C] below the room temperature. The cooling equipment will operate, and the fan will start. Allow for any time delay that may be built into the compressor control circuit.

NOTE: To avoid compressor damage, do not operate the system when outdoor temperature is below 50° F [10° C]. Refer to manufacturer recommendations.

Move both levers 5° F [3° C] above room temperature. The cooling equipment and the fan should shut off.

Operate the entire cooling system at least one complete cycle.

If thermostat fails any test, refer to the Troubleshooting Guide in the Owner's Manual.

Reset both the temperature setting levers to the desired temperatures.

HEATING/COOLING SYSTEM

Turn on power to the furnace and cooling system.

Place the system switch lever to HEAT and fan switch lever to AUTO.

Push both temperature setting levers together at least 5° F [3° C] above room temperature. The main burner should come on. The fan will start when the furnace heats up. (If central electric heat, fan coil or heat pump system, fan starts immediately.)

Move both levers 5° F [3° C] below room temperature. The burner should shut off.

Place the system switch lever to COOL and the fan switch lever to AUTO. The cooling equipment will operate, and the fan will start. Allow for any time delay that may be built into the compressor control circuit.

NOTE: To avoid compressor damage, do not operate the system when outdoor temperature is below 50° F [10° C]. Refer to manufacturer recommendations.

Move both temperature setting levers together at least 5° F [3° C] above the room temperature. The cooling equipment should shut off.

Place the fan switch to ON. The fan should run continuously with the system switch in any position.

Place the system switch to OFF. Move both temperature setting levers to various positions. The heating and cooling systems should not operate.

Operate the entire system for at least one complete cycle with the system switch at COOL and one complete cycle with the switch at HEAT.

If thermostat fails any test, refer to the Troubleshooting Guide in the Owner's Manual.

Reset both the temperature setting levers to the desired temperatures.

Leave Owner's Manual and Assistance Information in a convenient place for the building occupant or provide with other appliance manuals.

Typical Wiring Diagrams

Follow the hookup diagram supplied with your heating, cooling, or heating/cooling equipment. If not available, use Figs. 11 through 13 as a guide.

REMEMBER: Your wiring must follow local electrical codes and ordinances.

Fig. 11—Typical hookup for T8195B Thermostat and Q682C Wallplate in gas heating control system.

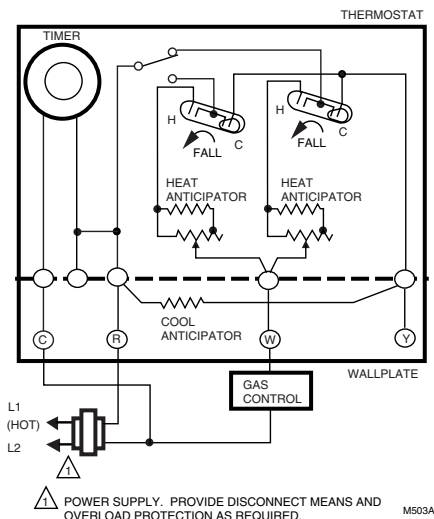
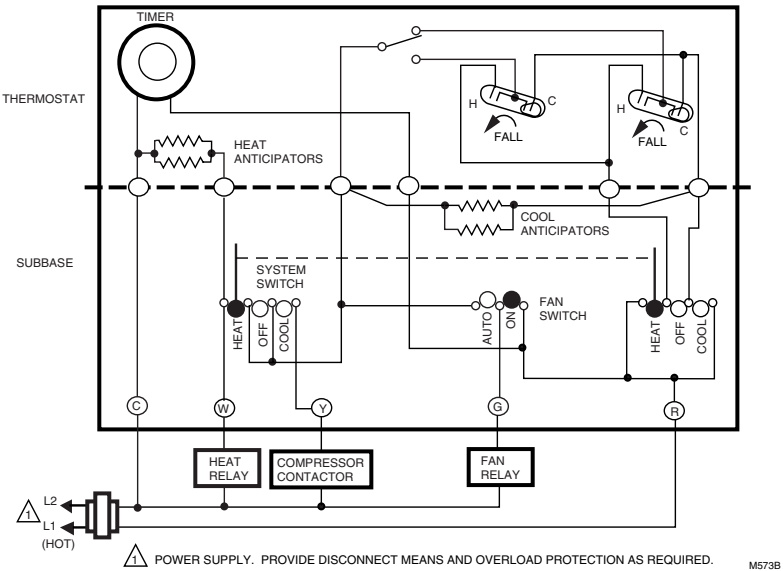
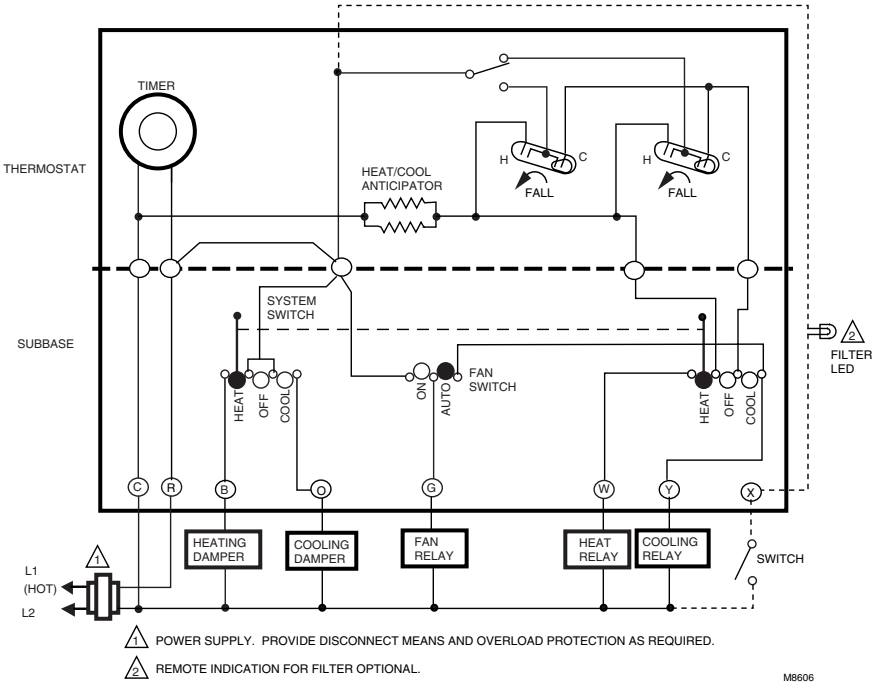

Fig. 12—Typical hookup for T8195B Thermostat and Q682B Subbase in conventional heating/cooling system.



Honeywell

Automation and Control Solutions

Honeywell International Inc.
1985 Douglas Drive North
Golden Valley, MN 55422

Honeywell Limited—Honeywell Limitée
35 Dynamic Drive
Scarborough, Ontario M1V 4Z9



Printed in U.S.A. on recycled
paper containing at least 10%
post-consumer paper fibers.