



OPERATION & MAINTENANCE MANUAL CELLULAR CDMA/GSM REPEATER MODEL RPT 9000



Document Release Date: April 20th 2007

Any modifications to this device will void FCC and IC approvals.

OPERATIONS & MAINTENANCE MANUAL CELLULAR REPEATER MODEL RPT 9000

TELCOSAT RPT 9000

Model RPT 9000U UPLINK
Model RPT 9000D DOWNLINK

The information set forth in this document and all rights in and to inventions disclosed herein, and patents which might be granted thereon disclosing, employing or covering the materials, methods, techniques or apparatus described herein are the exclusive property of Telcosat Inc.

This document is an operation and maintenance manual. No disclosure or reproduction of the information or drawings shall be made of any other purpose without the prior written consent of Telcosat Inc. Use of the information contained herein to fabricate or assemble any item in whole or in part is expressly prohibited.

Any modifications to this device will void FCC and IC approvals.



SAFETY SUMMARY

High voltage is used in the operation of this equipment. Death on contact may result if personnel fail to observe the following safety precautions:

- Only qualified trained personnel can install this equipment. Electrical connection and installation must meet your local Electrical Safety Installation codes.
- Prior to any maintenance or inspection of this device disconnect the power supply.
- Do not remove covers or access plates on the equipment unless you are a trained technician and authorized to carry adjustment and maintenance for this apparatus.
- When installing antennas always be aware of high voltage overhead power lines. Contact with power lines will result in severe injury and or death.
- To prevent electrical shock or damage to the equipment, do not operate the repeater until you thoroughly understand the operation and function of all controls, indicators, and connectors.
- The RPT9000 Repeater weighs approximately 45 lbs/ 22kilograms. The repeater must be attached to the appropriate supporting device using the welded supporting lugs on the enclosure. The nuts and bolts must be a minimum Grade 5, 1/4" (6mm) diameter and corrosion resistant.

FIRST AID

In case of electrical shock:

THIS PERSON COULD STILL BE IN CONTACT WITH ELECTRICAL POWER. DO NOT TOUCH THIS PERSON BEFORE YOU INSULATE YOUR SELF FROM THE ELECTRICAL SOURCE.

- Turn off the electrical power.
- If you cannot turn off the electrical power, pull, push, or lift the person to safety using a dry wooden pole, a dry rope, or some other insulating material. Do not use any metallic objects to move this person.
- After the injured person is no longer in contact with the electrical source, obtain/perform immediate medical attention.

TABLE OF CONTENTS

SAFETY SUMMARY-----Page 4
 FIRST AID-----Page 4
 TABLE OF CONTENTS-----Page 5

CHAPTER 1

1.1 GENERAL Page 6
 1.2 INTRODUCTION Page 6
 1.2.1. MATERIALS Page 6
 1.2.2 RPT 9000 APPLICATIONS Page 6
 1.3 RPT 9000 SPECIFICATIONS Page 7
 1.4 TECHNICAL ASSISTANCE Page 7

OPERATIONAL OVERVIEW **CHAPTER 2** Page 8
 2.1 GENERAL Page 8
 2.2 REPEATER MODULE RF PATHS Page 8
 2.3 DETAILED TECHNICAL RF SIGNAL PROCESSES Page 9
 2.4 AC POWER DISTRIBUTION Page 10

INSTALLATION **CHAPTER 3**
 3.1 WARNING Page 10
 3.2 TOOLS REQUIRED Page 10
 3.3 ANTENNA REQUIREMENTS Page 11
 3.4 ANTENNA ISOLATION & COAX CABLES Page 12
 3.5. INSTALLING YOUR REPEATER Page 13
 3.6 POWER AND ATTENUATOR SWITCH SETTINGS Page 14
 3.7 RSSI INDICATOR AND SIGNAL LEVELS Page 14
 3.8 ALIGNING YOUR ANTENNA Page 14
 3.9 ADJUSTING UPLINK POWER Page 15

WARRANTY REPAIR **CHAPTER 4** Page 16
 4.1 WARRANTY Page 16
 4.2 LIMITED WARRANTY Page 16

EQUIPMENT STORAGE **CHAPTER 5** Page 17

APPENDIX A TECHNICAL SPECIFICATIONS TABLE ONE Page 18
APPENDIX A RF EXPOSURE LEVELS Page 19
APPENDIX B RETURN GOODS PROCEDURE Page 20
 B2. Returned Goods Procedure Page 20
 B3. Shipping Procedure Page 20
 B4. Returned Shipments Page 20
 B5. Repair / Return Status Page 20

LIST OF FIGURES

Figure 1-1 RPT 9000 in a typical repeater remote site set up configuration Page 7
 Figure 2-1 RPT 9000 UP and DOWNCONVERTER Blocks Page 9

LIST OF TABLES

Table 1- Technical Specifications Page 19

CHAPTER 1

SCOPE

1.1 GENERAL

The TELCOSAT RPT 9000 Cellular Repeater (consisting of UPLINK and DOWNLINK bidirectional system) contains operational and maintenance information. This manual consists of four chapters and two appendices as follows:

- Chapter 1 outlines the manual contents, with description and general application notes
- Chapter 2 contains an operational overview and tune-up procedures (single and multi carrier).
- Chapter 3 contains installation procedures, packing and shipping instructions.
- Chapter 4 contains the repeater warranty information
- Appendix A contains unit specifications and environmental data.
- Appendix B contains the return goods procedure.

1.2 INTRODUCTION

The TELCOSAT RPT 9000 is a bidirectional system consisting of UPLINK and a DOWNLINK modules used in locations requiring coverage, where conventional communication systems cannot reach, such as buildings, parking structures, tunnels and remote areas. The TELCOSAT RPT 900 is designed to provide coverage by using reliable, high intercept components.

Adjustable RF Gain is provided in each direction of communication (donor to portable and portable to donor) to compensate for attenuation losses of over air links. Throughout this manual, the terms DOWNLINK and UPLINK are used. Downlink is the direction of RF energy from the Base Station Donor to the Mobile or Portable Subscriber. Uplink is the path direction from the Mobile or Portable Subscriber to the Base Station Donor.

1.2.1 Materials

The materials supplied with the Repeater are the Up and Downlink modules, amplifiers, power supplies user manual.

1.2.2 Applications

The RPT 9000 cellular repeater can be used as part of a complete in building package or as a stand-alone Cell extender in remote areas.

Planning details for a complete in-building system are not included in this document.

Fig. 1-1

Typical TELCOSAT INC remote location Site System

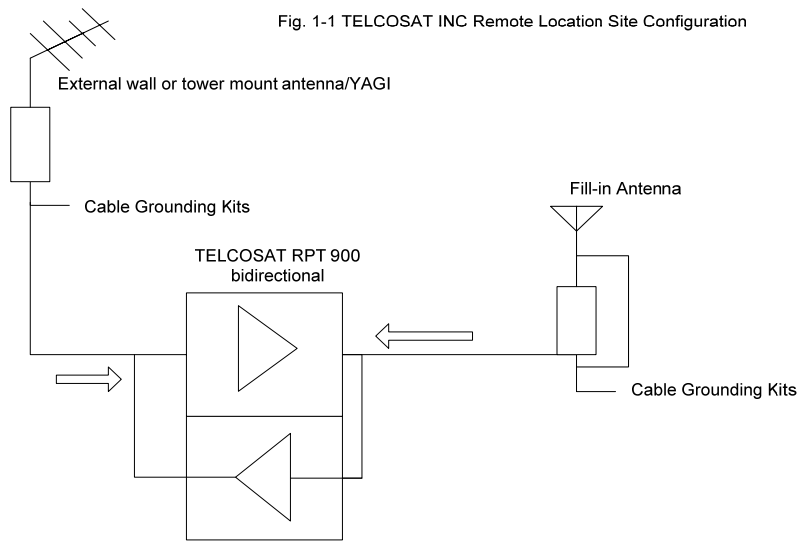

Fig. 1-1

1.3 RPT 9000 SPECIFICATIONS

Appendix A contains the TELCOSAT RPT 9000 Repeater Specifications.

1.4 TECHNICAL ASSISTANCE

Technical assistance on the TELCOSAT RPT 9000 Repeater is available through:

TELCOSAT Customer Service Center
Phone: 1-403-291-4031
Fax: 1-403-291-3059

CHAPTER 2

OPERATIONAL OVERVIEW

2.1 GENERAL

The TELCOSAT RPT 9000 provides service at cellular radio frequencies. The operational overview is presented in Fig 1-1

Downlink RF signals from a donor cell site are routed through a pick-up antenna, through a Diplexer then continues to be process by the amplifier chain. The RF is amplified for path and cable losses and filtered to reject out-of-band IM products and unwanted radio signals. The downlink RF is injected into a fill-in antenna (coverage antenna) for null-area coverage.

The Up-link signals from mobile units are received into the coverage antenna of the repeater. The incoming signal then passes through a Diplexer, then amplified in the Up-link modules and finally the power amplifier. The Up-link process is the same as the Down-Link process.

2.2 REPEATER MODULES

The Up-link RF path are isolated from the Down-link RF path by utilizing Cavity Band Pass Diplexers and Saw Band-pass filters (BPF) that provide out-of-band rejection.

Figure 2-1 illustrated a simplified block diagram of the RPT 9000 Cellular Repeater.

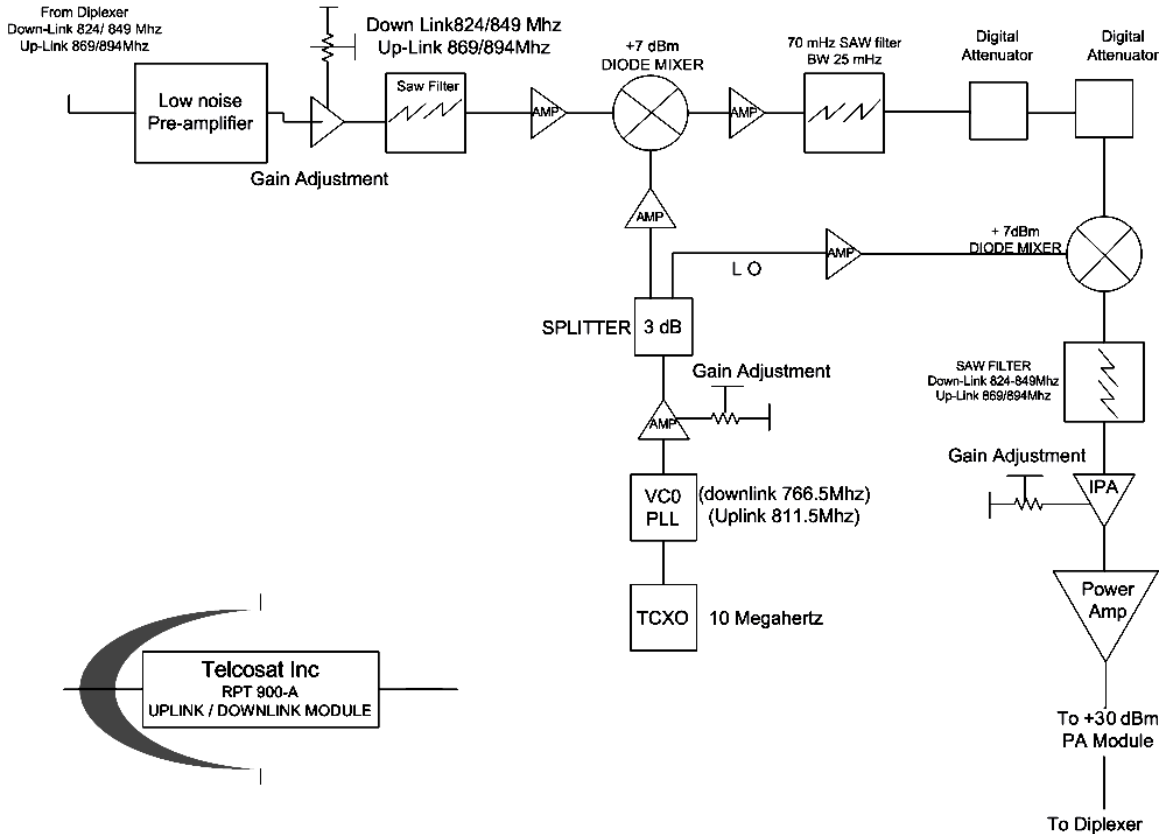

Figure 2

2.3 Detailed Technical RF Signal Processes

A YAGI antenna with a certain directional gain provides the donor signal from the cell site, feeds the band pass diplexer, and the downlink pre-amplifier which has low noise and a high intercept point with a Gain of 20 dB. The Rx signal then passes through a UHF SAW filter and is then down converted to a 70 MHz IF frequency filtered by a 25 MHz wide SAW filter. The 18 dB of attenuation introduced by the SAW filter is compensated for, by a 40 dB gain (linear in dB) VGA with AGC detector, chip amplifier.

The IF signal gain is controlled further more by digitally controlled attenuators for a total of 50 dB in 2 dB steps (See Figure 1-1).

The following converter section converts the IF signal frequency-true back up to the original Rx frequency and adds additional 50 dB of gain with an IP3 of + 26 dBm. This section will provide a + 2 dBm maximum average output power (with CDMA modulation).

A +30 dBm Power Amplifier (PA) module follows to attain the targeted output power. The module is using LDMOS RF amplifier mmic developed for ultra linear CDMA Multi-Carrier applications. The third order intercept of this module is +50dBm typical.

Two modules, one for the uplink and one for the downlink paths of the repeater are employed. They are electronically identical and their gain can be adjusted individually.

The repeater is set internally to a fixed 45dB of gain, plus another 50dB of adjustable gain is available via the manual attenuator switches to make a combined total of 95dB overall gain. The Up-Link and the Down-Link each have 95dB of gain.

Bar-graph Led's in the up and down Link Modules are available for RSSI measurements for easy set up of repeater sites.

2.4 AC POWER DISTRIBUTION

AC input power is through a power cord then a 2-pole on/off circuit breaker switch which feeds two DIN rail mounted fuse holders with cartridge fuses rated at 1 AMP and 2 AMPS. The fuses are replaceable and each DIN rail fuse holder holds a spare fuse. AC power from the DIN rail fuse holders feed two DIN rail switching power supply units. The power supply units are adjustable to operate on either 120 VAC or 230VAC. (Customer to notify Telcosat Inc with AC power requirement prior to shipping)

The internal power supply units convert AC line voltage to DC power, one power supply unit supplies 10volts DC and the other power supply unit provides 28volts DC. The DC power provides all the necessary requirements for the active components.

CHAPTER 3 INSTALLATION

Any modifications to this device will void FCC and IC approvals.

READ THESE INSTRUCTIONS PRIOR TO INSTALLATION

**DETAILED SET UP INSTRUCTIONS FOR YOUR RPT9000
CELLULAR REPEATER.**

WARNING

**DO NOT POWER UP THE REPEATER WITH OUT THE
ANTENNAS CONNECTED**

3.1 WARNING

Cellular Repeaters should be installed by fully trained technicians. Improper installation and excessive RF power levels can cause interference with the operation of cellular towers.

Antennas must be mounted in a secure safe manner and according to safe working practices. Lightning protection should be installed on every cellular repeater unit.

Antennas must not be installed near overhead electrical power lines as this can cause serious injury and or death.

If you require any additional installation guidelines then please consult your supplier or consult with an RF Systems Engineer.

3.2 TOOLS REQUIRED

Spectrum analyzer with a tracking generator, frequency ranges 1 Gigahertz.

Optional Signal Generator for onsite testing of the repeater, frequency range of 4 Gigahertz.

Hand held cable fault locator (TDR)

Multi-meter

Hand tools.

Water proofing tape.

Coax cable straps for support.

Cellular Phone.

3.3 ANTENNA REQUIREMENTS

ANTENNAS: please read your manufacturers antenna specifications before installation. Your antenna will require a type “N” connection. The antenna, coax, and fittings must be 50 ohms impedance.

The cellular repeater requires antennas that operate in the desired frequency range of the cellular repeater. The RPT9000 Repeater has a frequency operating range of 824 to 849 Megahertz for the up link, and 869 to 894 Megahertz for the downlink. Your antennas must operate within these frequencies.

Failure to select the proper antennas will greatly degrade the performance of your repeater.

NOTE:

“UP-LINK” is the radio link from your hand held cellular phone to the cellular tower in the frequency range of 824 to 849 Megahertz

“DOWN-LINK” is the radio link from the cellular tower to your cellular phone in the frequency range of 869 to 894 Megahertz.

The repeater requires two antennas to be connected to the system. See image showing coax connectors on the bottom of the repeater enclosure.

The Donor antenna is the antenna pointing to the Cellular Tower and the Area Fill antenna is the antenna that provides the fill signal to your desired area.

3.4 ANTENNA ISOLATION & COAX CABLES

All repeaters require antenna isolation to prevent oscillation. The usable gain level of your repeater is directly linked to the antenna isolation values. The maximum gain of your repeater must be adjusted to 10 to 15dBm lower than your antenna isolation values. For example, if your antenna isolation value is 75dBm then your maximum usable repeater gain is 60dBm.

Due to the variations of system layouts and requirements it is not possible to have one procedure that will suffice every installation. You are strongly advised to acquire the services of an RF system designer to calculate your antenna isolation requirements.

Ensure that your antennas are at the maximum possible distance apart. Do not place antennas in close proximity to each other.

Coax cables should be low loss 50 ohm, and suitable for 800 megahertz band frequency.

Antenna connections should be clean and moisture free. Do not spray lubricant into the connectors as this prevents the signal traveling through the coax. Use a cleaning solvent that has no oil and does not leave any residue. High quality oil-less contact cleaner is suitable.

All coax connectors must be water tight and wrapped with water proof tape. Any moisture in the connectors will degrade or eliminate the signals.

PREPARING YOUR CELLULAR REPEATER



Figure 3

3.5 Installing your Repeater

The Telcosat Repeater weighs in excess of 40 pounds (20 Kilograms)
Make sure that your repeater is securely bolted to a suitable support. There are four welded steel tabs on each corner that must be used to bolt your unit onto a suitable support system. You must use 1/4" diameter grade five steel corrosion resistant bolts with lock washers and securing nuts, a total of 4 bolts and nuts/lock washers are required.

Bottom of enclosure showing antenna connections



Figure 4

Only when you have safely connected and installed your antennas and coax then proceed to the next step. **DO NOT CONNECT TO THE POWER SUPPLY.**

3.6 POWER AND ATTENUATION SWITCH SETTINGS

Open the door on the Repeater and you will see two modules with a row of switches on each Module

The left side Module marked Donor, controls the power level that transmit back to the cellular tower. The right side box marked Area Fill controls the power levels to your area fill.

The rows of switches have numbers engraved below each switch and above the switches the word Attenuate are also engraved into the box.

When the switches are in the up position towards the word Attenuate this means the signal levels are reduced. (Attenuate means to reduce the signal level). When you want to increase power you toggle the switch down, to decrease power you toggle the switch up.

The numbers below the switches are calibrated in dBm. For instance, the switch numbered 20 means that if the switch is towards the attenuate side (toggled up) then the signal is reduced by 20 dBm. If the same switch is toggled down then the transmit power is increased by 20dBm.

3.7 RSSI METER AND SIGNAL LEVELS

Your Repeater is fitted with a RSSI (Receive Signal Strength Indicator) Your RSSI indicator is located just above your row of attenuator switches and is displayed as green Led's.

The right hand side RSSI window is your receive signal from the cellular tower. (Area Fill)

The left hand side RSSI window is your receive signal from mobile cellular phones.

(NOTE: THE RSSI INDICATOR DISPLAYS RECEIVE SIGNAL STRENGTH ONLY. THEY DO NOT DISPLAY TRANSMIT POWER.)

The RSSI indicator has a dynamic range of -80 dBm to – 65dBm.

The green Led's display will start to illuminate when a signal strength of -80dBm or greater is received. When aligning your antenna to the cellular tower the RSSI meter must be monitored during setup. When you rotate your antenna you will see the RSSI indicator increase and decrease as you pass the signal with your antenna.

This RSSI window on the Area Fill side (Right Side Module) should not have all the green Led's displayed. If the Led's are 100% green then this indicates that you have too much receive signal from the cellular tower. The maximum required RSSI level is approximately 80% of the green illuminated Led display bars.

3.8 ALIGNING YOUR DONOR ANTENNA TO A CELLULAR TOWER

It is very important not to have too much signal from the cellular tower on the "Area Fill" input signal. Full bars on the right hand side green LED RSSI display indicate possible signal excess.

Rotate your antenna until you pick up a cellular signal from a Cell tower. If the signal strength is greater than -80dBm then the LED window on the Donor side will start to illuminate. Adjust the antenna until the received signal is peaked. Check to see that the green Led display is not more than about 80% illuminated. If you have 100% solid green lights on the right side display window then you must reduce the receive signal level.

You can reduce the received signal level two ways.

- 1) Replace your Donor antenna with a lesser gain antenna.
- 2) If your system design will permit, slightly rotate the antenna away from the maximum signal until the RSSI window reads about 80% of maximum display level.

After adjusting the receive signal levels from the Cellular Tower we now adjust the power levels for the area fill. (Down-Link Signal)

For the next step you can use your cellular phone signal level indicator or preferably a spectrum analyzer.

Toggle down the area fill switches in 2dBm steps until the desired power levels have been obtained.

3.9 ADJUSTING UP-LINK TRANSMIT POWER TO CELLULAR TOWER

It is important to only use the minimum required power level for the Up-Link transmit power. The required power level can be provided from a RF Systems Engineer or appropriate RF Path Loss computer software.

CONNECT A SPECTRUM ANALYZER OR AN RF POWER METER TO MEASURE MAXIMUM TRANSMIT POWER FOR THE UPLINK AND DOWN LINK CARRIER.

Maximum permissible RF transmit power is 30dBm for a single carrier and 26.5 dBm for two carriers.

Make a test call while the repeater is adjusted to the minimum gain on the Uplink Frequency (824/849 MHz)

When making the test call on your cellular phone you must be a minimum of 30 metres (100ft) from the area fill antenna.

If you cannot complete the call increase power in 2 dBm increments. Make a test call after every adjustment.

NOTE: YOUR REPEATER HAS THE CAPABILITY TO BOOST SIGNALS FROM AS LOW AS -104dBm. THIS IS BELOW THE RANGE OF YOUR RSSI INDICATOR. USE A SPECTRUM ANALYZER TO LOCATE YOUR SIGNAL

If you find that you cannot detect any cellular signals using the RSSI indicator then you must use an alternative method to locate the signal.

If you fail to locate a signal then you have the following possibilities.

- 1) There is no cellular service.
- 2) Faulty coax, connectors or antenna.
- 3) Insufficient antenna separation, (vertical separation/ horizontal separation)
- 4) Aimed to a competitor's cell tower which does not service your cellular phone. This may show full power on your cellular phone but will not connect to the service.

FOR TECHNICAL ASSISTANCE INSTALLING YOUR REPEATER PLEASE CONTACT:

Telcosat Inc,
Calgary, Alberta,
Canada.
T2E 7E4
403 291 4031
Fax 403 291 3059
Email: technicalsupport@telcosat.com
NOTE: Local time, Central Mountain Time. (-7 GMT)

CHAPTER 4 WARRANTY AND REPAIR

4.1 WARRANTY

Your Telcosat Repeater is guaranteed against manufacturers defects for 120 days. Telcosat Inc retains the right to decide if the fault/defect is a manufacturers defect. Telcosat Inc will not accept liability for any damage caused through improper use or poor installation practices.

4.2 Limited Warranty

Hardware. Telcosat Inc, or any subsidiary selling the Product (RPT9000 Cellular Repeater) warrants that commencing from the date of shipment to Customer (and in case of resale by a Telcosat Inc reseller, commencing not more than ninety (120) days after original shipment by Telcosat Inc), and continuing for a period of the longer of (a) ninety (120) days or (b) the period set forth in the Warranty Card accompanying the Product (if any), the Hardware will be free from defects in material and workmanship under normal use. The date of shipment of a Product by Telcosat Inc is set forth on the packaging material in which the Product is shipped. This limited warranty extends only to the original user of the Product. Customer's sole and exclusive remedy and the entire liability of Telcosat Inc and its suppliers under this limited warranty will be, at Telcosat Inc or its service center's option, shipment of a replacement within the warranty period

and according to the replacement process described in the Warranty Card (if any), or if no Warranty Card, as described, or a refund of the purchase price if the Hardware is returned to the party supplying it to Customer, freight and insurance prepaid. Telcosat Inc replacement parts used in Hardware replacement may be new or equivalent to new. Telcosat Inc obligations hereunder are conditioned upon the return of affected Hardware in accordance with Telcosat Inc or its service center's then-current Return Material Authorization (RMA) procedures.

EXCEPT AS SPECIFIED IN THIS WARRANTY, ALL EXPRESS OR IMPLIED CONDITIONS, REPRESENTATIONS, AND WARRANTIES INCLUDING, WITHOUT LIMITATION, ANY IMPLIED WARRANTY OR CONDITION OF MERCHANTABILITY, FITNESS FOR A PARTICULAR PURPOSE, NON-INFRINGEMENT, SATISFACTORY QUALITY, NON-INTERFERENCE, ACCURACY OF INFORMATIONAL CONTENT, OR ARISING FROM A COURSE OF DEALING, LAW, USAGE, OR TRADE PRACTICE, ARE HEREBY EXCLUDED TO THE EXTENT ALLOWED BY APPLICABLE LAW AND ARE EXPRESSLY DISCLAIMED BY TELCOSAT INC, ITS SUPPLIERS AND LICENSORS. TO THE EXTENT AN IMPLIED WARRANTY CANNOT BE EXCLUDED, SUCH WARRANTY IS LIMITED IN DURATION TO THE EXPRESS WARRANTY PERIOD. SOME STATES OR JURISDICTIONS DO NOT ALLOW LIMITATIONS ON HOW LONG AN IMPLIED WARRANTY LASTS, THE ABOVE LIMITATION MAY NOT APPLY. THIS WARRANTY GIVES CUSTOMER SPECIFIC LEGAL RIGHTS, AND CUSTOMER MAY ALSO HAVE OTHER RIGHTS WHICH VARY FROM JURISDICTION TO JURISDICTION. This disclaimer and exclusion shall apply even if the express warranty set forth above fails of its essential purpose.

Restrictions. This warranty does not apply if the Product or any other equipment upon which the Product is authorized to be used (a) has been altered, except by Telcosat Inc, (b) has not been installed, operated, repaired, or maintained in accordance with instructions supplied by Telcosat Inc, (c) has been subjected to abnormal physical or electrical stress, misuse, negligence, accidents forces of nature, earthquakes, lightning strikes, vandalism, and civil unrest.

CHAPTER 5.

Storage of Equipment

When storing your equipment you must place the unit in a dry location, away from direct sun exposure and take measures to prevent moisture/condensation build up in your repeater enclosure.

Silica Gel bags should be placed inside the enclosure to absorb moisture. The door on the enclosure should be closed and sealed with weather proof tape to ensure an air tight enclosure.

The silica gel bags should be changed /inspected at regular intervals to ensure proper functionality of the material.

You are strongly advised to seek the advice of a professional company that has expertise in long term preservation techniques of electronic equipment.

Maximum storage temperatures of your Telcosat Repeater is +50c (122F)

Minimum storage temperature of your Telcosat Repeater is -40c (-40F)

APPENDIX A

TECHNICAL SPECIFICATIONS

Specifications for the Telcosat Repeater system CDMA/GSM Model RPT9000

Frequency Range:	Down link 824-849MHz / Up-link 869-894MHz
Overall systems Gain	(3dB Pass Band):110dB min. for 15db S/N
Pass band ripple:	+/- 2.5dB max. within 3dB Pass Band
Channel ripple:	.2dB max.
Group Delay Variation	90% of 3db Bandwidth typical: 65 nsec
Absolute Delay:	Less then 2. Micro sec.
Phase linearity	90% of 3 dB Bandwidth: typical 9.2 deg
Rx Noise figure @ maximum Gain:	3.7dB typical
IMD 2 tone :	51 dBc typical
IMD 4 tone:	48 dBc typical
Power output @ 1dB gain compression:	+ 30dBm RMS (up and down link)
Antenna Impedance Rx and TX :	Z= 50 ohms
Max SWR in/out:	1.5 to 1 max
Manual Gain Control user enable:	50dB total in 2db steps
Spurious outputs:	55dBc max
Power Supply:	28VDC/140Watts or 90 to 260 AC / 150 Watts consumption
Operating Temperature	-20 to+60 C
RF Connectors:	N- Type Female
Mechanical Specifications:	Size: 14.5" x 16.5" x 11.5" 36 x 41 x 29 cm
Weight:	40 pounds/ 20Kg typical
Enclosure type:	NEMA 4A, 12

Table 1

Nominal Pass-band Gain dB= 95dB
 Nominal band width Uplink 824/849 MHz = 25MHz
 Nominal band width Down-Link 869/894MHz = 25MHz
 Input and Output Antenna Impedance = 50 ohms
 Rated mean out-put power = +30dBm

NOTE RULE: RSS-133 section 5.3

The manufacturers rated output power of this equipment is for single carrier operation. For situations when multiple carrier signals are present, the rating would have to be reduced by 3.5dB, especially where the out-put signal is re-radiated and can cause interference to adjacent band users. This power reduction is to be by means of input power or gain reduction and not by an attenuator at the out-put device

FCC/IC RF Exposure Requirements

The antenna(s) used for this transmitter must be installed to provide a separation distance of at least 65.9 cm (25.94 inches) from all persons, and must not be co-located or operating in conjunction with any other antenna or transmitter.

Any modifications to this device will void FCC and IC approvals

APPENDIX B RETURNED GOODS PROCEDURE

B1. Technical Information

Contact Telcosat Inc or your supplier to determine whether or not an item should be returned for repair.

Contact Telcosat Inc 403 291 4031 or email, technicalsupport@telcosat.com

B2. Return Identification

Please provide the following information with each repair.

1. Date of requested repairs.
2. Customer name with full address for returning goods
3. Contact person responsible for returning the product for repairs
4. Client telephone number
5. Serial number (serial number is located on the exterior heat sink)
6. Original purchase date
7. Reason for return.

B3. Shipping Procedure

Ship all returned goods PREPAID to the following address:

Product Repairs,

Telcosat Inc,

Bay 116 1919 – 27th Avenue NE,

Calgary, Alberta,

Canada. T2E 7E4

Telephone 403 291 4031

Fax 403 291 3059

Email: technicalsupport@telcosat.com

Your commercial invoice must state REPAIR/RETURN. Failure to provide proper Commercial Invoices may result in taxes and duties which will be charged back to the client.

B4. Return Shipments

All returned shipments will be sent PREPAID, to the customer's indicated address.

Any extra packaging material will be charged back to the client.

B5. Repair / Return Status

Under normal circumstances defective items will be replaced repaired with in 5 working business days of receipt.

Telcosat Inc will inspect and test your repeater in a lab environment. Upon completion of the inspection a written estimate will be provided to the client. A minimum charge of \$500.00 will be charged to the client to cover the cost of inspection and testing plus minor repairs.

