

# BACnet Integration Manual for TB7600 Series Thermostats

**REFERENCE MANUAL**

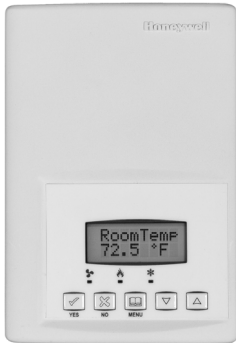

**TB7600 Series  
Thermostat**



**TB7600 Series  
Thermostat with  
Occupancy Sensor**

The TB7600 thermostats are also compatible with the Honeywell PIR occupancy sensor covers. Thermostats equipped with a PIR cover provide advanced active occupancy logic, which will automatically switch occupancy levels from Occupied to Unoccupied as required by local activity being present or not. This advanced occupancy functionality provides advantageous energy savings during occupied hours without sacrificing occupant comfort. All thermostats can be ordered with or without a factory installed PIR cover.

## More Information

The additional following documentation is available on <http://customer.honeywell.com>:

- TB7600 Series Installation Instructions (form number 62-2016).
- TB7600 Series with Humidity Control Installation Instructions (form number 62-2017).
- The PIR Application Guide for TB7600 Series (form number 63-4525).

## PRODUCT OVERVIEW

The TB7600 PI thermostat family is specifically designed for single stage and multi-stage control of heating/cooling equipment such as rooftop and self-contained units. The TB7600 Series are communicating thermostats with models available in BACnet<sup>®</sup> MS/TP and ZigBee<sup>®</sup> wireless mesh protocols and can be easily integrated into a WEBS-AX building automation system based on the NiagaraAX<sup>®</sup> platform. The product features an intuitive, menu-driven, backlit LCD display, which walks users through the programming steps, making the process extremely simple. Accurate temperature control is achieved due to the product's PI time proportional control algorithm, which virtually eliminates temperature offset associated with traditional, differential-based thermostats.

## Contents

Product Overview .....	1
Compatibility .....	2
Tips and Things You Need to Know .....	2
Wiring guidelines .....	3
Network Configuration .....	4
Network Adapter .....	6
Integration .....	7
Troubleshooting .....	11
Appendix .....	12
TB7600 Series Protocol Implementation	
Conformance Statement (PICS) .....	12
BACnet Objects Supported .....	13



# COMPATIBILITY

Honeywell TB7600 Series thermostat compatibility information is provided in Table 1.

**Table 1. TB7600 Thermostat Compatibility Information**

WEBS-AX Controller	Thermostats Per Controller*	WEBStation-AX
WEB-2xx	126	3.0 or later
WEB-6xx	126	3.0 or later
WEB-7xx	126	3.5

\* 128 total devices supported. One node used by controller and one for a repeater. A repeater is required if more than 64 devices are on a bus.

## TIPS AND THINGS YOU NEED TO KNOW

- Each TB7600 Series thermostat is delivered from the factory with the default MAC address set at 254 (referred to as the Com Addr in the parameters at the thermostat). At this value, BACnet communication is NOT active and the device will not participate in the token pass either. The local LED status for the communication adapter at this point is one short flash only. To enable BACnet communication, set the local MAC address configuration property of the thermostat to any valid value from 0 to 127.
- After the initial configuration of your device and if your BAS allows you to remove objects, we suggest that you remove all the configuration objects to prevent unnecessary polling of unused objects and to help speed up the network.
- All configuration objects are available and accessible locally from the device itself using the local configuration routine. Please refer to the TB7600 Series (form number 62-2016) or TB7600 Series with Humidity Control (form number 62-2017) installation instructions for details.
- In its default mode of operation, the device will automatically match its baud rate to the baud rate of the network. Automatic baud rate detection will occur when the MS/TP communication port is initialized (on power up). If the network speed is changed, the device will keep listening at the previously detected speed for 10 minutes before resuming auto-bauding. Re-powering the devices will force right away auto-bauding.
- If the device should go off-line, the following binded thermostat parameters will be released:
  - Room Temperature
  - Outdoor Temperature
  - Occupancy
- The BACnet Data Link layer has two key parameters: the device object name and the device object ID. The device object name must be unique from any other BACnet device object name on the BACnet network (i.e. not just the MS/TP sub-network). The device object ID must be unique from any other BACnet device object ID on the entire BACnet network (i.e. not just the MS/TP sub-network).
- On models with scheduling, time synchronization can be made through a network even if the thermostat does not support the full date. Therefore, the device cannot claim conformance to the DeviceManagement – TimeSynchronization - B (DM-TS-B) service. The device object does not have the Local\_Time or Local\_Date properties.
- Programmable models (with scheduling) are intending for stand-alone applications where the thermostat may be added to the network at a later time. Once a programmable thermostat is added to a network all schedule must be done through the Workbench. Local control of network settings is not supported. To hide the scheduling option from the local thermostat use one of the BIs and set to Rem NSB if a BI is not being used.
- Device Name and Device ID properties are writable in Honeywell device object. Both properties can be renamed from any BACnet network management tool as long as the tool itself gives access to write to these properties.

# WIRING GUIDELINES

## Overview

Honeywell uses EIA-485 as the physical layer between their devices and supervisory controllers

For clarity we will use the term “Device” to represent any product with an active EIA-485 network connection, including Honeywell and non-Honeywell thermostats.

**Table 2. Summary of Specifications for a Honeywell EIA-485 Network**

Parameter	Details
<b>Media</b>	Twisted pair 22AWG-24 AWG, shielded recommended
<b>Characteristic Impedance</b>	100-130 ohms
<b>Distributed capacitance</b>	Less than 100 pF per meter (30 pF per foot)
<b>Maximum length per segment</b>	1200 meters (4000 feet)
<b>Polarity</b>	Polarity sensitive
<b>Multi-drop</b>	Daisy-chain (no T connections)
<b>Terminations</b>	<p><b>TB7600, TB7300, and/or TB7200 Series thermostats are installed at both ends of the MS/TP network:</b> 120 Ohms resistor should be installed at each end. To reduce issues with other BACnet devices we recommended keeping like devices on the same bus. TB7600, TB7300 and TB7200 Series thermostats can be installed on the same bus.</p> <ol style="list-style-type: none"> <li><b>A TB7600, TB7300, or TB7200 device is installed at one end of the MS/TP network and another device is installed at the other end:</b> Install an End-Of-Line resistor value that matches the other device's instructions regarding the End-Of-Line resistors</li> <li><b>Other devices are installed at both ends of the MS/TP network:</b> Follow the other device's instructions regarding the End-Of-Line resistors.</li> </ol>
<b>Maximum number of nodes per segment</b>	64 (Honeywell devices only)
<b>Maximum number of nodes per network</b>	128
<b>Baud rate</b>	9600, 19200, 38400, 76800 (Auto detect)

## Cable Type

Honeywell recommends the use of balanced 22-24 AWG twisted pair with a characteristic impedance of 100-130 ohms, capacitance of 30 pF/ft or lower. A braided shield is also recommended.

## Impedance

A value based on the inherent conductance, resistance, capacitance and inductance that represent the impedance of an infinitely long cable. The nominal impedance of the cable should be between 100Ω and 120Ω. However using 120Ω will result in a lighter load on the network.

## Capacitance (pF/ft)

The amount of equivalent capacitive load of the cable, typically listed in a per foot basis. One of the factors limiting total cable length is the capacitive load. Systems with long lengths benefit from using low capacitance cable (i.e. 17pF/ft or lower).

# NETWORK CONFIGURATION

EIA-485 networks use a daisy chain configuration. A daisy chain means that there is only one main cable and every network device is connected directly along its path.

Fig. 1 illustrates two improper network configurations and the proper daisy chain configuration.

Other methods of wiring an EIA-485 network may give unreliable and unpredictable results. There are no troubleshooting methods for these types of networks. Therefore, a great deal of site experimentation may have to be done, making this a difficult task with no guarantee of success. Honeywell will only support daisy chain configurations.

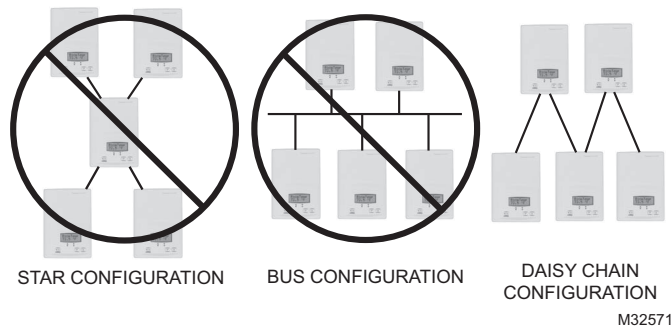

**Fig. 1. Three different network configurations: star, bus, and daisy chain. Only the daisy chain configuration is correct for an EIA-485 network.**

## Maximum Number of Devices

A maximum of 64 nodes is allowed on a single daisy chain segment. A node is defined as any device (controller, thermostat, repeater) connected to the RS485 network. Terminators do not count as a node.

NOTE: Biasing is not required with this series of devices.

To determine the number of nodes on a network, add the following:

- One node for each device, including controller
- One node for each repeater on the chain

For the example in Fig. 2, we have one node for the controller, plus 4 for the thermostats, for a total of 5 nodes.

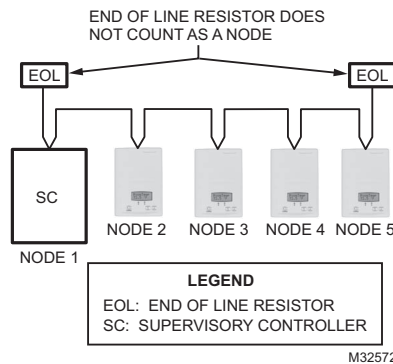

**Fig. 2. Five nodes network example.**

If you have more than 64 devices, then repeaters are required to extend the network.

## Maximum Cable Length

The maximum length of a chain is related to its transmission speed. The longer the chain, the slower the speed. Using proper cable, the maximum length of an EIA-485 daisy chain is 4000-ft (1200 m). This will only work reliably for data rates up to 100,000 bps. TB7600 thermostats' maximum data rate is 76,800 bps.

If you require a maximum network length of more than 4000 feet, then repeaters are required to extend the network.

## EIA-485 Repeaters

If you have more than 64 devices, or require a maximum network length of more than 4000 feet, repeaters are required to extend the network. The BASRT-B repeater by Contemporary Controls can be used if a repeater is needed. The best configuration is to daisy chain the repeaters to the controller. From each of these repeaters, a separate daisy chain will branch off. Fig. 3 demonstrates a valid use of repeaters in an EIA-485 network.

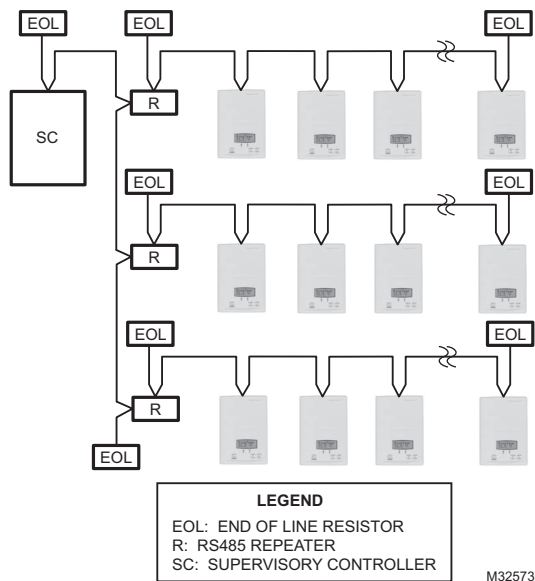

**Fig. 3. Correct usage – repeaters are daisy-chained to the supervisory controller and separate daisy chains branch from each repeater.**

Do not install repeaters in series, as this may result in network reliability problems. Fig. 4 demonstrates an incorrect use of a repeater in an EIA-485 network.

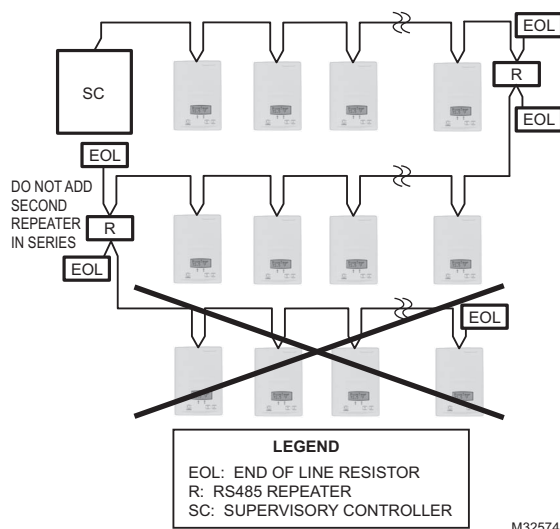

**Fig. 4. Incorrect usage – the second repeater in series may result in an unreliable system.**

## End Of Line (EOL) Resistors

MS/TP network must be properly terminated. For daisy chain configurations, you must install an EOL resistor at each end of the daisy chain. Depending on your MS/TP network configuration, the resistance value of the EOL resistor may change:

- **TB7600, TB7300, and/or TB7200 thermostats are installed at both ends of the MS/TP network:**  
120 Ohms resistor should be installed at each end.
- **A TB7600, TB7300, or TB7200 device is installed at one end of the MS/TP network and another device is installed at the other end:**  
Install an End-Of-Line resistor value that matches the other device's instructions regarding its EOL resistor value;
- **Other devices are installed at both ends of the MS/TP network:**  
Follow the other device's instructions regarding its EOL resistor value.

## NETWORK ADAPTER

The polarity of the connection to the cable is important. From one module to the other it is important that the same color wire be connected to "plus" or "+" and the other color wire be connected to the "minus" or "-". Fig. 5 shows the proper MS/TP connections and the location of the Status LED. This Status LED may help to troubleshoot network problems.

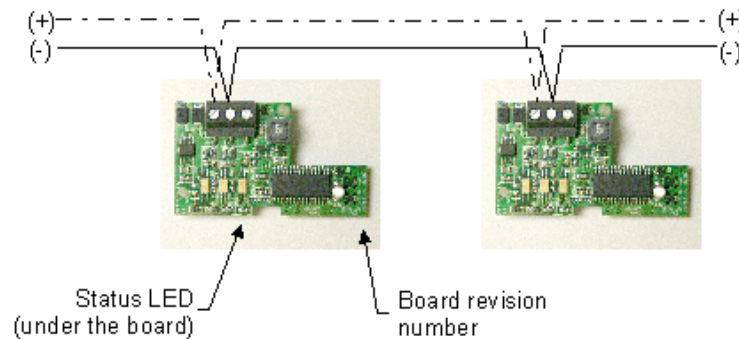

**Fig. 5. Correct MS/TP connections and location of a Status LED on a BACnet module**

**IMPORTANT NOTE:** The Ref terminal should **NEVER** be used to wire shields. The 2 shields from each feed of the network connection to a thermostat should be wired together in the back of the thermostat and properly protected to prevent any accidental connection to the ground.

The joined shield connection should then be grounded at a **SINGLE** point on the whole segment. More than one ground connection to a shielded wire may induce ground loop noises and affect communication.

## Network Adapter Status LED

Table 3 shows the different possibilities with the Status LED behavior of the BACnet module.

**Table 3. Status LED condition and possible solutions**

Condition of the Status LED	Possible Cause	Solution
1 short blink	BACnet communication NOT active at default MAC address = 254	Change MAC address to another value from 0 to 127
2 short blinks (no wires connected to the module)	The BACnet module is recognized on the thermostat and has been installed on the right thermostat model	N/A
2 short blinks (wires connected to the module)	Module is not at the same baud rate as the network	Power off and on the thermostat
2 short blinks and a longer blink (wires connected to the module)	The module has detected the presence of a network	N/A
Right after power is applied: 2 long blinks and then no blinking	Polarity has been reversed at the module	Reverse polarity at the module

## INTEGRATION

This section provides compatibility and programming information useful when setting up TB7600 Series thermostats on a WEBS-AX building automation system.

### Global Commands

The following figure shows which objects from the thermostat can be monitored and commanded from the BAS front-end.

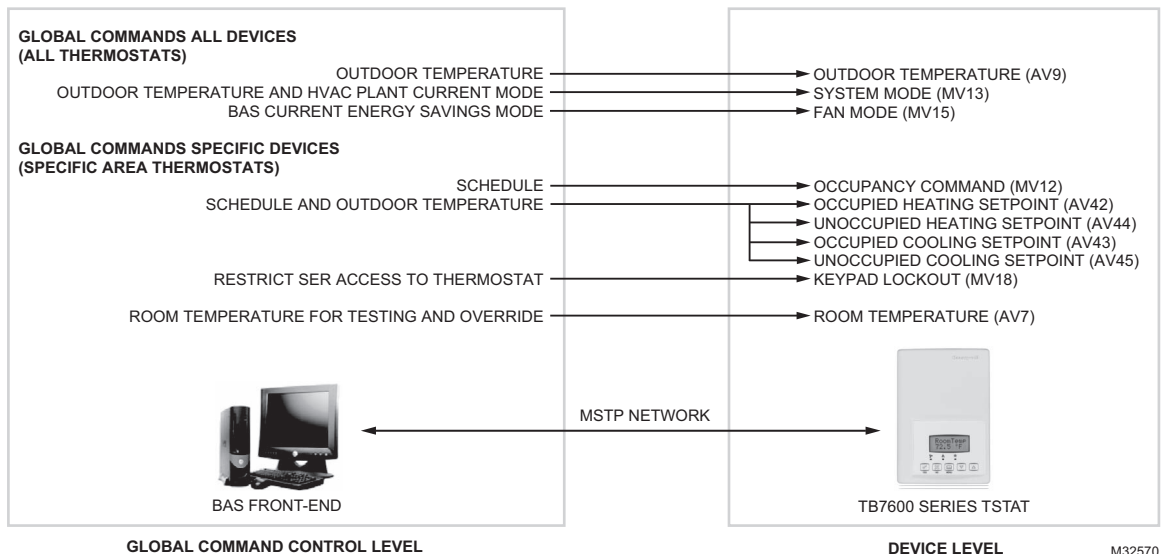

**Fig. 6. Global commands from a BAS front-end to a TB7600 series thermostat.**

## Typical Graphical User Interface (GUI) Objects

The following objects should be typically used in a GUI:

- Room Temperature (AV7);
- Occupied and Unoccupied Heat Setpoints (AV 42 and AV44);
- Occupied and Unoccupied Cool Setpoints (AV 43 and AV45);
- Outdoor Temperature (AV9);
- Supply Temperature (AI16) (If available);
- Occupancy Command (MV12);
- Effective Occupancy (MV34);
- System Mode RTU (MV14) or System Mode HPU (MV13);
- G Fan (BI25);
- Y1 Cool (BI26);
- Y2 Cool (BI27);
- W1 Heat (BI28);
- W2 Heat (BI29) or Reversing Valve (BI30);
- Economizer Output (AV22) (if available);
- Aux (BI24);
- DI 1 Status (BI31);
- DI 2 Status (BI 32);
- Frost Alarm (BI36) (if available);
- Filter Alarm (BI38) (if available);
- Service Alarm (BI39) (if available);
- Fan Lock Alarm (BI40) (if available)

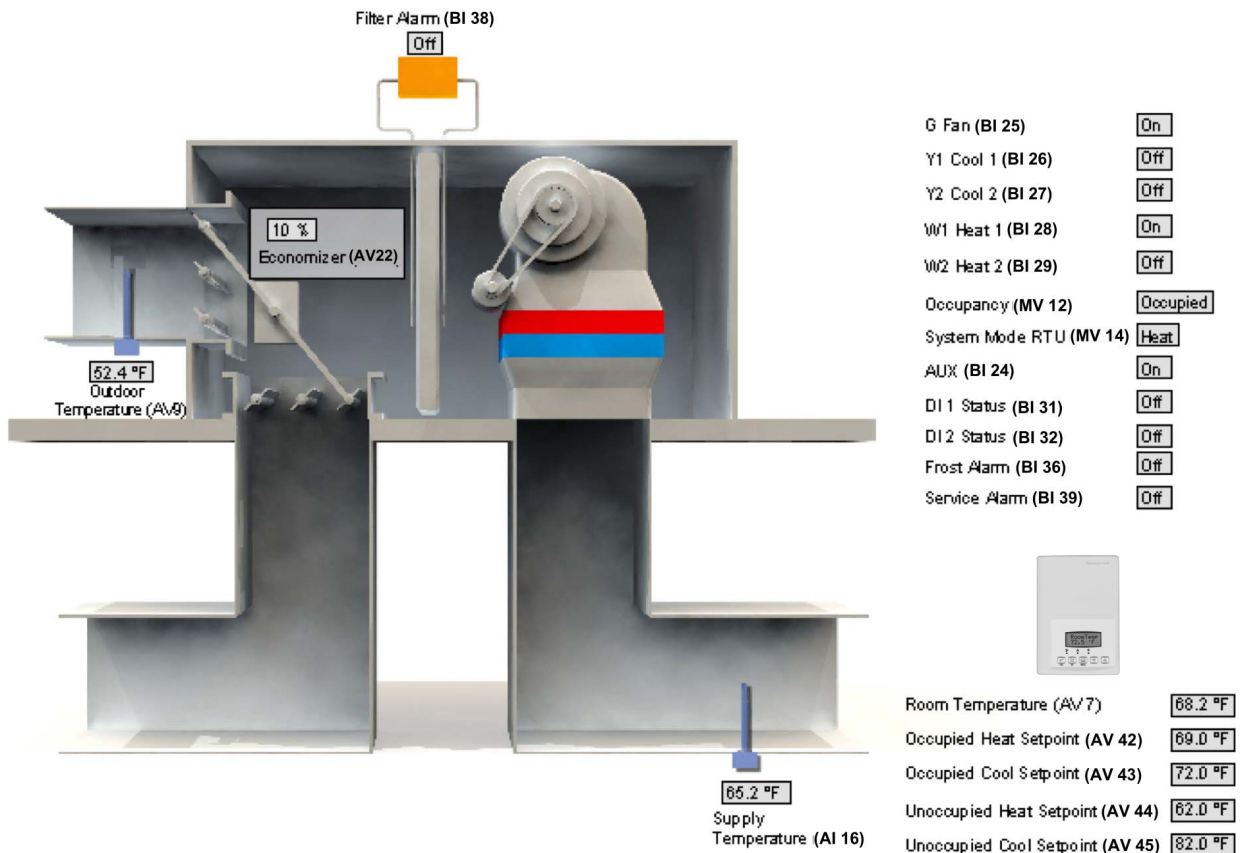

Fig. 7. Typical GUI for a TB7605B5014B with Economizer control.



## Recommended Configuration Objects

The following objects and group objects should be typically used for configuration purposes. If your BAS allows you to remove objects from your database, Honeywell recommends removing all configuration objects once your setup is complete. This will prevent unnecessary polling of unused objects and will help speed up the network.

- General Options 1 Group GRP 46 and its complete list of objects;
- General Options 2 Group GRP 58 and its complete list of objects;
- Programmable Model Configuration Options Group GRP 69 and its complete list of objects;
- Stages Configuration Options Group GRP 72 and its complete list of objects;
- Economizer Model Configuration Option Group GRP 76 and its complete list of objects;
- Heatpump Model Configuration Option Group GRP 81 and its complete list of objects;
- Dehumidification Model Configuration Option Group GRP 87 and its complete list of objects;
- Humidification Model Configuration Option Group GRP 94 and its complete list of objects;

## Default Device Name and default Device ID

Default Device Name is set to: Model number – MAC:

- Where MAC is the current MAC address of the device.
- Where Model number is Honeywell part number.

The device name will be upgraded as soon as there is a change to the device MAC address.

- Default Device ID is set to: 76000 + MAC
- Where MAC is the current MAC address of the device.

The device ID will also be upgraded as soon as there is a change to the device's MAC.

For example, when a TB7600B5x14B thermostat with a MAC address of 63 is connected to a network, its default Device Name will be TB7600B5x14B-63 and its default Device ID will be 76063.

Device Name and Device ID properties are writable in Honeywell device object. Both properties can be renamed from any BACnet network management tool as long as the tool itself can write to these properties.

## Integrating Honeywell Devices on an MS/TP Network

Before doing any BACnet integration, make sure to have Honeywell PICS (Protocol Implementation Conformance Statement).

This PICS document lists all the BACnet Services and Object types supported by a device and can be found at <http://customer.honeywell.com>.

The TB7600 Series does not support the COV service. COV reporting allows an object to send out notices when its Present-Value property is incremented by a pre-defined value. Since this is not supported at Honeywell end, special attention should be given to the polling time settings at the Supervisory Controller and Workstation level when using a graphic interface or an application program to read or write to a Honeywell object.

## Graphical interfaces

For example, some graphic interface might poll every data linked to the graphic page on a COV basis. If the 3<sup>rd</sup> party device does not support COV, the graphic interface then relies on a pre-configured polling interval, which is usually in hundredths of milliseconds. Any device containing a monitored object could be subject to network traffic congestion if such a polling interval is used. Honeywell strongly recommends a polling interval of 5 seconds minimum for any graphic interface. This becomes even more critical in area graphics where a single representation might poll many devices. If proper poll rate is not respected, devices may be reported offline by certain front end by saturating the traffic handling capacity of BACnet MS/TP without COV subscription.

## Free programmed object or loops

As for the application program, you might want to read and write any MS/TP data on an “If Once” basis or a “Do Every” loop basis instead of reading or writing to a 3<sup>rd</sup> party device’s object directly in the program. Otherwise, any read or write request will occur at the Supervisory Controller’s program scan rate, which might as well be in hundredths of milliseconds. This can easily bog down a network as single commands can be sent to all ASC devices down the MS/TP trunks every hundredth of milliseconds.

Programs writing to the devices should have a structure similar to the following:

<pre>If Once Schedule = On then   MV11 = Occupied End if If Once Schedule = Off Then   MV11 = Unoccupied End If</pre>	OR	<pre>Do Every 5 min.   If Schedule = On Then     MV11= Occupied   Else     MV11 = Unoccupied   End If End Do</pre>
---	----	--

## Retries and Timeouts

Another thing to look for in a BACnet integration is the Device object of the Supervisory Controller (and the Operator’s Workstation). This object contains the 2 following required properties: Retry Timeout and Number of APDU Retries.

1. The Retry Timeout property specifies the time between re-transmissions if the acknowledgement has not been received. When you are experiencing problems with controllers dropping off-line, increasing this value may help.
2. The Number of APDU Retries property specifies the number of times unsuccessful transmissions will be repeated. If the receiving controller has not received the transmission successfully after this many attempts, no further attempts will be made.

For example, if one of the thermostats does not reply to a Supervisory Controller (SC) request, and the SC’s Retry Timeout is set to 2000 msec and the Number of APDU Retries is set to 1 (still at the SC level), then the SC will send one other request, 2 sec later. If the MS/TP device does not reply, it will be considered Off-line by the workstation.

So having a Retry Timeout value of 10000 msec and a Number of APDU Retries property set to 3 at the SC level may prevent device from dropping Off-line. These properties should also be changed at the Workstation level since the workstation will likely issue requests to any MS/TP devices when the graphics are used.

## TROUBLESHOOTING

Error / Trouble Condition	Possible Cause	Solution
<b>Thermostat does not come online</b>	Two or more controllers have the same MAC address.	Modify each duplicate address to a unique number.
	The MS/TP network has too many devices.	Do not exceed the maximum number of devices and maximum length allowed by the EIA-485 specifications.
	Too many devices were installed without any repeaters.	Repeaters need to be installed as specified in this document.
	The MS/TP cable runs are broken	Locate the break and correct wiring
	MS/TP connections at the module were reversed	Respect polarity of the wires on a MS/TP network.
	The thermostat does not have power	Apply power to the thermostat

## APPENDIX A: BACNET OBJECTS

### TB7600 SERIES PROTOCOL IMPLEMENTATION CONFORMANCE STATEMENT (PICS)

**Vendor Name:** Honeywell

**Vendor ID:** 140

**Product Name:** TB7600 Thermostat Series

**Product Model Number:** TB7600A5x14B, TB7614B5x 14B, TB7605B5x 14B, TB7607B5x14B, TB7600H5x 14B, TB7652A5x 0B, TB7652B5x 14B, TB7656B5x 14B, TB7657B5x14B and TB7652H5x0B.

#### Product Description

The TB76xx series BACnet communicating thermostat has been specifically designed for RTU and heatpump applications to be monitored on a BACnet MS-TP® network.

#### Supported BACnet Services

The BACnet communicating thermostat meets all requirements for designation as an Application Specific Controller (B-ASC). The BACnet thermostat series supports the following BACnet Interoperability Building Blocks (BIBBs).

Application Service	Designation
Data Sharing – Read Property - B	DS-RP-B
Data Sharing – Read Property Multiple - B	DS-RPM-B
Data Sharing – Write Property - B	DS-WP-B
Device Management - Device Communication Control - B	DM-DCC-B
Device Management – Dynamic Device Binding - B	DM-DDB-B
Device Management – Dynamic Object Binding - B	DM-DOB-B

NOTE: The thermostat does not support segmented requests or responses.

NOTE: Time synchronization can be made through a network even if the thermostat does not support the full date. Therefore, the device cannot claim conformance to the DeviceManagement – TimeSynchronization - B (DM-TS-B) service. The device object does not have the Local\_Time or Local\_Date properties.

# BACNET OBJECTS SUPPORTED

## Device Objects

Table 4. Device Objects

Object Name	Type and Instance	Object Property	Thermostat Parameter
TB76xxX5x14B	Device	Object_Identifier Property 75 (R,W)	Unique ID number of a device on a network
		Object_Name Property 77 (R,W)	Unique name of a Device on a network
		Model Name Property 70 (R)	Thermostat Model number
		Firmware Revision Property 44 (R)	Current BACnet firmware revision used by the thermostat
		Protocol Version Property 98 (R)	Current BACnet firmware protocol version Default is Version 1
		Protocol Revision Property 139 (R)	Current BACnet firmware protocol revision Default is Version 2
		Max ADPU Length Property 62 (R)	Maximum ADPU Length accepted Default is 244
		ADPU Timeout Property 10 (R)	ADPU timeout value Default is 60 000 ms
		Application-Software-Version Property 12 (R)	Thermostat base application software version Default is based on current released version
		Max_Master (R,W)	Maximum master devices allowed to be part of the network. 0 to 127, default is 127
		MS/TP_Address Property 1001 (R,W)	BACnet MS-TP MAC Address. Proprietary attribute. Default is as assigned by configuration
		MS/TP_Baud_Rate Property 1002 (R,W)	BACnet MS-TP Baud-Rate. Proprietary attribute. Range is: 1 = 9.6 KBps, 2 = 19.2 KBps, 3 = 38.4 KBps, 4 = 76.8 KBps and 5 = Auto Baud Rate. Index 5 is Write only. Reading attribute will state current Baud rate used. Writing index 1 to 4 will fix the Baud rate to the desired value.

## Objects Table

Table 5. Objects

Object Name	Type and Instance	Object Property	TB7600A5x14B	TB7652A5x14B	TB7600B5x14B	TB7652B5x14B	TB7605B5x14B	TB7656B5x14B	TB7607B5x14B	TB7657B5x14B	TB7600H5x14B	TB7652H5x14B
Room Temperature	AV 7	Present_Value (R,W)	√	√	√	√	√	√	√	√	√	√
Room Temp Override	BV 8	Present_Value (R,W)	√	√	√	√	√	√	√	√	√	√
Outdoor Temperature	AV 9	Present_Value (R,W)	√	√	√	√	√	√	√	√	√	√
Outdoor Temp Override	BV 10	Present_Value (R,W)	√	√	√	√	√	√	√	√	√	√
Room Humidity	AV 11	Present_Value (R)							√	√		
Occupancy Command	MV 12	Present_Value (R,W)	√	√	√	√	√	√	√	√	√	√
System Mode HP	MV 13	Present_Value (R,W)									√	√
System Mode RTU	MV 14	Present_Value (R,W)	√	√	√	√	√	√	√	√		
Fan Mode	MV 15	Present_Value (R,W)	√	√	√	√	√	√	√	√	√	√
Supply Temp	AI 16	Present_Value (R)	√	√	√	√	√	√			√	√
Supply RH	AV 17	Present_Value (R)							√	√		
Keypad Lockout	MV 18	Present_Value (R,W)	√	√	√	√	√	√	√	√	√	√
Control Output	GR 19	Present_Value (R)	√	√	√	√	√	√	√	√	√	√
PI Heating Demand	AV 20	Present_Value (R)	√	√	√	√	√	√	√	√	√	√
PI Cooling Demand	AV 21	Present_Value (R)	√	√	√	√	√	√	√	√	√	√
Economizer Output	AV 22	Present_Value (R)					√	√				
Controller Status	GRP 23	Present_Value (R)	√	√	√	√	√	√	√	√	√	√
AUX	BI 24	Present_Value (R)	√	√	√	√	√	√	√	√	√	√
G Fan	BI 25	Present_Value (R)	√	√	√	√	√	√	√	√	√	√
Y1 Cool	BI 26	Present_Value (R)	√	√	√	√	√	√	√	√	√	√
Y2 Cool	BI 27	Present_Value (R)			√	√	√	√	√	√	√	√
W1 Heat	BI 28	Present_Value (R)	√	√	√	√	√	√	√	√	√	√
W2 Heat	BI 29	Present_Value (R)			√	√	√	√	√	√		
Reversing Valve	BI 30	Present_Value (R)									√	√
DI 1 Status	BI 31	Present_Value (R)	√	√	√	√	√	√	√	√	√	√
DI 2 Status	BI 32	Present_Value (R)	√	√	√	√	√	√			√	√
Local Motion	BI 33	Present_Value (R)	√	√	√	√	√	√	√	√	√	√
Effective Occupancy	MV 34	Present_Value (R)	√	√	√	√	√	√	√	√	√	√
Controller Alarms	GRP 35	Present_Value (R)	√	√	√	√	√	√	√	√	√	√
Frost Alarm	BI 36	Present_Value (R)	√	√	√	√	√	√	√	√	√	√
Clock Alarm	BI 37	Present_Value (R)		√		√		√		√		√
Filter Alarm	BI 38	Present_Value (R)	√	√	√	√	√	√	√	√	√	√
Service Alarm	BI 39	Present_Value (R)	√	√	√	√	√	√	√	√	√	√
Fan Lock Alarm	BI 40	Present_Value (R)	√	√	√	√	√	√	√	√	√	√
Temperature Setpoints	GRP 41	Present_Value (R)	√	√	√	√	√	√	√	√	√	√
Occupied Heat Setpoint	AV 42	Present_Value (R,W)	√	√	√	√	√	√	√	√	√	√
Occupied Cool Setpoint	AV 43	Present_Value (R,W)	√	√	√	√	√	√	√	√	√	√

Table 5. Objects

Object Name	Type and Instance	Object Property	TB7600A5x14B	TB7652A5x14B	TB7600B5x14B	TB7652B5x14B	TB7605B5x14B	TB7656B5x14B	TB7607B5x14B	TB7657B5x14B	TB7600H5x14B	TB7652H5x14B
Unoccupied Heat Setpoint	AV 44	Present_Value (R,W)	√	√	√	√	√	√	√	√	√	√
Unoccupied Cool Setpoint	AV 45	Present_Value (R,W)	√	√	√	√	√	√	√	√	√	√
General Options 1	GRP 46	Present_Value (R)	√	√	√	√	√	√	√	√	√	√
Temperature Scale	BV 47	Present_Value (R,W)	√	√	√	√	√	√	√	√	√	√
Heating Setpoint Limit	AV 48	Present_Value (R,W)	√	√	√	√	√	√	√	√	√	√
Cooling Setpoint Limit	AV 49	Present_Value (R,W)	√	√	√	√	√	√	√	√	√	√
Heating Lockout Temperature	AV 50	Present_Value (R,W)	√	√	√	√	√	√	√	√	√	√
Cooling Lockout Temperature	AV 51	Present_Value (R,W)	√	√	√	√	√	√	√	√	√	√
Deadband	AV 52	Present_Value (R,W)	√	√	√	√	√	√	√	√	√	√
Heating CPH	MV 53	Present_Value (R,W)	√	√	√	√	√	√	√	√	√	√
Cooling CPH	MV 54	Present_Value (R,W)	√	√	√	√	√	√	√	√	√	√
Frost Protection	BV 55	Present_Value (R,W)	√	√	√	√	√	√	√	√	√	√
Aux Contact	BV 56	Present_Value (R,W)	√	√	√	√	√	√	√	√	√	√
Menu Scroll	BV 57	Present_Value (R,W)	√	√	√	√	√	√	√	√	√	√
General Options 2	GRP 58	Present_Value (R)	√	√	√	√	√	√	√	√	√	√
Password Value	AV 59	Present_Value (R,W)	√	√	√	√	√	√	√	√	√	√
Power-up Delay	AV 60	Present_Value (R,W)	√	√	√	√	√	√	√	√	√	√
Temporary Occupancy Time	MV 61	Present_Value (R,W)	√	√	√	√	√	√	√	√	√	√
Fan Control	BV 62	Present_Value (R,W)	√	√	√	√	√	√	√	√	√	√
Anticycle	MV 63	Present_Value (R,W)	√	√	√	√	√	√	√	√	√	√
Fan Purge Delay	BV 64	Present_Value (R,W)	√	√	√	√	√	√	√	√	√	√
DI 1 Configuration	MV 65	Present_Value (R,W)	√	√	√	√	√	√	√	√	√	√
DI 2 Configuration	MV 66	Present_Value (R,W)	√	√	√	√	√	√			√	√
Proportional Band	MV 67	Present_Value (R,W)	√	√	√	√	√	√	√	√	√	√
Unoccupied Time	AV 68	Present_Value (R,W)	√	√	√	√	√	√	√	√	√	√
Programmable Model Configuration Options	GRP 69	Present_Value (R)		√		√		√		√		√
Progressive Recovery	BV 70	Present_Value (R,W)		√		√		√		√		√
Event Display	MV 71	Present_Value (R,W)		√		√		√		√		√
Stages Configuration Options	GRP 72	Present_Value (R)			√	√	√	√	√	√	√	√
Heating Stages	MV 73	Present_Value (R,W)			√	√	√	√	√	√		
Cooling Stages	MV 74	Present_Value (R,W)			√	√	√	√	√	√		
Heatpump Stages	MV 75	Present_Value (R,W)									√	√
Economizer Model Configuration Options	GRP 76	Present_Value (R)					√	√				

Table 5. Objects

Object Name	Type and Instance	Object Property	TB7600A5x14B	TB7652A5x14B	TB7600B5x14B	TB7652B5x14B	TB7605B5x14B	TB7656B5x14B	TB7607B5x14B	TB7657B5x14B	TB7600H5x14B	TB7652H5x14B
Economizer Changeover Setpoint	AV 77	Present_Value (R,W)					√	√				
Economizer Minimum Position	AV 78	Present_Value (R,W)					√	√				
Mechanical Cooling Enabled	BV 79	Present_Value (R,W)					√	√				
Mixed Air Setpoint	AV 80	Present_Value (R,W)					√	√				
Heatpump Model Configuration Options	GRP 81	Present_Value (R)									√	√
High Balance Point	AV 82	Present_Value (R,W)									√	√
Low Balance Point	AV 83	Present_Value (R,W)									√	√
Comfort Mode	BV 84	Present_Value (R,W)									√	√
Reversing Valve Configuration	BV 85	Present_Value (R,W)									√	√
Compressor Interlock	BV 86	Present_Value (R,W)									√	√
Dehumidification Model Configuration Options	GRP 87	Present_Value (R)							√	√		
RH Display	BV 88	Present_Value (R,W)							√	√		
Dehumidification RH Setpoint	AV 89	Present_Value (R,W)							√	√		
Dehumidification Hysterisis	AV 90	Present_Value (R,W)							√	√		
Dehumidification Low OA Lockout	AV 91	Present_Value (R,W)							√	√		
Dehumidification Lockout Functions	BV 92	Present_Value (R,W)							√	√		
Dehumidification Output Status	BI 93	Present_Value (R)							√	√		
Humidification Model Configuration Options	GRP 94	Present_Value (R)							√	√		
Humidification RH Setpoint	AV 95	Present_Value (R,W)							√	√		
Eff (Effective) Reset Humidification RH Spt (Setpoint)	AV 96	Present_Value (R)							√	√		
Humidification High Limit Spt (Setpoint)	AV 97	Present_Value (R,W)							√	√		
Low RH Setpoint	AV 98	Present_Value (R,W)							√	√		
Low Temp Reset RH Setpoint	AV 99	Present_Value (R,W)							√	√		
High Temp Reset RH Setpoint	AV 100	Present_Value (R,W)							√	√		
Humidifier Output	AV 101	Present_Value (R)							√	√		
Local Schedule	SCH 102	Present_Value (R,W)		√		√		√		√		√



## Standard Object Types Supported

Table 6. Standard Object Types Supported

Object Type	Supported Objects	Dynamically Creatable	Dynamically Deletable	Optional Properties Supported	Writable Properties
Analog Input	<input checked="" type="checkbox"/>	<input type="checkbox"/>	<input type="checkbox"/>	Reliability	Out_of_Service
Analog Value	<input checked="" type="checkbox"/>	<input type="checkbox"/>	<input type="checkbox"/>	Reliability	Present_Value <sup>a</sup> Out_of_Service <sup>a</sup> Object_Name <sup>b</sup>
Binary Input	<input checked="" type="checkbox"/>	<input type="checkbox"/>	<input type="checkbox"/>	Reliability Active_Text Inactive_Text	Out_of_Service
Binary Value	<input checked="" type="checkbox"/>	<input type="checkbox"/>	<input type="checkbox"/>	Reliability Active_Text Inactive_Text	Present_Value Out_of_Service
Device	<input checked="" type="checkbox"/>	<input type="checkbox"/>	<input type="checkbox"/>	Max_Master Max_Info_frames	Object_Identifier Object_name Max_Master
Group	<input checked="" type="checkbox"/>	<input type="checkbox"/>	<input type="checkbox"/>	N/A	N/A
Multi-state Value	<input checked="" type="checkbox"/>	<input type="checkbox"/>	<input type="checkbox"/>	Reliability States_Text	Present_Value Out_of_Service
Schedule	<input checked="" type="checkbox"/>	<input type="checkbox"/>	<input type="checkbox"/>	Weekly_schedule	Present_Value Weekly_Schedule

<sup>a</sup> The following AV's are defined as read only. When Out\_of\_Service properties is set to true, the Present\_Value if written is not derived from the application level of the thermostat.

- Room Humidity (AV11)
- PI Heating Demand (AV20)
- PI Cooling Demand (AV21)
- Economizer Output (AV22)
- Eff Reset Humidification RH Spt (AV96)
- Humidifier Output (AV101)

<sup>b</sup> Object\_Name property is writable for 1 object only :

- Room\_Temperature (AV7)

## Proprietary Properties

Table 7. Proprietary Properties

Property name	ID	BACnet Data type	Description
Major_Version	1000	CharacterString	The version number of the BACnet communications module. This is the hardware version number.
MS/TP_Address	1001	Unsigned	Display the MAC layer address of the module
MS/TP_Baud_Rate	1002	Unsigned	Display the communication baud rate of the module
Sensor_Offset	1005	REAL	Display the temperature or humidity calibration value. The range is –5.0 deg F to 5.0 deg F for a temperature and –15% to 15% for humidity.

## Property Value Range Restrictions for AI and AV objects

Table 8. Property Value Range Restrictions for AI and AV objects

Object name	Object Type and instance	Under range value	Over range value	Default value
Room Temperature	AV 7	-40°F (-40°C)	122°F (50°C)	N/A
Outdoor Temperature	AV 9	-40°F (-40°C)	122°F (50°C)	N/A
Room Humidity	AV 11	0%	100%	N/A
Supply Temp	AI 16	-40°F (-40°C)	122°F (50°C)	N/A
Supply RH	AV 17	0%	100%	N/A
PI Heating Demand	AV 20	0%	100%	N/A
PI Cooling Demand	AV 21	0%	100%	N/A
Economizer Output	AV 22	0%	100%	N/A
Occupied Heat Setpoint	AV 42	40°F (4.5°C)	90°F (32°C)	72°F (22°C)
Occupied Cool Setpoint	AV 43	54°F (12°C)	100°F (37.5°C)	75°F (24°C)
Unoccupied Heat Setpoint	AV 44	40°F (4.5°C)	90°F (32°C)	62°F (16.5°C)
Unoccupied Cool Setpoint	AV 45	54°F (12°C)	100°F (37.5)	80°F (26.5°C)
Heating Setpoint Limit	AV 48	40°F (4.5°C)	90°F (32°C)	90°F (32°C)
Cooling Setpoint Limit	AV 49	54°F (12°C)	100°F (37.5)	54°F (12°C)
Heating Lockout Temperature	AV 50	-15°F (-26°C)	120°F (49°C)	120°F (49°C)
Cooling Lockout Temperature	AV 51	-40°F (-40°C)	95°F (35°C)	-40°F (-40°C)
Deadband	AV 52	2°F (1°C)	4°F (2°C)	2°F (1°C)
Password Value	AV 59	0	1000	0
Power-up Delay	AV 60	10 sec	120 sec	10 sec
Unoccupied Time	AV 68	0.5 hrs	24.0. hrs	0.5 hrs
Economizer Changeover Setpoint	AV 77	14°F (-10°C)	70°F (21°C)	55°F (13°C)
Economizer Minimum Position	AV 78	0%	100%	0%
Mixed Air Setpoint	AV 80	50°F (10°C)	90°F (32°C)	55°F (13°C)
High Balance Point	AV 82	34°F (1°C)	90°F (32°C)	90°F (32°C)
Low Balance Point	AV 83	-40°F (-40°C)	30°F (-1°C)	-12°F (-24°C)
Dehumidification RH Setpoint	AV 89	15%	95%	70%
Dehumidification Hysterisys	AV 90	2%	20%	5%
Dehumidification Low OA Lockout	AV 91	-40°F (-40°C)	122°F (50°C)	32°F (0°C)
Humidification RH Setpoint	AV 95	10%	90%	50%
Eff (Effective) Reset Humidification RH Spt (Setpoint)	AV 96	0%	100%	N/A
Humidification High Limit Spt (Setpoint)	AV 97	50%	90%	85%
Low RH Setpoint	AV 98	10%	90%	20%
Low Temp Reset RH Setpoint	AV 99	-40°F (-40°C)	15°F (-9.5°C)	-20°F (-29°C)
High Temp Reset RH Setpoint	AV 100	20°F (-6.5°C)	55°F (13°C)	32°F (0.0°C)
Humidifier Output	AV 101	0%	100%	N/A

## List of Property Enumeration Sets for BI and BV objects

Table 9. List of Property Enumeration Sets for BI and BV objects

Object Name	Object Type and instance	Inactive_Text	Active_Text	Default value
Room Temp Override	BV 8	Normal	Override	Normal
Outdoor Temp Override	BV 10	Normal	Override	Normal
AUX	BI 24	Off	On	Off
G Fan	BI 25	Off	On	Off
Y1 Cool	BI 26	Off	On	Off
Y2 Cool	BI 27	Off	On	Off
W1 Heat	BI 28	Off	On	Off
W2 Heat	BI 29	Off	On	Off
Reversing Valve	BI 30	Off	On	Off
DI 1 Status	BI 31	Not Activated	Activated	Not Activated
DI 2 Status	BI 32	Not Activated	Activated	Not Activated
Local Motion	BI 33	No Motion	Motion	No Motion
Frost Alarm	BI 36	Off	On	Off
Clock Alarm	BI 37	Off	On	Off
Filter Alarm	BI 38	Off	On	Off
Service Alarm	BI 39	Off	On	Off
Fan Lock Alarm	BI 40	Off	On	Off
Temperature Scale	BV 47	°C	°F	°F
Frost Protection	BV 55	Off	On	Off
Aux Contact	BV 56	N.O.	N.C.	N.O.
Menu Scroll	BV 57	No Scroll	Scroll Active	Scroll Active
Fan Control	BV 62	Off	On	On
Fan Purge Delay	BV 64	Off	On	Off
Progressive Recovery	BV 70	Off	Active	Off
Mechanical Cooling Enabled	BV 79	Off	On	Off
Comfort Mode	BV 84	Comfort	Economy	Comfort
Reversing Valve Configuration	BV 85	Energized in Heating	Energized in Cooling	Energized in Cooling
Compressor Interlock	BV 86	Off	On	Off
RH Display	BV 88	Disabled	Enabled	Disabled
Dehumidification Lockout Functions	BV 92	Disabled	Enabled	Enabled
Dehumidification Output Status	BI 93	Off	On	N/A

## Property Enumeration Sets for MV Objects

Table 10. Property Enumeration Sets for MV Objects

Object Name	Object Type and instance	BACnet Index	Text	Default value
Occupancy Command	MV12	1	Local Occupancy	Local Occupancy
		2	Occupied	
		3	Unoccupied	
System Mode HPU	MV13	1	Off	Auto
		2	Auto	
		3	Cool	
		4	Heat	
		5	Emergency	
System Mode RTU	MV14	1	Off	Auto
		2	Auto	
		3	Cool	
		4	Heat	
Fan Mode	MV15	1	On	Smart
		2	Auto	
		3	Smart	
Keypad Lockout	MV18	1	Level 0	Level 0
		2	Level 1	
		3	Level 2	
Effective Occupancy	MV 34	1	Occupied	Depends on local occupancy
		2	Unoccupied	
		3	Temporary Occupied	
Heating CPH	MV53	1	3 CPH	4 CPH
		2	4 CPH	
		3	5 CPH	
		4	6 CPH	
		5	7 CPH	
		6	8 CPH	
Cooling CPH	MV54	1	3 CPH	4 CPH
		2	4 CPH	

Table 10. Property Enumeration Sets for MV Objects

Object Name	Object Type and instance	BACnet Index	Text	Default value
Temporary Occupancy Time	MV61	1	0 hour	3 hours
		2	1 hour	
		3	2 hours	
		4	3 hours	
		5	4 hours	
		6	5 hours	
		7	6 hours	
		8	7 hours	
		9	8 hours	
		10	9 hours	
		11	10 hours	
		12	11 hours	
		13	12 hours	
Anticycle	MV63	1	0 minute	2 minutes
		2	1 minute	
		3	2 minutes	
		4	3 minutes	
		5	4 minutes	
		6	5 minutes	
DI1 Configuration	MV65	1	None	None
		2	RemNSB	
		3	RemOVR	
		4	Filter	
		5	Service	
		6	Fan lock	
DI2 Configuration	MV66	1	None	None
		2	RemNSB	
		3	RemOVR	
		4	Filter	
		5	Service	
		6	Fan lock	
Proportional Band	MV 67	1	2 2 F 0.6 C	2
		2	3 3 F 1.2 C	
		3	4 4 F 1.7 C	
		4	5 5 F 2.2 C	
		5	6 6 F 2.8 C	
		6	7 7 F 3.3 C	
		7	8 8 F 3.9 C	
Event Display	MV71	1	2 Events	2 Event
		2	4 Events	

**Table 10. Property Enumeration Sets for MV Objects**

<b>Object Name</b>	<b>Object Type and instance</b>	<b>BACnet Index</b>	<b>Text</b>	<b>Default value</b>
Heating Stages	MV73	1	1 Stage	2 Stages
		2	2 Stages	
Cooling Stages	MV74	1	1 Stage	2 Stages
		2	2 Stages	
Heat Pump Stages	MV75	1	1 Stage	2 Stages
		2	2 Stages	



**Automation and Control Solutions**

Honeywell International Inc.  
1985 Douglas Drive North  
Golden Valley, MN 55422

Honeywell Limited-Honeywell Limitée  
35 Dynamic Drive  
Toronto, Ontario M1V 4Z9  
[customer.honeywell.com](http://customer.honeywell.com)

® U.S. Registered Trademark  
© 2011 Honeywell International Inc.  
63-4523—01 M.S. 04-11  
Printed in U.S.A.

**Honeywell**