

Gravity Gun

AirVerter[®]

HVLP PAINT SPRAY SYSTEM



User s Manual

**Gravity Gun
GG**

Smith Eastern Corporation

10630-S Riggs Hill Road • Jessup, Maryland 20794-9425 USA
301.497.7600 • 800.937.HVLP (4857) • Fax 301.497.7613
gravity@airverter.com • www.airverter.com

Compliance • Quality • Performance • Reliability

AirVerter[®] Gravity Gun HVLP Paint Spray System

DO NOT OPERATE SPRAY GUNS WITHOUT PERSONAL SAFETY EQUIPMENT

**Please Read This Owner's Manual *BEFORE*
Using Your Gravity Gun**

DO NOT OPERATE THIS EQUIPMENT WITHOUT USING PROPER PERSONAL SAFETY EQUIPMENT INCLUDING RESPIRATOR, GOGGLES AND SAFETY CLOTHING. OBSERVE ALL PRECAUTIONS RELATED TO SPRAYING.

WARNING

THIS EQUIPMENT IS OPERATED USING PRESSURIZED AIR. ALWAYS DISCONNECT SPRAY GUN FROM AIR AND FLUID HOSES AND DEPRESSURIZE SYSTEM PRIOR TO ANY MAINTENANCE OR DISASSEMBLY PROCEDURE.

WARRANTY

Smith Eastern Corporation warrants to the Purchaser that the GG-100 Gravity Gun is free from defects in material or workmanship under normal use and service for a period of twelve (12) months from the date of purchase. Should any failure appear during this period, Smith Eastern shall, if given prompt written notice by the Purchaser, correct such nonconformity by repair or replacement of the nonconforming part, F.O.B. Smith Eastern's repair facility. Repair parts are warranted for ninety (90) days from the date of shipment, but repairs or replacements to original equipment shall not renew or extend the warranty period of such equipment. Equipment and parts furnished by Smith Eastern but manufactured by others shall be limited to the warranty offered by the manufacturer thereof.

Smith Eastern reserves the right to limit this warranty in cases of misuse or abuse. Any modifications to spray guns or recommended procedures will void the warranty.

The foregoing warranty is exclusive and in lieu of other warranties of quality or performance, expressed, implied or statutory, including any warranties of merchantability or of fitness for a particular purpose.

Why Airverter[®] Spray Gun Systems Work Better

To accomplish effective atomization of a liquid at low pressure (below 10 PSI) it is necessary to substantially decrease pressure (PSI) and increase air volume (CFM). AirVerter[®] systems, by design, do not exceed 10 PSI at the spray head and prevent the operator from taking AirVerter[®] spray guns out of compliance with EPA and California's South Coast Air Quality Management District (SCAQMD) regulations.

AirVerter[®] Gravity Gun HVLP Paint Spray System

EQUIPMENT REQUIREMENTS

Air Compressor

Air compressors used with AirVerter[®] Spray Guns must be able to HOLD a minimum of 40 PSI while spraying. **Note:** Position a pressure gauge in the air hose nearest the spray gun to be assured of the PSI required to satisfactorily spray your coating.

High Pressure Air Hose

- A. Air hose lengths up to 50 feet **MUST** have an I.D. of 3/8" including fittings.
- B. Air hose lengths greater than 50 feet **MUST** have an I.D. of 1/2" including fittings.

OPERATING INSTRUCTIONS

OPERATION:

Starting:

- A. The Gravity Gun GG-100 Spray Gun operates with the trigger controlling both the fluid flow and air flow.
- B. **Consult the Needle, Nozzle and Air Cap Selection Guide to select the proper combination for the coating and finish quality desired. Too much pressure will create unnecessary overspray!**

Before Spraying

- A. Follow the *Air and Paint Management Guidelines* listed on the following page.
- B. Before paint is poured into the cup, **make certain paint is properly mixed.** This is particularly true when mixing multi-component paints. Use a paint shaker, rotary mixer, or paint paddle to achieve a homogeneous mixture. (*Hint: Split your paint into two parts; the top will be lighter and the bottom will be heavier. Completely stir the bottom half of the paint and slowly add small amounts of the top half into the heavier bottom.*)
- C. **Strain your paint to remove impurities.** Use a cone strainer or a 100-mesh nylon bag or equivalent strainer.
- D. **Thin your paint** according to the manufacturer's specifications.
- E. **Ensure needle packings are properly adjusted.** Needle packings are preset at the factory to proper tension. However, use and cleaning may alter this setting. To adjust needle packings to proper tension:
 1. With gun disconnected from air and fluid sources, pull trigger to move the needle out of the nozzle.

2. Adjust packing nut until needle is held in the open position by tension from the needle packings.
3. Loosen packing nut approximately ¼ turn or until needle returns to closed position.
4. Connect air supply hose to the Air Inlet Fitting (GG-027) at handle of gun.
5. The Air Control Valve (GG-026) in the gun handle can be used to adjust gun inlet pressure
6. Screw the Paint Cup (GG-031) onto the Fluid Inlet Fitting (GG-011)

Spraying

- A. Gravity forces paint from the paint container into the fluid chamber of the gun and out through the nozzle where the flow of atomizing air breaks the paint stream into tiny particles, creating the spray.
 1. Needle position controls the amount of paint flowing through the fluid nozzle.
 2. Trigger action controls needle position.
 3. The Fluid Control Knob (GG-015) at the rear of the spray gun controls trigger action. Turning the knob to the right reduces the fluid flow, turning it to the left increases the flow.
- B. Adjust the pattern by turning the Fan Control Assembly (GG-013) at the rear of the Spray Gun.
 1. Round Pattern - used to draw fine lines with the gun close to the work, for touch-up work, camouflage patterns and painting surfaces in difficult to reach places distant from the spray gun. This pattern is achieved by turning the Fan Control Knob clockwise
 2. Full Fan Pattern - used with the spray gun 6"-8" from the work. Overlap not more than

DO NOT OPERATE SPRAY GUNS WITHOUT PERSONAL SAFETY EQUIPMENT

AirVerter[®] Gravity Gun HVLP Paint Spray System

50% of the previous pass. Do not “fog” coat. This pattern is achieved by turning the Fan Control Knob counterclockwise.

3. The full fan pattern may be reduced in size by gradually turning the Fan Control Knob clockwise. **Fluid flow** must be **reduced** at

the same time to maintain even paint distribution.

- C. If you are having problems with the operation of your paint gun, check the Trouble Shooting Guide at the end of the manual for possible causes and solutions.

Air and Paint Management Guidelines

Approximate PSI	Application
Thin Coatings ZAHN #2 Test: 16 to 22 seconds Minimum 40 PSI compressor pressure	Machines and implements, small parts, plant maintenance, controlled production work, work in enclosed areas with poor ventilation, priming.
Thin to Medium Coatings ZAHN #2 Test: 22 to 30 seconds 40 to 60 PSI compressor pressure	Dual gun work for all of the above listed applications - will support up to 50' of 3/8" ID hose for each gun. Also for higher production levels of all of the above.
High Solid Coatings ZAHN #3 Test: 37 + seconds 50 to 70 PSI compressor pressure	Marine epoxies, marine enamels, high production steelwork, high production with conveyer lines, large surfaces with thinner viscosity material, latex on wood or metal.
80% Solids Coatings 60 to 80 PSI compressor pressure	Ultra high production levels on extremely large surfaces; un-thinned epoxies, enamels, latex, urethane.

WARNING

Gun must be de-pressurized prior to any maintenance or disassembly procedure. Disconnect all air hoses prior to performing any maintenance operation.

Cleaning the Gravity Gun

Cleaning and Gun Care

- A. Remove the Air Cap and Ring and clean with solvent.
- B. Flush gun thoroughly with solvent.
- C. Clean nozzle with brush. Never place the whole gun in solvent.

- D. Clogged holes should never be cleaned with hard objects as the smallest amount of damage may badly influence the spray pattern.
- E. Packing must be slightly lubricated after cleaning of gun.

Spray Gun Performance Is Directly Related To How Well The Gun Is Cleaned After Use

DO NOT OPERATE SPRAY GUNS WITHOUT PERSONAL SAFETY EQUIPMENT

AirVerter[®] Gravity Gun HVLP Paint Spray System

Lubricate

- A. Use Vaseline or a non-silicone grease to lubricate the gun.
- B. Lubricate all threaded connections for ease of maintenance.
- C. Lubricate the Needle only where it passes through the needle packings.
- D. **DO NOT** allow lubricant to get into the Fluid Tube, Nozzle, Air Cap, or interior of the paint chamber (areas where paint may come in contact with lubricant).

Gun Head Disassembly and Re-assembly Instructions

(Note: Gun Head disassembly is not recommended for normal cleaning and maintenance.)

Gun Head Disassembly

To remove the nozzle carrier and air cap adapter:

- A. Remove the Air Cap (GG-001), Fluid Nozzle Body (GG-002) and Fluid Needle (GG-014).
- B. Remove the Needle Seal Cartridge (GG-024).
- C. Loosen the Lock Nut (GG-010) on the Fluid Inlet Fitting (GG-011).
- D. Unscrew the Fluid Inlet Fitting from the gun
- E. The Nozzle Carrier (GG-005) and Air Cap Adapter (GG-006) will now slide forward from the Gun Handle (GG-012). *Note: a seal will remain in the gun body and should not be removed. The Copper Gasket and Lower Seal should be replaced.*

Gun Head Re-assembly

- A. Thread the Lock Nut back against the hex on the Fluid Inlet Fitting. Slide seal onto the Fluid Inlet Fitting. Thread the copper gasket onto the Fluid Inlet Fitting.
- B. Install O-ring onto the Air Cap Adapter.
- C. Slide the Nozzle Carrier into the Air Cap Adapter and rotate until the inlet port in the Nozzle Carrier is aligned with the hole in the Air Cap Adapter; the two will lock together in this position.
- D. Holding the Nozzle Carrier and Air Cap Adapter together in the position described, slide them into the gun head and rotate until the locating pin is aligned with the slot in the Gun Body and slide further into the Gun Body.
- E. Install the Needle Seal Cartridge and tighten to approx. 150-175 in-lb. torque.
- F. Install the Fluid Inlet Fitting and tighten to approx. 175 in-lb. torque. Tighten the Lock Nut against the Gun Body.

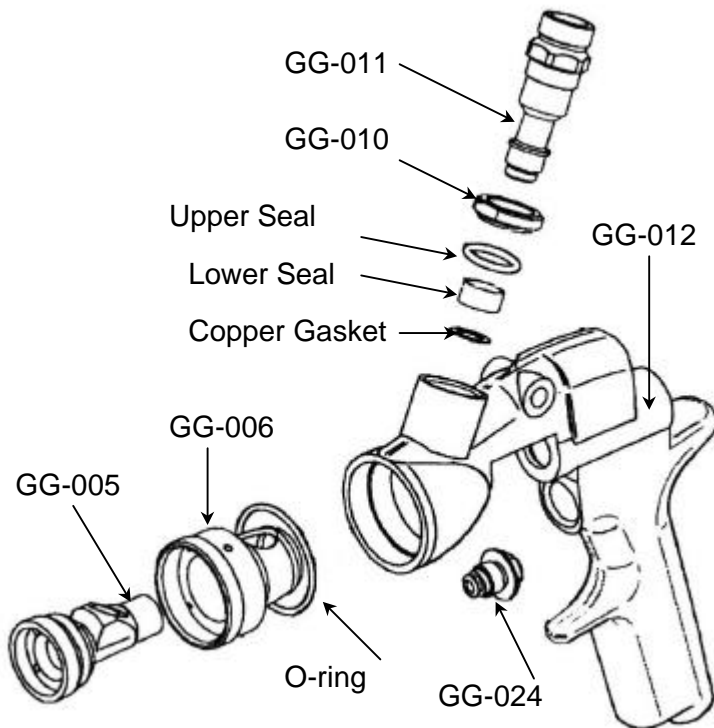

DO NOT OPERATE SPRAY GUNS WITHOUT PERSONAL SAFETY EQUIPMENT

AirVerter® Gravity Gun HVLP Paint Spray System

Gravity Gun Illustrated Parts Breakdown

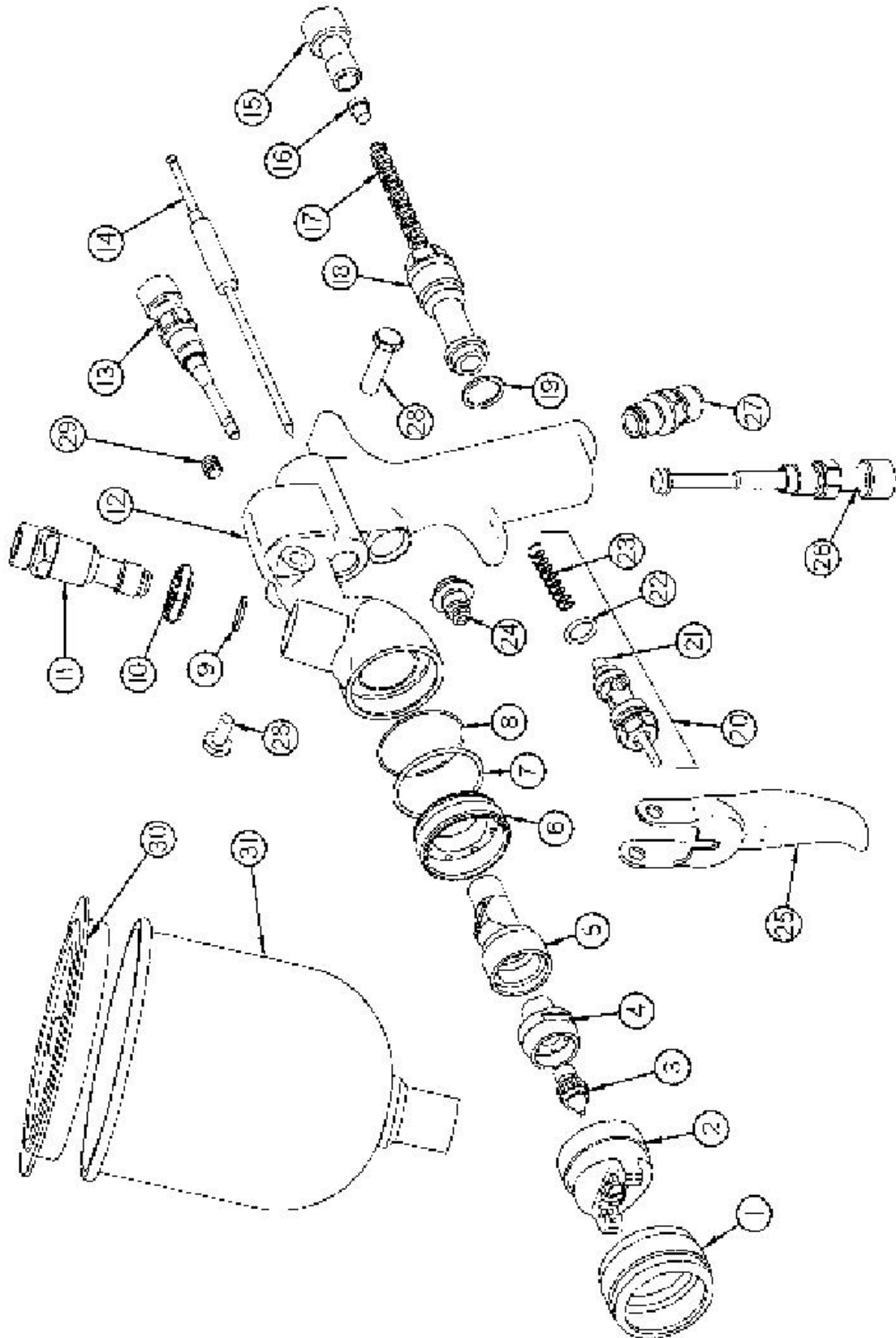

DO NOT OPERATE SPRAY GUNS WITHOUT PERSONAL SAFETY EQUIPMENT

AirVerter® Gravity Gun HVLP Paint Spray System

Gravity Gun Parts List

	Part #	NSN	Description
1 & 2	GG-001-xx	4940-01-481-0571	Air Cap with Ring
3	GG-003-xx		Fluid Nozzle Tip
4	GG-002		Fluid Nozzle Body
5	GG-005		Nozzle Carrier
6	GG-006		Air Cap Adapter
7	Note 1		O-Ring
8	Note 1		O-Ring
9	Note 1		Seal
10	GG-010		Lock Nut
11	GG-011		Fluid Inlet Fitting
12	GG-012		Gun Body HVLP
13	GG-013		Fan Control Assembly
14	GG-014-xx		Fluid Needle
15	GG-015		Fluid Control Knob
16	Note 1		Spring Seat
17	Note 1		Needle Return Spring
18	GG-018		Rear Bushing
19	Note 1		Seal
20	GG-020		Air Valve Assembly
21	GG-021		Air Valve Poppet
22	Note 1		O-Ring
23	Note 1		Air Valve Spring
24	GG-024		Needle Seal Cartridge
25	GG-025		Trigger
26	GG-026		Air Control
27	GG-027		Air Inlet Fitting
28	GG-028		Trigger Pivot Set
29			Allen Plug
30	GG-030		Cup Lid (3 pack for Stainless Steel cup)
31	GG-029		Gravity Feed Cup, Aluminum (750 cc) Std.

Note 1: These parts are contained in the High Wear Kit, Part # GG-125

DO NOT OPERATE SPRAY GUNS WITHOUT PERSONAL SAFETY EQUIPMENT

AirVerter[®] Gravity Gun HVLP Paint Spray System

Needle, Nozzle and Air Cap Selection Guide

Select the proper fluid nozzle and needle for the material to be sprayed. Needle and nozzle are a matched set - machined to act as a valve. Replace the Needle and Nozzle when the Needle protrudes approximately 3/32" beyond the Nozzle.

Finish	Needle Nozzle	Air Cap	Uses or Coating Type	Compressor Air Pressure*
Ultra Fine Finish	0.7	5	Ultra Fine Finish With Thin Coatings on Small Parts Ultra Fine Touch Up Specialty Applications/Wood Working Water-Based Lacquers, Urethanes	45- 50
Excellent Finish Good Production	1.0	5	Automotive Base or Clear Coat Top Coats For Automotive, Aviation and Marine Use Wood: Lacquers, Stains, Polyurethanes, Varnishes Thin Specialty Coatings With Low Mil Build and Fine Finish Requirements Water-Based Coatings	45-55
Good Finish High Production	1.2	10	Higher Production For The Same Applications As Above Fine Finish With Gloss Alkyd Enamel Primers and Sealers For Automotive, Aviation and Marine Water-Based Coatings	55-65
Excellent Finish Good Production	1.4	12	General Industrial Finishing Zinc-Rich Primers, Water-Based Primers, Flat & Semi-Gloss Alkyd Enamels & Polyurethanes Industrial, Marine, Top Coats, Chlorinated Alkyd Enamels, Acrylic Enamels, and Latex Best with Heavy Primers CARC	65-75
Best Finish High Production	1.7	17	High Production Industrial Marine Primers, High Build Primers, Steel Structures Latex	75-85
Good Finish Higher Production	2.0	20	CARC Industrial Finish Coatings Latex, Stripper, Oil	85-90

*Measured at the gun handle.

Nozzle Size Expressed in Millimeters • 1 Millimeter = .040 (Approximately)					
0.7 = .028	1.0 = .040	1.2 = .048	1.4 = .056	1.7 = .067	2.0 = .080

DO NOT OPERATE SPRAY GUNS WITHOUT PERSONAL SAFETY EQUIPMENT

AirVerter® Gravity Gun HVLP Paint Spray System

Gravity Gun Troubleshooting Guide

Trouble	Probable Cause	Remedy
Paint Will Not Flow	<ol style="list-style-type: none">1. Blockage in fluid nozzle2. Loose fluid nozzle3. Coating is too thick4. Loose needle packing	<ol style="list-style-type: none">1. Clean or replace; strain paint2. Tighten3. Thin the coating4. Adjust packing
Inconsistent Spray Pattern (Spits and Sputters)	<ol style="list-style-type: none">1. Running out of paint2. Loose needle packing	<ol style="list-style-type: none">1. Fill cup or pot, but never the top ¼2. Adjust packing
Leakage at Front of Gun	<ol style="list-style-type: none">1. Damaged fluid needle2. Wrong size fluid needle3. Dirty fluid nozzle4. Impurities in paint5. Loose fluid nozzle6. Fluid adjustment screwed all the way out7. Needle not firmly seated in the nozzle8. Packing too tight	<ol style="list-style-type: none">1. Replace2. Replace3. Clean4. Strain paint5. Tighten6. Rotate Fluid Control Knob (GG-015) on rear of gun clockwise7. Check for nozzle obstruction8. Loosen and adjust to correct tension
Distorted Spray Pattern	<ol style="list-style-type: none">1. Dirty or damaged air cap2. Dirty or damaged fluid nozzle or needle3. Fluid nozzle partially clogged4. Fluid nozzle not centered with air cap5. Air cap not seated correctly	<ol style="list-style-type: none">1. Clean or replace2. Clean or replace3. Clean4. Replace air cap5. Re-seat air cap

DO NOT OPERATE SPRAY GUNS WITHOUT PERSONAL SAFETY EQUIPMENT

AirVerter[®] Gravity Gun HVLP Paint Spray System

**GG-125 High-Wear Maintenance Kit
For GG-100 Gravity Gun**

Part #	NSN #	Description	Qty
		O-Ring	1
		O-Ring	1
		Seal	1
		Spring Seat	1
		Needle Return Spring	1
		Seal	1
		O-Ring	1
		Air Valve Spring	1
GG-024		Needle Seal Cartridge	1

DO NOT OPERATE SPRAY GUNS WITHOUT PERSONAL SAFETY EQUIPMENT



AirVerte®