

A17 - 6U MPC8548 VMEbus 2eSST CPU Board

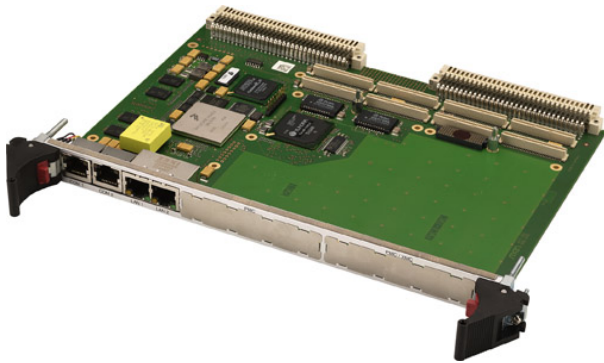

- PowerPC® MPC8548 (or MPC8543), up to 1.5 GHz
- 1-slot 2eSST VMEbus master and slave
- Up to 2 GB (ECC) DDR2 RAM
- Flash Disk, FRAM
- 2 Gb Ethernet, 2 COMs at front
- 2 Gb Ethernet via P0
- 2 PMC slots (1 slot also XMC)
- FPGA for individual I/O functions
- MENMON™ BIOS for PowerPC® cards
- -40 to +85°C screened

The A17 is an advanced PowerPC® based single-board computer for embedded applications and can act as a master or a slave in a legacy VMEbus environment. Using the TS1148 bridge controller the CPU card provides 2eSST performance levels while maintaining backwards compatibility with older standards such as VME64 and VME32. The 2eSST protocol is based on synchronous data transfer and thus doubles the theoretical VME transaction bandwidth to transfer rates of up to 320 MB/s.

The A17 is controlled by an MPC8548, or optionally an MPC8543 PowerPC® processor (alternatively with encryption unit) with clock frequencies between 800 MHz and 1.5 GHz. The SBC is equipped with ECC-controlled DDR2 RAM for data storage, with a Flash disk for program storage as well as with non-volatile FRAM. The board provides front-panel access for two Gigabit Ethernet and two COM interfaces via four RJ45 connectors. Another two Gigabit Ethernet channels are available at the optional P0 rear connector to support Ethernet on the backplane complying with

ANSI/VITA 31.1-2003.

The two PMC slots on the A17 support PMC modules working with 32-bit/33-MHz up to 64-bit/66-MHz. One of the mezzanine slots supports rear I/O and can also be used for XMC modules with a PCI Express® x1, x2, or x4 link. The second (PMC only) slot is connected to the onboard FPGA and can thus act as the physical layer for additional functions implemented in the FPGA. The PMC/XMC slots allow flexible extension to the A17, adding functions such as graphics, mass storage, further Ethernet, or a simple FPGA-backed physical layer. Even more I/O functions such as graphics, touch, CAN, binary I/O etc. can be realized as IP cores in FPGA for the needs of the individual application. The A17 comes with MENMON™ support. This firmware/BIOS can be used for bootstrapping operating systems (from disk, Flash or network), for hardware testing, or for debugging applications without running any operating system.

Technical Data

CPU

- PowerPC® PowerQUICC™ III MPC8548, MPC8548E, MPC8543 or MPC8543E
 - 800 MHz up to 1.5 GHz
 - Please see Standard Configurations for available standard versions.
 - e500 PowerPC® core with MMU and double-precision embedded scalar and vector floating-point APU
 - Integrated Northbridge and Southbridge

Memory

- 2x32 KB L1 data and instruction cache, 512 KB/256 KB L2 cache integrated in MPC8548/MPC8543
- Up to 2 GB SDRAM system memory
 - Soldered
 - DDR2 with or without ECC
 - Up to 300 MHz memory bus frequency, depending on CPU
- Up to 4 GB soldered Flash disk (SSD solid state disk)
 - Higher capacity possible if components are available
 - FPGA-controlled
- 16 MB boot Flash
- 128 KB non-volatile FRAM
- Serial EEPROM 8 kbits for factory settings

Mass Storage

- Up to 4 GB soldered ATA Flash disk (SSD solid state disk)
 - Higher capacity possible when components are available
 - FPGA-controlled

I/O

- Ethernet
 - Up to four 10/100/1000Base-T Ethernet channels
 - Two RJ45 connectors at front panel
 - Two front LEDs per channel to signal LAN Link and Activity
 - Two channels accessible via rear I/O on connector P0 complying with ANSI/VITA 31.1-2003 (option)
- Two RS232 UARTs (COM1/2)
 - Two RJ45 connectors at front panel
 - Data rates up to 115.2 kbit/s
 - 16-byte transmit/receive buffer
 - Handshake lines: CTS, RTS
- GPIO
 - 31 GPIO lines
 - FPGA-controlled
 - Connection via PMC1 board-to-board connector J4

Front Connections

- Two Ethernet (RJ45)
- COM1/COM2 (RJ45)
- XMC/PMC 0 and PMC 1

Rear I/O

- Two 10/100/1000Base-T Ethernet on P0 (option)
- Mezzanine rear I/O: PMC 0 on P2

Mezzanine Slots

- Two slots total, one slot usable for PMC or XMC
- One XMC slot
 - Compliant with XMC standard VITA 42.3-2006
 - PCI Express® links: one x1 or one x2 or one x4
- Two PMC slots
 - Compliant with PMC standard IEEE 1386.1
 - Up to 64-bit/64-MHz, 3.3 V V(I/O)
 - PMC I/O module (PIM) support through J4 complying with VITA 35 (PMC 0)

Miscellaneous

- Real-time clock with battery backup
- Temperature sensor, power supervision and watchdog
- Reset button in ejector handle
- One power good LED, three user-configurable LEDs at front

Local PCI Bus

- 64-bit/66-MHz, 3.3 V V(I/O)
- Compliant with PCI Specification 2.2

VMEbus

- TS1148 controller
- Compliant with VME64 Specification
- Supports VME32, VME64, 2eVME and 2eSST (VITA 1.5)
 - Optional single 5V supply for operation in VME32 systems
- Slot-1 function with auto-detection
- Master
 - D08:D16:D32:D64:A16:A24:A32:A64:BLT:MBLT:RMW
- Slave
 - D08:D16:D32:D64:A16:A24:A32:A64:BLT:MBLT
- DMA
- Mailbox functionality
- Bus timer
- Location Monitor
- Interrupter D08(O):I(7-1):ROAK
- Interrupt handler D08(O):IH(7-1)
- Single level 3 fair requester
- Single level 3 arbiter

Electrical Specifications

- Supply voltage/power consumption:
 - +5 V (-3%/+5%), approx. 2.2 A
 - +3.3 V (-3%/+5%), approx. 1.1 A
 - +12 V (-5%/+5%), only provided for PMCs that need 12 V
 - -12 V (-5%/+5%), only provided for PMCs that need 12 V

Technical Data

Mechanical Specifications

- Dimensions: standard double Eurocard, 233.3 mm x 160 mm
- Weight: 490 g (incl. heat sink, without XMC/PMC modules)

Environmental Specifications

- Temperature range (operation):
 - -40..+85°C (screened)
 - Airflow: min. 10 m³/h
- Temperature range (storage): -40..+85°C
- Relative humidity (operation): max. 95% non-condensing
- Relative humidity (storage): max. 95% non-condensing
- Altitude: -300 m to +3,000 m
- Shock: 15 g, 11 ms
- Bump: 10 g, 16 ms
- Vibration (sinusoidal): 1 g, 10..150 Hz
- Conformal coating on request

MTBF

- 220,017 h @ 40°C according to IEC/TR 62380 (RDF 2000)

Safety

- PCB manufactured with a flammability rating of 94V-0 by UL recognized manufacturers

EMC

- Conforming to EN 55022 (radio disturbance), IEC1000-4-2 (ESD) and IEC1000-4-4 (burst)

BIOS

- MENMON™

Software Support

- Linux
- VxWorks®
- QNX® (on request; support of the FPU is currently not provided by QNX®)
- OS-9® (on request)
- [For more information on supported operating system versions and drivers see Software.](#)

Diagram

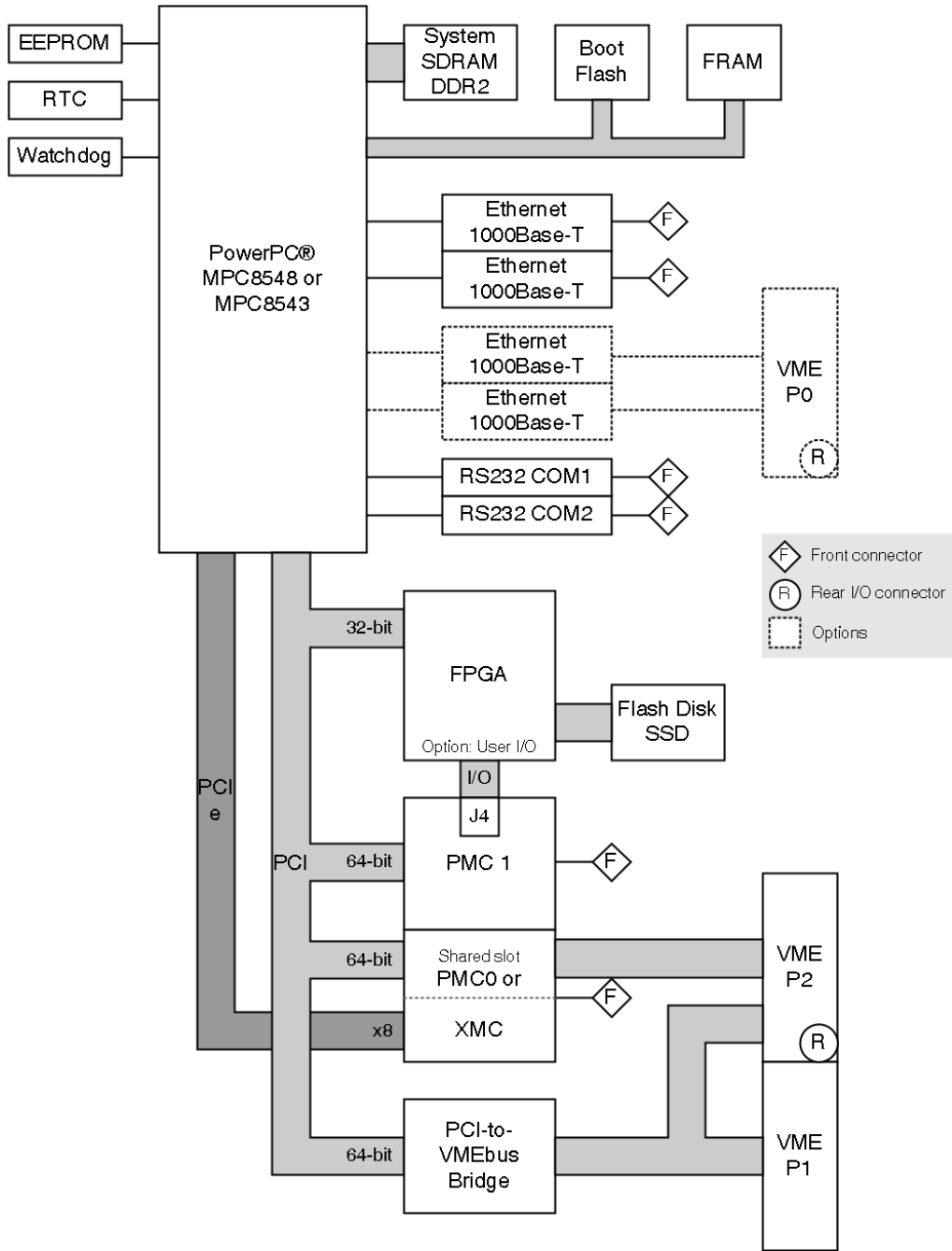

Configuration & Options

Standard Configurations

Article No.	CPU Type	Clock	System RAM	Flash Disk	FRAM	P0 Ethernet	Operation Temperature
01A017-00	MPC8548	1.33 GHz	1 GB ECC	2 GB	128 KB	No	-40..+85°C

Options

CPU

- Several PowerQUICC™ III types with different clock frequencies
- MPC8548 or MPC8548E
 - 1 GHz, 1.2 GHz, 1.33 GHz or 1.5 GHz
- MPC8543 or MPC8543E
 - 800 MHz or 1 GHz

Please note that some of these options may only be available for large volumes. Please ask our sales staff for more information.

Memory

- System RAM
 - 512 MB, 1 GB or 2 GB
 - With or without ECC
- Flash Disk
 - 0 GB up to 4 GB (and more, if components are available)
- FRAM
 - 0 KB or 128 KB

I/O

- Ethernet
 - Two additional Gigabit Ethernet channels on VMEbus P0 rear connector for ANSI/VITA 31.1-2003 support (only with MPC8548)
 - Only two channels (at front) instead of four with MPC8543
- PCI Express® links: one x8 link
 - Reduces operation temperature range because of higher DDR SDRAM clock

FPGA

- The onboard FPGA offers the possibility to add customized I/O functionality.
- FPGA Altera® Cyclone® II EP2C35
 - 33,216 logic elements
 - 483,840 total RAM bits
- Connection
 - Total available pin count: 31 pins
 - Functions available via PMC slot 1 connector Pn4
- [You can find more information on our web page "User I/O in FPGA"](#)

VMEbus

- Single 5V supply for operation in VME32 systems

Ordering Information

Standard A17 Models

01A017-00 MPC8548 / 1.33 GHz, 1 GB DDR2 DRAM, 2 GB Flash disk, 128 KB FRAM, P0 not mounted, -40..+85°C screened

Systems & Card Cages

MEN delivers turn-key systems completely installed (hardware, operating system, accessories), wired and tested. Different rack sizes, power supplies and backplanes on request. For details please contact your local sales representative.

Miscellaneous Accessories

05F006-00 RS232 interface cable RJ45 to 9-pin D-Sub (1 COM to 1 COM), 2m

05P000-01 25 mounting screw sets to fix PMC/XMC modules on carrier boards

Software: Linux

This product is designed to work under Linux. See below for potentially available separate software packages from MEN.

10EM09-91 General Linux BSP for A17, EM9, EM9A, EK9, F50C, F50P and XM50

13Z014-90 Linux device driver (MEN) for PCI-to-VME bridge on A12, A13, A14, A15, A17, A19, A20 and B11

13Z017-06 MDIS5™ low-level driver sources (MEN) for 16Z034_GPIO and 16Z037_GPIO

Software: VxWorks

This product is designed to work under VxWorks®. For details regarding supported/unsupported board functions please refer to the corresponding software data sheets.

10EM09-60 VxWorks® BSP (MEN) for A17, EK9, EM9, EM9A, F50C, F50P and XM50

13Z017-06 MDIS5™ low-level driver sources (MEN) for 16Z034_GPIO and 16Z037_GPIO

Software: Firmware/BIOS

MENMON™ is MEN's firmware/BIOS for PowerPC® platforms.

14A017-00 MENMON™ (Firmware) (MEN) for A17 (object code)

For operating systems not mentioned here contact MEN sales.

Documentation

Compare Chart 6U VMEbus CPU and I/O cards Download

20A017-ER A17 Errata

20A017-00 A17 User Manual

For the most up-to-date ordering information and direct links to other data sheets and downloads, see the A17 online data sheet under » www.men.de.

Contact Information

Germany

MEN Mikro Elektronik GmbH
 Neuwieder Straße 3-7
 90411 Nuremberg
 Phone +49-911-99 33 5-0
 Fax +49-911-99 33 5-901
 E-mail info@men.de
www.men.de

France

MEN Mikro Elektronik SA
 18, rue René Cassin
 ZA de la Châtelaïne
 74240 Gaillard
 Phone +33 (0) 450-955-312
 Fax +33 (0) 450-955-211
 E-mail info@men-france.fr
www.men-france.fr

USA

MEN Micro, Inc.
 24 North Main Street
 Ambler, PA 19002
 Phone (215) 542-9575
 Fax (215) 542-9577
 E-mail sales@menmicro.com
www.menmicro.com

The date of issue stated in this data sheet refers to the Technical Data only. Changes in ordering information given herein do not affect the date of issue.

All brand or product names are trademarks or registered trademarks of their respective holders.

MEN is not responsible for the results of any actions taken on the basis of information in the publication, nor for any error in or omission from the publication.

MEN expressly disclaims all and any liability and responsibility to any person, whether a reader of the publication or not, in respect of anything, and of the consequences of anything, done or omitted to be done by any such person in reliance, whether wholly or partially, on the whole or any part of the contents of the publication.

The correct function of MEN products in mission-critical and life-critical applications is limited to the environmental specification given for each product in the technical user manual. The correct function of MEN products under extended environmental conditions is limited to the individual requirement specification and subsequent validation documents for each product for the applicable use case and has to be agreed upon in writing by MEN and the customer. Should the customer purchase or use MEN products for any unintended or unauthorized application, the customer shall indemnify and hold MEN and its officers, employees, subsidiaries, affiliates, and distributors harmless against all claims, costs, damages, and expenses, and reasonable attorney fees arising out of, directly or indirectly, any claim or personal injury or death associated with such unintended or unauthorized use, even if such claim alleges that MEN was negligent regarding the design or manufacture of the part.

In no case is MEN liable for the correct function of the technical installation where MEN products are a part of.

Copyright © 2012 MEN Mikro Elektronik GmbH. All rights reserved.

