

CartManager XD+

Owner/Operator Training and Troubleshooting Guide



Version 1.0
August, 2007



Corporate Offices
Gatekeeper Systems
8 Studebaker
Irvine, CA 92675

Phone: (888) 808-9433

Internet: www.gatekeepersystems.com

For Gatekeeper Systems Regional Customer Support numbers, see page 48.

Copyright

Companies, names, and data used in examples herein are fictitious unless otherwise noted. No part of this document may be reproduced or transmitted in any form or by any means, electronic or mechanical, for any purpose, without the express written permission of Gatekeeper Systems. This document and the products it describes are furnished under a license agreement, and may be used or copied only in accordance with the terms of the license agreement.

© August 2007. Gatekeeper Systems. All rights reserved.

Information in this document is subject to change without notice. Gatekeeper Systems assumes no responsibility or liability for any errors, omissions, or inaccuracies that may appear in this document.

Trademarks

Gatekeeper Systems is a registered trademark of Gatekeeper Systems. All other brands and products are trademarks of their respective holder(s).

Table of Contents

Overview	1
Safety Precautions	2
CartManager XD+ Views	3
CartManager XD+ Features and Controls	6
Operator Training	7
Getting Started	7
PreOperations Checklist	8
Using CartManager XD+ – Manual Mode	9
Using CartManager XD+ – Remote Operations Mode	10
Retrieving Carts	11
Safety Guidelines and Operating Tips	13
Care of the CartManager XD+	15
Charging the CartManager Batteries	15
CartManager XD+ Maintenance	15
Post Training Quiz	17
Quiz Answers	19
Troubleshooting	21
Remote Control Issues	22
Changing the Remote Control Batteries	22
Remote Control Does Not Work	23
Electrical Issues	24
CartManager XD+ Does Not Turn On	24
CartManager XD+ Does Not Move	25
Battery Issues	26
Battery Chargers	27
Battery Runs Down Quickly	28
Replacing CartManager XD+ Batteries	28
Battery Indicator	29
Error Codes	30
Mechanical Procedures	33
Reference	36
Technical Specifications	36
Wiring Diagrams	38
Safety and Warning Labels	39
Ordering Parts	44
Warranty Information	46
Contacting Gatekeeper Systems	48

Overview

A line of thirty shopping carts can easily weigh 1000 pounds or more. When collecting carts from a large parking lot, that's a lot of weight to safely get moving, keep moving, steer and stop.

The Gatekeeper Systems CartManager XD+ is a battery powered drive unit that easily pushes a line of up to 30 carts. The operator controls the speed and direction of the CartManager XD+ using either a set of throttle grips (much like motorcycle handlebar grips) mounted on the back of the unit, or via a handheld remote control unit.

The operator can start the cart line moving with the push of a button, steer the cart line with one hand, and most importantly, stop the cart line immediately, if necessary.

This guide consists of three main sections; Operator Training, Troubleshooting and Common Mechanical Procedures.

Operator Training presents all the information required to safely operate CartManager XD+ for cart retrieval. This guide can be given to an operator for self-study or used by a trainer as the basis for a group training plan. Topics included are:

- Introduction to CartManager XD+
- How to do a pre-operations check
- Driving CartManager XD+ in both Manual and Remote Control Mode
- Safe cart retrieval techniques
- Basic care and maintenance of the CartManager XD+ and remote control unit

At the end of the training section is a quiz that should be given to each prospective CartManager XD+ operator to evaluate their readiness to safely use CartManager XD+.

The **Troubleshooting** section contains detailed instructions for on-site resolution of minor problems that may occur with CartManager XD+, as well as suggestions to help keep your CartManager XD+ running smoothly.

Mechanical Procedures details some of the more common maintenance procedures.

Reference contains technical specifications, wiring diagrams, safety and warning labels, and information on ordering replacement parts for CartManager XD+ and the remote control unit.

If at any time you need further assistance with training, troubleshooting or maintenance of CartManager XD+, please refer to the last page in this guide for information on contacting your nearest Gatekeeper Systems regional Customer Support center.

Safety Precautions

1. Do not operate, maintain or service CartManager XD+:
 - Unless trained and authorized,
 - Unless operation manual is read and understood,
 - In areas where flammable or explosive gases may be present.
2. Before operating CartManager XD+, make sure all safety devices are in place and operating properly.
3. When maintaining or servicing CartManager XD+:
 - Disconnect battery connection before working on the machine.
 - Do not open the sealed, maintenance free batteries.
 - Avoid moving parts. Do not wear loose jackets, shirts, ties or sleeves when working on CartManager XD+.
 - Use only Manufacturer supplied or equivalent replacement parts.
4. Do not transport CartManager XD+ with hood up.
5. Batteries emit hydrogen gas. When charging, keep away from sparks or open flame and keep hood open.
6. The battery charger supplied with CartManager XD+ shall be grounded while in use to protect the operator from electric shock. Make sure the charger is connected to an outlet having the same configuration as the plug. No adapters should be used with this charger.

CartManager XD+ Views

CartManager XD+ Rear View

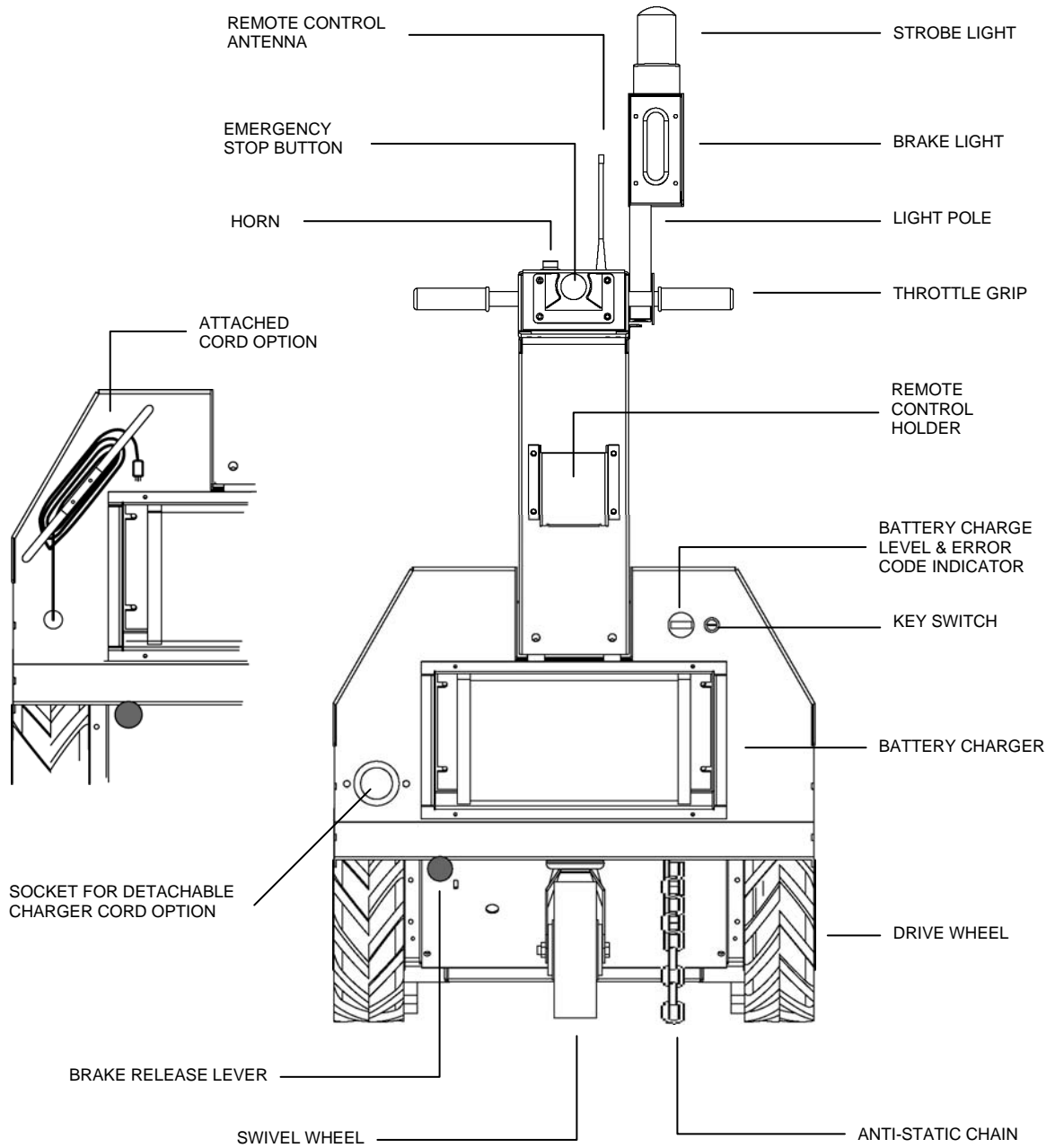

CartManager XD+ Side/Front View

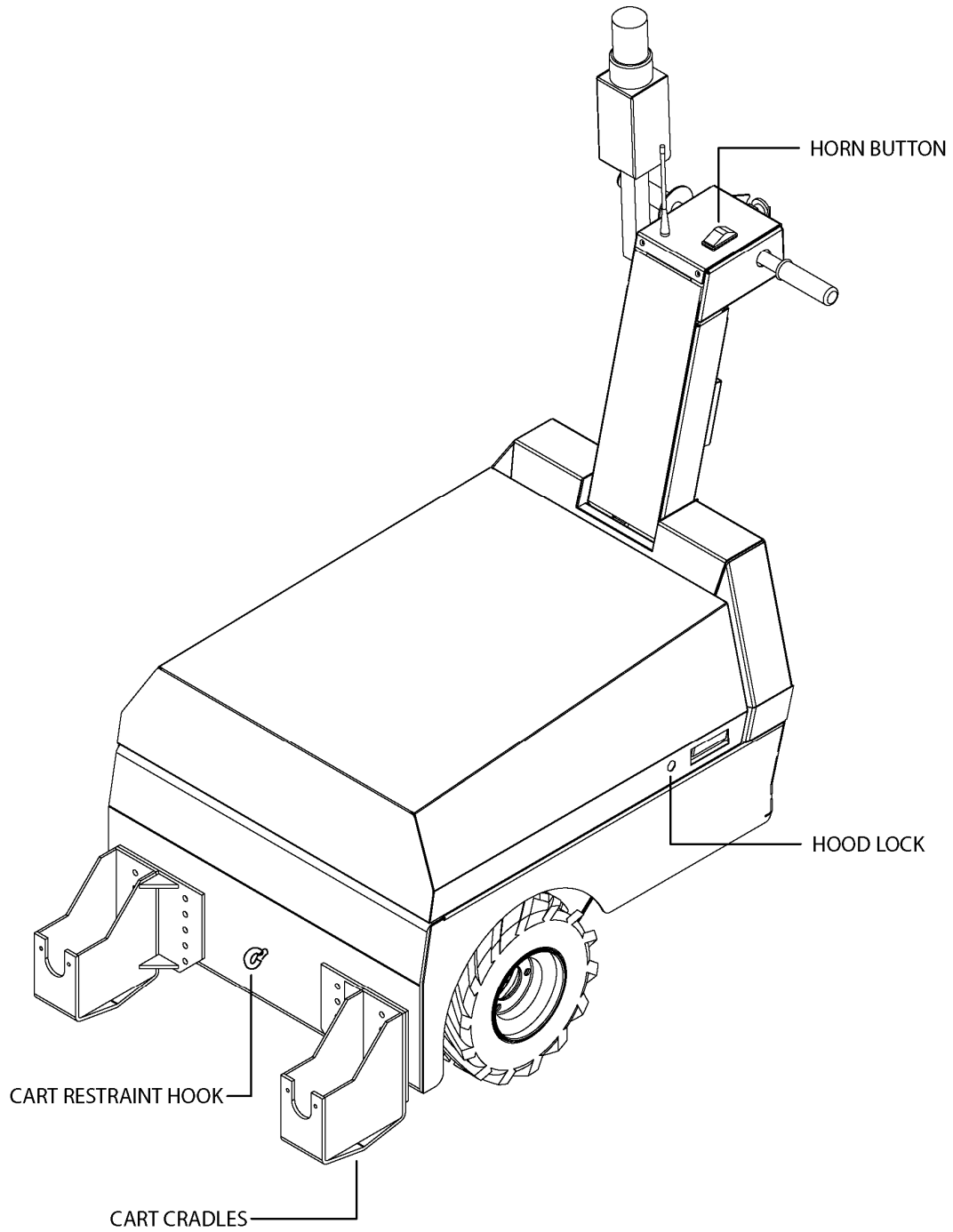

CartManager XD+ Front Access Panel

The Front Access Panel protects the fuse block and controller electronics. The access panel can be easily removed to check for burnt out fuses in the event that CartManager XD+ will not power up or move. This procedure should only be performed by persons who have been trained in basic CartManager XD+ maintenance.

To remove the front access panel:

1. Make sure CartManager XD+ is unplugged.
2. Use a coin or large flat head screwdriver to unlock the hood lock.
3. Grasp one of the inset handles on either side of the hood and lift the hood so that the hydraulic arms lock firmly in place.
4. Use a #2 Phillips head screwdriver to loosen and remove the two screws indicated in the diagram below.
5. Slide the access panel straight up and off. You may need to move the black plastic hose that protects the electrical cables.
6. Perform whatever work is required.
7. Replace the front access panel, making sure that the hose protecting the electrical cables is not pinched by the panel.
8. Grasp one of the handles on either side of the hood and close the hood. **DO NOT** close the hood by pulling on the top edge. You will pinch your fingers.



Front access panel screws

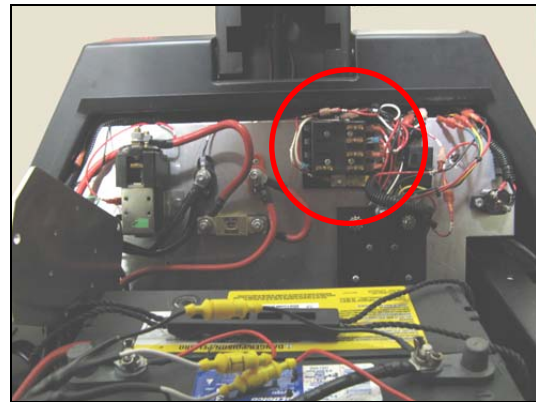

Fuse block behind front access panel

CartManager XD+ Features and Controls

This table provides a description of each of the parts shown in the preceding diagrams.

PART	DESCRIPTION
Antenna	Receives signals from the remote control.
Anti-Static Chain	The anti-static chain prevents damage to the CartManager XD+ electrical components by dissipating static electricity buildup. DO NOT DETACH THIS CHAIN.
Battery Charger	Controls and monitors the battery charging process. LEDs on the charger show charging status and also serve as warning indicators if the charger is malfunctioning.
Battery Discharge Indicator and Fault Indicator	Shows the percentage of charge left in the batteries. You should recharge the batteries any time the charge falls below 20%. The unit can also be plugged in between runs to keep the batteries "topped off" at full charge. This indicator also provides error codes that can be used to diagnose problems with the CartManager XD+.
Brake Light	Acts like the brake light on a car. Off when CartManager XD+ is moving, on when CartManager XD+ is stopped.
Brake Release	Engages/disengages the manual brake. When the lever is pulled out, the brake is disengaged and CartManager XD+ can be manually pushed without using the drive throttles. When the brake lever is pushed in, the brake is disengaged while the unit being driven using the drive motor and engaged when the unit is stopped. The brake release lever must be pushed in to use CartManager XD+ with the drive throttles or the remote control unit.
Charger Cord/Socket	There are two charger cord configurations for CartManager XD+: <ul style="list-style-type: none"> Attached power cord – this cord is permanently attached to CartManager XD+. To charge, unwrap the cord and plug in to a standard grounded electrical outlet. When done charging, make sure the cord is securely wrapped around the cord hooks on the back of the CartManager XD+. Detachable power cord – plug the flat end of the cord in to the socket on the back of the CartManager XD+. Plug the end with the prongs in to a standard grounded electrical outlet. When not charging, make sure the cord is unplugged from both the wall receptacle and the charger socket and stored in a safe place. The rubber cap on the charger socket should be securely fastened when the charger cord is not attached.
Drive Wheels	Foam filled, heavy tread wheels connected to the drive motor.
Emergency Stop Button	The Emergency Stop Button is a safety feature that stops CartManager XD+ immediately when the button is pushed in. To resume operation, twist and release the Emergency Stop button.
Hood	The hood covers and protects the batteries and the components in the battery compartment. When opening and closing, use the inset handles on either side of the hood. Do not grip the hood by the edge; you could pinch your fingers.
Horn	Press to sound the horn.
Key Switch	Insert the key here to turn CartManager XD+ on and off.
Light Pole	Holds the strobe light and brake light. Swings up for operation and down for getting under low overhangs or doors.
Remote Control Holder	Convenient storage for the remote control unit when it is not being used.
Strobe Light	Flashes as long as the key switch is turned on.
Swivel Wheel	Allows the unit to swivel and turn completely around in its own length. This wheel is not connected to the drive motor.
Throttle	Twist forward to move the CartManager XD+ forward, back to go in reverse. The farther you twist the throttle, the faster the unit will move. You also use these handles to steer the unit when in manual drive mode.

Operator Training

All CartManager XD+ operators must be at least 16 years of age and in compliance with any applicable licensing laws for your city, county or state in which CartManager XD+ is being operated.

Any person operating CartManager XD+ must read the material in this training guide, practice the manual exercises, and satisfactorily complete the post-training quiz before using CartManager XD+ for cart retrieval.

This training guide provides instruction on using the Gatekeeper Systems CartManager XD+ for retrieval of shopping carts. While working through this guide, you will complete the following tasks:

- Familiarize yourself with the **Features and Controls** of the CartManager XD+.
- Perform a **PreOperations Check** on CartManager XD+.
- Practice driving CartManager XD+ using the **manual controls**.
- Practice driving CartManager XD+ using the **remote control unit**.
- Practice **retrieving carts**.
- Review the **Safety Guidelines and Operating Tips**.
- Take the post training quiz.
- Go over the quiz with your manager.

For purposes of this training guide, the terms “supervisor” or “manager” shall mean the direct supervisor or manager (or their designated representative) of the prospective operator.

Getting Started

The first thing to do is get acquainted with the various parts and controls of the CartManager XD+. Take a walk around the unit and identify each of the items shown in the diagrams on pages 3 and 4. Also review the table on page 6, which describes the function of each part.



When you are finished, proceed to the **PreOperations Checklist** on page 8.

PreOperations Checklist

Run through the tasks listed below. This preop check should be performed each day before CartManager XD+ is taken out for the first retrieval run. The charger cord should be plugged in and the key switch turned off.

If you discover any abnormal or potentially unsafe conditions during this check, DO NOT use the CartManager XD+. Turn the unit off, make sure the Emergency Stop button is pushed in, remove the key and notify your supervisor.

1. Check the Battery Charger on the back of the CartManager XD+. If the charger is a **Minn-Kota** charger and you see any red lights, unplug the charger cord from the electrical receptacle immediately and notify your supervisor.
2. If the CartManager XD+ has a permanently attached power cord, unplug the power cord from the outlet and wrap it securely around the cord hooks on the back of the CartManager XD+. If the cord is a detachable cord, remove from both the wall outlet and the CartManager XD+ socket and store in a safe place. Make sure the rubber cap is secure over the charger socket.
3. Take a walk around the unit and look for any loose or broken parts, leaking fluids, or other indications that there may be mechanical or electrical problems. If any such conditions are found, leave the CartManager XD+ off and notify your supervisor.
4. Make sure that the Light Pole is securely latched in a fully upright position. Check the tires for excessive or uneven tread wear.
5. Unlatch the hood and visually inspect the battery compartment for loose, disconnected or frayed wires, leaking fluids, corroded battery terminals, etc. DO NOT attempt to correct any abnormal findings unless specifically trained and instructed to do so. Close and relatch the hood.
6. Turn the red Emergency Stop Button clockwise, then release. The Emergency Stop Button must be disengaged (pulled out) for to allow CartManager XD+ go move backwards and forwards at normal speeds.
7. Make sure that the Brake Release lever is pushed all the way in.
8. Insert the key in the key switch and turn clockwise one quarter turn. The strobe light should start flashing and the brake light should come on.
9. Check the Battery Level Indicator. If the level is less than 20%, you should turn off the CartManager XD+, plug the power cord into a standard electrical outlet and recharge for at least four hours. If you see an error code and CartManager XD+ will not power up or move and you have been trained to troubleshoot CartManager XD+ problems, work through the CartManager XD+ Troubleshooting procedures starting on page 21. If you have not been trained to troubleshoot CartManager XD+, turn the unit off and notify your manager.
10. Twist the throttle grips gently forward. CartManager XD+ will move forward. Twist the throttle grips backwards. CartManager XD+ will move backwards. There should be no motion when the throttle grips are in the neutral (released) position.
11. Turn on the remote control unit by pressing and immediately releasing the green ON button. The red Power Indicator LED should light up while you are holding the button down, and flash while the unit is on. If the remote control fails to respond, see the Remote Control Issues section on page 22.
12. Press the Slow (turtle) button. The machine should move slowly forward. Release the button to stop the unit. (If CartManager XD+ does not respond to the remote control, see the instructions on the bottom of page 10 for linking the remote control to CartManager XD+.)
13. Press the red OFF button to shut off the remote control.



Once you have completed the checklist, proceed to **Using CartManager XD+ – Manual Mode**.

Using CartManager XD+ - Manual Mode

Now that you are familiar with the parts of the CartManager XD+ and have performed the PreOperations check, its time to learn how to use the machine.

The first task is to drive the CartManager XD+ using the throttle grips. This is referred to as **Manual Mode**, since you are not using the remote control.

Use manual mode when moving the CartManager XD+ with no carts attached. **DO NOT** use manual mode if you have more than 1 cart attached unless you have two persons; one to run CartManager XD+ and a second to steer the carts from the front of the cart line. **NEVER** attempt to steer a line of carts using just the throttle grips.

This part of the training should be done in a open, flat area, free of debris, obstacles, cars and customers. Remove any carts from the cart cradles for now.

1. Stand behind the CartManager XD+, but do not turn the unit on. Make sure the brake release lever is pushed all the way in. Try moving the unit forward or backward. You should not be able to move the unit.
2. Now pull the brake release lever all the way out. This unlocks the brake and lets you move the unit without using the motor. Try moving the unit forward and backward. CartManager XD+ is heavy, so you will need to exert a fair amount of force.
3. Swing the CartManager XD+ in a full circle without twisting the throttle grips or moving the unit backwards or forwards. This technique is good for turning sharp corners and maneuvering in tight spaces.
4. Push the brake release lever all the way in. **The brake release lever must be pushed all the way in before you can use the throttle grips or the remote control to drive the CartManager XD+.**
5. Make sure the Light Pole is secured in the full upright position. Some stores layouts may require that you swing the Light Pole into the down position to pass through low doorways.
6. Insert the key in the key switch and turn clockwise one quarter turn. The strobe light will begin to flash and the red brake light will come on.
7. Press the horn button to alert people in the area that you are going to be moving.
8. Grasp the throttle grips and twist them gently away from you. CartManager XD+ will move forward. The farther you twist the grips, the faster the unit will move. Top speed is a good, fast walk.
9. Release the throttle grips to stop the CartManager XD+.
10. Now twist the throttle grips back towards you. The unit will move slowly in reverse. Make sure that the path behind you is clear!
11. Stop CartManager XD+ and press the red Emergency Stop button in until you feel it click into place. Twist the throttle grips. Note that CartManager XD+ does not move either forward or reverse. This is a safety precaution to stop CartManager XD+ immediately in the event of an emergency.
12. Disengage the Emergency Stop button by twisting in the direction of the white arrows, then letting go.
13. Practice driving CartManager XD+. Also practice turning sharp corners and swinging the unit completely around in its own length with the unit on, but without twisting the throttle grips.



Once you are comfortable moving both forwards and backwards, at slow or fast speed, move on to the next section, **Using CartManager XD+ – Remote Operations Mode**.

Using CartManager XD+ - Remote Operations Mode

In remote operations mode, a handheld remote control unit is used to control the CartManager XD+, instead of the throttle grips. The operator steers from the front of the line of carts.

1. Make sure that the Emergency Stop button on the CartManager XD+ is pushed in. This prevents the unit from unexpectedly moving while you are loading carts.
2. Load one cart onto the cart cradles, as shown in the figure at right.
3. Stand at the back of the CartManager XD+. Disengage the Emergency Stop button.
4. Turn the key switch to the ON position.
5. Take the remote control unit and move to the side of the front of the cart, facing away from the CartManager XD+.
6. NEVER WALK DIRECTLY IN FRONT OF A LINE OF MOVING CARTS!
7. Turn on the Remote Control unit by pressing and immediately releasing the green ON button. The Power Indicator will light while the button is held down, and flash while the unit is on.
8. Press and release the HORN button once or twice to alert persons that you are in the area. If the horn does **not** sound:
9. Turn off CartManager XD+.



10. Turn on CartManager XD+ and immediately press and hold the green ON button for 15-20 seconds. This establishes a new radio link between CartManager XD+ and the remote. You will only need to use this procedure if CartManager XD+ fails to respond to the remote control unit, or if you are using a different remote than the one usually used with the CartManager XD+.
11. With one hand on the front corner of the cart, press and hold the SLOW (turtle) button. The CartManager XD+ will begin to move slowly forward.
12. While holding the slow button down, push the front of the cart away from you. The cart and CartManager XD+ will turn in that direction. Pull the cart towards you to move back the other way.
13. Release the slow button and CartManager XD+ will stop.
14. Now press and hold the FAST (rabbit) button. CartManager XD+ will move forward, but much faster than when in SLOW mode.
15. Practice using the remote control to move a single cart.



When you are comfortable in both slow and fast modes, press the red OFF button to shut down the remote control unit and go on to the next section, **Retrieving Carts**.

Retrieving Carts

This section shows you how to load carts onto the CartManager XD+ and secure them for transport.

1. Use manual mode to drive CartManager XD+ to the area where you are going to start retrieving carts.
2. Leave CartManager XD+ on when loading carts, but make sure that you press the red OFF button on the remote during the loading process. This prevents the remote from accidentally moving CartManager XD+ while you are loading carts.
3. Attach the small, spring loaded latch on the Cart Restraint Strap to the Cart Restraint Strap Hook on the lower front section of the CartManager XD+, as shown in the figure at right.



4. Set one cart into the cart cradles. It is helpful to put a small empty box in the cart to hold the cart strap when it's not in use. This prevents the strap from falling on the ground and getting tangled in the drive wheels.
5. Add 8-9 more carts onto the front of the first cart. Make sure the carts are nested snugly without a lot of play between them.
6. Bring the Cart Restraint Strap up and wrap it once around the handle of the cart sitting in the cart cradles.



7. Carry the strap up over the top of the row of carts and pass it under the handle of the lead cart. Do not wrap the strap around the handle.
8. Carry the strap back over the top of the carts and pass it under the handle of the cart in the cart cradles. Keep tension on the strap so that the carts are pulled closely together.
9. Continue this looping process until you can hook the strap securely around one of the cart handles without any slack. With more carts you will use fewer loops. When moving a full line of carts, you will probably only be able to do one loop under the handle of the lead cart.
10. Move to the side of the lead cart. Press and immediately release the green ON button on the remote control unit.
11. Place one hand on the corner of the lead cart and press the SLOW button. The line of carts will move slowly forward.
12. Practice driving carts at both slow and fast speed. Remember that you cannot move CartManager XD+ In reverse when using the remote control.

ALWAYS use the restraint strap if you have ANY carts nested in front of the cart in the cradles.



When you are confident with stopping, starting, moving and steering all 10 carts, continue on to the next section, **CartManager XD+ Safety**.

Safety Guidelines and Operating Tips

This section lists some tips to make your cart retrieval with CartManager XD+ safe and efficient.

- Familiarize yourself with the location and content of the Safety and Warning Labels on pages 39 - 43.
- Close and latch the hood before moving CartManager XD+.
- If using a detachable cord, make sure the cord is unplugged from both the wall outlet and the CartManager XD+ charging socket and stored in a safe place. If the CartManager XD+ has an attached cord, unplug the cord from the wall outlet and wrap securely around the cord hooks on the back of the unit.
- CartManager XD+ should go over the speed bumps and ramps normally found in a parking lot, but it is a good idea to plan your route so that speed bumps are avoided if possible. This is especially true if CartManager XD+ is being used to drive a line of carts. If the cart cradles consistently scrape or bottom out, notify your manager to have the cart cradles adjusted.
- Drive CartManager XD+ only on a solid surface such as asphalt or concrete, not grass or mud.
- CartManager XD+ will work in moderate rain or snow, but should be stored in a protected area between retrieval runs. Note that run time on a single battery charge may be decreased in extremely cold weather.
- If the driving surface is icy, wet or slippery, reduce speed when moving and leave extra distance for stopping.
- When driving a line of carts downhill, leave extra room to stop and stop slowly to avoid placing excessive strain on the Cart Restraint Strap.
- When approaching an area where cars or people are present, sound the horn to let them know you are coming.
- If cars or people are in your line of travel, stop until they have passed. If you must proceed, politely ask them to move aside until you have gone by.
- NEVER walk directly in front of a line of moving carts. Always steer from the side of the lead cart.
- When steering from the lead cart in narrow areas, allow sufficient room so you don't get stuck between the cart line and a wall.
- When moving more than 2 carts in manual mode, you will need two people; one to run CartManager XD+ with the throttle grips and the other to steer from the lead cart. NEVER attempt to move a line of carts in manual mode by yourself.
- NEVER allow anyone to ride on CartManager XD+ or attached carts.
- When you leave CartManager XD+ unattended, ALWAYS remove the keys, press the red Emergency Stop button and make sure the Brake Release lever is pushed in.
- Check that your path is clear before you move CartManager XD+, both in front and behind. ALWAYS pay attention to where you are going.
- Unless specifically directed by your store policy, do not use CartManager XD+ to drive carts directly into a cart holding area. Stop CartManager XD+, off load the carts and move them in by hand.
- If you do drive carts directly into a cart storage area with a low opening, unclamp the Light Pole and swing it into the down position before moving through the opening.
- CartManager XD+ is designed for pushing shopping carts. Using the unit for any other purpose may cause injury or damage and will void the warranty.
- Never operate the CartManager XD+ in a negligent, unsafe or inappropriate manner, in other than full compliance with applicable laws, regulations, and the guideline set out in this training guide.
- DO NOT operate the CartManager XD+ if you are taking any medication known to cause impairment of vision, reflexes or judgment, are overly fatigued, or have any other circumstances that would prevent safe use of the unit.

Disregarding any of these warnings may cause injury, severe damage, or even death to you, other employees, customers, the building, other property (including merchandise), equipment, vehicles, or the CartManager XD+ itself.

Gatekeeper Systems Inc. assumes no liability for any consequences arising from use of the CartManager XD+ in any manner other than full compliance with the instructions set forth in this training manual, or in disregard of any of the warnings contained herein.

Care of the CartManager XD+

Charging the CartManager Batteries

CartManager uses 3 heavy-duty 12 volt batteries for a full output of 36 volts.

The batteries are fully charged when the 3 green LEDs on the back of the battery charger show a steady green. Note that the battery charge indicator may initially show 100%, even though the batteries are not fully charged.

The batteries are charged by plugging the charger cord on the back of the CartManager XD+ into a standard grounded (three prong) electrical outlet.

CartManager XD+ will operate for approximately 8-10 hours on a full charge. Recommended procedure is to plug CartManager XD+ in at the end of each work day and leave it to charge overnight (8 hours). It is also a good idea to plug CartManager XD+ in between runs. This type of intermittent charging will not harm the batteries.

To charge the CartManager XD+ Batteries:

1. Drive CartManager XD+ to a clean, dry, well ventilated area, close to a standard grounded (three prong) electrical outlet. This charging area should be sheltered from the weather and out of the way of customer traffic.
2. Turn CartManager XD+ off and remove the key.
3. Make sure that the Emergency Stop Button and Manual Brake Lever are both pushed in.
4. If using a detachable cord, plug the flat end into the charging socket on the back of the CartManager XD+. Plug the end with the prongs into a standard grounded electrical outlet. If the charging cord is permanently attached to CartManager XD+, unwrap the charging cord and plug directly into the electrical outlet. DO NOT use adapters that bypass the grounding prong and allow the cord to be plugged in to a two-prong outlet. If an extension cord is used it must be at least 10 gauge and not more than 10 feet in length.
5. When charging is complete, or CartManager XD+ is needed for cart retrieval, unplug the cord from the wall outlet. If the cord is detachable, unplug it from the charging socket on the back of the CartManager XD+ and store in a safe place. If the cord is permanently attached to the CartManager XD+, wrap it securely on the cord hooks on the back of the unit.
6. If an extension cord was used, make sure it is stored so that it does not present a tripping hazard.

CartManager XD+ Maintenance

This section details maintenance procedures that should be performed on a daily and quarterly (every 3 months) basis.

Safety Precautions:

- Never perform maintenance or troubleshooting procedures for which you have not been trained.
- It is always a good idea to have a partner when doing any procedures (replacing a wheel, changing a battery, etc.) on the CartManager XD+. If this is not possible, at least have someone within calling distance so you can get assistance if you run into trouble.
- Always wear appropriate safety gear such as safety glasses and rubber gloves when cleaning or replacing the main batteries.

Daily/Weekly Maintenance:

- Perform the checks shown on the **CartManager XD+ PreOperations Checklist** located inside the hood of the CartManager XD+ before the first run of the day.
- The outside of the CartManager XD+ can be washed just like a car; use a mild solution of dish detergent and a soft rag. Rinse with clear water. It is important to wash or at least thoroughly rinse CartManager XD+ on a weekly basis during seasons where de-icing chemicals or solvents are being used in the cart collection area.

Quarterly Maintenance:

1. Clean the battery cables and connectors:
 - Put on rubber gloves and safety goggles.
 - Disconnect the battery cables from one of the main batteries and remove the battery from the CartManager XD+.
 - Clean the terminals with a solution of 1 tbsp of baking soda to one cup of warm water.
 - Use a wire brush or medium sandpaper to remove any corrosion or buildup.
 - While the battery is out, buff the cable connectors down to bare metal with sandpaper, a wire brush or a wire wheel.
 - Use a clean dry cloth to wipe the connectors and terminals.
 - Replace the battery, reconnect cables and tighten all connections.
 - Spread a thin layer of waterproof grease over the terminals and connectors.
 - Replace the plastic terminal covers.
 - Repeat this process for the next battery.
2. Check each battery for leaks or cracks in the casing. If there is any fluid leaking from a battery, it should be replaced immediately. See **Replacing the CartManager XD+ Batteries** on page 28.
3. Check all fasteners and hardware. Tighten any loose items.
4. Apply axle grease to the rear swivel wheel bearings.

Post Training Quiz

Take the following short quiz to make sure that you know how to safely operate the CartManager XD+. When you are done, review the quiz with your manager. Go over any questions you missed or answers that you are unsure of. You should also ask your manager or a designated representative to observe you while you are performing cart retrieval using both manual and remote modes.

Successful completion of this quiz indicates that you have read and understand the material contained in this training manual. Gatekeeper Systems does not guarantee the skill or ability of cart operators.

True/False

- _____ 1. CartManager XD+ is used to pull a line of shopping carts.
- _____ 2. It is not necessary for a person to complete the CartManager XD+ training before they use CartManager XD+ for cart retrieval, as long as they will only be moving the unit a short distance.
- _____ 3. Before turning the key to start the CartManager XD+, you should make sure that the power cord has been unplugged and securely wrapped around the cord hooks on the back of the unit.
- _____ 4. If you discover any unsafe conditions when doing the PreOperations check or while using the CartManager XD+, you should continue using CartManager XD+ and tell your manager at the end of the day.
- _____ 5. The red Emergency Stop Button must be pulled out for normal operation of the CartManager XD+.
- _____ 6. The Brake Release lever must be pushed in when using CartManager XD+ with the drive throttle or the remote control unit.
- _____ 7. If the battery level indicator is 20% or less, CartManager XD+ should be charged before using.
- _____ 8. The operator should steer a line of carts by walking directly in front of the lead cart.
- _____ 9. To turn on the remote control unit, press and then immediately release the green ON button.
- _____ 10. The Cart Restraint Strap is only necessary if you are moving more than 5 carts.
- _____ 11. CartManager XD+ can be driven with the hood open, as long as it is only a short distance.
- _____ 12. The large tread on the CartManager XD+ drive wheels makes it OK to drive through the mud or on grass.
- _____ 13. CartManager XD+ can be used in rain or snow, so long as the conditions are not so severe as to be unsafe.
- _____ 14. When driving a line of carts downhill, or in wet or slippery conditions, you should reduce speed and allow extra distance for stopping.
- _____ 15. When approaching an area where customers or vehicles are in your line of travel, you don't need to stop, as long as you sound the horn to let them know you are coming.
- _____ 16. If you are using the remote control to drive carts into a narrow area such as a hall or aisle, where you cannot steer from the side of the lead cart, you should stop CartManager XD+ and move the carts manually to the cart storage area.
- _____ 17. It is OK for a single operator to move a line of carts using just the throttle grips on the back of the CartManager XD+.
- _____ 18. You can let someone ride on the CartManager XD+, as long as there are no carts attached.

True/False

_____ 19. CartManager XD+ should be turned off and the keys removed from the keyswitch whenever the machine is left unattended.

_____ 20. The battery charging area should be clean, dry and well ventilated.

_____ 21. The batteries are fully charged when all three green LEDs on the battery charger show a steady green.

_____ 22. It is OK to use an adapter that converts the three prong plug on the CartManager XD+ cord for a two prong electrical outlet.

_____ 23. You should never operate CartManager XD+ if you feel that you cannot do so in a safe and responsible manner.

Quiz Answers

The following section provides the correct answers for the post training quiz, as well as the rationale for the correct answer and a page reference indicating where the information is given. The operator and supervisor should go over the answers together. Any incorrect answers should be discussed and clarified until the operator is clear on the procedures and safety issues involved.

The operator should also be observed performing the various hands-on CartManager XD+ functions such as using the CartManager XD+ in both manual and remote modes, securing and moving carts, and following all safety precautions.

Once the supervisor is satisfied that the operator is able to use CartManager XD+ in a safe manner, the operator may be allowed to perform cart retrieval duties.

1. F CartManager XD+ is used to push a line of carts for cart retrieval. (page 7)
2. F Any person using CartManager XD+ must complete the training material contained in this guide. (page 7)
3. T Confirming that the cord is secured and wrapped before moving CartManager XD+ prevents potential damage to the cord and electrical outlet. (page 8)
4. F If you discover any abnormal or unsafe conditions, you should report them to your manager before using CartManager XD+. (page 8)
5. T The Emergency Stop Button should be pulled out during operation so that CartManager XD+ can move forward and back at normal operating speeds. (page 9)
6. T The brake release lever should only be pulled out if you are going to physically push the CartManager XD+ for some reason. (page 9)
7. T If you start a cart retrieval run on less than 20% charge, there is a chance you could run out of power in the middle of the cart collection area. (page 8)
8. F When steering a line of carts, you must stand to the side of the lead cart. Standing directly in front of the cart line could lead to injury if the carts come loose or the line fails to stop. (page 10)
9. T The remote control unit is turned on by pressing and immediately releasing the green ON button (page 10). Note that this is different from linking a remote to a CartManager XD+ unit.
10. F The cart restraint strap must be used any time there is more than one cart in the line.
11. F Driving with the hood open may cause injury if the hoods slams shut while the CartManager XD+ is being moved. (page 13)
12. F CartManager XD+ should only be driven on solid surfaces such as asphalt, concrete or hard packed earth. (page 13)
13. T CartManager XD+ is sealed against normal-to-moderate weather conditions. If weather conditions are extremely severe or unsafe, you should delay cart retrieval until conditions improve. (page 13)
14. T Driving carts downhill or on slick surfaces requires extra distance. (page 13)
15. F Customer and other vehicles ALWAYS have the right of way. If customers or vehicles are in your path, sound the horn and politely request that they move aside until you have safely passed. (page 13)

16. T Driving carts through a narrow area increases the potential for injury if the operator gets caught between the line of moving carts and a wall. (page 13)
17. F Always use two persons when using the throttle grips (instead of the remote) to move more than 1-2 carts. NEVER attempt to steer a line of carts with just the throttle grips. (page 13)
18. F NEVER allow anyone to ride on the CartManager XD+ or in the shopping carts. (page 13)
19. T Leaving the keys in the keyswitch when CartManager XD+ is unattended may lead to injury or damage if an untrained person starts playing with the unit. (page 13)
20. T Battery charging should always be done in an area that is clean, dry and well ventilated.
21. T The batteries are fully charged when the green LEDs on the back of the battery charger show a steady green. (page 15). The battery charge indicator may read 100% at the beginning of a charge, even though the batteries are not fully charged.
22. F NEVER use an adapter that bypasses the grounding prong on the charger cord. To do so increases the possibility of electrical shock. (page 15)
23. T Operating CartManager XD+ when you are not safely able to do so may result in injury to yourself or others, or damage to property. (page 15)

Troubleshooting

This section details some simple troubleshooting routines.

Follow the diagnostic and repair steps listed in each section exactly as they are written, making sure to observe good body mechanics, basic safety practices, and any guidelines that are specific to your store location.

DO NOT perform any troubleshooting or maintenance procedures unless you have been properly trained and given permission by your supervisor.

If you are still experiencing difficulties after completing the troubleshooting tasks, please refer to the last page in this guide for information on contacting your nearest Gatekeeper Systems regional Customer Support center.

Remote Control Issues

Changing the Remote Control Batteries

Follow these steps to change the batteries in the remote control unit:

1. Peel back one edge of the rubber sleeve surrounding the remote control unit and remove the unit from the sleeve.



2. Turn the unit over to expose the battery compartment cover.



3. Remove the old battery and replace with a similar 9 volt battery.
4. Replace the battery compartment cover and protective sleeve.



Remote Control Does Not Work

Use this process to diagnose and correct problems when the remote control unit either does not turn on, or turns on but does not communicate with CartManager XD+.

If you are using a new remote for the first time, or using a remote other than the one usually used with a particular CartManager XD+ unit, follow the steps in the **Link the remote to CartManager XD+** flow below to set up a communications link between the remote and the CartManager XD+ unit.

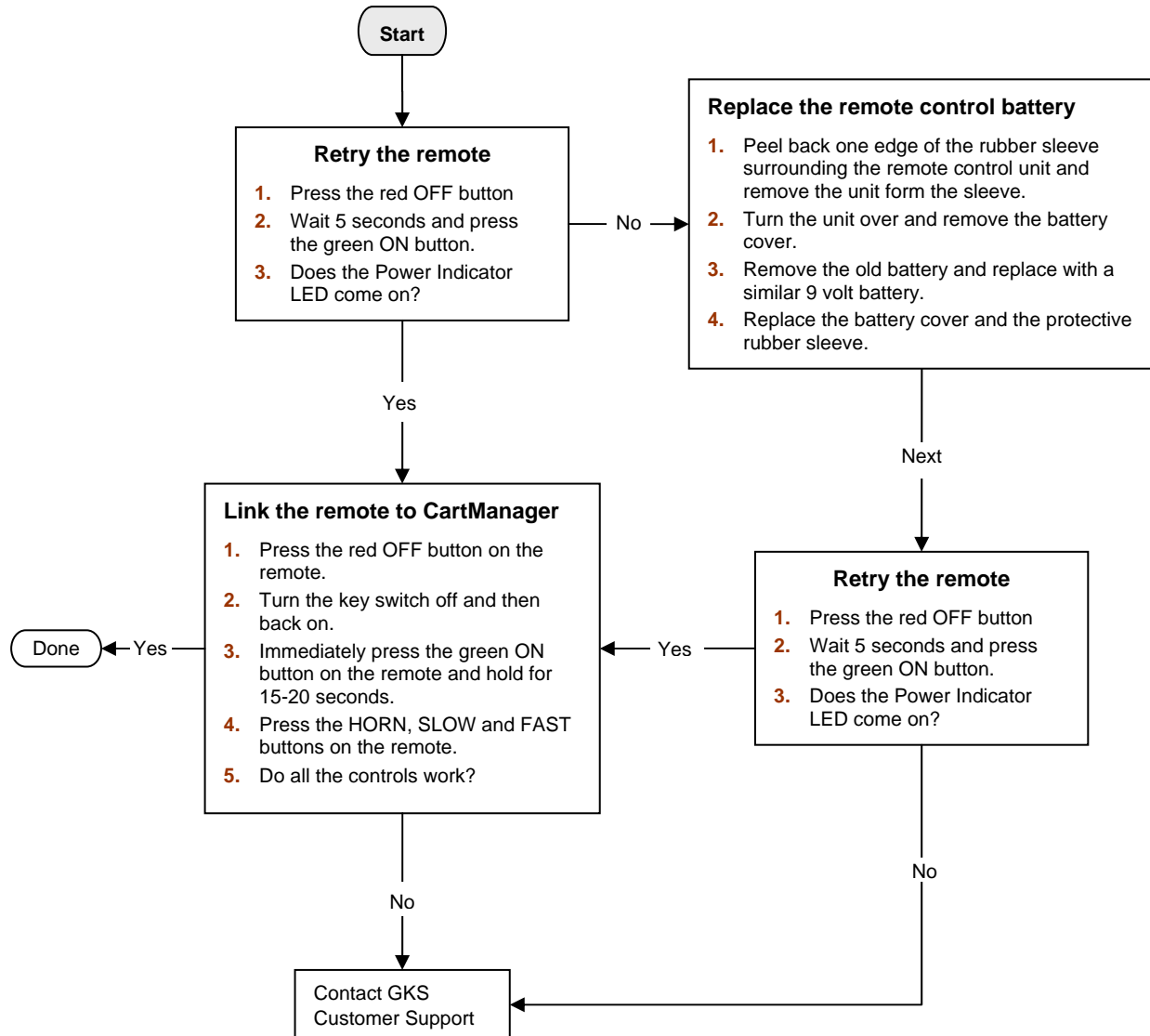

Electrical Issues

CartManager XD+ Does Not Turn On

Use this troubleshooting flow if nothing happens (no lights, no horn, no movement) when the keyswitch is turned on.

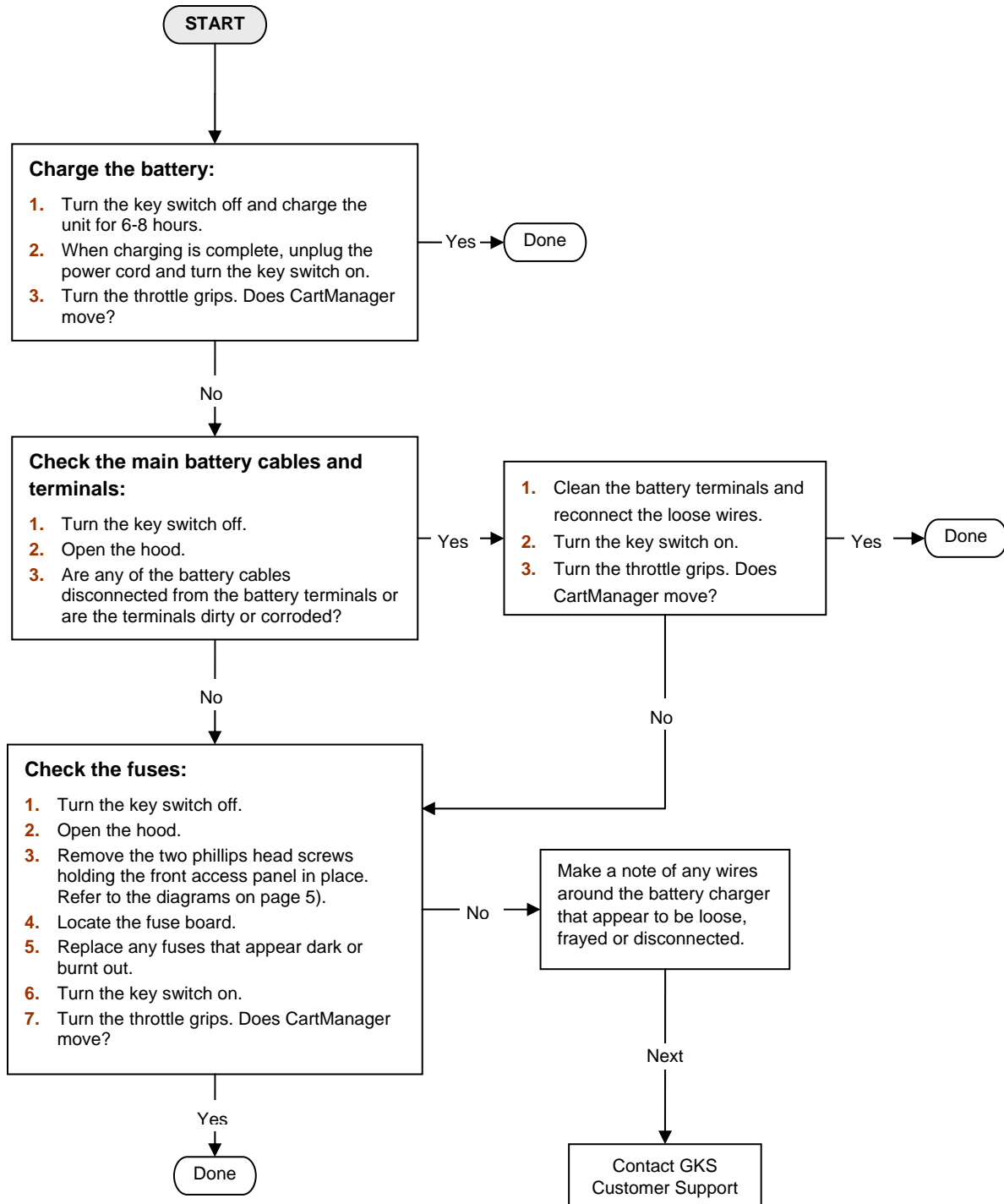

CartManager XD+ Does Not Move

Follow the steps below if the lights go on when you turn the keyswitch, but CartManager XD+ does not respond when you turn the throttle grips. If CartManager XD+ moves when you turn the throttle grips, but does not respond to the remote control, see **Remote Control Issues** on page 23.

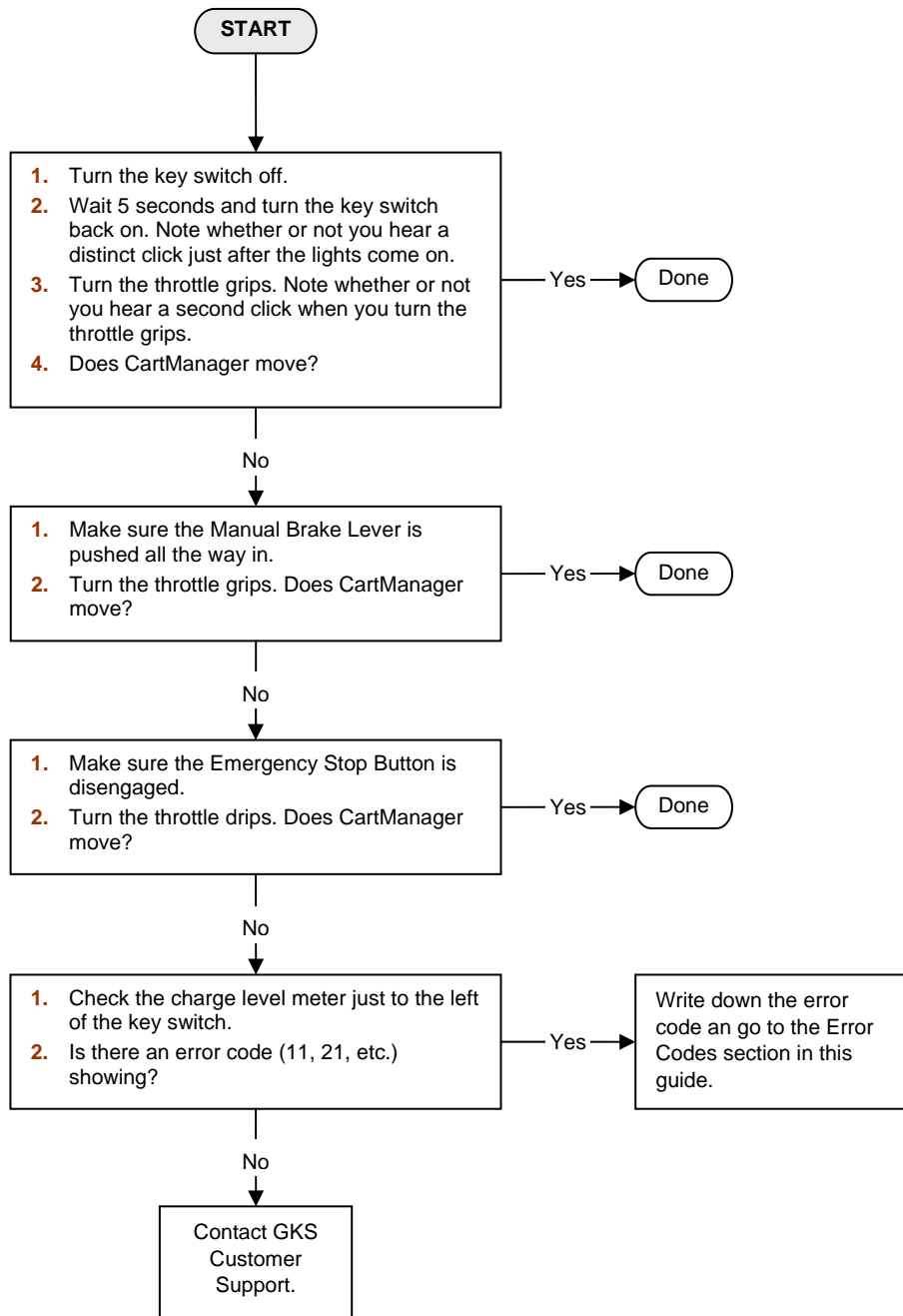

Battery Issues

CartManager XD+ is powered by three heavy duty, rechargeable, 12 volt batteries. The batteries are located under the hood in the front section of the CartManager XD+ and are sealed so there is no need to add fluid to the cells. Regular maintenance consists of checking for leaks and loose connections on a daily basis, and cleaning the terminals and battery connectors every three months.

The diagram below shows the placement of the batteries, main cables and charging cables with inline fuses. Several of the tasks in this section will refer back to this diagram.

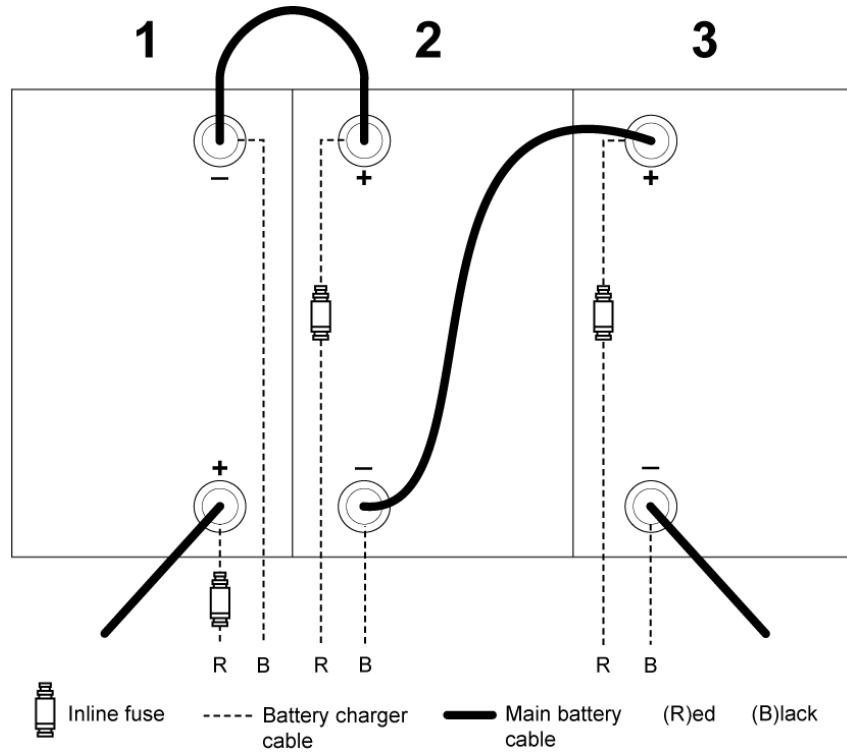

The **battery charger**, located on the back of the CartManager XD+, takes regular current from the wall outlet and converts it to charge the batteries. Your CartManager XD+ will have either a 110 volt charger or 230 volt charger. Both types are pictured below.



110 volt battery charger



230 volt battery charger

Battery Chargers

The symptoms of battery charge malfunction will differ depending the type of charger in your particular CartManager XD+:

For 110 volt chargers:

LEDs - the charger has three LEDs; red, yellow and green, for each of the batteries in CartManager XD+. Only one of these LEDs should be illuminated at a time.

Red – indicates a short circuit, blown inline fuse, reverse polarity (charger hooked up backwards to the battery), or battery under voltage (less than 8 volts). If the red LED is illuminated while the battery is connected, immediately disconnect from the AC power and check the battery connections. The Red LED will also illuminate if a battery is not connected to the DC battery leads.

Yellow – indicates the battery charger is in bulk charging mode. This LED will be on until the battery is approximately 90% charged.

Green – indicates that the battery is over 90% charged and is being maintained. Once the battery reaches full charge, the Green LED will stay illuminated until the charger is unplugged.

Inline fuses – inline fuses near the terminal end of each positive (red) DC lead serve as protection from extreme voltage surges or lightning strikes. If a fuse blows, replace it with the exact type and rating of the original fuse. Improper battery connections will normally not cause a fuse to blow since this is handled by the charger's internal circuitry.

Note that the charger cannot charge a battery that is damaged or has been discharged to less than 8 volts.

For 230 volt chargers:

1. With the key switch off, plug in CartManager XD+ to an electrical outlet.
2. The top of the battery charger displays three sets of lights; one set for each battery. The left-hand set is for battery number one, the middle set for battery number two and the right-hand set for battery number three. These lights monitor the progress of the charging process. The normal sequence of lights is:
 - The red LED will start flashing as the unit begins to charge.
 - Both red and green LEDs will flash during the middle of the charging process.
 - At the end of the charging process, the red LED will go out and only the green LED will be lighted.
5. If the red LED for a battery stays lit for more than 24 hours, it means there is a problem with that battery:
 - Remove the charger plug from the electrical outlet and notify your supervisor.
6. If the green AND red LEDs stay on for more than 24 hours:
 - If you are using an extension cord, remove it and plug CartManager XD+ directly into the electrical outlet.
 - If the red and green LEDs persist, remove the charger plug from the electrical outlet and notify your supervisor.
7. If the green LED stays on, even when the battery charge is low:
 - Remove the charger plug from the electrical outlet.
 - Check the inline fuses on each of the red battery charger cables; replace any blown fuses.
 - Plug the charger cord into the electrical outlet. Charging should proceed as usual.
8. If neither the red nor the green LED lights when the charger cord is plugged in:
 - Make sure that the charger plug is firmly seated in the electrical outlet.
 - If the charging indicators still do not light, try a different electrical outlet.
 - If the lights still do not light, unplug the unit and notify your supervisor.

Battery Runs Down Quickly

CartManager XD+ should operate for 8-10 hours on a full charge, which is indicated by all green lights on the battery charger. This time may be decreased if CartManager XD+ is being used on inclines such as hills or ramps; if carts are loaded during collection runs, or if the batteries are faulty. If the charge level indicator consistently reads low after less than 8 hours of use, check the following:

1. Open the CartManager XD+ hood and check all battery connections and terminals. Clean any that are dirty or corroded, using the procedure on page 15.
2. Tighten any loose connections.
3. Check for any leaks around the bases of the batteries. If you find leaks, replace the faulty battery as per the directions in the Replacing CartManager XD+ Batteries section below.
4. If the problem persists, contact Gatekeeper Systems Customer Support.

Replacing CartManager XD+ Batteries

If you find a leaking battery or you suspect that the battery is faulty, the battery should be replaced. Running CartManager XD+ with a faulty battery will damage the battery charger and may result in injury or damage due to leaking battery acid.

You will need:

- Replacement 12 volt, heavy-duty, maintenance free, deep-cycle battery; part #E500155-04,
- A 1/2" (13 mm) socket, driver and short extension,
- Several clean, dry cloths,
- If the battery is leaking, a pan or tray to put it in,
- Safety goggles and rubber gloves,
- Lightweight waterproof grease.

1. Park CartManager XD+ in a clean, dry, well-ventilated area. Do not plug in the charger cord.
2. Put on the gloves and safety goggles.

BATTERY ACID CAN CAUSE SEVERE BURNS TO SKIN AND EYES! IN CASE OF CONTACT, RINSE IMMEDIATELY WITH LARGE AMOUNTS OF RUNNING WATER.

3. Note the position of the battery in the compartment and the arrangement of the wires connected to it. If necessary, use pieces of masking tape or sticky notes to label the wires.
4. Use the 1/2" (13 mm) socket to completely disconnect all cables from the battery being removed. If replacing multiple batteries, do one at a time to avoid mixing up the cables when you reconnect them.
5. Lift the battery carefully from the battery compartment and place in the tray. These batteries are heavy; be sure to use good body mechanics and observe proper safety precautions when handling the battery.
6. Place the new battery into the battery compartment with the terminals in the same orientation as the battery you just removed. If in doubt, check the diagram on page 25.
7. Make sure the battery terminals and connections are clean and dry. If the connecting cables are dirty or corroded, clean them following the procedure on page 15.
8. Reconnect the new battery. Securely tighten all connections and apply a light coat of waterproof grease.
9. Dispose of the old battery in accordance with your store policy on handling hazardous waste.
10. Plug CartManager XD+ in and allow to charge overnight (8 hours).
11. If any battery acid has splashed on clothing, soak thoroughly with a solution of 1 tablespoon baking soda per 1 cup of water. Rinse well with running water.

Battery Indicator

When the CartManager XD+ is turned on, the battery indicator displays various information, including the percentage of charge left in the battery, the total amount of time the unit has been used since leaving the factory, and diagnostic fault codes.

Depending on the status of the emergency stop button when the CartManager XD+ is turned on, different information appears in the LCD display.

- If the emergency stop button is not pressed in, the amount of charge left in the battery appears in the LCD display and the BDI (Battery Discharge Indicator) is illuminated.
- If the Emergency Stop Button is pressed in, the hourmeter LED is on, and the hourmeter data (the total amount of time the unit has been used since leaving the factory) displays. The hourmeter value displays on the LCD for a period of less than five seconds; the LCD will then change its display to show the amount of charge left in the battery.

If the CartManager XD+ is turned on and there is an operating problem, the fault LED illuminates and a fault indicator code appears in the LCD display. The unit will not work until the operating problem has been resolved.

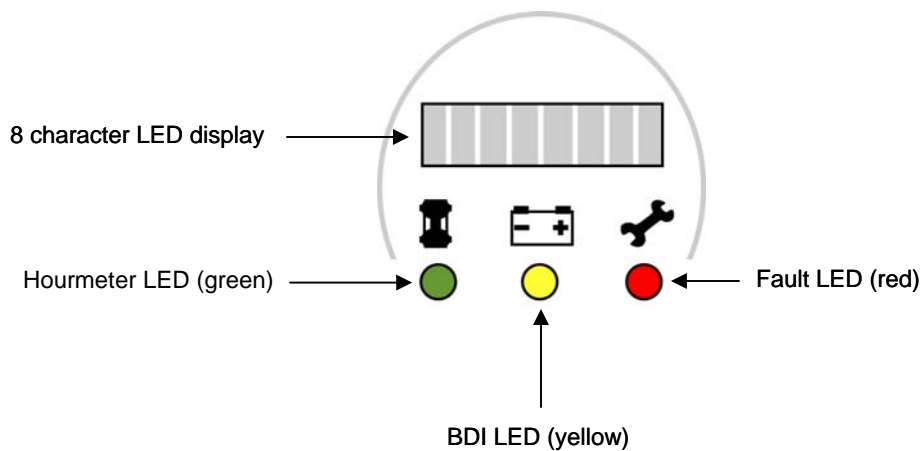

ITEM	DESCRIPTION
8 character LED display	Displays remaining battery charge or an error code.
BDI LED	Flashes when the LED display is showing the remaining battery charge.
Fault LED	Flashes when the LED is displaying an error code.
Error Codes	When an error occurs, the BDI will display either an error code (example: CODE 23) or flash a series of lights that corresponds to an error code. An example of the flashing code would be two flashes followed by three flashes, which would indicate error code 23.

Error Codes

An error code is a two-digit code that appears in the battery charge level indicator LED when there is an electrical malfunction in the CartManager XD+.

When you turn on the keyswitch, CartManager XD+ runs through a brief diagnostic routine. If there are no electrical malfunctions detected, the battery level indicator LED will display the remaining battery charge (example: 93%). If an error is detected, the battery level indicator will give the number of the error (example CODE 23).

If you are having problems with CartManager XD+ and an error code displays, find the corresponding section below and follow the instructions for diagnosing and possibly correcting the problem.

Error Code 01

This error code indicates that the CartManager XD+ diagnostics system does not detect an electrical malfunction. If you have run through any applicable troubleshooting flowcharts earlier in this guide and continue to have problems with CartManager XD+, contact Gatekeeper Systems Customer Support.

Error Code 11,12,13

There may be a transient electrical spike or other problem:

1. Turn the key switch off.
2. Open the hood and check for any loose or disconnected wiring.
3. Close the hood and turn the unit back on.
4. If the problem has not been resolved, contact Gatekeeper Systems Customer Service.

Error Code 14

The throttle turned forward or backwards when CartManager XD+ is turned on:

1. Turn the key switch off. Release the throttle to neutral position.
2. Wait 5 seconds and turn the keyswitch back on, making sure not to turn the throttle grips forward or backward until CartManager XD+ is powered up.

Error Code 21, 22

Contact Gatekeeper Systems Customer Support.

Error Code 23

The throttle turned forward or backwards when CartManager XD+ is turned on:

1. Turn the key switch off. Release the throttle to neutral position.
2. Wait 5 seconds and turn the keyswitch back on, making sure not to turn the throttle grips forward or backward until CartManager XD+ is powered up.

Error Code 24, 31

Contact Gatekeeper Systems Customer Support.

Error Code 32, 33, 34

There may be a problem with the main contactor switch:

1. Turn CartManager XD+ off.
2. Wait 5 seconds and turn the unit back on. Listen carefully for a loud click down towards the lower left rear section of the CartManager XD+ as soon as you turn the keyswitch.
3. Contact Gatekeeper Systems Customer Service. Inform them of the error code and whether or not you heard the click.

Error Code 41

There may be a bad battery connection:

1. Turn the key switch off.
2. Release the hood latches and open the hood.
3. Check the battery terminals and connections. If any are loose or corroded, clean and then reconnect them.
4. Charge CartManager XD+ for several hours.
5. Unplug CartManager XD+ from the electrical outlet and turn on.
6. If the error code persists, contact Gatekeeper Systems Customer Support.

Error Code 42

The charger cord may still be plugged in to the electrical outlet.

1. Turn the key switch off.
2. Unplug the charger cord from the electrical outlet and coil securely on the cord hooks on the back of the CartManager XD+.
3. Turn CartManager XD+ on. If the error code persists, contact Gatekeeper Systems Customer Support.

Error Code 43

The temperature inside the CartManager XD+ compartment is outside the safe operating range for the electrical components.

1. Move the unit to a room temperature area and allow to sit for 30-60 minutes.
 2. Turn the key switch on. If the error code persists, contact Gatekeeper Systems Customer Support.
- Suggestions:
 - If CartManager XD+ is sitting for long periods of time in direct sunlight, move to a shaded area when not in use.
 - If the unit is sitting outside in extreme cold (< -25 C) for long periods, move to a warmer area when not in use.
 - If you do a retrieval run and any of the carts are loaded, reduce the number of carts that you drive with the CartManager XD+.

Error Code 44

The motor is too hot:

1. Turn the unit off and allow to sit for 30-60 minutes, preferably in a shaded area.
2. Turn the key switch on. If the error code persists:
 - If CartManager XD+ is sitting for long periods of time in direct sunlight, move to a shaded area when not in use.
 - If you do a retrieval run and any of the carts are loaded, reduce the number of carts that you drive with the CartManager XD+.
3. If the error continues, turn CartManager XD+ off and contact Gatekeeper Systems.

Mechanical Procedures

Replacing the Strobe Light Bulb

You will need:

- A replacement strobe light bulb, part #E500238-02 (Do not remove the new bulb from its protective wrapping.)
 - A pair of pliers or vise grips
1. Park CartManager XD+ and turn the key off.
 2. Grasp the orange strobe light cover with your hand and twist counter clockwise to remove it from the strobe housing.
 3. Grasp the plastic housing on the old bulb just below the two small wings that stick out on either side. You may need to use the pliers or vise grips for this.
 4. Pull firmly to remove the casing from the base. DO NOT pull on the filament, it will break.
 5. Remove the new bulb from its wrapping. Hold the bulb by the plastic portion of the base. DO NOT touch the filament with your fingers; the oil from your skin will substantially decrease the life of the bulb.
 6. Turn the bulb so that the rounded corners on the bulb base match the rounded corners in the bulb socket. Press the casing of the new bulb firmly into the bulb base, taking care not to bend the metal contacts.
 7. Screw the strobe cover back on to the strobe housing.
 8. Turn on CartManager XD+ and confirm that the new strobe is working.

Replacing the Rear Swivel Wheel

You will need:

- 1 wheel assembly, foam filled: part #A500128-03,
 - A car jack, ball jack, pallet jack, or similar type of device capable of lifting at least 750 pounds.
 - 4 wheel chocks,
 - Several sturdy wood blocks
 - A 9/16" (15 mm) socket and driver, and a medium crescent wrench or 9/16" (15 mm) box end wrench.
1. Park CartManager XD+ in a dry, flat area.
 2. Make sure that the brake release lever is pushed all the way in.
 3. Wedge chocks in front and behind both of the drive wheels.
 4. Place the car jack or one tongue of the pallet jack on the metal frame at the back of the CartManager XD+, just to the side of the square metal plate that supports the swivel wheel, as shown in the figure at right.
 5. Raise CartManager XD+ so that the swivel wheel is about 1" (25 mm) off the ground.
 6. Wedge wood blocks under both corners of the bar that supports the swivel wheel plate. Make sure the blocks are the same height on both sides.
 7. Lower CartManager XD+ onto the blocks and remove the jack.
 8. Use the 9/16" (15 mm) wrenches to remove the 4 bolts from the swivel wheel base plate. Save the bolts.

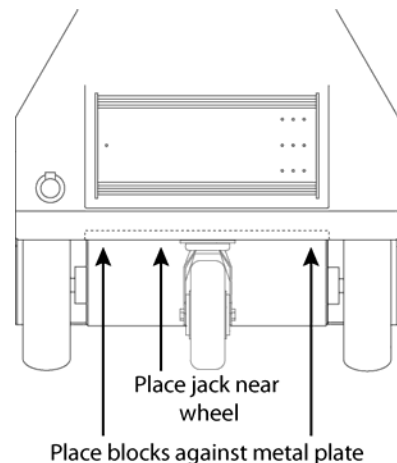

9. Attach the new swivel wheel assembly. Tighten the bolts securely.
10. Place the jack, remove the wood blocks and lower CartManager XD+ back down.
11. Remove all tools and materials from the area.

Replacing the Main Drive Tires

The foam-filled main drive tires are designed to give maximum traction and durability over a wide range of working conditions and surfaces. The only time you should need to replace a tire is in the case of excessive wear or damage. If you need to replace both tires, do them one at a time.

You will need:

- 1 or 2 replacement foam-filled tires, part #A500129,
 - A car jack, ball jack, or similar type of device capable of lifting at least 750 pounds
 - 4 wheel chocks,
 - Several sturdy wood blocks,
 - A 3/4" (19 mm) socket, socket driver and a short extension.
1. Park CartManager XD+ in a dry, flat area.
 2. Make sure the unit is turned off and that the manual brake lever is pushed all the way in.
 3. Wedge a wheel chock in front and in back of the wheel you are NOT working on.
 4. Wedge 2 chocks to immobilize the back swivel wheel.
 5. On the wheel being replaced, use the 3/4" (19 mm) socket to loosen the nuts about 1/2 turn. DO NOT remove the nuts completely.
 6. Place the jack under the side panel on the same side as the wheel being changed, as shown in the diagram below.
 7. DO NOT use a forklift or pallet jack to lift from under the metal shroud that protects the motor and axle assembly; you will damage the shroud.

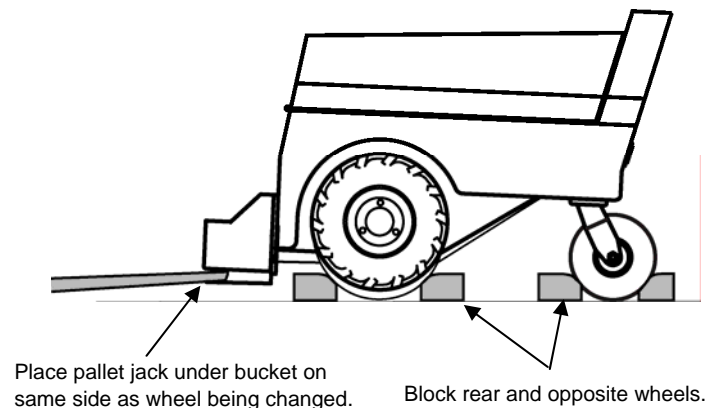

8. Lift CartManager XD+ so that you have just enough room to slide the new tire on.
9. Wedge the wood blocks under the front corner of the CartManager XD+. This provides an extra safety measure in case the jack shifts.
10. Remove the nuts and pull the tire straight off the bolts.
11. Slide on the replacement tire and tighten the nuts.
12. Lower the jack and remove all tools and materials from the area.

Adjusting the Cart Cradles

You will need to adjust the height of the cart cradles on the front of CartManager XD+ if they consistently scrape when going over speed bumps, up ramps, over door sills, etc. You may also need to adjust the distance between the cradles if your store changes to carts with a different width between the back wheels. .

You will need:

- A 1/2" (13 mm) socket, a driver and a long extension.
1. Park CartManager XD+ in a dry, flat area.
 2. Turn the unit off and make sure that the manual brake lever is pushed all the way in.
 3. Remove the cradles. You will see two sets of threaded bolt holes in the front of the CartManager XD+.

Note: the Cart keeper bolts may not be present on your unit if they interfere with the type of cart used at your store.

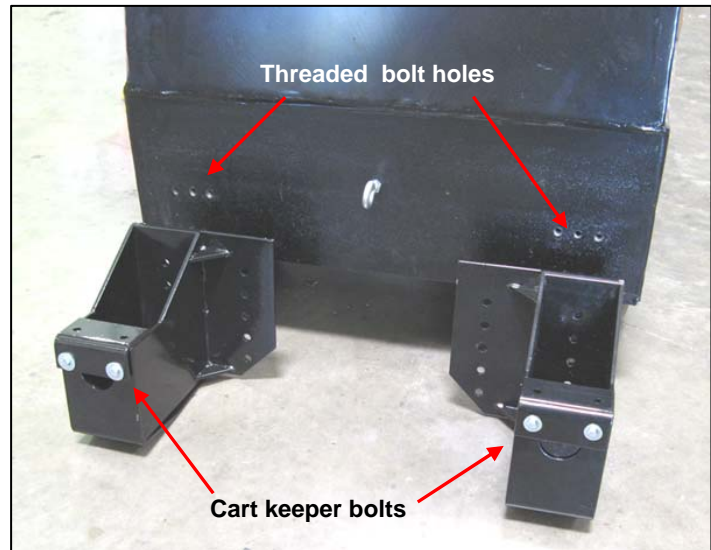

4. Match the holes in the back or in the flanges of the cart cradles with a set of holes on the CartManager XD+. A different set of holes can be used for each side, they don't both have to be the same.
5. Replace the bolts, two for each cart cradle and tighten securely.

Reference

Technical Specifications

Electrical

- Batteries — 36-Volts D.C.; three, marine-grade, maintenance free, group 30, 12-volts batteries, with a 180 minute reserve capacity
- Battery Charger — Marine-grade, 30 Amp charger with automatic peak charge shut off, and trickle charge mode. Water tight enclosure with shock and vibration resistant electronics. Short circuit and reverse polarity protection.
- Motor Controller — Fully programmable controller with output to BDI and diagnostic display. Allows for quick and effect fault identification.

Safety

Features:

- Emergency brake button at manual throttle and on remote
- 100,000 candle power beacon strobe light
- Automatic parking brake
- Red brake light - works in manual and remote operation
- Warning horn in manual and remote
- Automatic low-battery warning
- Automatic overload shutdown
- Programmed acceleration, deceleration and maximum speed for operation control
- All electronics are mounted away from batteries in a separate compartment

Certifications:

- CE approved (conforms to CSA & UL)
- UL or CE approved charger (to standard 1236)
- FCC approved remote control

Operations

- Forward speed: 0-3.5 mph (5.6 Km/h)
- Reverse speed: 0-1.5 mph (2.4 Km/h)
- Remote control and receiver with 200 foot range
- Automatic, self-programming remote control and receiver with 16 million security codes
- Self diagnostics motor controller with output to externally visible, BDI battery indicator/ Diagnostic Meter for easy troubleshooting

Mechanical

- Weight: 696 pounds (316 Kg).
- 12.5" (318 mm) foam filled tire
- Ergonomically correct hand grip throttle control
- 6' (1.83 Meter) charger cord
- Integral motor drive and axle assembly
- Pressure sealed transaxle and differential to prevent water or debris intrusion
- Drive controller and all electronics are fully shielded from environmental hazards and unexpected impacts
- Integrated, adjustable, automatic electro-magnetic braking
- Charger is isolated from rest of the batteries, electronics and motor controller

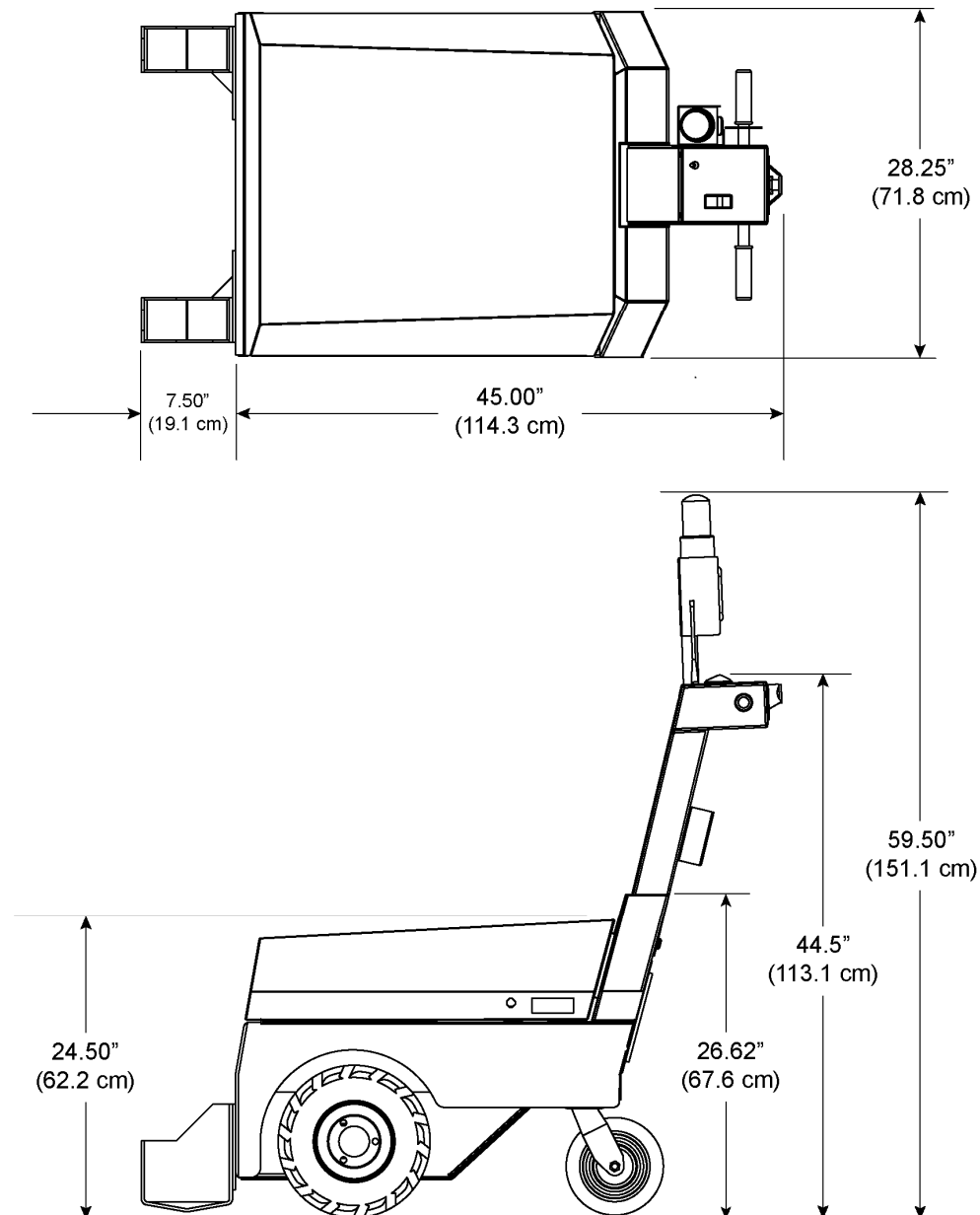

Wiring Diagrams

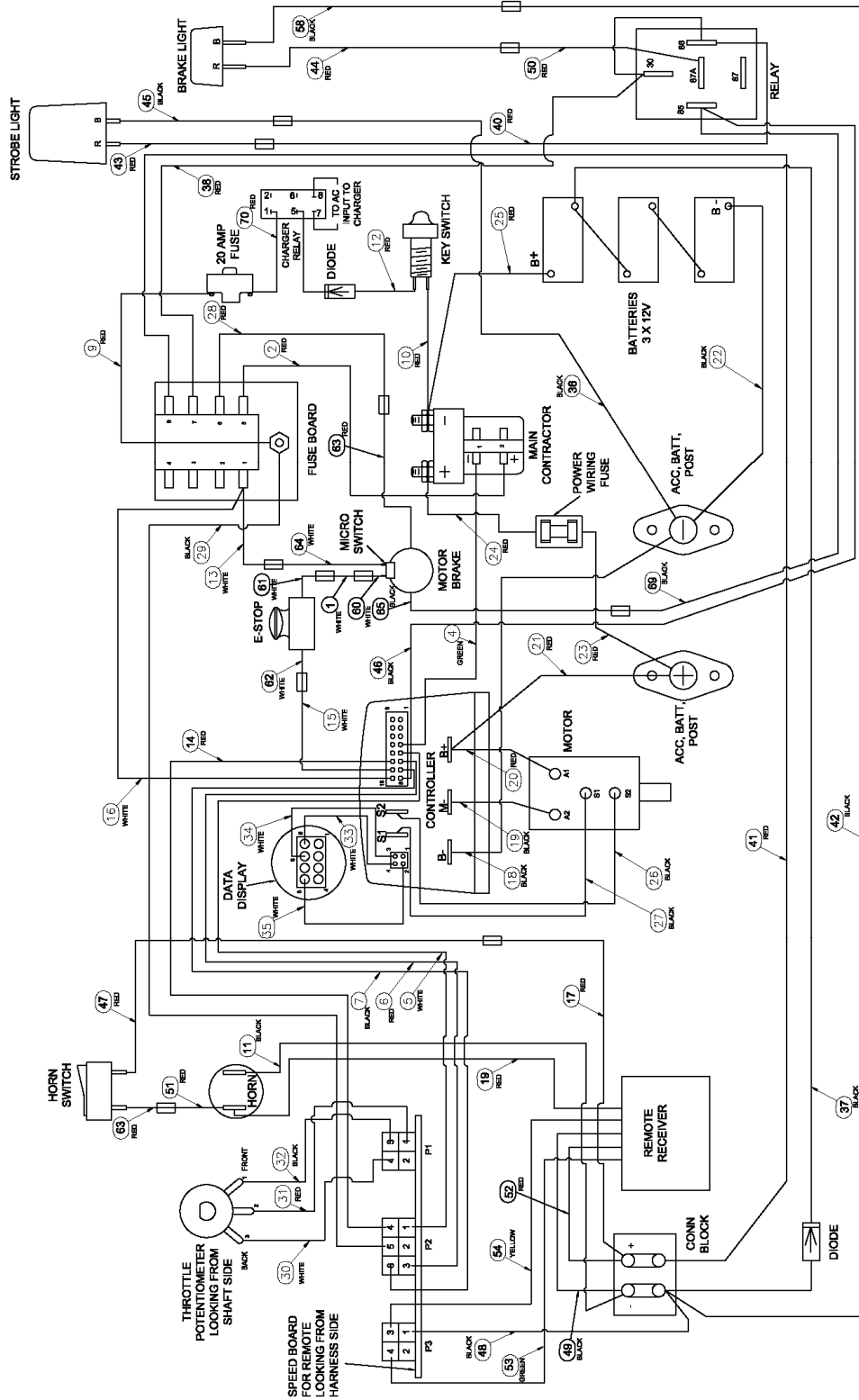

Safety and Warning Labels

This diagram shows the placement of the various safety and warning labels on CartManager XD+. The actual labels are shown on the following pages.

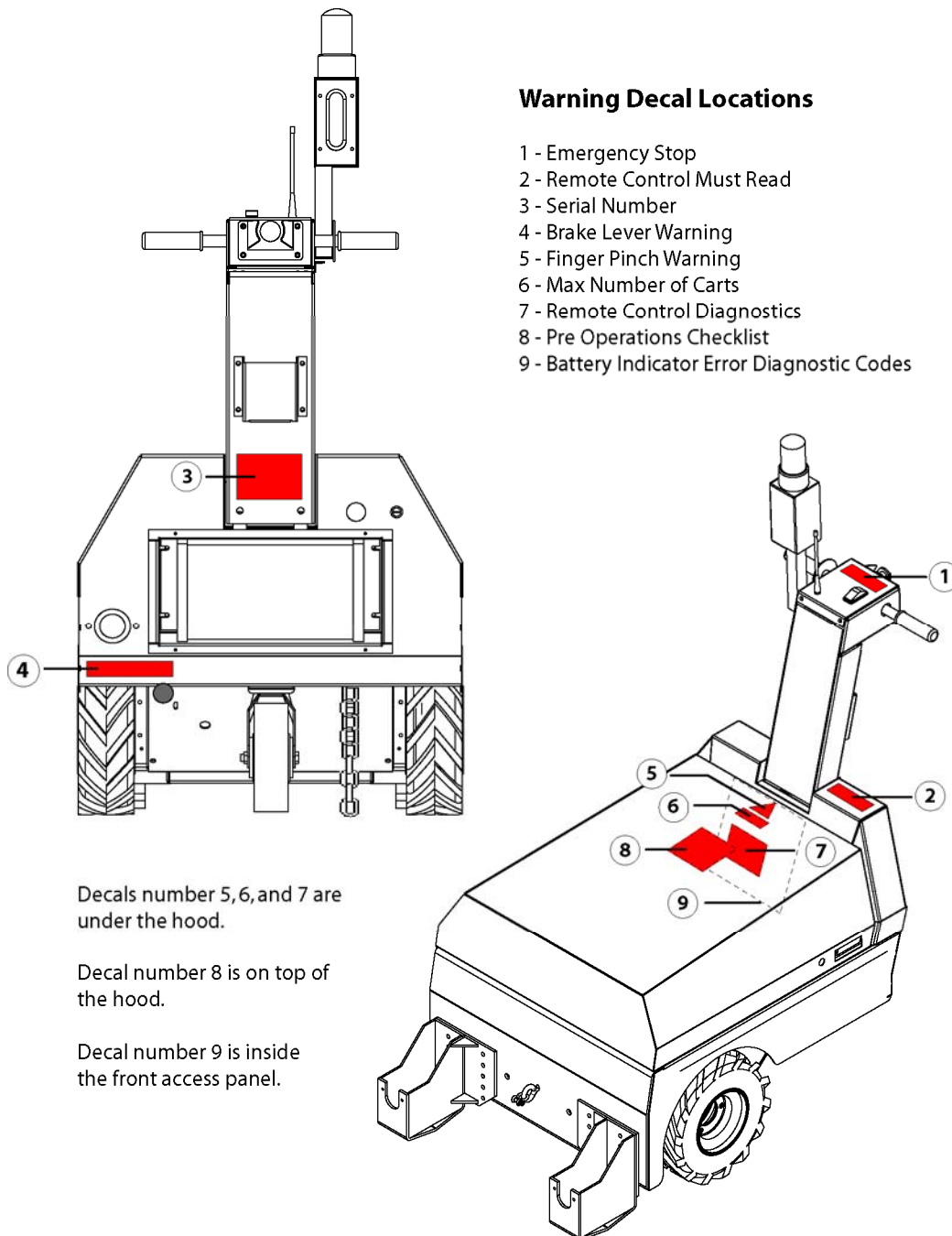

Safety and Warning Labels



#1 – Emergency Stop



#2 – Remote Control Must Read



#3 – Serial Number

Safety and Warning Labels - continued



#4 – Manual Brake Lever Release Warning



**You could pinch your hand
when closing the hood.**

#5 – Finger Pinch Warning



6 – Maximum Cart Number

Safety and Warning Labels - continued

Remote Diagnostic

Receiver model: _____

Serial number: _____

• Problem	↑ Check
Poor reception	<ul style="list-style-type: none"> • Replace battery in transmitter • Check machine has been charged • Check antenna for loose or damaged wires • Check transmitter for physical damage • Make sure operators are pushing max cart limit
No lights on transmitter	<ul style="list-style-type: none"> • Turn CartManager off then on. Press and hold green button on transmitter for 20 seconds • Check buttons for physical damage • Replace button panel
Transmitter doesn't work	<ul style="list-style-type: none"> • Turn CartManager off then on. Press and hold green button on transmitter for 20 seconds • Try a different transmitter
Transmitter works on another CartManager, but not this one	<ul style="list-style-type: none"> • Check you have the correct model • Turn CartManager off then on. Press and hold green button on transmitter for 20 seconds

#7 – Remote Control Diagnostic

CARTMANAGER PRE-OPERATION CHECKLIST:

1. Make sure the charger is in OFF by unplugging the AC power cord from the wall outlet. Wrap the cord securely around the charger cord tabs located under the charger.
2. Make sure the hood is in the down position and that the side hood tabs have secured the hood in place.
3. Make Sure there are no loose or broken parts, including but not limited to: the safety stop switch, light pole handlebars, tires, casters, battery gauge, etc.
4. Insert key into key switch, turn in clockwise motion. You should hear a click.
5. Turn the red safety stop switch button in a clockwise direction and make sure it is popped out and in working condition.
6. Make sure the light is blinking.
7. If light is blinking and battery gauge is in the green or white, the CartManager is ready for operation.
8. Check all obstacles around CartManager. Be careful not to hit or run over anything around the unit. Slowly bring the CartManager outside.
9. Once outside and free of obstacles, perform these pre-retrieving tasks:
 - a. Slowly turn variable speed twist grips in a forward and backward motion and make sure the CartManager responds appropriately with the direction and speed of the handlebars.
 - b. Push safety stop switch IN and make sure that it is working correctly by slowly turning the handlebars backwards, then forwards. If working properly, the CartManager will not move backwards, but will slowly move forwards. Twist the safety stop switch clockwise so the CartManager is in normal, operation mode.

DANGER/WARNING:

The CartManager Shopping Cart Retriever is specifically designed to collect shopping carts in accordance with the Manufacturer's specifications. Without limiting in any way the Manufacturer's Limited Warranty on its Products,
YOU MUST NEVER OPERATE THE CARTMANAGER SHOPPING CART RETRIEVER:

- WITH AN OPERATOR UNDER THE AGE OF 18 YEARS.
- WITH AN OPERATOR NOT PROPERLY AND FULLY TRAINED TO OPERATE THE CARTMANAGER.
- WITH AN OPERATOR SITTING OR RIDING ON THE CARTMANAGER OR RIDING ON OR IN ANY CARTS THE CARTMANAGER MAY BE PUSHING/PULLING.
- WITH ADDED WEIGHT (OR OTHER ADDITIONS, CHANGES OR MODIFICATIONS) NOT SPECIFICALLY PERFORMED BY THE MANUFACTURER OR ITS AUTHORIZED SERVICE REPRESENTATIVES.
- WITH THE HOOD UNLATCHED OR OPEN.
- IN SEVERE WEATHER.
- IF ANY OF THE CARTMANAGER FUNCTIONS AND FEATURES ARE NOT IN GOOD WORKING ORDER.
- FOR ANY PURPOSE OTHER THAN FOR WHICH THE CARTMANAGER WAS DESIGNED.
- WITH AN OPERATOR TAKING ANY MEDICATION KNOWN TO CAUSE IMPAIRMENT OF VISION, REFLEXES OR JUDGMENT.
- IN ANY NEGLIGENT, UNSAFE OR INAPPROPRIATE MANNER, IN OTHER THAN FULL COMPLIANCE WITH APPLICABLE LAWS AND REGULATIONS OR IN ANY MANNER OTHER THAN IN FULL COMPLIANCE WITH THE OWNERS MANUAL AND/OR OPERATING INSTRUCTIONS ACCOMPANYING THE CARTMANAGER.
- NEVER LEAVE THE CARTMANAGER WHEN IT IS IN OPERATION MODE UNATTENDED.
- NEVER EXCEED CART LIMIT POSTED ON YOUR CARTMANAGER.

DISREGARDING ANY OF THESE WARNING MAY CAUSE INJURY, SEVERE DAMAGE OR EVEN DEATH TO YOURSELF, EMPLOYEES, CUSTOMERS, OTHERS, THE BUILDING, OR OTHER PROPERTY, INCLUDING MERCHANDISE, EQUIPMENT, VEHICLES OR THE CARTMANAGER ITSELF. YOU ARE SOLELY RESPONSIBLE FOR ALL CONSEQUENCES ARISING FROM USING THE CARTMANAGER OTHER THAN IN FULL COMPLIANCE WITH THE OWNERS MANUAL AND OPERATING INSTRUCTIONS OR IN DISREGARD OF ANY OF THE ABOVE WARNINGS.

OPERATION / SAFETY GUIDELINES:

IF YOU HAVE A ROPECADDY ON YOUR RETRIEVER:

- a. Pull the rope and hook from the cord reel and make sure it can be easily removed. Pull it out approximately 5 ft and let it go. Make sure it slowly recoils back.
- b. Pull rope lock down in locking position. Make sure it securely locks rope by pulling on the hook with a heavy force. If the rope slips through the lock, SEE STICKER ON ROPE REEL FOR ROPE LOCK TIGHTENING INSTRUCTIONS.

IF YOU HAVE A RADIO/REMOTE CONTROL CARTMANAGER:

- a. Stand clear of the CartManager and push the turtle/slow remote button. CartManager should move slowly forward. Push the rabbit/fast button and CartManager should move forward fast.
- b. Never operate remote unless operator is directly in control of steering the CartManager or chain of carts.

**For service or parts
call: 888.808.9433**



**GATEKEEPER
SYSTEMS**

www.gatekeepersystems.com

#8 – Pre Operations Checklist

CartManager XD+ Owner-Operator Training and Troubleshooting Guide

Page 42

Safety and Warning Labels - continued

Troubleshooting Chart			
LED Code	Programmer LCD Display	Possible Cause	Fault Clearance
01	NO KNOWN FAULTS	n/a	n/a
11	CURRENT SHUNT FAULT	1. Abnormal vehicle operation causing high current spikes. 2. Current sensor out of range. 3. Controller failure.	Cycle key switch. If problem persists, replace controller.
12	HW FAILSAFE	1. Noisy environment. 2. Self-test or watchdog fault. 3. Controller failure.	Cycle key switch. If problem persists, replace controller.
13	M-SHORTED	1. Internal or external short of M- to B-. 2. Incorrect motor wiring. 3. Controller failure.	Check wiring; cycle key switch. If problem persists, replace controller.
14	SRO	1. Improper sequence of key switch, interlock, and direction inputs. 2. Interlock or direction switch circuit open. 3. Sequencing delay too short. 4. Wrong SRO or throttle type selected. 5. Mis-adjusted throttle pot.	Follow proper sequence; adjust throttle if necessary; adjust programmable parameters, if necessary.
21	THROTTLE WIPER HI	1. Throttle input wire open or shorted to B+. 2. Defective throttle pot. 3. Wrong throttle type selected.	When throttle Wiper High Input returns to valid range.
22	EMR REB WIRING	1. Emergency reverse wire or check wire open.	Re-apply emergency reverse or cycle interlock.
23	HPD	1. Improper sequence of key switch, interlock, and throttle inputs. 2. Mis-adjusted throttle pot. 3. Sequencing delay too short. 4. Wrong HPD or throttle type selected. 5. Mis-adjusted throttle pot.	Follow proper sequence; adjust throttle if necessary; adjust programmable parameters, if necessary.
	SVRC TOTAL	1. Total maintenance timer expired.	Reset with Programmer.
	SVRC TRAC	1. Traction maintenance timer expired.	Reset with Programmer.
	TOTAL DISABLED	1. Total disabled timer expired.	Reset with Programmer.
	TRAC DISABLED	1. Traction disabled timer expired.	Reset with Programmer.
24	THROTTLE WIPER LO	1. Throttle pot wire open or shorted to B+. 2. Wrong throttle type selected. 3. Defective throttle pot.	When Throttle Wiper Low Input returns to valid range.
31	FIELD SHORT	1. Main contactor coil shorted. 2. Field winding shorted to B+ or B-. 3. Field resistance too low.	Check contactor coil and field winding; cycle key switch.
32	MAIN CONT WELDED	1. Main contactor stuck closed. 2. Main contactor driver shorted.	Check wiring and contactor; cycle key switch.
33	FIELD OPEN	1. Field winding connection open. 2. Field winding open.	Check wiring and cycle key switch.
34	MISSING CONTACTOR	1. Main contactor coil open. 2. Main contactor missing. 3. Wire to main contactor open.	Check wiring and cycle key switch.
41	LOW BATTERY VOLTAGE	1. Battery voltage < undervoltage cutback. 2. Corroded battery terminal. 3. Loose battery or controller terminal.	When voltage rises above undervoltage cutoff point.
42	OVERVOLTAGE	1. Battery voltage > overvoltage shutdown limit. 2. Vehicle operating with charger attached.	When voltage falls below overvoltage cutoff point.
43	THERMAL CUTBACK	1. Temperature > 85° C, or < -25° C. 2. Excessive load on vehicle. 3. Improper mounting of controller.	Clears when heat sink temperature returns to within acceptable range.
44	ANTI-TIEDOWN	1. Mode switches shorted to B+. 2. Mode Select 1 "tied down" to Select Mode 2 or Mode 4 permanently.	Release Mode Select 1.
	MOTOR HOT	1. Field resistance > motor hot setpoint.	When resistance < setpoint.
	MOTOR WARM	1. Field resistance > motor warm setpoint.	When resistance < setpoint.

9 – Battery Indicator Error Codes

Ordering Parts

When ordering parts, you will need the following information:

- Model of the unit
- Serial number
- Part number
- Part description

Item No.	Part Number	Part Description
1.	A500128-03	Swivel wheel caster 8"
2.	E500238-01	Strobe light assembly
3.	E500238-02	Strobe light bulb
4.	F14753-507	Strobe light pole
5.	M500276-01	Spring plunger, strobe light pole
6.	E500124-03	Brake light (LED)
7.	E500187	Emergency stop switch - red button
8.	E500146-01	Circuit breaker 20A
9.	E500519-05	Battery charger, 230V
10.	E500145-01	Key switch 2 position
11.	A500145-02	Extra keys (set of 2)
12.	E500155-03	Battery, maintenance free, deepcycle, Group 27
13.	E500125-04	Battery discharge indicator and fault indicator
14.	E500126-210	Motor controller
15.	E500275-300	Motor SEPEX, 36 Volt DC
16.	M3088	Brake, motor with limit switch
17.	E-500402-01	Horn
18.	D5060	Speed board
19.	E500356-041	Remote radio set (transmitter and receiver), 9100 / 418 MHz, North America & UK
20.	E500356-042	Remote radio set (transmitter and receiver), 9100 / 433 MHz North America & EU
21.	E500356-052	Remote transmitter, 9100 / 418 MHz, North America & UK
22.	E500356-053	Remote transmitter, 9100 / 433 MHz, North America & EU
23.	E500295-04	Antenna assembly kit
24.	E500295-041	Antenna replacement

Item No.	Part Number	Part Description
25.	A500129	Wheel assembly, foam filled
26.	A500273	Aggressive tread tire
27.	A500150-03	Shag Strap

Warranty Information

Limited Warranty

IMPORTANT: Read this entire Limited Warranty before using the CartManager™ product. The CartManager™ product (or other Gatekeeper Systems, Inc. product-collectively referred to herein as the “Product”) manufactured by Gatekeeper Systems, Inc, a Delaware corporation (“Manufacturer”) is believed to be reliable if the directions for its use, maintenance and operating procedures are followed carefully. However, it is impossible to eliminate all risks inherently associated with the use of this Product. Risk of failure, including personal injury, dismemberment, injury to property or even death, may result from misuse, abuse, neglect, negligent use, accidental or intentional damage, ordinary wear and tear, violation or omission of standard operating procedures, improper maintenance, failure to perform routine and preventive maintenance, alterations, additions and/or modifications to the Product, use by any individual not a fully trained and fully authorized operator, and improper training of the operator, all of which are beyond the control of Manufacturer. All such risks are fully assumed by the purchaser/customer of the Product (“Customer”).

Manufacturer offers a limited warranty (the “Limited Warranty”) to each customer who is the original purchaser of this Product that, effective for a period one year (“Limited Warranty Period”) from the date of delivery of the Product to the Customer, that the Product is free from defects in material or workmanship in normal use and service. Should any Product prove not to conform to the foregoing Limited Warranty, the remedies of Customer for any breach of the foregoing Limited Warranty shall be limited to the repair or replacement of the Product **IN NO EVENT SHALL MANUFACTURER’S OBLIGATIONS PURSUANT TO THIS LIMITED WARRANTY EXCEED THE PURCHASE PRICE PAID TO THE MANUFACTURER BY THE CUSTOMER FOR THE PARTICULAR PRODUCT INVOLVED, TO THE EXCLUSION OF ALL OTHER REMEDIES OR LIMITATIONS, INCIDENTAL OR CONSEQUENTIAL DAMAGES.** The Limited Warranty, which is Customer’s **EXCLUSIVE REMEDY**, shall be **FURTHER LIMITED** as follows:

1. If the defect in material or workmanship is disclosed to the Manufacturer by the Customer within the first ninety (90) days following delivery of the Product to the Customer, the Limited Warranty shall be the full cost of the labor and parts to repair or replace the defective Product or component parts thereof.
2. If the defect in material or workmanship is disclosed to the Manufacturer by the Customer prior to the expiration of the Limited Warranty Period but more than ninety (90) days following delivery of the Product, the Limited Warranty shall be the Manufacturer’s cost of the replacement parts (excluding repair labor) required to repair the defective Product or component part.

Any warranty repair or replacement of Products or defective component parts shall occur at the Manufacturer’s (or authorized service provider’s) place of business. In order to obtain warranty service, the Customer must return the defective Product to the Manufacturer within the Warranty Period, together with proof of purchase by Customer establishing date of delivery, with freight charges and applicable costs of repair, if any, prepaid, which Product the Manufacturer shall have determined to its satisfaction, after examination, to have been defective. The Manufacturer shall ship, prepaid; any repaired or replaced Product covered by the Limited Warranty, to the Customer’s facility located within the continental United States.

(continued on next page)

Limited Warranty Program (continued)

The Limited Warranty is invalid if the factory-applied number has been altered or removed from the Product. The Limited Warranty does not cover cosmetic damage or damage due to acts of God, accident, misuse, abuse, neglect, negligent use, accidental or intentional damage, ordinary wear and tear, violation or omission of standard operating procedures improper maintenance, failure to perform routine and preventative maintenance, alternations, additions and/or modifications to the Product, use by any individual not a fully trained and fully authorized operator, and improper training of the operator, or repair or attempted repair by anyone other than Manufacturer or its authorized agents, nor to any Product which is leased or used as rental equipment. The occurrence of any of the foregoing voids the Limited Warranty. This Limited Warranty does not cover Customer instruction or training.

THIS LIMITED WARRANTY PROGRAM IS EXCLUSIVE AND IS GIVEN AND ACCEPTED IN LIEU OF ANY AND ALL OTHER WARRANTIES, WHETHER WRITTEN OR ORAL, EXPRESSED OR IMPLIED OR INFERABLE FROM THE COURSE OF DEALING OR USAGE OF TRADE, INCLUDING, WITHOUT LIMITATION, THE IMPLIED WARRANTY OR MERCHANTABILITY AND THE IMPLIED WARRANTY OF FITNESS FOR A PARTICULAR PURPOSE AND ANY IMPLIED WARRANTY ARISING FROM PERFORMANCE, COURSE OF DEALING OR USAGE OF TRADE, AND ALL OTHER OBLIGATIONS, LIABILITIES, RIGHTS, CLAIMS OR REMEDIES, INCLUDING ANY RIGHT IN CONTRACT, TORT, STRICT LIABILITY OR ANY RIGHT ARISING FROM MANUFACTURER'S NEGLIGENCE, ACTUAL OR IMPUTED FOR CLARIFICATION ONLY (AND NOT IN ANY WAY TO EXPAND THE FOREGOING EXCLUSIVE REMEDIES):

1. Under no circumstances will manufacturer be liable for lost profits or any other incidental, on sequential, special or indirect damages resulting from the purchase or use of this product, including, without limitation, economic loss, cost of capital, claims of customers for failure of supply or loss of use or damage to persons or to other property, notwithstanding the fact that the manufacturer has been advised of the possibility of such damages.
2. The total liability of the manufacturer to customer shall not exceed the total purchase price paid by the distributor or manufacturer for the particular product involved.
3. No agreement varying or extending the foregoing warranties, remedies or limitations will be binding upon the manufacturer unless in writing and signed by a duly authorized corporate officer of the manufacturer.

If any term or condition of this Limited Warranty program is in violation of applicable local, state, or federal law, this having jurisdiction in the matter, shall rewrite and reform the Limited Warranty to the minimum extent required so as to be permitted under applicable law.

Contacting Gatekeeper Systems

For more information about CartManager training and troubleshooting, or to order replacement parts or report an issue, contact the Gatekeeper Systems Inc. regional Customer Support office nearest to your location.

USA

Gatekeeper Systems, Inc.
2520 N. Great Southwest Parkway
Suite 110
Grand Prairie, TX 75050
(888) 808-9433

Canada

Gatekeeper Systems Canada, Ltd.
272 Galaxy Boulevard
Etobicoke, Ontario
Canada M9W 5R8
(416)-798-8719

All Other Areas

Gatekeeper Systems SAS
58 rue de Neuilly
Parc des Guillaumes
93130 Noisy Le Sec, France
+33 148 54 76 78