

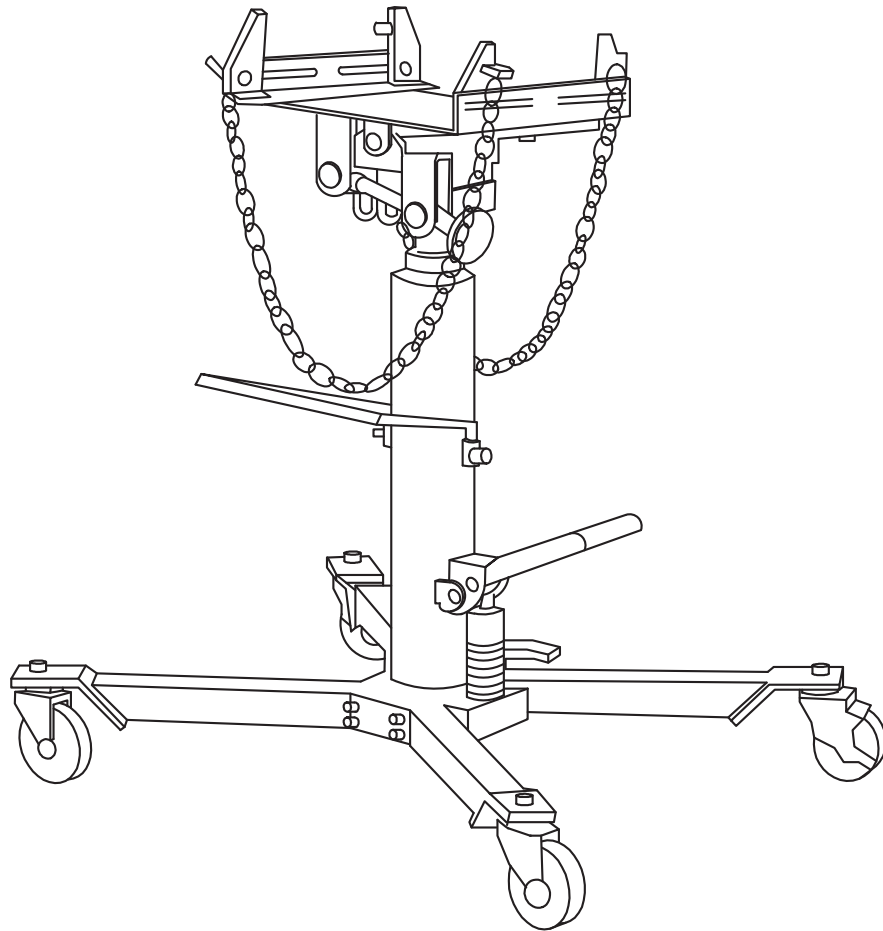

MODEL 766B
TRANSMISSION JACK
1/2 TON CAPACITY
USER'S MANUAL



Jackco Transnational Inc. © 2012
South El Monte, CA
888-452-2526 www.jackco.com

FOR YOUR SAFETY

Read all instructions, warnings and cautions carefully. Follow all safety precautions to avoid personal injury or property damage during system operation. Jackco cannot be responsible for damage or injury resulting from unsafe product use, lack of maintenance or incorrect product and/or system operation. Contact Jackco when in doubt as to the safety precautions and operations.

Failure to comply with the following cautions and warnings could cause equipment damage and personal injury.

WARNING

- Stay clear of loads supported by hydraulics. A cylinder, when used as a load lifting device, should never be used as a load holding device. After the load had been raised or lowered, it must always be blocked mechanically.
- Do not exceed equipment rating never attempt to lift a load weighing more than the capacity of the cylinder. Overloading causes equipment failure and possible personal injury. The cylinders are designed for a maximum pressure of 10,000 psi. Do not connect a jack or cylinder to a pump with a higher pressure rating.
- The system operating pressure must not exceed the pressure rating of the lowest rated component in the system. Install pressure gauges in the system to monitor operating pressure. It is your window to what is happening in the system.
- **BE SURE SETUP IS STABLE BEFORE LIFTING LOAD.**
Cylinders should be placed on a flat surface that can support the load. Where applicable, use a cylinder base for added stability. Do not weld or otherwise modify the cylinder to attach a base or other support.
- Avoid situations where loads are not directly centered on the cylinder plunger. Off-center loads produce considerable strain on cylinders and plungers. In addition, the load may slip or fall, causing potentially dangerous results.
- Immediately replace worn or damaged parts genuine JACKCO parts. Standard grade parts will break causing personal injury and property damage. JACKCO parts are designed to fit properly and withstand high loads.

DANGER

- To avoid personal injury keep hands and feet away from cylinder and work piece during operation.
- **NEVER** set the relief valve to a higher pressure than the maximum rated pressure of the pump. Higher settings may result in equipment damage and/or personal injury. Do not remove relief valve.

CAUTION

- Keep hydraulic equipment away from flames and heat. Excessive heat will soften packing and seals, resulting in fluid leaks. Heat also weakens hose materials and packings. For optimum performance do not expose equipment to temperatures of 150°F or higher. Protect hoses and cylinders from weld spatter.
- Hydraulic equipment must only be serviced by a qualified hydraulic technician. For repair service, contact your equipment dealer / service center. To protect your warranty, use only JACKCO hydraulic oil.

Specifications

Capacity	Base Size(L x W)	Min Height	Max Height	Net Weight
1/2 Ton	37" x 31"	38"	74 1/2"	154 Lbs

Assembly

- Assemble the swivel casters on the jack legs using lock washers and nuts provided.
- Assemble the legs (with the casters) to the jack's base, and slightly secure with the Allen socket bolts and lock washers provided.
- Position the jack (with legs) on a hard level surface. Tighten the Allen socket bolts while all four casters are contacting the floor and the jack appears vertical to the floor.
- Locate the draw bar and the two hex bolts in the carton, Insert the draw bar into its sockets on the cylinder, and secure with the hex bolts provided.
- Saddle assembly: Loosen the bolt from outside the saddle adapter. Mount the saddle adapter onto the top of the piston rod. Once mounted, tighten the bolt and secure entire saddle assembly.
- Use the tilt adjusting knob to adjust the saddle angle to a relatively horizontal position.
- Attach the two corner support brackets onto the universal saddle, and fasten with the hex bolts and nuts.
- Locate the fixing bracket in the chain pack. Assemble the fixing bracket on the corner support bracket and secure with the hook and screw caps. Assemble chains and chain hardware to the corner support bracket.
- The chains and chain hardware are provided to secure the transmission, transfer box, or differential to the saddle assembly by the different shape of their housing. When using, both ends of the chain should be anchored to the bracket.

Setup

- To prevent oil leak during shipment, a shipping plug is used to ensure the best sealing function. Remove the shipping oil plug, and replace it with vented oil plug provided.
- The reservoir tube is shipped filled with hydraulic oil. Before using the jack for the first time, press the release pedal to open the release valve, and operate the foot pump 8-10 full strokes to distribute the oil.

Operation

- Follow the vehicle's recommended service procedure for removal of the component.
- Position the jack under the vehicle.
- Raise the jack by operating the foot pump until the saddle reaches the component.
- Adjust the support brackets to fit the component.
- Use the tilt crank to align the saddle with the component.
- Finish raising the jack to the component. Secure the chain assembly around the component.

Bleed Air from the Hydraulic System

Air can accumulate within a hydraulic system during shipment or after prolonged use. This entrapped air causes the jack to respond slowly or feel "spongy". Follow the steps below to bleed the system :

To bleed the air in the oil system:

1. Pump the jack to the highest point where the first and the second stages are both at the maximum height.
2. Get the help of another person to keep the release pedal depressed, and activate the foot pedal about 15-20 times.
3. Let go of the release pedal; the air in the oil system should be bled successfully.

To bleed the air in the second cylinder:

1. Locate the air bleeder screw at the top nut, which is on the top of the first piston rod.
2. Pump the jack to its maximum height. Use an Allen socket wrench to loosen the air bleeder screw for no more than two full rotations. Push the saddle assembly downward to purge the air in the cylinder out until nothing but oil drains out of the bleeding hole.
3. Tighten the bleeder screw and double check. It may be necessary to repeat the above steps several times.

Model: 766B Parts List

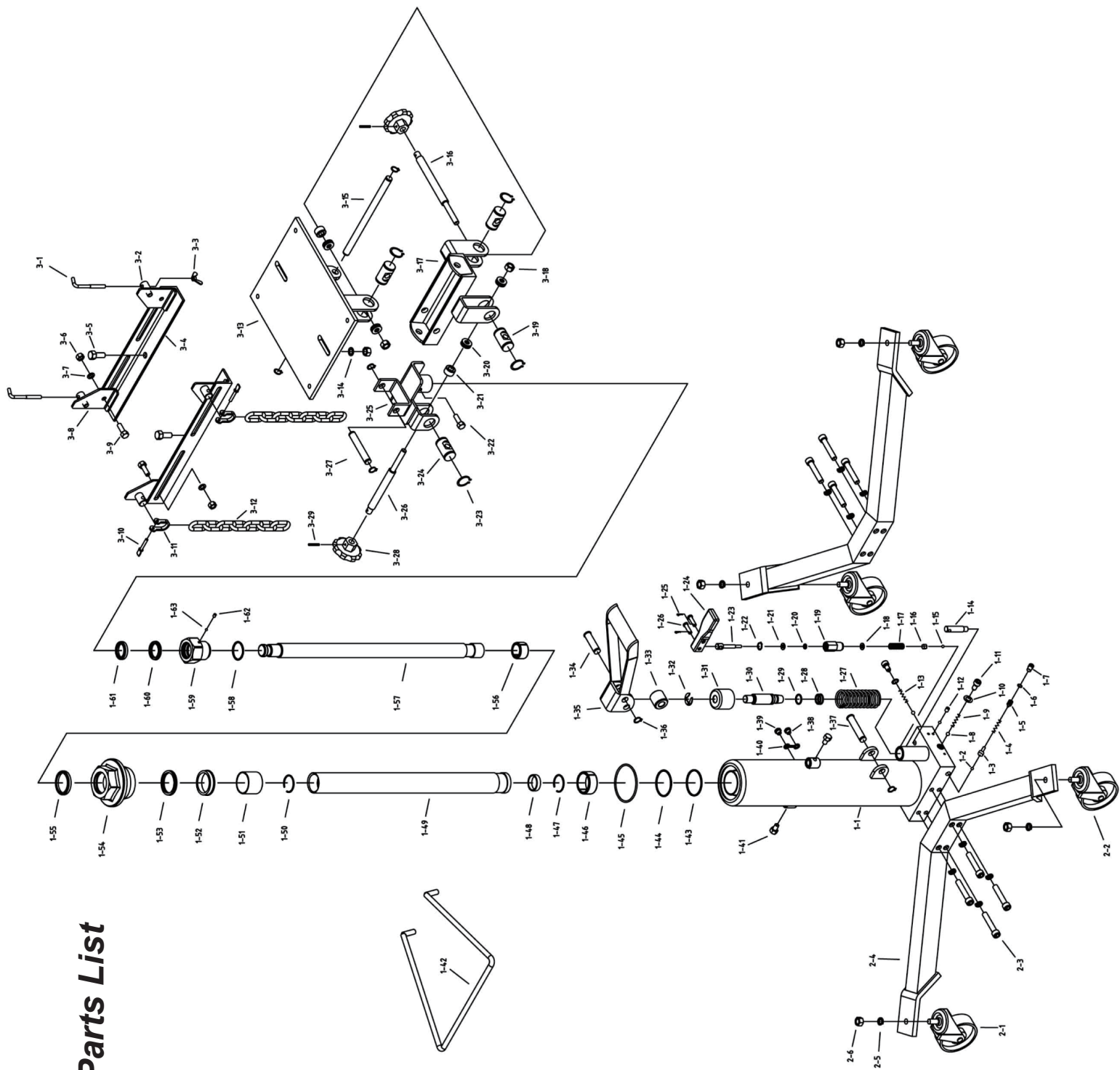

Part No.	Description	Q'ty	Part No.	Description	Q'ty	Part No.	Description	Q'ty	Part No.	Description	Q'ty
1-1	Oil Cylinder Ass'y	1	1-28	Y-seal	1	1-55	Dustproof	1	3-13	Universal Saddle	1
1-2	Steel Ball	1	1-29	O-ring	1	1-56	Bushing	1	3-14	Flat Washer	2
1-3	Ball Seat	1	1-30	Pump Plunger	1	1-57	Piston Rod	1	3-15	Shaft	1
1-4	Spring	1	1-31	Spring Cover	1	1-58	O-ring	1	3-16	Screw	1
1-5	Screw	1	1-32	Snap Ring	1	1-59	Screw Cap	1	3-17	Bracket	1
1-6	O-ring	1	1-33	Bushing	1	1-60	Y-seal	1	3-18	Locknut	2
1-7	Bolt	1	1-34	Pin	1	1-61	Dustproof	1	3-19	Shaft	2
1-8	Steel Ball	2	1-35	Foot Pedal	1	1-62	Steel Ball	1	3-20	Bearing	4
1-9	Spring	1	1-36	Snap Ring	6	1-63	Air Bleed Screw	1	3-21	Bushing	2
1-10	Copper Washer	2	1-37	Pin	1	2-1	Swivel Caster A	2	3-22	Bolt	1
1-11	Bolt	2	1-38	Screw	1	2-2	Swivel Caster B	2	3-23	Snap Ring	8
1-12	Screw	4	1-39	Screw	1	2-3	Bolt	8	3-24	Shaft	2
1-13	Spring	1	1-40	Sealing Gasket	1	2-4	Leg	2	3-25	Bracket	1
1-14	Rod	1	1-41	Bolt	2	2-5	Lock Washer	12	3-26	Screw	1
1-15	Steel Ball	5	1-42	Draw Bar	1	2-6	Nut	6	3-27	Shaft	1
1-16	Ball Seat	1	1-43	Nylon Washer	1	3-1	Hook	2	3-28	Knob	2
1-17	Spring	1	1-44	O-ring	1	3-2	Fixing Bracket A	2	3-29	Pin	2
1-18	Copper Washer	1	1-45	O-ring	1	3-3	Screw Cap	2	--		
1-19	Oil Release Valve	1	1-46	Bushing	1	3-4	Corner Bracket	2	--		
1-20	O-ring	1	1-47	Snap Ring	1	3-5	Bolt	2	--		
1-21	Washer	1	1-48	Bushing	1	3-6	Nut	4	--		
1-22	Snap Ring	1	1-49	Inner Cylinder	1	3-7	Flat Washer	4	--		
1-23	Oil Release Rod	1	1-50	Snap Ring	1	3-8	Fixing Bracket B	2	--		
1-24	Oil Release Pedal	1	1-51	Bushing	1	3-9	Bolt	4	--		
1-25	Pin	2	1-52	Bushing	1	3-10	Screw	2	--		
1-26	Pin	2	1-53	Y-seal	1	3-11	Link	2	--		
1-27	Spring	1	1-54	Screw Cap	1	3-12	Safety Chain	2	--		

Maintenance

Regularly lubricate all moving parts of the jack. Pay special attention to the lift screw and related linkages.

- A medium weight lubricating grease should be used on all external moving parts, such as bearing surface, pivot points tilt screws, etc.
- Regularly check the oil level. With the saddle fully lowered, remove the oil filler screw, and check the oil level. Oil should be at the bottom of the filler screw holes. Fill if necessary.
- Use only hydraulic jack oil. Do not use hydraulic brake fluid.
- If the jack fails to operate, check the oil level and/or bleed until before seeking service.
- Do not use this jack as a wash rack when washing or steam cleaning transmissions.

Trouble Shooting

Problem	Cause	Solution
Jack will not lift load	<ul style="list-style-type: none"> • Overload condition • Air supply inadequate 	<ul style="list-style-type: none"> • Remedy overload condition • Ensure adequate air supply
Jack bleeds off after lift	Overload condition	Remedy overload condition
Jack will not lower after unloading	<ul style="list-style-type: none"> • Reservoir overfilled • Linkages Binding 	<ul style="list-style-type: none"> • Drain fluid to proper level • Clean and lubricate moving parts
Poor lift performance	<ul style="list-style-type: none"> • Fluid level low • Air trapped in system 	<ul style="list-style-type: none"> • Ensure proper fluid level • With ram fully retracted, remove oil filler screw / vent screw to let pressurized air escape, then reinstall oil filler screw/ vent screw
Will not lift to full extension	Fluid level low	Ensure proper fluid level

LIMITED ONE YEAR WARRANTY

Jackco Transnational Inc. warrants all Jackco equipment and tools to the original purchaser against any manufacturing defect in material or workmanship for a period of one (1) year from the original date of purchase. If the defective equipment or tool is determined to be covered under this warranty, it shall be repaired or replaced at manufacturer's discretion without charge, provided that the equipment or tool must be returned with proof of purchase to the dealer and freight prepaid, if returned to the manufacturer. This warranty shall not apply to damage due to accident, negligent use, and lack of maintenance, abuse or applications other than the specific function the equipment or tool is designed for.

No other warranties, expressed or implied, including those of merchantability or fitness for particular purpose shall be applicable to Jackco except as specifically stated herein. In no event shall Jackco be liable to any party for any special, direct, indirect, consequential, punitive damage of any nature caused by the sale or use of the equipment or tool.

Note: This warranty gives the original purchaser specific legal rights which may vary from state to state.

Jackco Transnational Inc. © 2012
 South El Monte, CA
 888-452-2526 www.jackco.com