



EP810 Series
Pentium[®] M All-in-One
EPIC Board
with DualView display

User's Manual

Disclaimers

This manual has been carefully checked and believed to contain accurate information. AXIOMTEK Co., Ltd. assumes no responsibility for any infringements of patents or any third party's rights, and any liability arising from such use.

AXIOMTEK does not warrant or assume any legal liability or responsibility for the accuracy, completeness or usefulness of any information in this document. AXIOMTEK does not make any commitment to update the information in this manual.

AXIOMTEK reserves the right to change or revise this document and/or product at any time without notice.

No part of this document may be reproduced, stored in a retrieval system, or transmitted, in any form or by any means, electronic, mechanical, photocopying, recording, or otherwise, without the prior written permission of AXIOMTEK Co., Ltd.

CAUTION

If you replace wrong batteries, it causes the danger of explosion. It is recommended by the manufacturer that you follow the manufacturer's instructions to only replace the same or equivalent type of battery, and dispose of used ones.

**©Copyright 2007 by AXIOMTEK CO., LTD
All Rights Reserved
December 2007, Version A4
Printed in Taiwan**

ESD Precautions

Computer boards have integrated circuits sensitive to static electricity. To prevent chipsets from electrostatic discharge damage, please take care of the following jobs with precautions:

- Do not remove boards or integrated circuits from their anti-static packaging until you are ready to install them.
- Before holding the board or integrated circuit, touch an unpainted portion of the system unit chassis for a few seconds. It discharges static electricity from your body.
- Wear a wrist-grounding strap, available from most electronic component stores, when handling boards and components.

Trademarks Acknowledgments

AXIOMTEK is a trademark of AXIOMTEK Co., Ltd.

MS-DOS and Windows '95 are trademarks of Microsoft Corporation.

AWARD is a trademark of Award Software. Inc.

IBM, PC/AT, PS/2, VGA are trademarks of International Business Machines Corporation.

Intel[®] and Pentium[®] are trademarks of Intel Corporation.

Winbond is a trademark of Winbond Electronics Corp.

SMI is a trademark of Silicon Motion Inc.

Other brand names and trademarks are the properties and registered brands of their respective owners.

Table of Contents

Disclaimers	ii
ESD Precautions	iii
Chapter 1 Introduction	1
1.1 Specifications	2
1.2 Utilities Supported	5
Chapter 2 Jumpers and Connectors	6
2.1 Board Dimensions	6
2.2 Board Layout and Fixing Holes	8
2.3 Jumper Settings	10
2.3.1 CMOS Clear Jumper (JP1)	11
2.3.2 CompactFlash Power (JP2)	11
2.3.3 Power Supply Selection (JP3)	12
2.3.4 COM1 Mode Select for Type (JP7, JP4, JP5)	12
2.3.5 COM1~COM2 Mode (JP6, JP8)	13
2.3.6 Audio Output Select Jumper (JP9)	15
2.3.7 Power Selection of Flat Panel 1'ST Connector (JP10)	15
2.3.8 Power Selection of Flat Panel 2'ND Connector (JP11)	16
2.4 Connectors	17
2.4.1 Power Input Connector (CN1)	18
2.4.2 USB1~4 Connectors (CN2, CN17)	18
2.4.3 DIO Connector (CN3)	19
2.4.4 Enhanced IDE Interface Connector (CN5)	20
2.4.5 FDD Connector (CN6)	20
2.4.6 VGA/LCD Connectors (CN20, CN7, CN8, CN9, CN10)	21
2.4.7 Flat Panel Bezel Connector (CN11)	23
2.4.8 Audio Connector (CN12)	24
2.4.9 Serial Port Interface (CN13, CN18)	25
2.4.10 Parallel Port (CN14)	26
2.4.11 Ethernet RJ-45 Connectors (CN15, CN16)	27
2.4.12 Keyboard and PS/2 Mouse Connector (CN19)	29
2.4.13 CompactFlash Connector (CN21)	29
2.4.14 CPU Fan Connector (FAN1)	30
Chapter 3 Hardware Description	32
3.1 Microprocessors	32
3.2 BIOS	32
3.3 System Memory	32
3.4 I/O Port Address Map	33
3.5 Interrupt Controller	34
Chapter 4 Award BIOS Utility	36
4.1 Entering Setup	36
4.2 Control Keys	37

4.3	Getting Help	37
4.4	The Main Menu	38
4.5	Standard CMOS Setup Menu.....	39
4.6	Advanced BIOS Features.....	42
4.7	Advanced Chipset Features	47
4.8	Integrated Peripherals	50
4.9	Power Management Setup.....	56
4.10	PnP/PCI Configuration Setup.....	61
4.11	PC Health Status.....	63
4.12	Frequency/Voltage Control.....	64
4.13	Load Fail-Safe Defaults.....	65
4.14	Load Optimized Defaults	66
4.15	Set Supervisor/User Password	67
4.16	Save & Exit Setup	68
4.17	Exit Without Saving	69

Appendix Watchdog Timer 70

MEMO

Chapter 1

Introduction



The **EP810** is an Intel® Pentium® M/Celeron™ M CPU equipped EPIC board with graphics, Fast Ethernet and audio interface. With the designing of space-limited application, the **EP810** is practically the finest embedded Pentium® M board that exists in the market. The **EP810 Series** can be adapted for Intel® low power consumption Pentium® M microprocessors. To simplify system integration, it provides users with super I/Os, UXGA, LCD, Ethernet, solid state disk that makes all on a single board. There comes with unique embedded features that 2 serial ports (1 x RS-232, 1 x RS-232/422/485) with +5V/12V power capability allow the adoption of an extensive array of PC peripherals. The industrial-grade construction of **EP810 series** allows your system to endure the continuous operation in hostile environments where require most stability and reliability. The system dependability of **EP810 series** is highly enhanced by a special industrial feature of the built-in Watchdog Timer, which makes the board outstanding among others.

Designed for the professional embedded developers, the Pentium® M embedded board **EP810 Series** is virtually the ultimate one-step solution for embedded system applications.

1.1 Specifications

- **CPU**
 - BGA & Socket 479 compliant -- Pentium® M and Celeron™ M
- **System Chipset**
 - Intel® 852GM + ICH*4
- **Bus Clock**
 - 400MHz
- **BIOS**
 - Phoenix-Award BIOS, Y2K compliant
 - 4Mbit Flash, DMI, Plug and Play
 - SmartView for multiple LCD type selection, display mode option and application extension features
 - RPL/PXE Ethernet Boot ROM
 - "Load Optimized Default" to backup customized Setting in the BIOS flash chip to prevent from CMOS battery fail
- **System Memory**
 - One DDR266 SODIMM
 - Maximum DDR of up to 1GB DDR266
- **L2 Cache**
 - Integrated in CPU
- **Onboard IDE**
 - One parallel ATA-100
 - PATA-100 as PIO Mode 0-4, DMA Mode 0-2 and Ultra DMA/33/66/100
- **CompactFlash Socket**
 - One CompactFlash Type II Socket
- **Onboard Multi I/O**
 - One floppy port

- One RS-232
- One RS-232/422/485
- **USB Interface**
 - Four USB ports with fuse protection and complies with USB Spec. Rev. 2.0
- **Real Time Clock**
 - Integrated Intel® ICH*4
- **Watchdog Timer**
 - 1~255 seconds; up to 255 levels
- **Graphics/Streaming**
 - Integrate Intel® 852GM GMCH
 - Unified Memory Architecture shares system memory up to 32MB
 - Single display mode maximum resolutions:
 - ◆ CRT: 2048 x 1536@ 75Hz
 - ◆ LVDS LCD: 1600 x 1200
 - DualView display mode
 - ◆ CRT: 2048 x 1536@ 75Hz
 - ◆ LVDS LCD: 1600 x 1200
 - LCD backlight control supported
- **Ethernet**
 - One Realtek 8100C PCI Bus 10/100M Base-T
 - One Realtek 8100BL PCI Bus 10/100M Base-T
 - Wake On LAN (via ATX power supply)
 - Equipped with RJ-45 interface
- **Audio**
 - Realtek ALC202A AC'97 codec audio
 - Amplify for speaker-out with 2.5W for each channel
 - MIC-in, Line-in, Line-out/Speaker-out (jumper selectable)
- **Power Management -- ACPI (Advanced Configuration and**

Power Interface)

- **Form Factor** EPIC form Factor
- **Dimensions** 115 x 165 mm²



NOTE *All specifications and images are subject to change without notice.*

1.2 Utilities Supported

- Chipset Driver
- Ethernet Driver
- VGA Drivers
- Audio Drivers

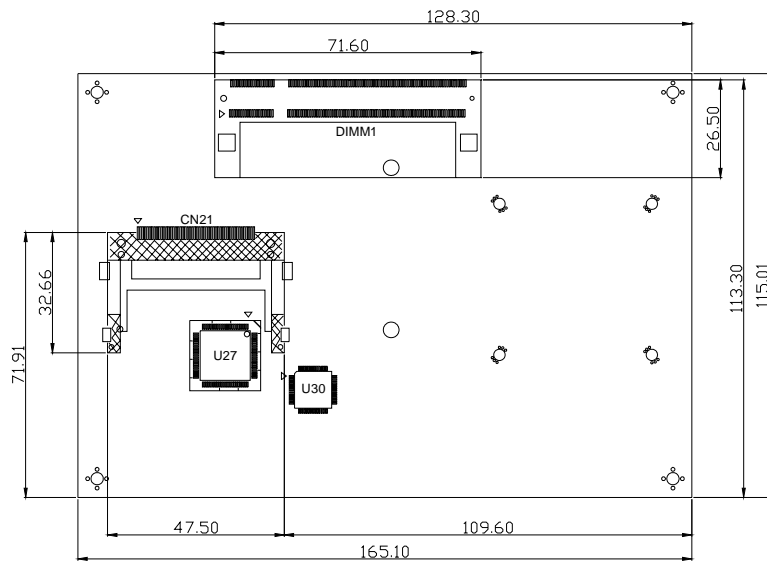

Solder Side

2.2 Board Layout and Fixing Holes

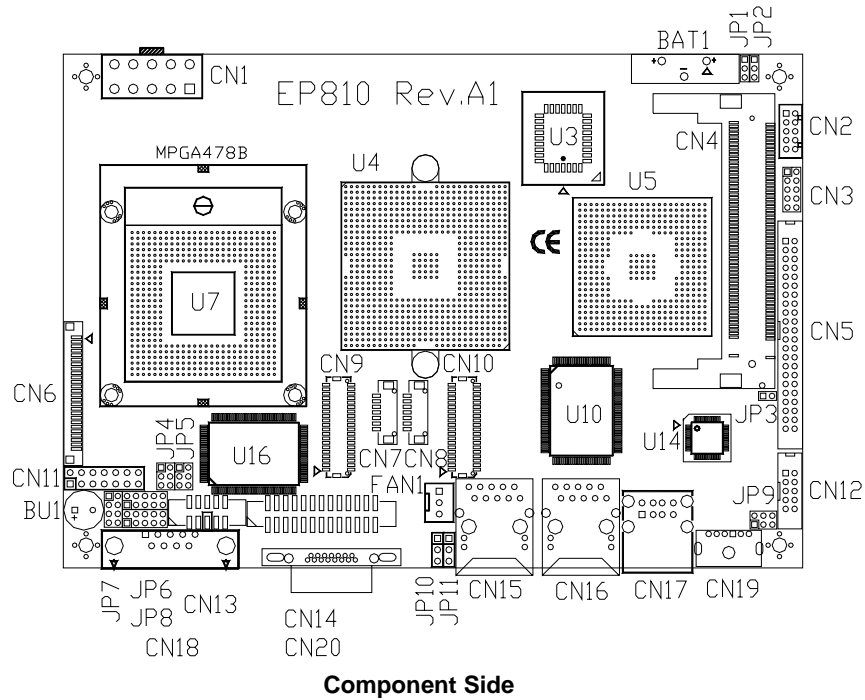

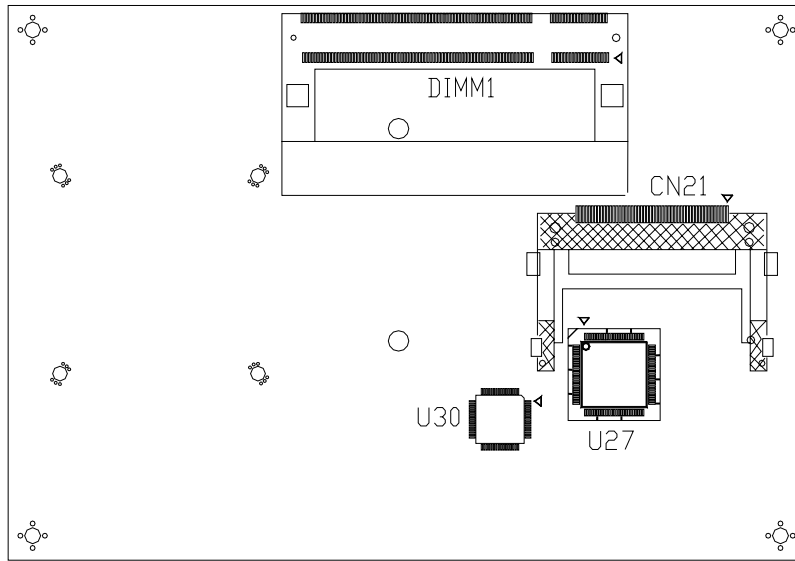

Solder Side



2.3 Jumper Settings

The **EP810 Series** is configured to match the needs of your application with the proper jumper settings. The table below is a summary of all the jumpers and their corresponding functions onboard the **EP810 Series**. The succeeding tables show the correct jumper settings for the onboard devices.

Jumper	Default Setting		Jumper Setting
JP1	Clear CMOS Setting: Normal		Short 1-2
JP2	Compact Flash Voltage Selection Default: 5V		Short 2-3
JP3	Power Supply Selection: AT power supply		Open
JP4	COM1 Mode Select: RS-232		Short 3-5, 4-6
JP5	COM1 Mode Select: RS-232		Short 3-5, 4-6
JP6	COM1 Mode Select	CN18 Pin 1: DCD	Short 7-9
		CN18 Pin 9: RI	Short 8-10
JP7	COM1 Mode Select: RS-232		Short 1-2
JP8	COM2 Mode Select	CN13 Pin 1: DCD	Short 7-9
		CN13 Pin 8: RI	Short 8-10
JP9	Audio Line Out/Speaker Out: Line Out		Short 1-3, 2-4
JP10	Flat Panel 1 Power Selection: Default: 3.3V		Short 1-2
JP11	Flat Panel 2 Power Selection: Default: 3.3V		Short 1-2



2.3.1 CMOS Clear Jumper (JP1)

You may need to use this jumper is to clear the CMOS memory if incorrect settings in the Setup Utility.



Description	Function	Jumper Setting
CMOS Clear	Normal (Default)	
	Clear CMOS	

2.3.2 CompactFlash Power (JP2)

This jumper is to select the power for CompactFlash interface.

Description	Function	Jumper Setting
CompactFlash Voltage Selection	3.3V	
	5V (Default)	

2.3.3 Power Supply Selection (JP3)

Description	Function	Jumper Setting
Power Supply Selection	AT POWER (Default)	
	ATX POWER	

2.3.4 COM1 Mode Select for Type (JP7, JP4, JP5)

These jumpers select the COM1 port's communication mode to operate RS-232 or RS-422/485.

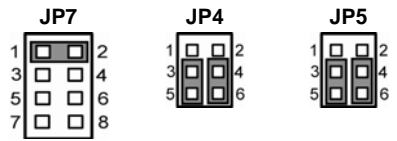
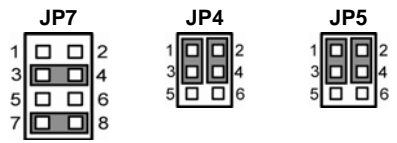
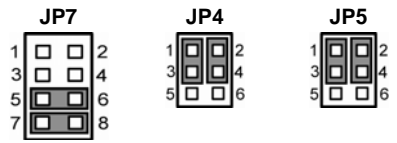
Description	Function	Jumper Setting
COM1	RS-232 (Default)	
	RS-422	
	RS-485	



2.3.5 COM1~COM2 Mode (JP6, JP8)

These jumpers select the COM1 and COM2 ports' DCD and RI mode.

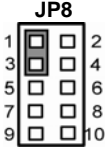
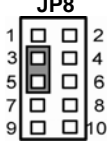
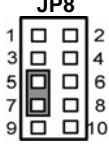
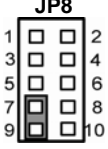
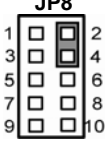
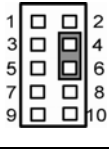
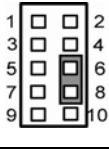
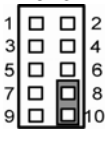
Description	Function	Jumper Setting
COM1 (CN18)	Pin 1=5V	
	Pin 1=12V	
	*Pin 1=DCD	
	Pin 9=5V	
	Pin 9=12V	
	*Pin 9=RI	



Description	Function	Jumper Setting
COM2 (CN13)	Pin 1=5V	 <p>JP8</p> <p>1 2 3 4 5 6 7 8 9 10</p>
	Pin 1=12V	  <p>JP8</p> <p>JP8</p> <p>1 2 3 4 5 6 7 8 9 10</p> <p>1 2 3 4 5 6 7 8 9 10</p>
	*Pin 1=DCD	 <p>JP8</p> <p>1 2 3 4 5 6 7 8 9 10</p>
	Pin 8=5V	 <p>JP8</p> <p>1 2 3 4 5 6 7 8 9 10</p>
	Pin 8=12V	  <p>JP8</p> <p>JP8</p> <p>1 2 3 4 5 6 7 8 9 10</p> <p>1 2 3 4 5 6 7 8 9 10</p>
	*Pin 8=RI	 <p>JP8</p> <p>1 2 3 4 5 6 7 8 9 10</p>

2.3.6 Audio Output Select Jumper (JP9)

Description	Function	Jumper Setting
Audio Output Selection	Line Out	<p>JP9</p> <p>2 4 6</p>  <p>1 3 5</p>
	Speak Out (Default)	<p>JP9</p> <p>2 4 6</p>  <p>1 3 5</p>



2.3.7 Power Selection of Flat Panel 1'ST Connector (VDDM1 of LVDS1) (JP10)

EP810 Series supports 3.3V or +5V flat panel displays. Configure the jumper **JP10** to the appropriate voltage of the flat panel.

Description	Function	Jumper Setting
VDDM1	3.3V (Default)	<p>JP10</p>  <p>1 2 3</p>
	5V	<p>JP10</p>  <p>1 2 3</p>

2.3.8 Power Selection of Flat Panel 2'ND Connector (VDDM2 of LVDS2) (JP11)

EP810 Series supports 3.3V or +5V flat panel displays. Configure the jumper **JP11** to the appropriate voltage of the flat panel.

Description	Function	Jumper Setting
VDDM2	3.3V (Default)	JP11 
	5V	JP11 

2.4 Connectors

The connectors allow the CPU card to connect with other parts of the system. Some problems encountered by your system may be a result from loose or improper connections. Ensure that all connectors are in place and firmly attached. The following table lists the function of each connector on the **EP810 Series**.

Connectors	Label
Power Connector	CN1
External USB Connector	CN2
DIO Connector	CN3
Mini PCI Connector	CN4
IDE Connector	CN5
F.D.D Connector	CN6
1'ST LVDS Inverter Connector	CN7
2'ST LVDS Inverter Connector	CN8
1'ST LVDS Connector	CN9
2'ST LVDS Connector	CN10
Flat Panel Bezel Connector	CN11
Audio Connector	CN12
Com2 Connector	CN13
LPT port Connectors	CN14
1'ST Ethernet Connector	CN15
2'ST Ethernet Connector	CN16
USB Connector	CN17
Com1 Connector	CN18
Keyboard and Mouse Connector	CN19
VGA CRT Connector	CN20
Compact Flash Connector	CN21
DDR SODIMM Socket (Reverse)	DIMM1
FAN Power connector	FAN1

2.4.1 Power Input Connector (CN1)

Use this connector to connect standard power supply +12V & +5V inputs.

Pin	Description	Pin	Description
1	PS_ON	6	+5VSB
2	GND	7	+5V
3	GND	8	+5V
4	+12V	9	N.C.
5	N.C.	10	GND

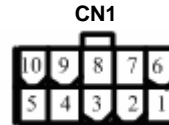

2.4.2 USB1~4 Connectors (CN2, CN17)

The **EP810 Series** features four Universal Serial Bus (USB) connectors as USB 2.0 compliant (480Mbps) that can adapt any USB peripherals, such as monitor, keyboard and mouse etc. The **EP810 Series** has a box-header connectors (**CN2**) and one USB connectors (**CN17**).

Pin	Description	Pin	Description
1	VCC	2	VCC
3	D0-	4	D1-
5	D0+	6	D1+
7	Ground (GND)	8	Ground (GND)
9	Ground (GND)	10	Ground (GND)

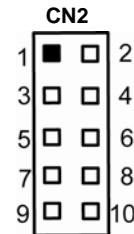

Pin	Description
1	USB Vcc
2	USB -
3	USB +
4	USB GND

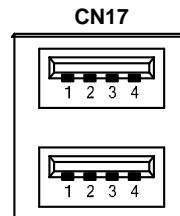

2.4.3 DIO Connector (CN3)

The board is equipped a digital I/O connector **CN3** that meets requirements for a system customary automation control. The digital I/O can be configured to control cash drawers, sense warning signals from an Uninterrupted Power System (UPS), or perform store security control. The digital I/O is controlled via software programming.

Pin	Description	Pin	Description
1	In-0	2	Out-0
3	In-1	4	Out-1
5	In-2	6	Out-2
7	In-3	8	Out-3
9	GND	10	GND

CN3

DIO Address : 40B8

Digital Output				Digital Input			
Bit7	Bit6	Bit5	Bit4	Bit3	Bit2	Bit1	Bit0
Out-3	Out-2	Out-1	Out-0	In-3	In-2	In-1	In-0

2.4.4 Enhanced IDE Interface Connector (CN5)

The **EP810 Series** includes a PCI bus enhanced IDE controller that can support master/slave mode and post write transaction mechanisms with 64-byte buffer and master data transaction.

Pin	Description	Pin	Description	Pin	Description
1	Reset #	2	GND	3	Data 7
4	Data 8	5	Data 6	6	Data 9
7	Data 5	8	Data 10	9	Data 4
10	Data 11	11	Data 3	12	Data 12
13	Data 2	14	Data 13	15	Data 1
16	Data 14	17	Data 0	18	Data 15
19	GND	20	No connector	21	No connector
22	GND	23	IOW #	24	GND
25	IOR #	26	GND	27	IOCHRDY
28	No connector	29	No connector	30	GND-Default
31	Interrupt	32	No connector	33	SA1
34	No connector	35	SA0	36	SA2
37	HDC CS0 #	38	HDC CSI #	39	HDD Active #
40	GND	41	VCC	42	VCC
43	GND	44	N.C		

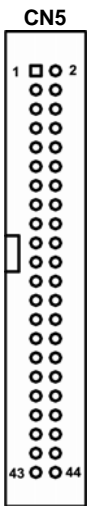

2.4.5 FDD Connector (CN6)

There is one 26-pin FCC Z.I.F. type connector with the general output support for a single floppy drive. The floppy drive could be any one of the following types: 3.5" 720KB or 1.44MB/2.88MB.

Pin	Description	Pin	Description
1	+5V	2	INDEX
3	+5V	4	DRIVE0
5	+5V	6	DSKCHG
7	No connector	8	No connector
9	No connector	10	MOTOR ON
11	No connector	12	DIR
13	No connector	14	STEP
15	GND	16	WDATA
17	GND	18	WGATE

Pin	Description	Pin	Description
19	GND	20	TRK0
21	GND	22	WPT
23	GND	24	RDATA
25	GND	26	HDSEL

FDD1



2.4.6 VGA/LCD Connectors (CN20, CN7, CN8, CN9, CN10)

The **EP810 Series** has several connectors that support CRT VGA and flat panel displays. **CN20** is a standard 15-pin pin header connector commonly used for the CRT VGA display, and **CN9/CN10** JST SHDR-40V-S-B 40-pin connectors for the LVDS flat panel connection that we strongly recommend you to use matching JST SHDR-40V-S-B connector. The **CN7** and **CN8** are DF13-7S-1.25C 7pin connectors for inverter that we strongly recommend you to use matching DF13-7S-1.25C connector.

CN20: CRT/VGA Connector Pin Assignment

Pin	Description	Pin	Description	Pin	Description
1	Red	2	Green	3	Blue
4	N/A	5	GND	6	GND
7	GND	8	AGND	9	VCC
10	GND	11	N/A	12	DDC DAT
13	Horizontal Sync	14	Vertical Sync	15	DDC CLK

CN20

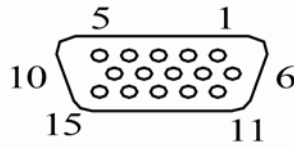

CN9/CN10: JST SHDR-40V-S-B Connectors for LVDS Flat Panel

Pin	Deception	Pin	Deception
1	VCCM	2	VCCM
3	VCCM	4	VCCM
5	VCCM	6	VCCM
7	N.C.	8	N.C.
9	GND	10	GND
11	Channel B D3-	12	Channel B D0-
13	Channel B D3+	14	Channel B D0+
15	GND	16	GND
17	Channel B CLK-	18	Channel B D1-
19	Channel B CLK+	20	Channel B D1+
21	GND	22	GND
23	Channel A D0-	24	Channel B D2-
25	Channel A D0+	26	Channel B D2+
27	GND	28	GND
29	Channel A D1-	30	Channel A D3-
31	Channel A D1+	32	Channel A D3+
33	GND	34	GND
35	Channel A D2-	36	Channel A CLK-
37	Channel A D2+	38	Channel A CLK+
39	GND	40	GND

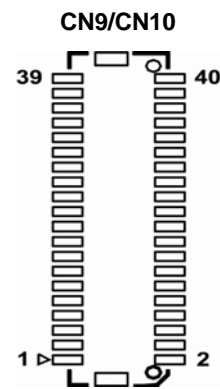

The LVDS interface with 40-pin connectors supports 18/24-bit single/dual channel LCD.

CN7/CN8: DF13-7S-1.25C Connectors for Inverter

Pin	Description
1	12V
2	12V
3	5V
4	ENAB
5	GND
6	GND
7	GND

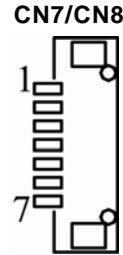

2.4.7 Flat Panel Bezel Connector (CN11)

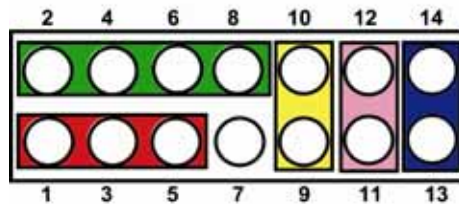

■ **Power LED**

This 3-pin connector named as Pin 1, 3 and 5 connects the system power LED indicator to such a switch on the case. Pin 1 is assigned as +, and Pin 3 and 5 as -. The Power LED lights up when the system is powered ON.

■ **External Speaker and Internal Buzzer Connector**

Pin 2, 4, 6 and 8 can be connected to the case-mounted speaker unit or internal buzzer. While connecting the CPU card to an internal buzzer, you need to short pins 2-4; while connecting to an external speaker, set pins 2-4 to Open and connect the speaker cable to pin 8 (+) and pin 2 (-).

■ **ATX Power On/Off Button**

This 2-pin connector named as Pin 9 and 10 connects the front panel's ATX power button to the CPU card, which allows users to control ATX power supply to be on/off.

■ **System Reset Switch**

Pin 11 and 12 can be connected to the case-mounted reset switch that reboots your computer instead of turning OFF the power switch. It is a better way to reboot your system for a longer life of the system's power supply.

■ **HDD Activity LED**

This connection is linked to hard drive activity LED on the control panel. LED flashes when HDD is being accessed. Pin 13 and 14 connect the hard disk drive to the front panel HDD LED, Pin 13 assigned as -, and Pin 14 as +.

2.4.8 Audio Connector (CN12)

The **EP810 Series** supports audio interface. **CN12** is a 10pin-header connector commonly used for the audio.

Pin	Description	Pin	Description
1	MIC-IN	2	GND
3	Line In L	4	GND
5	Line In R	6	GND
7	Audio Out L	8	GND
9	Audio Out R	10	GND

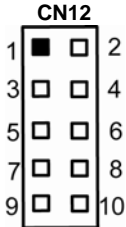

2.4.9 Serial Port Interface (CN13, CN18)

COM1 Port Connector: CN18

The connector COM1 (CN18) is a DB-9 connector, and the following pin assignment table for your reference.

Pin	Description
1	DCD, Data carrier detect
2	RXD, Receive data
3	TXD, Transmit data
4	DTR, Data terminal ready
5	GND, ground
6	DSR, Data set ready
7	RTS, Request to send
8	CTS, Clear to send
9	RI, Ring indicator

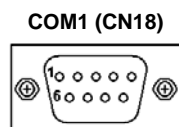

The COM1 RS-422/485 pin assignment

Pin	Description	
	R2-422	RS-485
1	TX-	DATA-
2	TX+	DATA+
3	RX+	No connector
4	RX-	No connector

COM2 Port Connectors: CN13

The RS-232 pin assignments are listed on the following table.

Pin	Description	Pin	Description
1	Data Carrier Detect (DCD)	2	Data Set Ready (DSR)
3	Receive Data (RXD)	4	Request to Send (RTS)
5	Transmit Data (TXD)	6	Clear to Send (CTS)
7	Data Terminal Ready (DTR)	8	Ring Indicator (RI)

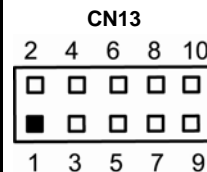

9	Ground (GND)	10	NC
---	--------------	----	----

2.4.10 Parallel Port (CN14)

The **EP810 Series** has a multi-mode parallel port, **CN14**, to support:

1. **Standard mode:**
IBM PC/XT, PC/AT and PS/2™ compatible with bi-directional parallel port
2. **Enhanced mode:**
Enhance parallel port (EPP) compatible with EPP 1.7 and EPP 1.9 (IEEE 1284 compliant)
3. **High speed mode:**
Microsoft and Hewlett Packard extended capabilities port (ECP)
IEEE 1284 compliant

The address select of the onboard parallel port in LPT1 (3BCH) or disabled is done by BIOS CMOS setup.

Pin	Description	Pin	Description
1	Strobe#	2	Auto Form Feed#
3	Data 0	4	Error#
5	Data 1	6	Initialize#
7	Data 2	8	Printer Select In#
9	Data 3	10	GND
11	Data 4	12	GND
13	Data 5	14	GND
15	Data 6	16	GND
17	Data 7	18	GND
19	Acknowledge#	20	GND
21	Busy	22	GND
23	Paper Empty#	24	GND
25	Printer Select	26	NC

CN14

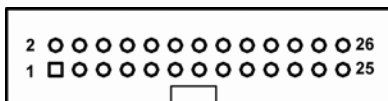

2.4.11 Ethernet RJ-45 Connectors (CN15, CN16)

The **EP810 Series** is equipped with a high performance Plug and Play Ethernet interface which is fully compliant with the IEEE 802.3 standard, and consisting of a RJ-45 connector LAN.

LAN: RJ-45 Connector Pin Assignment

Pin	Description
1	Tx+ (Data transmission positive)
2	Tx- (Data transmission negative)
3	Rx+(Data reception positive)
4	RJ45 termination
5	RJ45 termination
6	Rx- (Data reception negative)
7	RJ45 termination
8	RJ45 termination

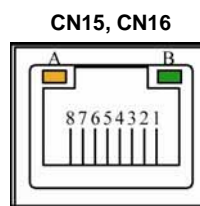

Feature

- 10Mb/s and 100Mb/s operations
- Supports 10Mb/s and 100Mb/s N-Way auto negotiation
- Full duplex capability
- Full compliance with PCI Revision 2.1
- PCI Bus Master data transfers

Drivers Supported

Bundled with popular software drivers, the **EP810 Series** Ethernet interface allows great flexibility to work with all major networking operating systems including Novell NetWare v2.x, v3.x, v4.x, Microsoft LAN Manager, Win3.1, Win NT, Win95, IBM LAN Server, SCO UNIX or other ODI, NDIS and Packet drive compliant operating

systems.

2.4.12 Keyboard and PS/2 Mouse Connector (CN19)

The **EP810 Series** provides a keyboard and Mouse interface. **CN19** is a DIN connector for PS/2 keyboard Connection VIA “Y” Cable.

Pin	Description
1	Keyboard Data
2	Mouse Data
3	GND
4	VCC
5	Keyboard Clock
6	Mouse Clock

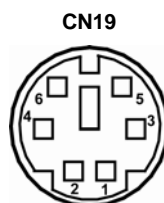

2.4.13 CompactFlash Connector (CN21)

The **EP810 Series** Series is equipped with a CompactFlash disk type-II socket on the solder side and it supports the IDE interface CompactFlash disk card with DMA mode supported. The socket itself is especially designed to prevent any incorrect installation of the CompactFlash disk card.

When installing or removing the CompactFlash disk card, please make sure that the system power is off.

The CompactFlash disk card is defaulted as the C: or D: disk drive in your PC system.

Pin	Description	Pin	Description
1	GND	2	Data 3
3	Data 4	4	Data 5
5	Data 6	6	Data 7
7	CS0#	8	Address 10
9	ATASEL	10	Address 9
11	Address 8	12	Address 7
13	VCC	14	Address 6
15	Address 5	16	Address 4
17	Address 3	18	Address 2
19	Address 1	20	Address 0

Pin	Description	Pin	Description
21	Data 0	22	Data 1
23	Data 2	24	IOCS16#
25	CD2#	26	CD1-
27	Data 11	28	Data 12
29	Data 13	30	Data 14
31	Data 15	32	CS1#
33	VS1#	34	IOR#
35	IOWR#	36	WE#
37	INTR	38	VCC
39	CSEL#	40	VS2#
41	RESET#	42	IORDY#
43	DMAREQ	44	DMAACK-
45	DASP#	46	PDIAG#
47	Data 8	48	Data 9
49	Data 10	50	GND

CN21: CompactFlash Socket

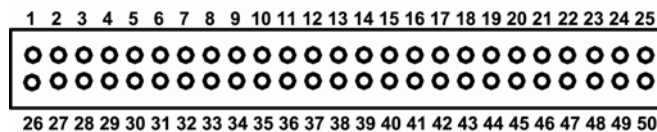

2.4.14 CPU Fan Connector (FAN1)

FAN1 is a CPU fan connector. Pentium microprocessors require a fan for heat dispensing. The fan connector on EP810 Series provides power to the fan.

Pin	Description
1	GND
2	+12V
3	Sensor

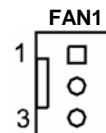

MEMO

Chapter 3

Hardware Description

3.1 Microprocessors

The **EP810 Series** supports Intel® Celeron™ M and Pentium® M CPUs. Systems based on these CPUs can be operated under Windows 2000/XP and Linux environments. The system performance depends on the microprocessor installed onboard. Make sure all settings are correct for the installed microprocessor to prevent any damage to the CPU.

3.2 BIOS

System BIOS used on the **EP810 Series** is Phoenix-Award Plug and Play BIOS. The **EP810 Series** contains a single 4Mbit Flash.

3.3 System Memory

The **EP810 Series** industrial CPU card supports one 200-pin DDR SODIMM socket for a maximum memory of 1GB DDR SDRAMs. The memory module can come in sizes of 64MB, 128MB, 256MB, 512MB and 1GB.

3.4 I/O Port Address Map

The Intel® Pentium® M/Celeron™ M CPU communicates via I/O ports. It has a total of 1KB port addresses available for assignment to other devices via I/O expansion cards.

Address	Devices
000-01F	DMA controller #1
020-03F	Interrupt controller #1
040-05F	Timer
060-06F	Keyboard controller
070-07F	Real time clock, NMI
080-09F	DMA page register
0A0-0BF	Interrupt controller #2
0C0-0DF	DMA controller #2
0F0	Clear math coprocessor busy signal
0F1	Reset math coprocessor
0F8-0FF	Math processor
1F0-1F8	Fixed disk controller
250-25F	HR I/O
300-31F	Prototype card
380-38F	SDLC #2
3A0-3AF	SDLC #1
3B0-3BF	MDA video card (including LPT1)
3C0-3CF	EGA card
3D0-3DF	CGA card
3F0-3F7	Floppy disk controller
3F8-3FF	Serial port #1 (COM1)
3E8-3EF	
2F8-2FF	Serial port #2 (COM2)
2E8-2EF	
3F0-3FF	Super I/O

3.5 Interrupt Controller

The **EP810 Series** is a 100% PC compatible control board. It consists of 16 interrupt request lines. Four out of the sixteen can either be programmable. The mapping list of the 16 interrupt request lines is shown on the following table.

NMI	Parity check error
IRQ0	System timer output
IRQ1	Keyboard
IRQ2	Interrupt rerouting from IRQ8 through IRQ15
IRQ3	Serial port #2
IRQ4	Serial port #1
IRQ5	Reserved
IRQ6	Floppy disk controller
IRQ7	Parallel port #1
IRQ8	Real time clock
IRQ9	Reserved
IRQ10	
IRQ11	
IRQ12	PS/2 Mouse
IRQ13	Math coprocessor
IRQ14	Primary IDE channel
IRQ15	Secondary IDE Channel

MEMO

Chapter 4

Award BIOS Utility

The Phoenix-Award BIOS provides users with a built-in Setup program to modify basic system configuration. All configured parameters are stored in a battery-backed-up RAM (CMOS RAM) to save the Setup information whenever the power is turned off.

4.1 Entering Setup

There are two ways to enter the Setup program. You may either turn ON the computer and press immediately, or press the and/or <Ctrl>, <Alt>, and <Esc> keys simultaneously when the following message appears at the bottom of the screen during POST (Power on Self Test).

TO ENTER SETUP PRESS DEL KEY

If the message disappears before you respond and you still want to enter Setup, please restart the system to try it again. Turning the system power OFF and ON, pressing the "RESET" button on the system case or simultaneously pressing <Ctrl>, <Alt>, and keys can restart the system. If you do not press keys at the right time and the system doesn't boot, an error message will pop out to prompt you the following information:

PRESS <F1> TO CONTINUE, <CTRL-ALT-ESC> OR TO ENTER SETUP

4.2 Control Keys

Up arrow	Move cursor to the previous item
Down arrow	Move cursor to the next item
Left arrow	Move cursor to the item on the left hand
Right arrow	Move to the item in the right hand
Esc key	Main Menu -- Quit and delete changes into CMOS Status Page Setup Menu and Option Page Setup Menu -- Exit current page and return to Main Menu
PgUp/“+” key	Increase the numeric value or make changes
PgDn/“-“ key	Decrease the numeric value or make changes
F1 key	General help, only for Status Page Setup Menu and Option Page Setup Menu
(Shift) F2 key	Change color from total 16 colors. F2 to select color forward, (Shift) F2 to select color backward
F3 key	Reserved
F4 key	Reserved
F5 key	Restore the previous CMOS value from CMOS, only for Option Page Setup Menu
F6 key	Load the default CMOS value from BIOS default table, only for Option Page Setup Menu
F7 key	Load the Setup default, only for Option Page Setup Menu
F8 key	Reserved
F9 key	Reserved
F10 key	Save all the CMOS changes, only for Main Menu

4.3 Getting Help

- **Main Menu**
The online description of the highlighted setup function is displayed at the bottom of the screen.
- **Status Page Setup Menu/Option Page Setup Menu**
Press <F1> to pop out a small Help window that provides the description of using appropriate keys and possible selections for highlighted items. Press <F1> or <Esc> to exit the Help Window.

4.4 The Main Menu

Once you enter the Award BIOS CMOS Setup Utility, the Main Menu appears on the screen. In the Main Menu, there are several Setup functions and a couple of Exit options for your selection. Use arrow keys to select the Setup Page you intend to configure then press <Enter> to accept or enter its sub-menu.

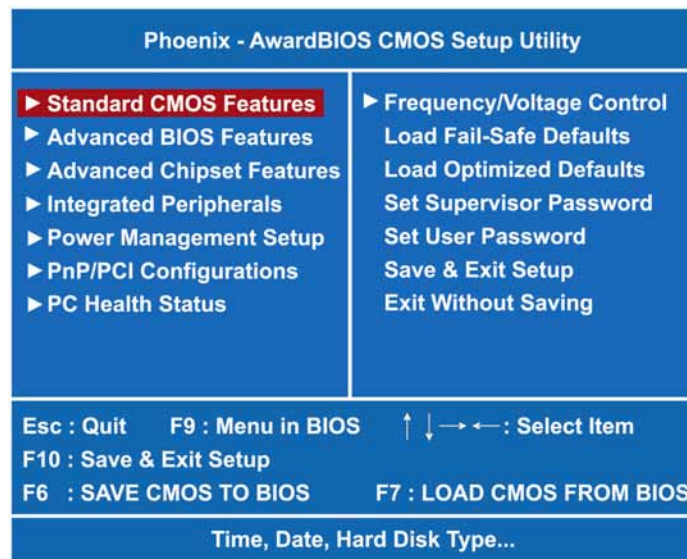

 **NOTE** If your computer can not boot after making and saving system changes with Setup, the Award BIOS will reset your system to the CMOS default settings via its built-in override feature.

It is strongly recommended that you should avoid changing the chipset's defaults. Both Award and your system manufacturer have carefully set up these defaults that provide the best performance and reliability.

4.5 Standard CMOS Setup Menu

The items in Standard CMOS Setup Menu are divided into 10 categories. Each category includes no, one or more than one setup items. Use the arrow keys to highlight the item and then use the <PgUp> or <PgDn> keys to select the value you want in each item.

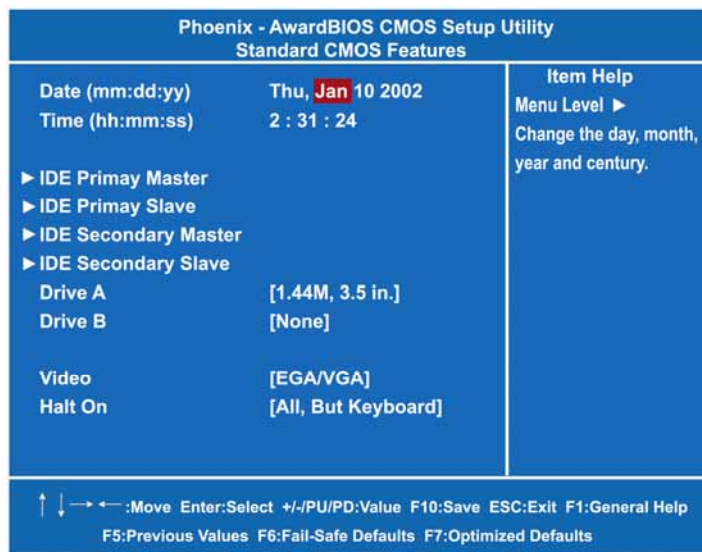

- **Date**

day	It is determined by the BIOS and read only, from Sunday to Saturday.
date	It can be keyed with the numerical/ function key, from 1 to 31.
month	It is from January to December.
year	It shows the current year of BIOS.

- **Time**

This item shows current time of your system with the format <hour> <minute> <second>. The time is calculated based on the 24-hour military-time clock. For example, 1 p.m. is 13:00:00.

- **IDE Primary Master/Primary Slave**

These items identify the types of each IDE channel installed in the computer. There are 45 predefined types (Type 1 to Type 45) and 2 user's definable types (Type User) for Enhanced IDE BIOS.

Press <PgUp>/<+> or <PgDn>/<-> to select a numbered hard disk type, or directly type the number and press <Enter>. Please be noted your drive's specifications must match the drive table.

The hard disk will not work properly if you enter improper information. If your hard disk drive type does not match or is not listed, you can use Type User to manually define your own drive type.

If selecting Type User, you will be asked to enter related information in the following items. Directly key in the information and press <Enter>. This information should be provided in the documentation from your hard disk vendor or the system manufacturer.

If the HDD interface controller supports ESDI, select "Type 1".

If the HDD interface controller supports SCSI, select "None".

If the HDD interface controller supports CD-ROM, select "None".

CYLS.	number of cylinders	LANDZONE	landing zone
HEADS	number of heads	SECTORS	number of sectors
PRECOMP	write precom	MODE	HDD access mode

If there is no hard disk drive installed, select NONE and press <Enter>.

- **Dive A type/Drive B type**

The item identifies the types of floppy disk installed in the computer, as drive A or drive B.

None	No floppy drive installed
360K, 3.5 in	3.5 inch PC-type standard drive; 360Kb Mini ITXcity
1.2M, 3.5 in	3.5 inch AT-type high-density drive; 1.2MB Mini ITXcity
720K, 3.5 in	3.5 inch double-sided drive; 720Kb Mini ITXcity
1.44M, 3.5 in	3.5 inch double-sided drive; 1.44MB Mini ITXcity
2.88M, 3.5 in	3.5 inch double-sided drive; 2.88MB Mini ITXcity

- **Video**

Select the display adapter type for your system.

- **Halt On**

This item determines whether the system will halt or not, if an error

is detected while powering up.

No errors	The system booting will halt on any errors detected. (default)
All errors	Whenever BIOS detects a non-fatal error, the system will stop and you will be prompted.
All, But Keyboard	The system booting will not stop for a keyboard error; it will stop for other errors.
All, But Diskette	The system booting will not stop for a disk error; it will stop for other errors.
All, But Disk/Key	The system booting will not stop for a keyboard or disk error; it will stop for other errors.

Press <Esc> to return to the Main Menu page.

4.6 Advanced BIOS Features

This section allows you to configure and improve your system, to set up some system features according to your preference.

Phoenix - AwardBIOS CMOS Setup Utility		
Advanced BIOS Features		
▶ CPU Feature	[Press Enter]	Item Help
▶ Hard Disk Boot Priority	[Press Enter]	Menu Level ▶
Virus Warning	[Disabled]	
CPU L1 & L2 Cache	[Enabled]	
CPU L2 Cache	[Enabled]	
Quick Power On Shelf Test	[Enabled]	
First Boot Device	[HDD-0]	
Second Boot Device	[Floppy]	
Third Boot Device	[SCSI]	
Boot Other Device	[Enabled]	
Swap Floppy Drive	[Disabled]	
Boot Up Floppy Seek	[Enabled]	
Boot Up NumLock Status	[On]	
Gate A20 Option	[Fast]	
Typematic Rate Setting	[Disabled]	
X Typematic Rate (Chars/Sec)	6	
X Typematic Delay (Msec)	250	
Security Option	[Setup]	
APIC Mode	[Enabled]	
PS/2 Mouse Function Control	[Enabled]	
OS Select For DRAM>64MB	[Non-OS2]	
Report No FDD For WIN 95	[No]	
Full Screen Logo Show	[Disabled]	
Small Screen Show	[Disabled]	
Summary Screen Show	[Enabled]	
Display board ID	[Disabled]	

↑ ↓ ← → : Move Enter: Select +/-/PU/PD: Value F10: Save ESC: Exit F1: General Help
 F5: Previous Values F6: Fail-Safe Defaults F7: Optimized Defaults

- **Hard Disk Boot Priority**

Use this item to select the disk boot priority.

- **Virus Warning**

This option flashes on the screen. During and after the system boot up, any attempt to write to the boot sector or partition table of the hard disk drive will halt the system with the following message. You can run an anti-virus program to locate the problem. The default setting is “Disabled”.

! WARNING !

Disk boot sector is to be modified

Type “Y” to accept write or “N” to abort write

Award Software, Inc.

Enabled	It automatically activates while the system boots up and a warning message appears for an attempt to access the boot sector or hard disk partition table.
Disabled	No warning message will appear for attempts to access the boot sector or hard disk partition table.



NOTE: This function is only available with DOS and other operating systems that do not trap INT13.

- **CPU L1 & L2 Cache**

These two options speed up memory access. However, it depends on the CPU/chipset design. The default setting is “Enabled”. CPUs without built-in internal cache will not provide the “CPU Internal Cache” item on the menu.

Enabled	Enable cache
Disabled	Disable cache

- **Quick Power On Self Test**

This option speeds up Power on Self Test (POST) after you turn on the system power. If set as Enabled, BIOS will shorten or skip some check items during POST. The default setting is “Enabled”.

Enabled	Enable Quick POST
Disabled	Normal POST

- **First/Second/Third Boot Device**

These items let you select the 1st, 2nd, and 3rd devices that the system will search for during its boot-up sequence. The wide range of selection includes Floppy, LS120, ZIP100, HDD0~3, SCSI, and CDROM.

- **Boot Other Device**

This item allows users to enable or disable the boot device not listed in the First/Second/Third boot devices option above. The default setting is “*Enabled*”.

- **Swap Floppy Drive**

This item allows you to determine whether to enable Swap Floppy Drive or not. When enabled, the BIOS swap floppy drive assignment makes Drive A become Drive B, and vice versa. The default setting is “*Disabled*”.

- **Boot Up Floppy Seek**

During POST, BIOS will determine the floppy disk drive type, 40 or 80 tracks. The 360Kb type is 40 tracks while 720Kb, 1.2MB and 1.44MB are all 80 tracks. The default value is “*Enabled*”.

Enabled	BIOS searches for floppy disk drive to determine if it is 40 or 80 tracks. Please be noted BIOS can not differentiate 720K, 1.2M or 1.44M drive type as they all are 80 tracks.
Disabled	BIOS will not search for the type of floppy disk drive by track number. There will be no warning message displayed if the installed drive is 360K.

- **Boot Up NumLock Status**

Set the the Num Lock status when the system is powered on. The default value is “*On*”.

- **Gate A20 Option**

The default value is “*Fast*”.

Normal	The A20 signal is controlled by keyboard controller or chipset hardware.
Fast	Default: Fast. The A20 signal is controlled by Port 92 or chipset specific method.

- **Typematic Rate Setting**

This item determines the typematic rate of the keyboard. The default value is “*Disabled*”.

Enabled	Enable typematic rate and typematic delay programming.
Disabled	Disable typematic rate and typematic delay programming. The system BIOS will use default value of these 2 items, controlled by keyboard.

- **Typematic Rate (Chars/Sec)**

This option refers to character numbers typed per second by the keyboard. The default value is “6”.

6	6 characters per second
8	8 characters per second
10	10 characters per second
12	12 characters per second
15	15 characters per second
20	20 characters per second
24	24 characters per second
30	30 characters per second

- **Typematic Delay (Msec)**

This option defines how many milliseconds must elapse before a held-down key begins generating repeat characters. The default value is “250”.

250	250 msec
500	500 msec
750	750 msec
1000	1000 msec

- **Security Option**

This item allows you to limit access to the system and Setup, or just to Setup. The default value is “Setup”.

System	If a wrong password is entered at the prompt, the system will not boot, the access to Setup will be denied, either.
Setup	If a wrong password is entered at the prompt, the system will boot, but the access to Setup will be denied.



NOTE To disable the security, select **PASSWORD SETTING** at Main Menu and then you will be asked to enter a password. Do not type anything, just press <Enter> and it will disable the security. Once the security is disabled, the system will

boot and you can enter Setup freely.

- **APIC Mode**
Use this item to enable or disable APIC (Advanced Programmable Interrupt Controller) mode that provides symmetric multi-processing (SMP) for systems.
- **PS/2 Mouse Function Control**
Use this item to set the use of PS/2 mouse or not. If there is a PS/2 mouse connected to your system, please enable this item.
- **OS Select for DRAM >64MB**
This item allows you to access the memory over 64MB in OS/2.
- **Report No FDD For WIN 95**
Select Yes to release an IRQ when the system doesn't have any floppy drive, for compatibility with Windows 95 logo certification. In the Integrated Peripherals screen, select Disabled for the Onboard FDC Controller field.

Press <Esc> to return to the Main Menu page.

4.7 Advanced Chipset Features

This section contains completely optimized chipset's features on the board that you are strongly recommended to leave all items on this page at their default values unless you are very familiar with the technical specifications of your system hardware.

Phoenix - AwardBIOS CMOS Setup Utility Advanced Chipset Features		
DRAM Timing Selectable	[By SPD]	Item Help Menu Level ►
CAS Latency Time	[2.5]	
Active to Recharge Delay	[7]	
DRAM RAS# to CAS# Delay	[3]	
DRAM RAS# Precharge	[3]	
DRAM Data Integrity Mode	[Non-ECC]	
MGM Core Frequency	[Auto Max 400/333MHz]	
System BIOS Cacheable	[Enabled]	
Video BIOS Cacheable	[Disabled]	
Memory Hole At 15M-16M	[Disabled]	
Delayed Transaction	[Disabled]	
Delay Prior to Thermal	[16 Min]	
AGP Apterture Size (MB)	[64]	
Init Display First	[Onboard]	
** On-Chip VGA Setting **		
On-Chip VGA	[Enabled]	
On-Chip Frame Buffer Size	[32MB]	
Boot Display	[Auto]	
Panel Scaling	[Auto]	
Panel Number	[640x480]	
↑ ↓ ← → :Move Enter:Select +/-/PU/PD:Value F10:Save ESC:Exit F1:General Help F5:Previous Values F6 : Fail-Safe Defaults F7:Optimized Default		

- DRAM Timing**
 Use this item to enable or disable the SDRAM timing, which can be defined by Serial Presence Detect.
- CAS Latency Time**
 You can select CAS latency time to HCLKs 2, 3, or Auto. The board designer should have set up these values in accordance with the installed DRAM. Do not change these values unless you have to change the specifications of the installed DRAM or CPU.

- **DRAM RAS# to CAS# Delay**
When DRAM is refreshed, both rows and columns are addressed separately. This field lets you insert a timing delay between the CAS and RAS strobe signals, used when DRAM is written to, read from, or refreshed.
- **DRAM RAS# Precharge**
The precharge time is the number of cycles it takes for the RAS to accumulate its charge before DRAM refresh. If insufficient time is allowed, refresh may be incomplete and the DRAM may fail to retain data.
- **DRAM Data Integrity Mode**
Use this item to set data integrity mode of the DRAM installed in the system. The default setting is "Non-ECC".
- **MGM Core Frequency**
Use this item to set the clock ratio of CPU and system.
- **System BIOS Cacheable**
Selecting Enabled allows caching of the system BIOS ROM at F0000h-FFFFFh, resulting in better system performance. However, if any program writes to this memory area, a system error may result. The default value is "Disabled".
- **Video BIOS Cacheable**
This item allows you to change the Video BIOS location from ROM to RAM. Video Shadow will increase the video speed.
- **Memory Hole At 15M-16M**
You can reserve this area of system memory for ISA adapter ROM. When this area is reserved, it cannot be cached. The user information of peripherals that need to use this area of system memory usually discusses their memory requirements.
- **Delayed Transaction**
The chipset has an embedded 32-bit posted write buffer to support delay transactions cycles. Select "Enabled" to support PCI specification version 2.1. The options available are "Enabled" and "Disabled".
- **AGP Aperture Size (MB)**
Use this item to set aperture size of the graphics. The aperture is a portion of the PCI memory address range dedicated for graphics memory address space. Host cycles that hit the aperture

range are forwarded to the AGP without any translation. The options available are "4M", "8M", "16M", "32M", "64M", "128M" and "256M".

- **Init Display First**

This item allows you to decide whether PCI Slot or AGP to be the first primary display card.

***** On-Chip VGA Setting *****

- **On-Chip VGA**

Use this item to choose the primary display card.

- **On-Chip Frame Buffer Size**

Use this item to set the VGA frame buffer size.

- **Boot Display**

This item is for Intel define ADD card only.

Press <Esc> to return to the Main Menu page.

4.8 Integrated Peripherals

This section allows you to configure your SuperIO Device, IDE Function and Onboard Device.

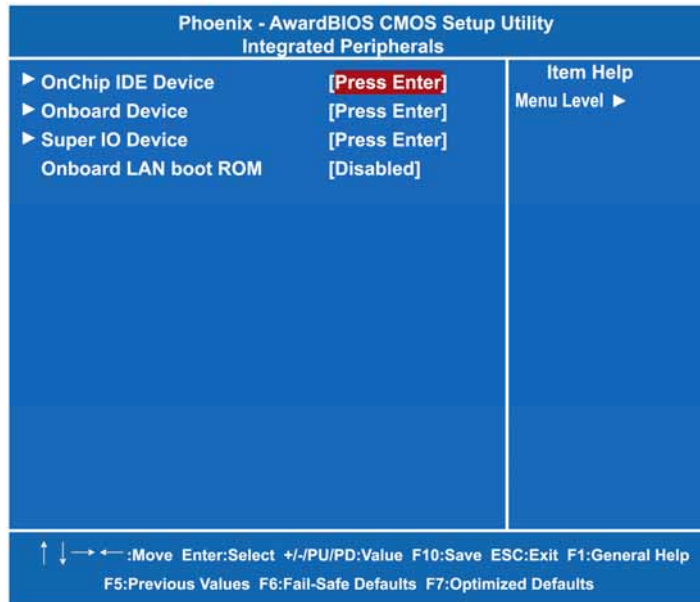

● **OnChip IDE Device**

Scroll to this item and press <Enter> to view the VIA OnChip IDE Device sub menu.

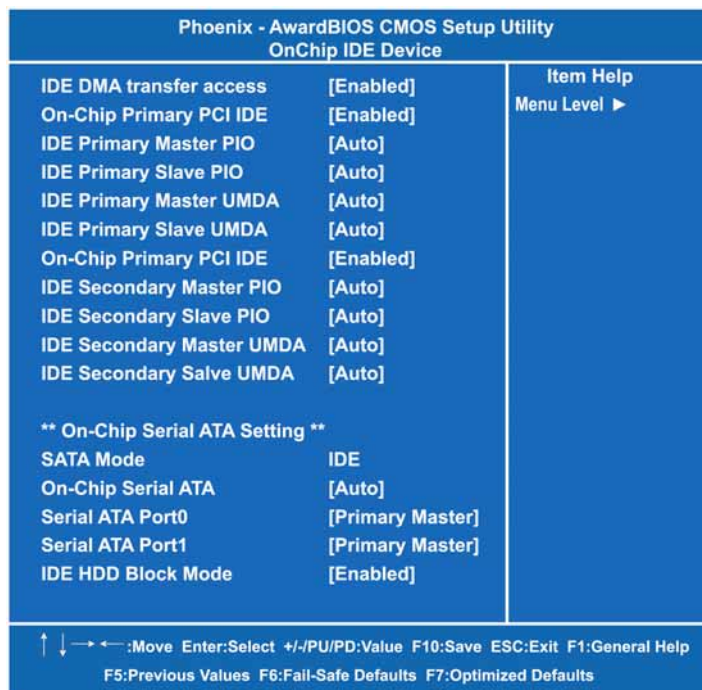

➤ **IDE DMA transfer access**

Automatic data transfer between system memory and IDE device with minimum CPU intervention. This improves data throughput and frees CPU to perform other tasks.

➤ **On-Chip Primary/Secondary PCI IDE**

The integrated peripheral controller contains an IDE interface with support for two IDE channels. Select Enabled to activate each channel separately. The default value is "Enabled".



NOTE Choosing Disabled for these options will automatically remove the IDE Primary Master/ Slave PIO and/or IDE Secondary Master/Slave PIO items on the menu.

- **IDE Primary/Secondary Master/Slave PIO**
The four IDE PIO (Programmed Input/Output) fields let you set a PIO mode (0-4) for each of the four IDE devices that the onboard IDE interface supports. Modes 0 to 4 provide successively increased performance. In Auto mode, the system automatically determines the best mode for each device.
- **IDE Primary/Secondary Master/Slave UDMA**
Select the mode of operation for the IDE drive. Ultra DMA-33/66/100/133 implementation is possible only if your IDE hard drive supports it and the operating environment includes a DMA driver. If your hard drive and system software both support Ultra DMA-33/66/100/133, select Auto to enable UDMA mode by BIOS.

***** On-Chip Serial ATA Setting *****

- **SATA Mode**
There are these options for you to set up SATA mode: IDE, RAID or AHCI.
- **On-Chip Serial ATA**
Use this item to enable or disable the built-in on-chip serial ATA.
- **SATA Port 0/1**
If the "PATA IDE Mode" is Primary, it will show " P1, P3 is Secondary" which means SATA 2 and SATA 4 are Secondary. If the "PATA IDE Mode " is Secondary, it will show " P0, P2 is Primary " which means SATA 1 and SATA 3 are Primary.

Press <Esc> to return to the Integrated Peripherals page.

- **Onboard Device**

Scroll to this item and press <Enter> to view the Onboard Device sub menu.

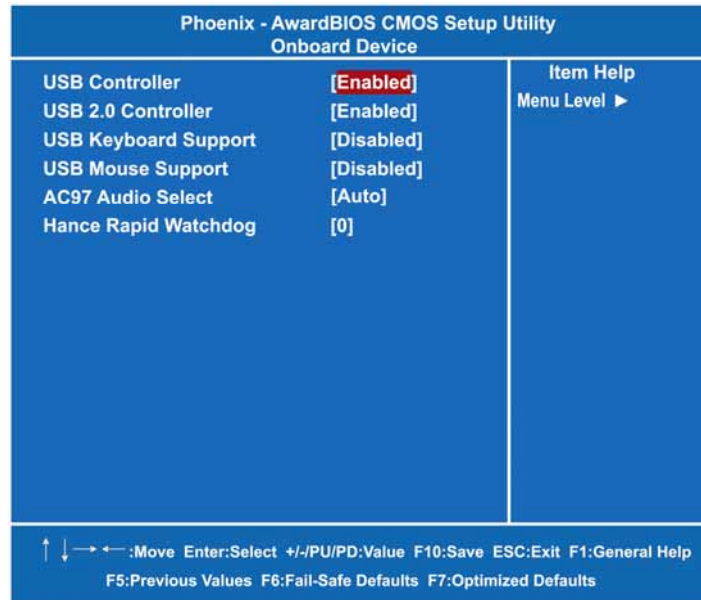

- **USB Controller**
Enable this item if you are using the USB in the system. You should disable this item if a higher-level controller is added.
- **USB 2.0 Controller**
Enable this item if you are using the EHCI (USB2.0) controller in the system.
- **USB Keyboard Support**
Enable this item if the system has a Universal Serial Bus (USB) controller, and you have a USB keyboard.
- **USB Mouse Support**
Enable this item to boot the hard drive by a USB mouse.
- **AC'97 Audio Select**
Use this item to enable or disable the onboard AC'97 Audio function.

Press <Esc> to return to the Integrated Peripherals page.

- **Super I/O Device**

Scroll to this item and press <Enter> to view the Super I/O Device sub menu.

Phoenix - AwardBIOS CMOS Setup Utility		
Super IO Device		
Onboard FDC Controller	[Enabled]	Item Help Menu Level ▶
Onboard Serial Port 1	[3F8/IRQ4]	
Onboard Serial Port 2	[2F8/IRQ3]	
UART Mode Select	[Normal]	
Rxd, TxD Active	[Hi, Lo]	
IR Transmission Delay	[Enabled]	
UR2 Duplex Mode	[Half]	
Use IR Pins	[IR-Rx2Tx2]	
Onboard Parallel Port	[378/IRQ7]	
Parallel Port Mode	[SPP]	
EPP Mode Select	EPP1.7	
ECP Mode Use DMA	3	
ICH Serial Port1	[3E8]	
ICH Serial Port1 Use IRQ	[IRQ10]	
ICH Serial Port2	[2E8]	
ICH Serial Port2 Use IRQ	[IRQ11]	
PWRON After PWR-Fail	[OFF]	

↑ ↓ → ← :Move Enter:Select +/-/PU/PD:Value F10:Save ESC:Exit F1:General Help
F5:Previous Values F6:Fail-Safe Defaults F7:Optimized Defaults

- **Onboard FDC Controller**
Select Enabled, if your system has a floppy disk controller (FDC) installed on the system board and you want to use it. If you install and-in FDC or the system has no floppy drive, select Disabled in this field. Options: Enabled and Disabled.
- **Onboard Serial Port 1/2**
Select an address and corresponding interrupt for the serial port. Options are: "3F8/IRQ4", "2F8/IRQ3", "3E8/IRQ10", "2E8/IRQ11", "338/IRQ5", "238/IRQ7", "Auto" and "Disabled".
- **URAT Mode Select**
When UART Mode Select is set as ASKIR or IrDA, the options RxD, TxD Active and IR Transmission delay will appear.
- **RxD, TxD Active**
When the IR transmission is enabled, you can set up speeds of reception (RxD) and transmission (TxD).

- **IR Transmission Delay**
Enable or disable this item to decide if the IR transmission delay function will be set or not while transferring to the reception mode.
- **UAR2 Duplex Mode**
The second serial port offers these infrared interface modes:
 1. IrDA
 2. ASKIR IrDA-compliant serial infrared port
 3. Normalo (default value)



NOTE *The UART Mode Select will not appear on the menu once you disable the setting of Onboard Serial Port 2.*

- **Use IR Pins**
Use this item to set up IR devices based on the IR pin definitions.
- **Onboard Parallel Port**
This item allows you to determine the I/O address for onboard parallel port. Options are: "378H/IRQ7", "278H/IRQ5", "3BC/IRQ7" and "Disabled".
- **Parallel Port Mode**
Select an operating mode for the onboard parallel (printer) port. Select Normal unless your hardware and software require another mode in this field. Options are: "EPP1.9", "ECP", "SPP", "ECPEPP1.7" and "EPP1.7".
- **EPP Mode Select**
Select EPP port type 1.7 or 1.9.
- **ECP Mode Use DMA**
Select a DMA channel for the parallel port while using the ECP mode.
- **PWRON After PWR-Fail**
This item enables your computer to automatically restart or return to its operating status.

Press <Esc> to return to the Integrated Peripherals page.

- **Onboard LAN boot ROM**

Use this item to enable or disable the Boot ROM function of the onboard LAN chip when the system boots up.

Press <Esc> to return to the Main Menu page.

4.9 Power Management Setup

The Power Management Setup allows you to save energy of your system effectively. It will shut down the hard disk and turn OFF video display after a period of inactivity.

Phoenix - AwardBIOS CMOS Setup Utility		Item Help
Power Management Setup		Menu Level ▶
ACPI Function	[Disabled]	
ACPI Suspend Type	[S1(POS)]	
Power Management	[Min Saving]	
PM Control by APM	[Yes]	
Video Off Method	[V/H AYNX+Blank]	
Video Off After	[Standby]	
MODEM Use IRQ	[3]	
Suspend Mode	[1 Hour]	
HDD Power Down	[15 Min]	
Soft-Off by PWR-BTTN	[Instant-Off]	
CPU THRM-Throttling	[50.0%]	
Wake Up by PCI Card	[Enabled]	
PowerOn by Ring	[Enabled]	
Wake Up On LAN	[Enabled]	
USB KB Wake-Up FromS3	[Disabled]	
Resume by Alarm	[Disabled]	
Date (of Mongh) Alarm	0	
Time (hh:mm:ss) Alarm	0 : 0 : 0	
** Reload Global Timer Events **		
Primary IDE 0	[Disabled]	
Primary IDE 1	[Disabled]	
Secondary IDE 0	[Disabled]	
Secondary IDE 1	[Disabled]	
FDD, COM, LPT Port	[Disabled]	
PCI PIRQ [A-D]#	[Disabled]	

↑ ↓ ← → :Move Enter:Select +/-/PU/PD:Value F10:Save ESC:Exit F1:General Help
F5:Previous Values F6:Fail-Safe Defaults F7:Optimized Defaults

- **ACPI Suspend Type**

This item specifies the power saving modes for ACPI function. If your operating system supports ACPI, such as Windows 98SE, Windows ME and Windows 2000, you can choose to enter the Standby mode in S1 (POS) or S3 (STR) fashion through the setting of this field. Options are:

[S1 (POS)] The S1 sleep mode is a low power state. In this state, no system context is lost (CPU or chipset) and hardware maintains all system contexts.

[S3 (STR)] The S3 sleep mode is a lower power state where the information of system configuration and open applications/files is saved to main memory that remains powered while most other hardware components turn off to save energy. The information stored in memory will be used to restore the system when a “wake up” event occurs.

- **Power Management**

This option allows you to select the type (or degree) of power saving for Doze, Standby, and Suspend modes. The table below describes each power management mode:

Max Saving	It is maximum power savings, only available for SL CPUs. The inactivity period is 1 minute in each mode.
User Define	It sets each mode. Select time-out periods in the PM Timers section.
Min Saving	It is minimum power savings. The inactivity period is 1 hour in each mode (except the hard drive).
Disabled	Default value

- **PM Control by APM**

If Advanced Power Management (APM) is installed in your system, the selection of Yes will give better power savings. The default value is “Yes”.

No	The system BIOS will ignore APM when power is managing the system.
Yes	The System BIOS will wait for APM's prompt before it enters any PM mode (i.e., DOZE, STANDBY or SUSPEND). Note: <i>If APM is installed or there is a task running, even when the timer has timed out, the APM will not prompt the BIOS to put the system into any power saving mode!</i>



NOTE If APM is not installed, this option doesn't work.

- **Video Off Method**

This setting determines the manner in which the monitor is blanked.

V/H SYNC+Blank	It turns OFF vertical and horizontal synchronization ports and writes blanks to the video buffer.
DPMS	Select this option if your monitor supports the Display Power Management Signaling (DPMS) standard of the Video Electronics Standards Association (VESA). Use the supplied software for your video subsystem to select video power management values.
Blank Screen	The System only writes blanks to the video buffer.

- **Video Off After**

As the system changes from lesser to greater power-saving mode, select the mode in which you want the monitor to blank off. The default value is "Standby".

NA	The System BIOS will never turn off the screen.
Suspend	The screen will be off when the system is in SUSPEND mode.
Standby	The screen will be off when the system is in STANDBY mode.
Doze	The screen will be off when the system is in DOZE mode.



NOTE Green monitoring detects the V/H SYNC signals to turn off its electron gun.

- **Modem Use IRQ**

If you want an incoming call on a modem to automatically resume the system from a powersaving mode, use this item to specify the interrupt request line (IRQ) used by the modem. You might have to connect the fax/modem to the board Wake On Modem connector for working this feature.

- **Suspend Mode**

After a selected period of system inactivity (1 minute to 1 hour), all devices except the CPU shut off. The default value is "Disabled".

Disabled	The System will never enter the SUSPEND mode.
1/2/4/6/8/10/20/30/40 Min/1 Hr	It defines continuous idle time before the system entering the SUSPEND mode. If any item defined in (J) is enabled and active, the SUSPEND timer will be reloaded.

- **HDD Power Down**
If HDD activity is not detected for a specified length of time in this field, the hard disk drive will be powered down while other devices remain active.
- **Soft-Off by PWR-BTTN**
This option only works with systems using an ATX power supply. It also allows users to define which type of soft power OFF sequence the system will follow. The default value is “*Instant-Off*”.

Instant-Off	This option follows the conventional manner of system performance when turning the power to OFF. Instant-Off is a software power OFF sequence requiring the power supply button is switched to OFF.
Delay 4 Sec.	Upon the system's turning OFF through the power switch, this option will delay the complete system power OFF sequence approximately 4 seconds. Within this delay period, the system will temporarily enter into the Suspend Mode enabling you to restart the system at once.

- **CPU THRM-Throttling**
This item allows you to set up the CPU thermal throttling rate that you can reduce the CPU speed when it reaches the preset highest temperature.
- **Wake-Up by PCI card**
If enable this item, the system can automatically resume when the PCI Modem or PCI LAN card receives an incoming call.
- **Power On by Ring**
This option allows the system to resume or wake up upon detecting any ring signals coming from an installed modem. The default value is “*Enabled*”.
- **Wake Up On LAN**
When this option is enabled, a wake up event will awaken the

system from the power-down state.

- **Resume by Alarm**

If enable this item, the system can automatically resume after a fixed time in accordance with the system's RTC (realtime clock).

**** Reload Global Timer Events ****

Global Timer (power management) events can prevent the system from entering a power saving mode or can awaken the system from such a mode.

- **Primary/Secondary IDE 0/1**

Use this item to configure the IDE devices monitored by the system.

- **FDD, COM, LPT Port**

Use this item to configure the FDD, COM and LPT ports monitored by the system.

- **PCI PIRQ[A-D]#**

This item can be used to detect PCI device activities; if no activity, the system will enter the sleep mode.

Press <Esc> to return to the Main Menu page.

4.10 PnP/PCI Configuration Setup

This section describes the configuration of PCI (Personal Computer Interconnect) bus system, which allows I/O devices to operate at speeds close to the CPU speed while communicating with other important components. This section covers very technical items that only experienced users could change default settings.

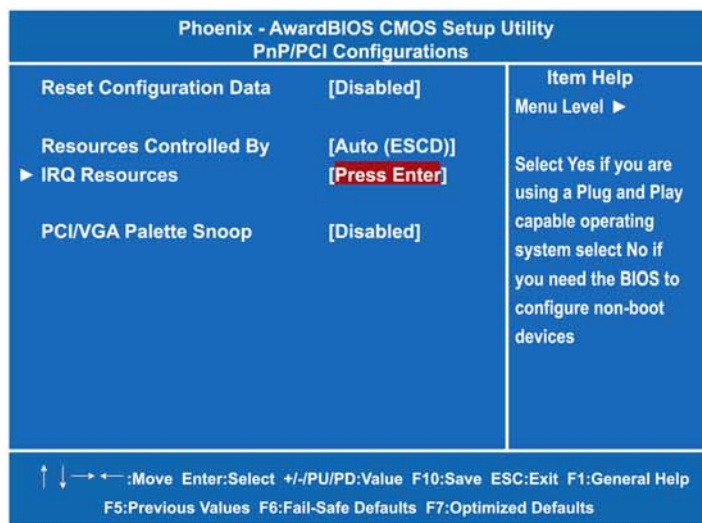

- Reset Configuration Data**
 Normally, you leave this item Disabled. Select Enabled to reset Extended System Configuration Data (ESCD) when you exit Setup or if installing a new add-on cause the system reconfiguration a serious conflict that the operating system can not boot. Options: Enabled, Disabled.
- Resources Controlled By**
 The Award Plug and Play BIOS can automatically configure all boot and Plug and Play-compatible devices. If you select Auto, all interrupt request (IRQ), DMA assignment, and Used DMA fields disappear, as the BIOS automatically assigns them. The default value is "Manual".
- IRQ Resources**
 When resources are controlled manually, assign each system interrupt to one of the following types in accordance with the type

of devices using the interrupt:

1. Legacy ISA Devices compliant with the original PC AT bus specification, requiring a specific interrupt (such as IRQ4 for serial port 1).
2. PCI/ISA PnP Devices compliant with the Plug and Play standard, whether designed for PCI or ISA bus architecture.

The default value is "*PCI/ISA PnP*".

- **PCI/VGA Palette Snoop**

Some non-standard VGA display cards may not show colors properly. This item allows you to set whether MPEG ISA/VESA VGA Cards can work with PCI/VGA or not. When enabled, a PCI/VGA can work with a MPEG ISA/VESA VGA card; when disabled, a PCI/VGA cannot work with a MPEG ISA/VESA Card.

Press <Esc> to return to the Main Menu page.

4.11 PC Health Status

This section supports hardware monitoring that lets you monitor those parameters for critical voltages, temperatures and fan speed of the board.

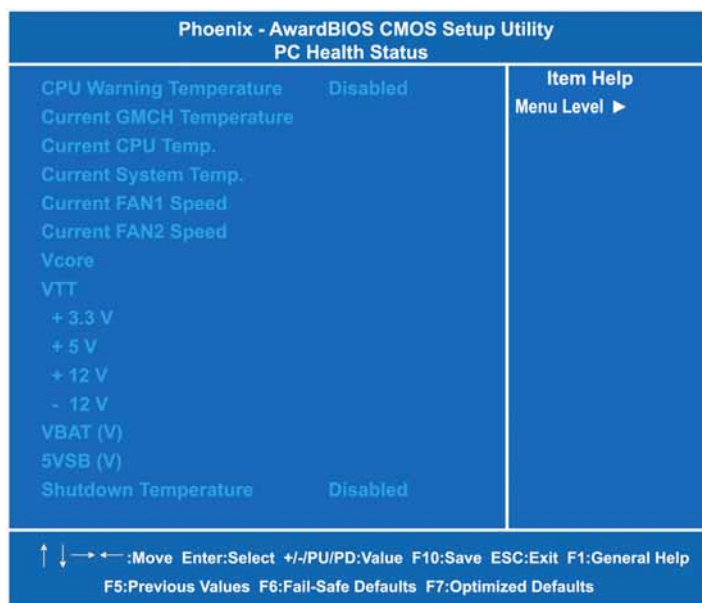

- **Current GMCH Temperature**
The current GMCH temperature will be automatically detected by the system.
- **Current CPU Temperature**
The current system CPU temperature will be automatically detected by the system.
- **Current SYSTEM Temperature**
Show you the current system1 temperature.
- **Current FAN1/FAN2 Speed**
Show you the current system fan1/fan2 temperature.
- **Vcore +3.3V/+5V/+12V/-12V/VBAT(V)/5VSB**
Show you the voltage of +3.3V/+5V/+12V/-12V.

Press <Esc> to return to the Main Menu page.

4.12 Frequency/Voltage Control

This section is to control the CPU frequency and Supply Voltage, DIMM OverVoltage and AGP voltage.

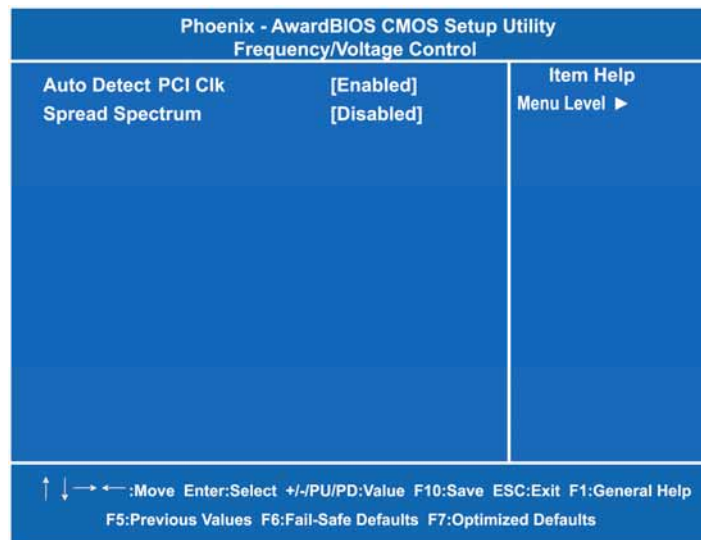

- **Auto Detect PCI Clk**
The enabled item can automatically disable the clock source for a PCI slot without a module, to reduce EMI (ElectroMagnetic Interference).
- **Spread Spectrum**
If spread spectrum is enabled, EMI (ElectroMagnetic Interference) generated by the system can be significantly reduced.

Press <Esc> to return to the Main Menu page.

4.13 Load Fail-Safe Defaults

When you press <Enter> on this item, a confirmation dialog box pops out to show you such a message:

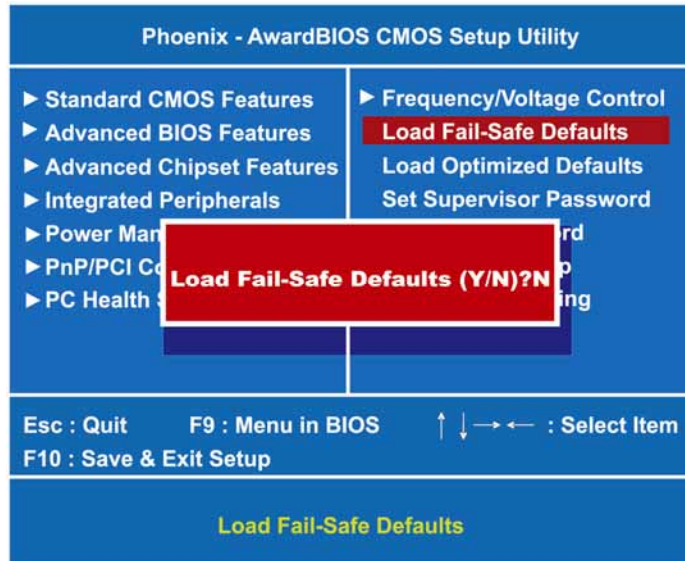

Please press “Y” to load default values that will be factory settings for accomplishing the optimal performance of system operations.

4.14 Load Optimized Defaults

This option allows you to load your system configuration with default values. These default settings are optimized to enable high performance features.

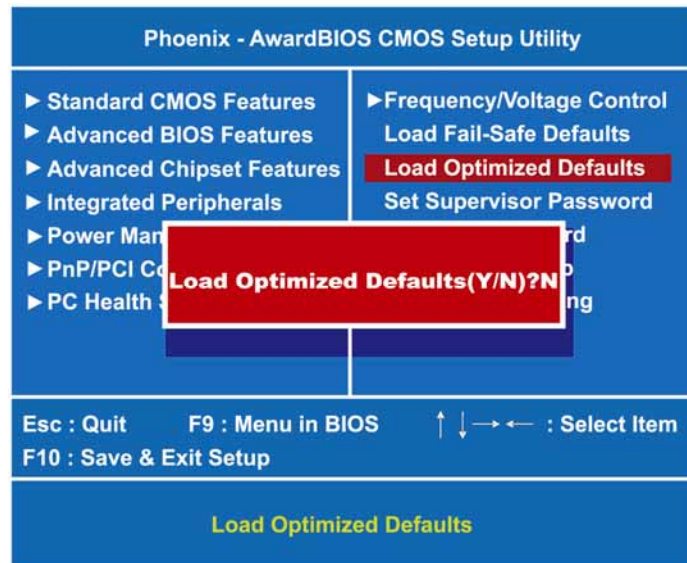

To load CMOS SRAM with SETUP default values, please enter “Y”. If not, please enter “N”.

4.15 Set Supervisor/User Password

You can set a supervisor or user password, or both of them. The differences between them are:

1. **Supervisor password:** You can enter and change the options on the setup menu.
2. **User password:** You can just enter, but have no right to change the options on the setup menu.

When you select this function, the following message will appear at the center of the screen to assist you in creating a password.

ENTER PASSWORD

Type a maximum eight-character password, and press <Enter>. This typed password will clear previously entered password from the CMOS memory. You will be asked to confirm this password. Type this password again and press <Enter>. You may also press <Esc> to abort this selection and not enter a password.

To disable the password, just press <Enter> when you are prompted to enter a password. A message will confirm the password is getting disabled. Once the password is disabled, the system will boot and you can enter Setup freely.

PASSWORD DISABLED

When a password is enabled, you have to type it every time you enter the Setup. It prevents any unauthorized persons from changing your system configuration.

Additionally, when a password is enabled, you can also require the BIOS to request a password every time the system reboots. This would prevent unauthorized use of your computer.

You decide when the password is required for the BIOS Features Setup Menu and its Security option. If the Security option is set to "System", the password is required during booting up and entry into the Setup; if it is set as "Setup", a prompt will only appear before entering the Setup.

4.16 Save & Exit Setup

This section allows you to determine whether or not to accept your modifications. Type "Y" to quit the setup utility and save all changes into the CMOS memory. Type "N" to bring you back to the Setup utility.

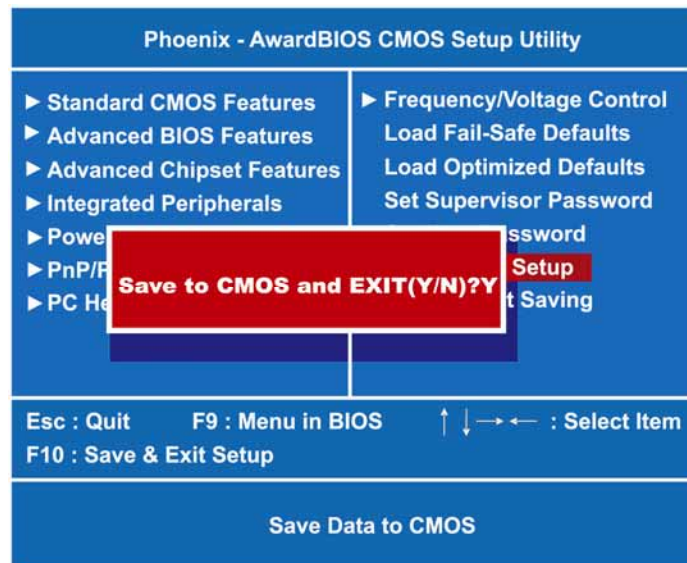

4.17 Exit Without Saving

Select this option to exit the Setup utility without saving changes you have made in this session. Type “Y”, and it will quit the Setup utility without saving your modifications. Type “N” to return to the Setup utility.

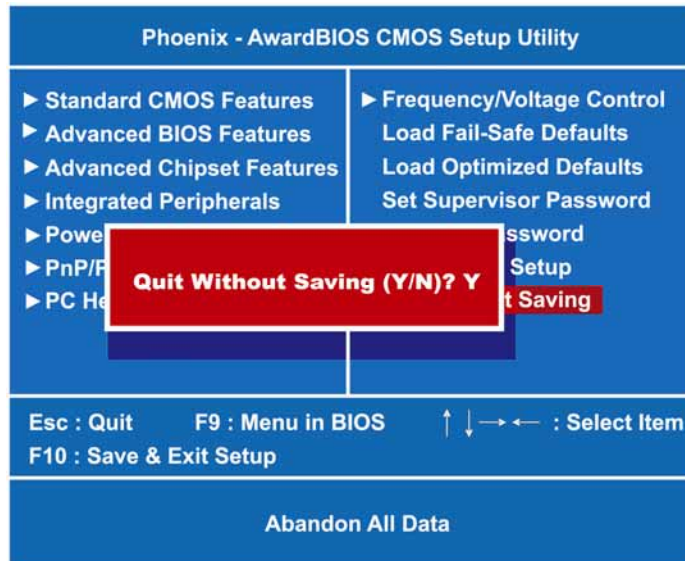

Appendix Watchdog Timer

Watchdog Timer Setting

The watchdog timer makes the system auto-reset while it stops to work for a period. The integrated watchdog timer can be setup as system reset mode by program.

Timeout Value Range

1 to 255

Second

Program Sample

Watchdog timer setup as system reset with 5 second of timeout

2E, 87	
2E, 87	
2E, 07	
2F, 00	Logical Device 0
2E, 29	Set WDT Funtion Enable
2F, A0	
2E, 07	
2F, 08	Logical Device 8
2E, 30	Activate
2F, 01	
2E, F3	Set Second
2F, N	N = 0 or 4
2E, F4	Set Value
2F, M	M = 00 ~ FF

Using the Watchdog Function

Start

↓

Un-Lock WDT : O 2E 87 ; Un-lock super I/O
O 2E 87 ; Un-lock super I/O

↓

Select Logic device : O 2E 07
O 2F 00

Set WDT Funtion : O 2E 29
O 2F A0

Select Logic device : O 2E 07
O 2F 08

Set Second or Minute : O 2E F3
O 2F N N=00 or 04(See below

table)

↓

Set base timer : O 2E F4
O 2F M=00,01,02,...FF(Hex) ,Value=0 to 255

↓

Activate WDT : O 2E 30
O 2F 01

↓

WDT counting

↓

re-set timer : O 2E F4
O 2F M ; M=00,01,02,...FF(See below table)

↓

IF No re-set timer : WDT time-out, generate RESET

IF to disable WDT : O 2E 30
O 2F 00 ; Can be disable at any time