

Q7300A,C,D,G Series 2000 Commercial Thermostat Subbases

INSTALLATION INSTRUCTIONS

APPLICATION

The Q7300 Thermostat Subbases are used with T7300 Thermostats to provide electronic control of commercial

24 Vac single or multistage heat pump or conventional heating and cooling systems. Select models have terminals for LEDs and remote temperature sensors. Refer to Table 1. All Q7300 Thermostat Subbases require a common wire to the supply power.

Table 1. Description of Q7300 Subbases.

Model	Applications	Thermostat Required	Maximum Stages ^a		Hookup Drawing
			Heat	Cool	
Q7300A	Conventional	T7300D, F	2	2	9-12
Q7300C	Heat Pump	T7300E, F	3	2	13-15
Q7300D	Heat Pump	T7300E, F	3	2	16
Q7300G	Conventional	T7300D, F	3	3	17

^a Depends on model.



RECYCLING NOTICE

If this control is replacing a control that contains mercury in a sealed tube, do not place your old control in the trash.

Contact your local waste management authority for instructions regarding recycling and the proper disposal of the old thermostat.

INSTALLATION

When Installing this Product...

1. Read these instructions carefully. Failure to follow the instructions can damage the product or cause a hazardous condition.
2. Check the ratings given in the instructions and on the product to make sure the product is suitable for your application.
3. Installer must be a trained, experienced service technician.
4. After completing installation, use these instructions to check out the product operation.

Location

Subbase without Remote-Mounted Temperature Sensor

Install the thermostat about 5 ft (1.5m) above the floor in an area with good air circulation at average temperature. See Fig. 1.

- Do not install the thermostat where it can be affected by:
- drafts, or dead spots behind doors and in corners.
 - hot or cold air from ducts.
 - radiant heat from sun or appliances.
 - concealed pipes and chimneys.
 - unheated (uncooled) areas such as an outside wall behind the thermostat.

Subbase with Remote-Mounted

Temperature Sensor(s)

If only the remote-mounted temperature sensor(s) is used to sense and control room temperature, then install the thermostat in an area that is accessible for setting and adjusting the temperature and settings.

If both the subbase and remote-mounted temperature sensor(s) are used to sense and control room temperature, then install the subbase about 5 ft above the floor in an area with good air circulation.



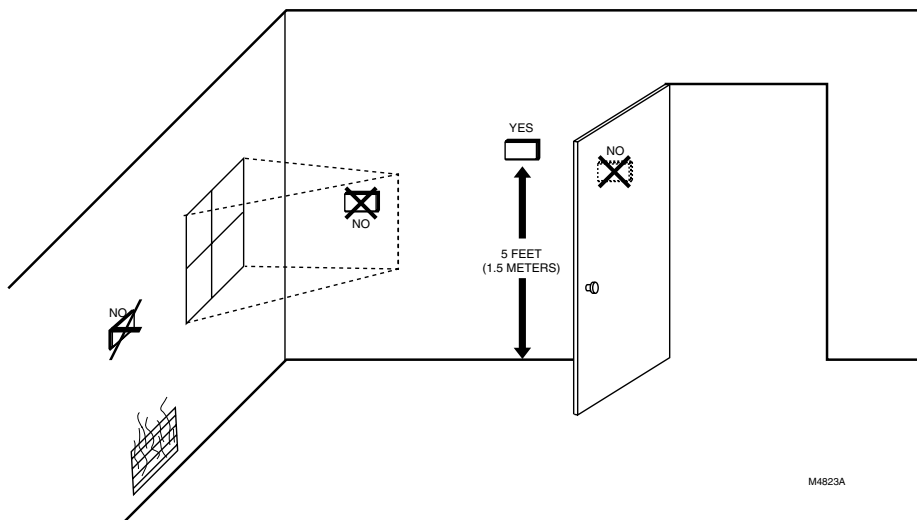

Fig. 1. Typical location of thermostat or remote-mounted sensor.

Install the remote-mounted sensor(s) about 5 ft (1.5m) above the floor in an area with good air circulation at average temperature. See Fig. 1.

Do not mount the sensor(s) where it can be affected by:

- drafts, or dead spots behind doors and in corners.
- hot or cold air from ducts.
- radiant heat from sun or appliances.
- concealed pipes and chimneys.
- unheated (uncooled) areas such as an outside wall behind the thermostat.

If more than one remote sensor are required, they must be arranged in a temperature averaging network consisting of two, three, four, five or nine sensors. See Fig. 2 through 6.

IMPORTANT

To avoid electrical interference, which can cause erratic performance, keep wiring runs as short as possible and do not run thermostat wires adjacent to the line voltage electrical distribution systems. Use shielded cable (Belden type 8762 or equivalent for 2-wire and Belden type 8772 or equivalent for 3-wire). The cable shield must be grounded only at the controlled equipment case.

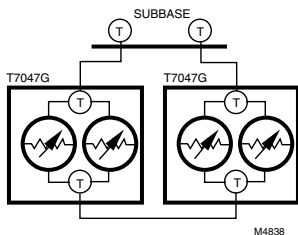

Fig. 2. Two T7047G Sensors providing temperature averaging network for T7300/Q7300 Thermostat/Subbase.

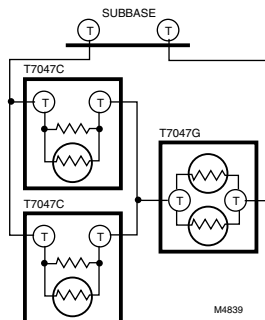

Fig. 3. Two T7047C Sensors and one T7047G Sensor providing temperature averaging network for T7300/Q7300 Thermostat/Subbase.

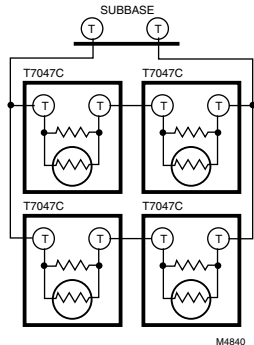

Fig. 4. Four T7047C Sensors providing temperature averaging network for T7300/Q7300 Thermostat/Subbase.

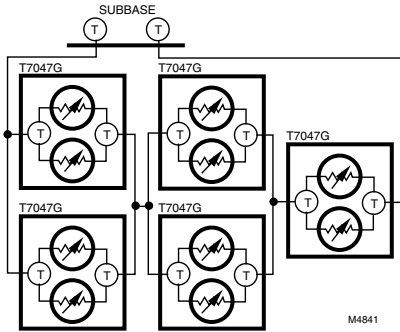

Fig. 5. Five T7047G Sensors providing temperature averaging network for T7300/Q7300 Thermostat/Subbase.

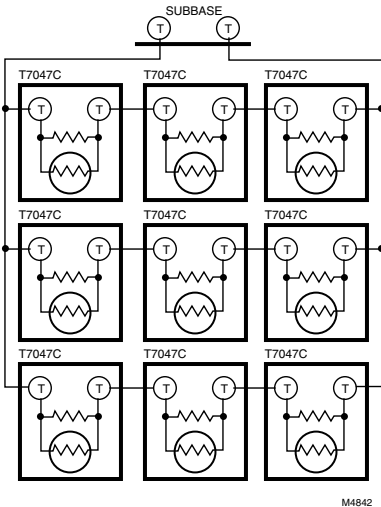

Fig. 6. Nine T7047C Sensors providing temperature averaging network for T7300/Q7300 Thermostat/Subbase.

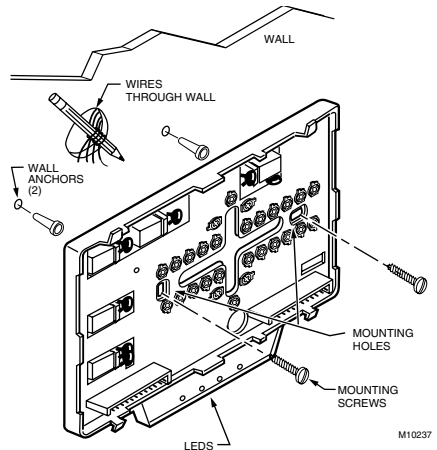

Fig. 7. Mounting the subbase.

WIRING SUBBASE

All wiring must comply with local electrical codes and ordinances. Follow equipment manufacturer wiring instructions when available. Refer to Fig. 9 through 17 for typical hookups. A letter code is located near each terminal for identification.



CAUTION

Disconnect power before wiring to prevent electrical shock or equipment damage.

- 1 Loosen the terminal screws on the subbase and connect the system wires. See Fig. 8.

IMPORTANT

Use 18-gauge, solid-conductor color-coded thermostat cable for proper wiring. If using 18-gauge stranded wire, no more than ten wires can be used. Do not use larger than 18-gauge wire.

- 2 Securely tighten each terminal screw.
- 3 Push excess wire back into the hole.
- 4 Plug the hole with nonflammable insulation to prevent drafts from affecting the thermostat.

Mounting Subbase

The subbase mounts horizontally on the wall or a 2 in. x 4 in. wiring box. Position the subbase horizontally on the wall or on a 2 in. x 4 in. wiring box.

- 1 Position and level the subbase or wallplate (for appearance only). The thermostat functions properly even when not level.
- 2 Use a pencil to mark the mounting holes. See Fig. 7.
- 3 Remove the subbase or wallplate from the wall and drill two 3/16 inch holes in the wall (if drywall) as marked. For firmer material such as plaster or wood, drill two 7/32 inch holes. Gently tap anchors (provided) into the drilled holes until flush with the wall.
- 4 Position the subbase over the holes, pulling wires through the wiring opening.
- 5 Loosely insert the mounting screws into the holes.
- 6 Tighten mounting screws.

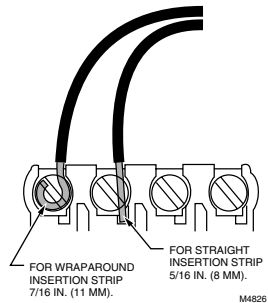

Fig. 8. Proper wiring technique.

Typical Wiring Hookups

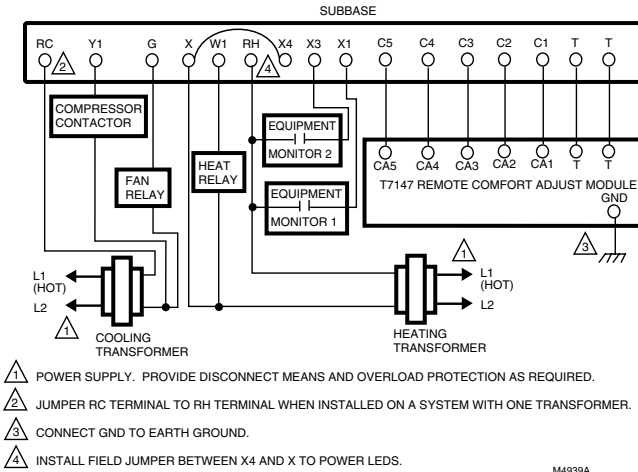

Fig. 9. Typical hookup of T7300D,F/Q7300A in one-stage heat and one-stage cool conventional system with two transformers.

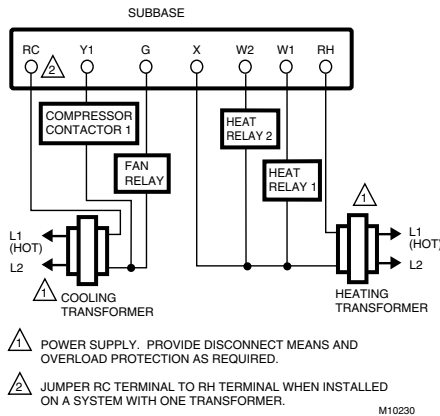

Fig. 10. Typical hookup of T7300D,F/Q7300A in two-stage heat and one-stage cool conventional system with two transformers.

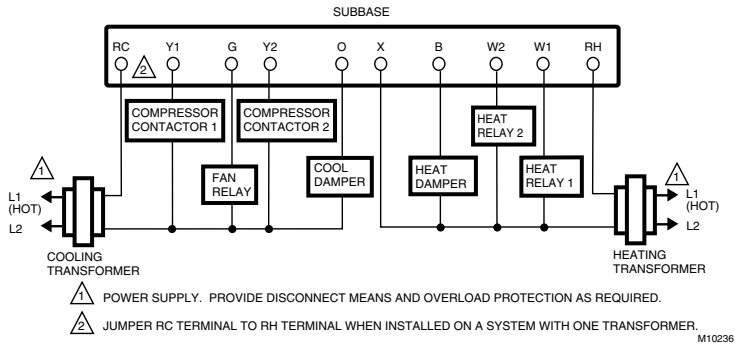

Fig. 11. Typical hookup of T7300D,F/Q7300A in two-stage heat and two-stage cool conventional system with two transformers.

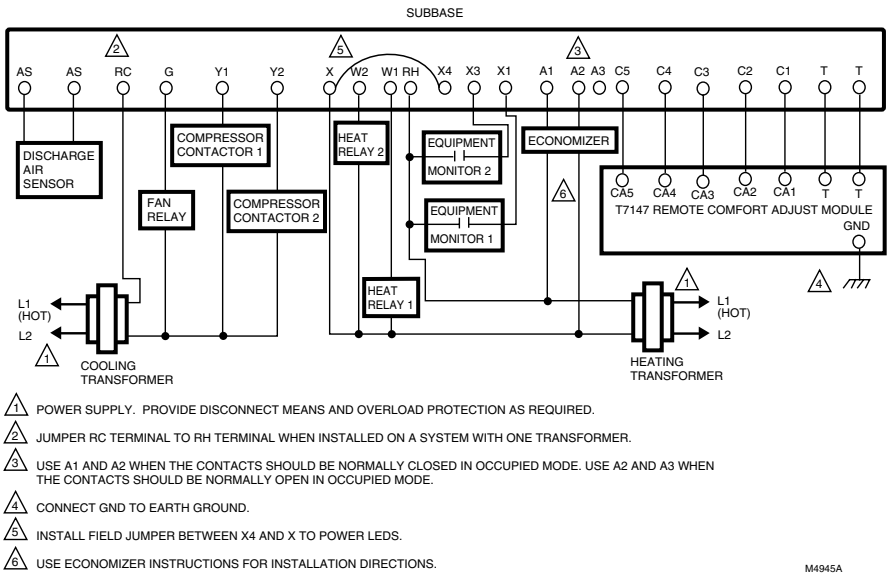

Fig. 12. Typical hookup of T7300D,F/Q7300A in two-stage heat and two-stage cool conventional system with two transformers.

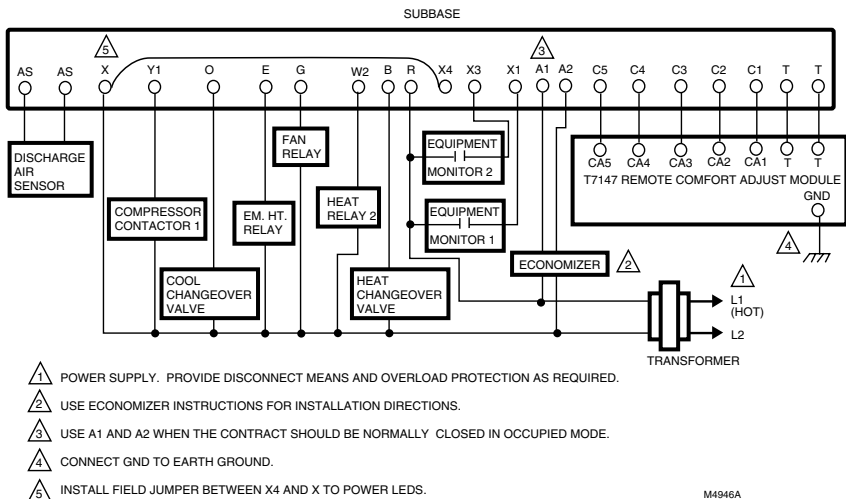

Fig. 13. Typical hookup of T7300E,F/Q7300C in two-stage heat and one-stage cool heat pump system.

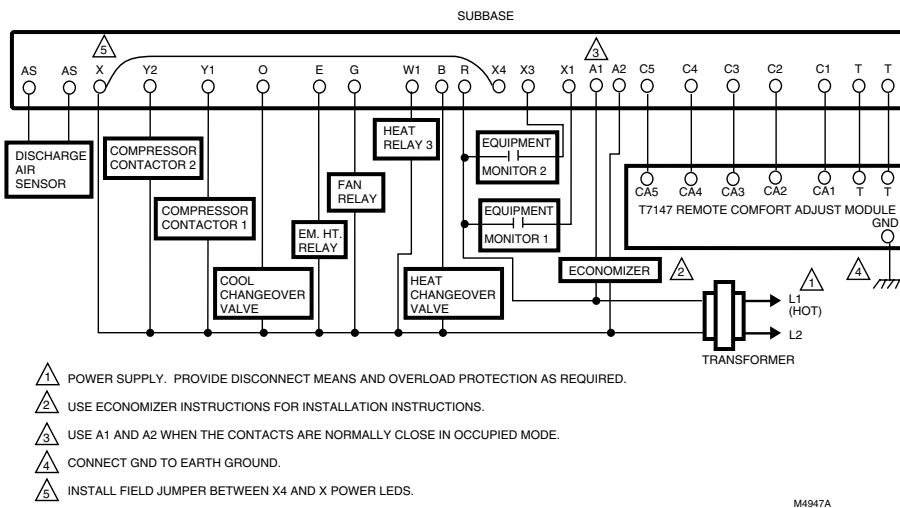

Fig. 14. Typical hookup of T7300E,F/Q7300C in three-stage heat and two-stage cool heat pump system.

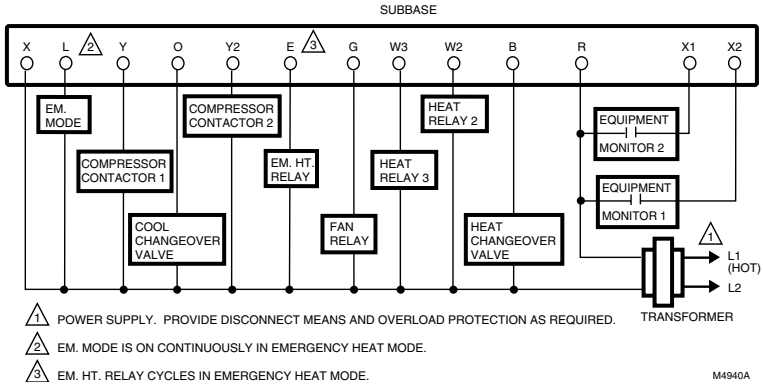

Fig. 15. Typical hookup of T7300E,F/Q7300C in three-stage heat and two-stage cool heat pump system.

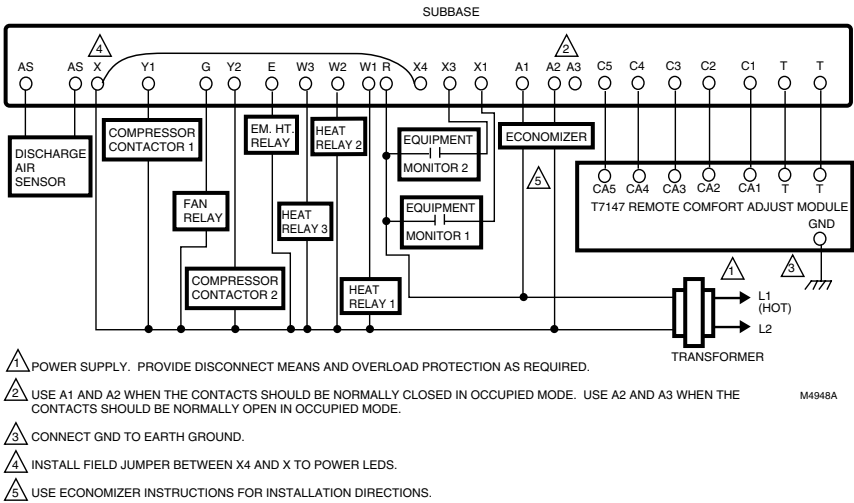

Fig. 16. Typical hookup of T7300E,F/Q7300D in three-stage heat and two-stage cool heat pump system.

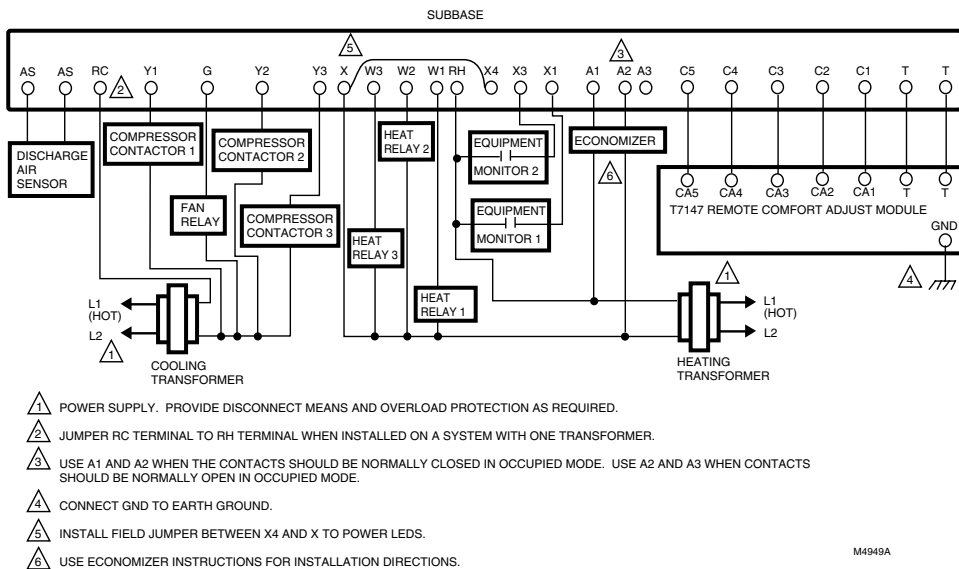

Fig. 17. Typical hookup of T7300D,F/Q7300G in three-stage heat and three-stage cool conventional system.

Mounting Thermostat on Subbase

Mount the thermostat on the subbase after the subbase is installed.

- 1 Engage tabs at the top of the thermostat and subbase. Fig. 18.
- 2 Press lower edge of case to latch.

NOTE: To remove the thermostat from the wall, first pull out at the bottom of the thermostat; then remove the top.

IMPORTANT

Refer to the thermostat installation instructions for Installer Setup, Settings, Installer Self-Test and Troubleshooting information.

A. ENGAGE TABS AT TOP OF THERMOSTAT AND SUBBASE OR WALLPLATE.

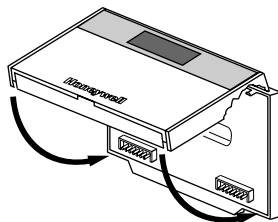

B. PRESS LOWER EDGE OF CASE TO LATCH.

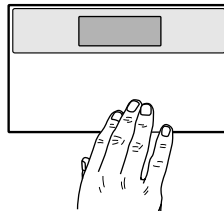

Fig. 18 Mounting thermostat on subbase.

Honeywell

Home and Building Control
 Honeywell Inc.
 Honeywell Plaza
 P.O. Box 524
 Minneapolis, MN 55408-0524

Home and Building Control
 Honeywell Limited-Honeywell Limitée
 155 Gordon Baker Road
 North York, Ontario
 M2H 2C9

