

# **DIN-A-MITE<sup>®</sup>** Style B

**Solid-State Power Controller**

## **User's Manual**



## **DIN-A-MITE Solid-State Power Controller**

Please consult this user's manual when you place your new DIN-A-MITE into service. It contains all the necessary information to mount and wire the product into the application. This manual also contains all user-pertinent specifications and semiconductor fusing recommendations. Refer to national and local electrical code safety guidelines whenever you install electrical equipment.

This DIN-A-MITE product is capable of switching up to 40 amps single-phase; 33 amps 3-phase, 2-leg; and 22 amps 3-phase, 3-leg at 600V~ (ac). (See the output rating curve in the specifications section of this manual.) The DIN-

A-MITE is electrically touch-safe, and includes DIN rail or standard back panel mounting. An optional shorted SCR (silicon controlled rectifier) alarm feature is available on specific models. UL<sup>®</sup> 508-listed, C-UL<sup>®</sup> and CE with filter.

The DIN-A-MITE solid-state power controller is designed and manufactured by Watlow in Winona, Minnesota.



1241 Bundy Boulevard, Winona, Minnesota USA 55987  
Phone: +1 (507) 454-5300, Fax: +1 (507) 452-4507 <http://www.watlow.com>

0600-0025-0005 Rev J

Made in the USA



June 2010

## General Specifications

### Operator Interface

- Command signal input and indication light
- Alarm output and indication light
- Input indicator LED

### Amperage Rating

- See the output rating curve chart on page 3.
- Ratings are into a resistive heater load.
- Maximum surge current for 16.6 milliseconds, 380 A peak
- Maximum I<sup>2</sup>t for fusing is 4000 A<sup>2</sup>s
- Latching current: 200mA minimum
- Holding current: 100mA minimum
- Off-state leakage 1mA at 25°C (77°F) maximum
- Power Dissipation: 1.2 watts per amp switched
- 200KA SCCR type 1 and 2 approved with the recommended fusing (see page 3)

### Line Voltage

- 24 to 48V~ (ac) units: 20.4V~ minimum to 53V~ maximum
- 120 to 240V~ (ac) units: 48V~ minimum to 265V~ maximum
- 277 to 600V~ (ac) units: 85V~ minimum to 660V~ maximum

### Control Mode, Zero-Cross

- Input Control Signal Type C: V~ (dc) input contactor. To increase service life, the cycle time should be less than 3 seconds.
- Input Control Signal Type K: V~ (ac) input contactor. To increase service life, the cycle time should be less than 3 seconds.
- Input Control Signal Type F: 4 to 20mA~ (dc) proportional variable time base control.

### Input Command Signal

#### • AC contactor

24V~ ±10%, 120V~ +10%/-25%, 240V~ (ac) +10%/-25% @ 25mA maximum per controlled leg

- Do not use the DIN-A-MITE Vac-input models with a temperature controller that includes an RC snubber circuit across its output. Remove the RC snubber circuit before placing the DIN-A-MITE into service.

#### • DC Contactor

4.5V~ to 32V~ (dc): maximum current @ 4.5V~ (dc) is 6mA per leg, plus 2mA per LED used.

#### • Loop powered linear current

4mA~ to 20mA~ (dc): loop-powered. Input Type F0 option only. (Requires current source with 6.2V~ (dc) available. No more than three DIN-A-MITE inputs connected in series)

### Linearity (Input Control Signal Type F)

- Full on point 19.5 to 19.9mA~ (dc), maximum voltage of 6.2V peak.
- ±5% input to output power accuracy, 0% to 100% of span (4.3 to 19.7mA).
- Temperature stability is less than 0.15%/°C change.

### Alarm (not available on multizone models)

#### Shorted SCR Alarm Option

- Alarm state when the input command signal off and a 10 A or more load current is detected by the current transformer (two turns required for 5A and three turns for 2.5A).

### Alarm output

- Energizes on alarm, non-latching
- Triac 24 to 240V~ (ac), external supply with a current rating of 300mA @ 25°C (77°F), 200mA @ 50°C (122°F), 100mA @ 80°C (176°F) and a holding current of 200µA with a latching current of 5mA typical.

### Agency Approvals

- CE with proper filter:
  - 2004/108/EC Electromagnetic Compatibility Directive EN 61326: Industrial Immunity Class A emissions
  - 2006/95/EC Low Voltage Directive EN 50178 Safety Requirements
- Installation category III, pollution degree 2
-  UL® 508 listed and C-UL®, File E73741

### Input Terminals

- Compression: Will accept 0.2 to 1.5 mm<sup>2</sup> (24 to 16 AWG) wire
- Torque to 0.5 Nm (4.4 in-lb) maximum with a 3.5 mm (1/8 in) blade screwdriver
- Wire strip length 5.5 mm (0.22 in)

### Line and Load Terminals

- Compression: Will accept 0.75 to 10 mm<sup>2</sup> (18 to 8 AWG) wire
- Torque to 1.4 Nm (12 in-lb) with a 6.4 mm (1/4 in) blade screwdriver, or a Type 1A #2 Pozi driver.
- Retorque after 48 hours to minimize wire cold flow.
- Retorque line and load terminals every 3 to 6 months.
- Wire strip length 6.35 mm (0.25 in)
- Ground terminal use spade terminal for No. 8 screw, with upturned lugs.

### Operating Environment

- See the output rating curve.
- 0 to 90% RH (relative humidity), non-condensing
- Storage temperature: -40 to +85°C (-40 to 185°F)
- Insulation only tested to 3,000 meters

### DIN Rail Mount

- DIN EN 50022, 35 mm by 7.5 mm
- Minimum clipping distance: 34.8 mm (1.37 in)
- Maximum clipping distance: 35.3 mm (1.39 in)

### Note: Mount cooling fins vertically.

### Back Panel Mount

- Four mounting holes M4 (No. 8) fastener

### Weight

- 0.7 kg (1.6 lb)

### Specifications are subject to change without notice.

## DIN-A-MITE B Ordering Information

To order, complete the code number on the right with the information below:

**Style B** = solid-state power controller

**D B**

**Phase** \_\_\_\_\_

- 1 = single-phase, 1 controlled leg
- 2 = 3-phase, 2 controlled legs
- 3 = 3-phase, 3 controlled legs (for 4-wire wye)
- 8 = 2 independent zones (input control C or K)
- 9 = 3 independent zones (input control C or K)

**Cooling and Current Rating Per Pole** \_\_\_\_\_

- 0 = Natural convection standard DIN rail or panel heatsink

**Line and Load Voltage** \_\_\_\_\_

- 02 = 24 to 48V~ (ac)
- 24 = 120 to 240V~ (ac)
- 60 = 277 to 600V~ (ac)

**Input Control Signal** \_\_\_\_\_

- C0 = 4.5 to 32V= (dc) contactor
- K1 = 22 to 26V~ contactor
- K2 = 100 to 120V~ contactor
- K3 = 200 to 240V~ contactor
- F0 = Proportional 4 to 20mA

**Alarm** \_\_\_\_\_

- 0 = No alarm
- S = Shorted SCR Alarm (not available with phase options 8 or 9 above)

**User Manual Language** \_\_\_\_\_

- 0 = English
- 1 = German
- 2 = Spanish
- 3 = French

**Custom Part Numbers** \_\_\_\_\_

- 00 = Standard part
- XX = Any letter or number, custom options, labeling, etc.

**Note:**

- Recommended fusing options to meet 200KA SCCR, type 1 and 2 approved. All other fuse and SCR combinations are defaulted to 5KA SCCR per UL508A and NEC guidelines.

### Recommended Semiconductor Fuse and Fuse Holder

Fuse	Watlow	Bussmann	Bussmann Combination
20 A	17-8020	FWP20A10F	DFJ20
30 A	17-8030	FWP30A14F	DFJ30
40 A	17-8040	FWP40A14F	DFJ40
50 A	17-8050	FWP50A14F	DFJ50
Holder			
20 A	17-5110	17-5110	CH30J1i
30 A	17-5114	17-5114	CH30J1i
40 A	17-5114	17-5114	CH60J1i
50 A	17-5114	17-5114	CH60J1i

### Current Rating Table

Model	Current at 50°C (122°F)
DB10	35A
DB20, DB80	25A
DB30, DB90	17A

### Output Rating Curves

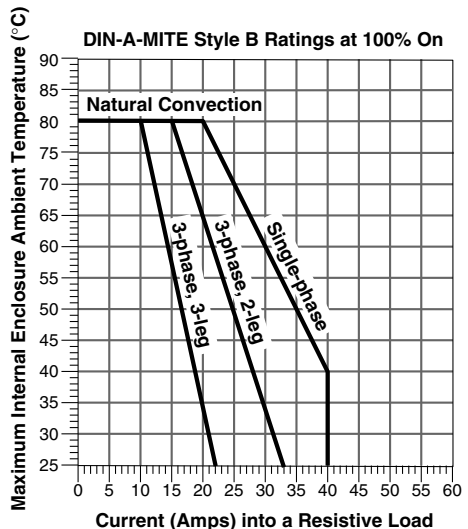

## Mount

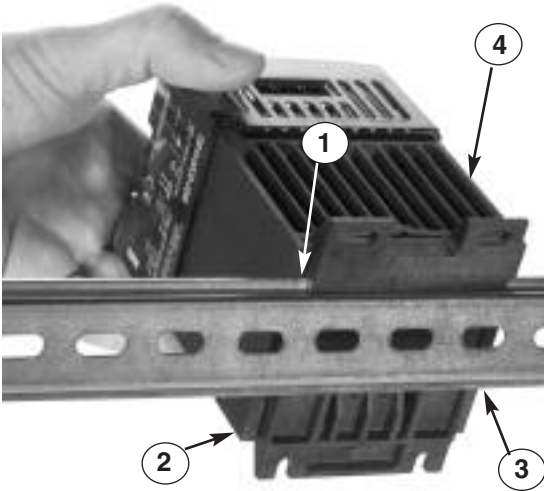

1. Push the unit in and down to catch the rail hook on top of the rail.
2. Rotate the bottom of the unit in toward the rail.
3. The rail clasp will audibly “snap” into place. If the DIN-A-MITE does not snap into place, check to see if the rail is bent.
4. Mount the cooling fins vertically.

## Dismount

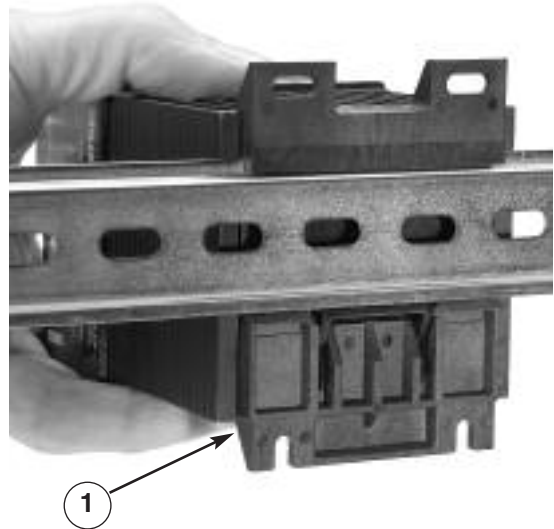

1. Press down on the release tab while rotating the unit up and away from the rail.

## Unit Dimensions - Rail-Mounted



**WARNING:**  
Only authorized and qualified personnel should be allowed to install and perform preventive and corrective maintenance on this unit. Failure to follow this guideline could result in damage to equipment, and personal injury or death.



**WARNING:**  
Hot surface, do not touch the heat sink. Failure to follow this guideline could result in personal injury.



Mount the cooling fins vertically. ↑

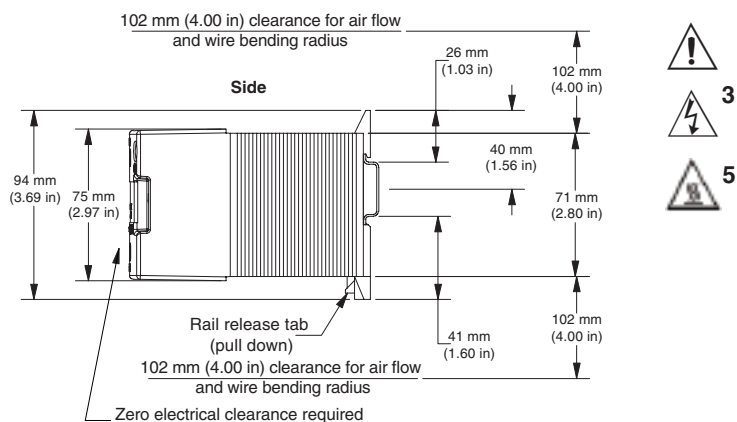
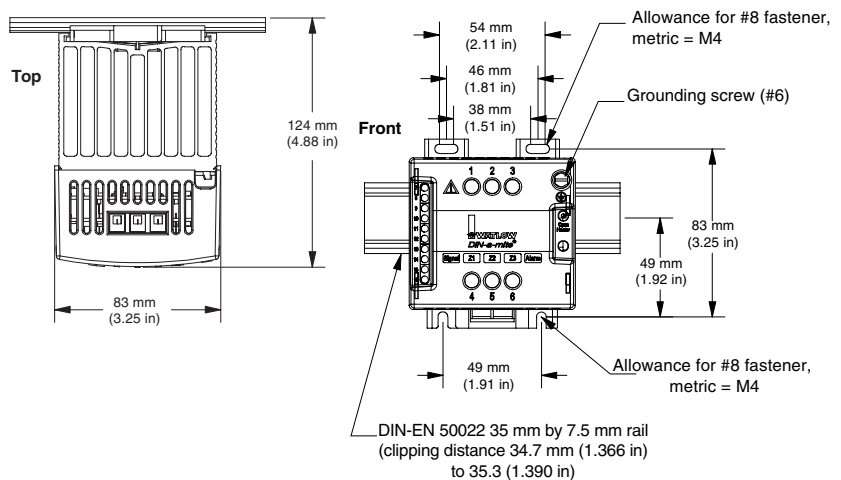



**WARNING:** Use National Electric (NEC) or other country-specific standard wiring practices to install and operate the DIN-A-MITE. Failure to do so may result in damage to equipment and property, and/or injury or loss of life.



**WARNING:** Wiring examples show L2 in phase-to-phase, 200V~ (ac) and above configuration. In phase-to-neutral, 100 V~ (ac) and above applications, L2 is neutral and must not be fused or switched. Failure to follow this guideline could result in personal injury or death.



**WARNING:** Only authorized and qualified personnel should be allowed to install and perform preventive and corrective maintenance on this unit. Failure to follow this guideline could result in damage to equipment, and personal injury or death.



**WARNING:** Do not use the DIN-A-MITE Vac-input models with a temperature controller that includes an RC snubber circuit across its output. Remove the RC snubber circuit before placing the DIN-A-MITE into service.

**NOTE:** Shorted SCR (silicon-controlled rectifier) alarm option not available with multizone input option.

## Input Wiring

(For models DB [1, 2, 3] \_ \_ \_ [C, F, K] \_ \_ \_ \_)

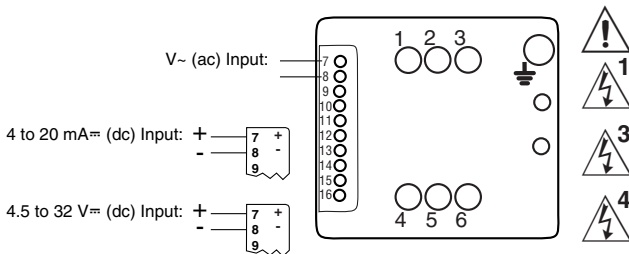

## Multizone Input Wiring

(For models DB [8, 9] \_ \_ \_ [C, K] \_ \_ \_ \_)

### 2-zone

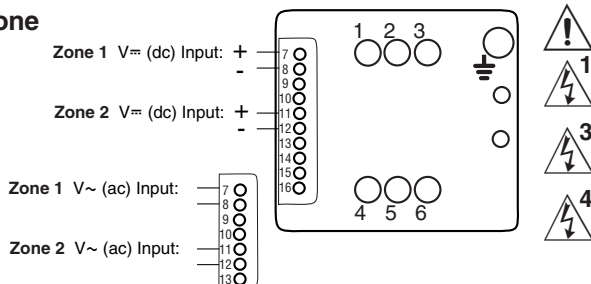

### 3-zone

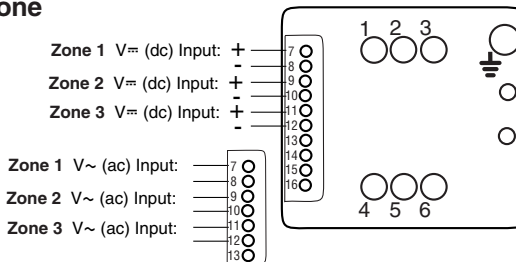

## Multizone Output Wiring

(For models DB [8, 9] \_ \_ \_ [C, K] \_ \_ \_ \_)

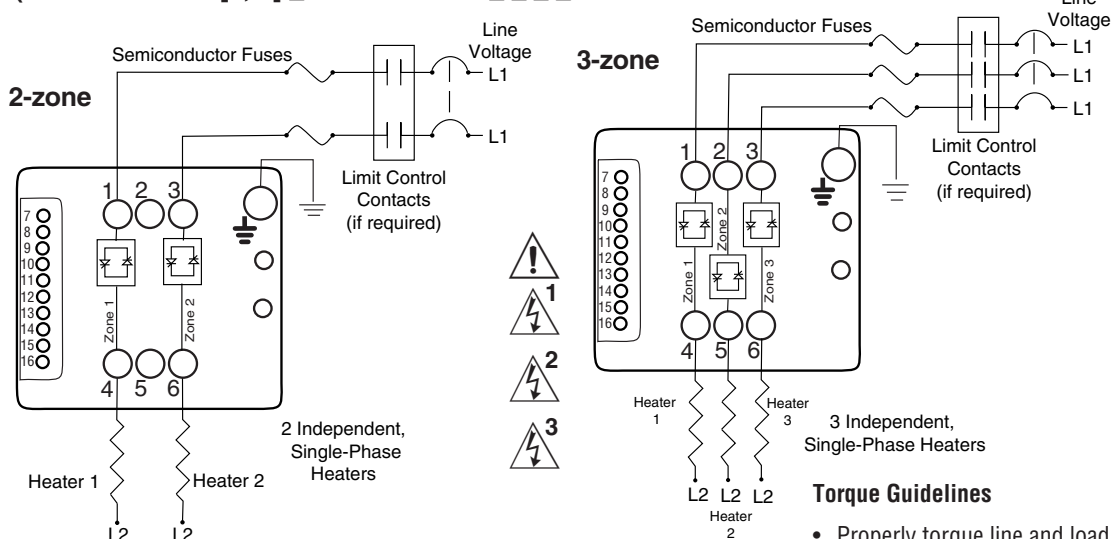

**NOTE:** Independent loads do not have to be on the same phase.

**NOTE:** Do not use terminals 2 and 5 on DB8 when connecting line power and heater load.

**NOTE:** Use a grounding conductor terminal plate (fork terminal) having upturned lugs or the equivalent to hold the wire in position. Maximum 6 mm<sup>2</sup> (10 AWG) wire.

### Torque Guidelines

- Properly torque line and load terminals to 1.4 Nm (12 in-lb).
- Retorque after 48 hours to minimize wire cold flow.
- Retorque line and load terminals every 3 to 6 months.



**WARNING:**  
Use National Electric (NEC) or other country-specific standard wiring practices to install and operate the DIN-A-MITE. Failure to do so may result in damage to equipment and property, and/or injury or loss of life.



**WARNING:**  
Wiring examples show L2 in phase-to-phase, 200V~ (ac) and above configuration. In phase-to-neutral, 100V~ (ac) and above applications, L2 is neutral and must not be fused or switched. Failure to follow this guideline could result in personal injury or death.



**WARNING:**  
Only authorized and qualified personnel should be allowed to install and perform preventive and corrective maintenance on this unit. Failure to follow this guideline could result in damage to equipment, and personal injury or death.

**NOTE:**  
Use a grounding conductor terminal plate (fork terminal) having upturned lugs or the equivalent to hold the wire in position. Maximum 6 mm<sup>2</sup> (10 AWG) wire.

#### Torque Guidelines

- Properly torque line and load terminals to 1.4 Nm (12 in-lb).
- Retorque after 48 hours to minimize wire cold flow.
- Retorque line and load terminals every 3 to 6 months.

### Single-phase Output

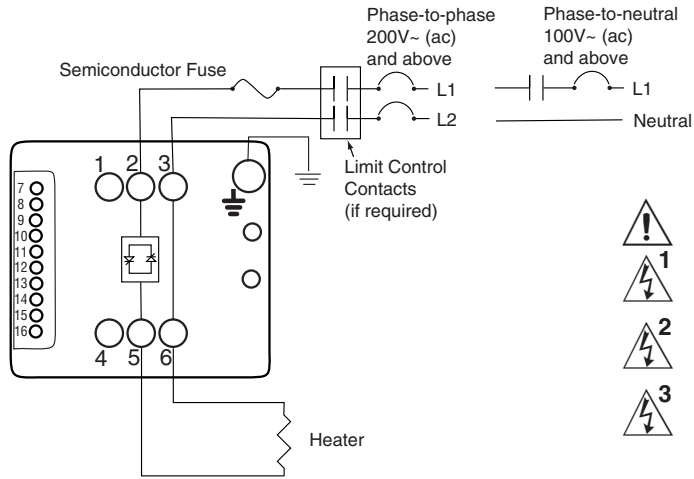

### 3-phase, 2-leg Output

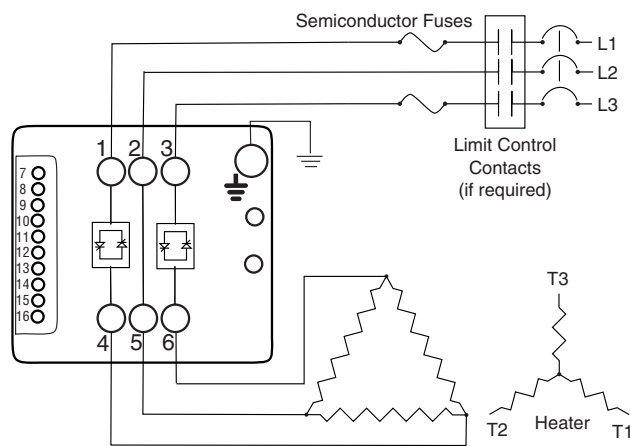

### 3-phase, 3-leg Output

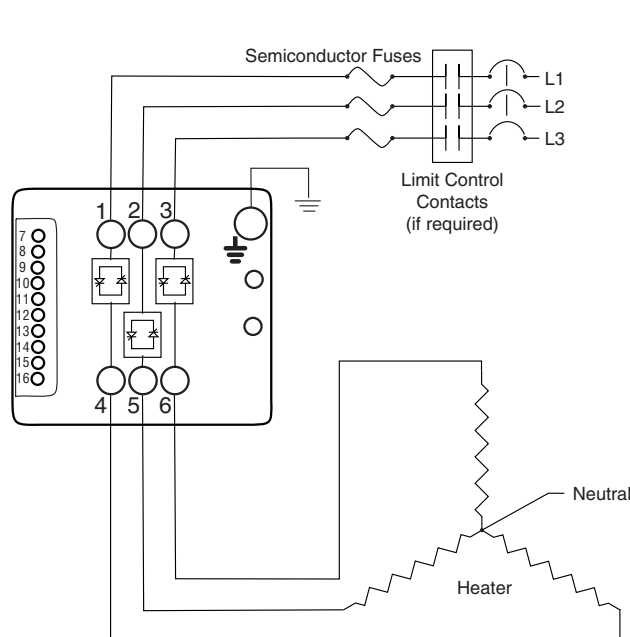



**WARNING:**  
Use National Electric (NEC) or other country-specific standard wiring practices to install and operate the DIN-A-MITE. Failure to do so may result in damage to equipment and property, and/or injury or loss of life.

**NOTE:** If you plan to wire multiple DIN-A-MITE alarm outputs, you need to include an intermediate relay for each DIN-A-MITE used.



**WARNING:**  
Wiring examples show L2 in phase-to-phase, 200 V~ (ac) and above configuration. In phase-to-neutral, 100V~ (ac) and above applications, L2 is neutral and must not be fused or switched. Failure to follow this guideline could result in personal injury or death.



**WARNING:**  
Only authorized and qualified personnel should be allowed to install and perform preventive and corrective maintenance on this unit. Failure to follow this guideline could result in damage to equipment, and personal injury or death.

**Torque Guidelines**

- Properly torque line and load terminals to 1.4 Nm (12 in-lb).
- Retorque after 48 hours to minimize wire cold flow.
- Retorque line and load terminals every 3 to 6 months.

**Current Transformer and Alarm Wiring**

DB - - - - - S

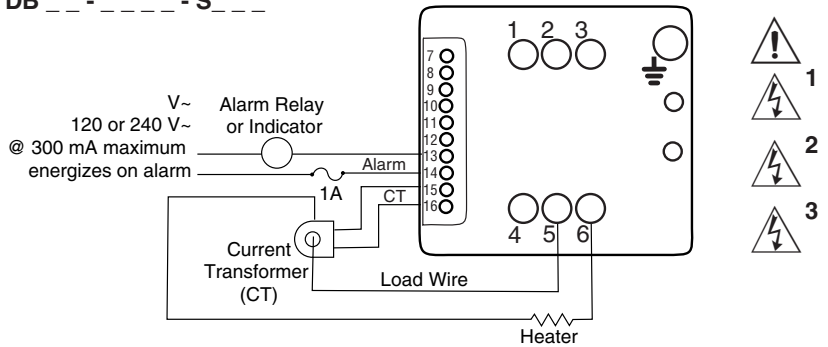

The Watlow DIN-A-MITE alarm option provides a common alarm output for shorted SCR conditions. **This is a non-latching alarm.**

A shorted SCR alarm is detected when there is no command signal and a load current is detected. The alarm output is then energized.

Load Current	Passes of Load Wire Through the Current Transformer
5 to 9A	2
10 to 30A	1

**3-phase, 2-leg Current Transformer Wiring**

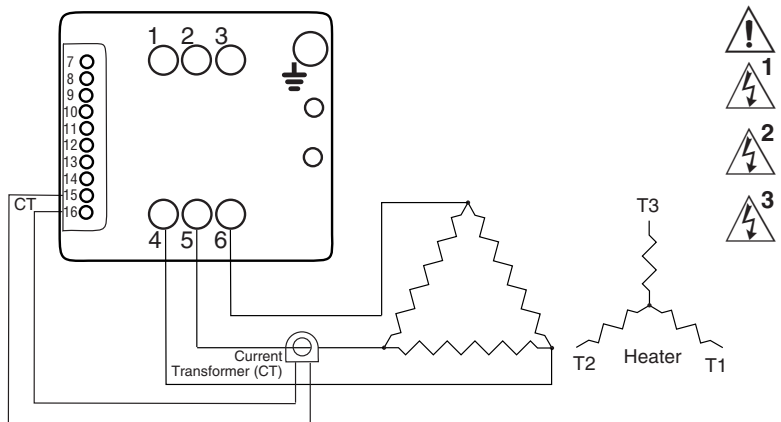

**3-phase, 3-leg Current Transformer Wiring**

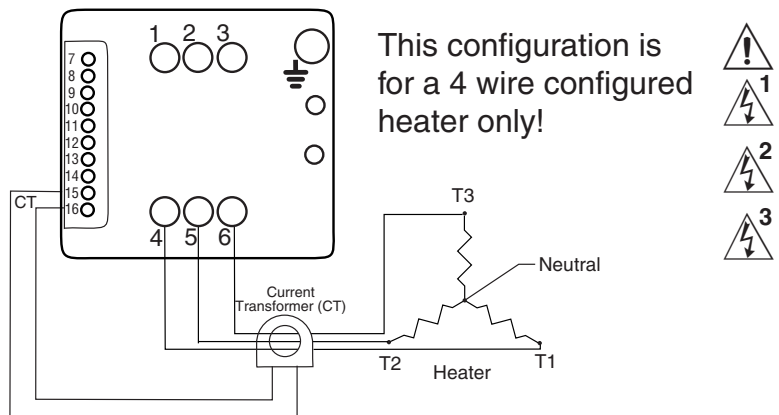

This configuration is for a 4 wire configured heater only!

## System Wiring Example



1

### WARNING:

Use National Electric (NEC) or other country-specific standard wiring practices to install and operate the DIN-A-MITE. Failure to do so may result in damage to equipment and property, and/or injury or loss of life.



2

### WARNING:

Wiring examples show L2 in phase-to-phase, 200 V~ (ac) and above configuration. In phase-to-neutral, 100 V~ (ac) and above applications, L2 is neutral and must not be fused or switched. Failure to follow this guideline could result in personal injury or death.



3

### WARNING:

Only authorized and qualified personnel should be allowed to install and perform preventive and corrective maintenance on this unit. Failure to follow this guideline could result in damage to equipment, and personal injury or death.

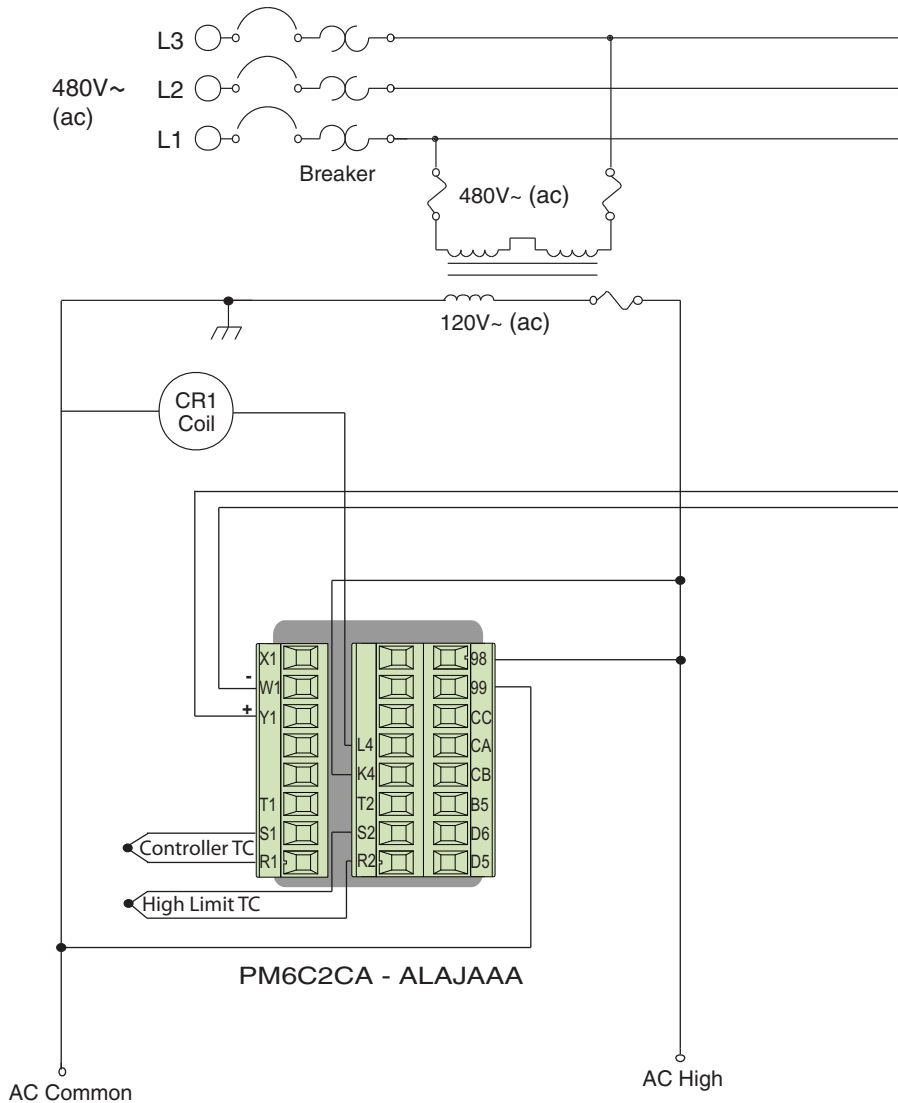

CR1 = High-Limit Contactor

### Latching Alarm Option

(models DB \_ \_ - \_ \_ \_ \_ - S \_ \_ \_ )

### Alternative Latching Alarm Circuit

If there is a need for a latching alarm, the DIN-A-MITE alarm circuit could be used as shown at right in the latching alarm example. If the DIN-A-MITE triac alarm output energizes, it will energize the RY1 (external alarm relay) mechanical relay coil. Once the RY1 coil is energized it will latch on (via the RY1A normally open contact) until the power to the relay is removed. You could cycle the power via a reset switch. The RY1B contact can be used for alarm signaling.

**NOTE:** If you plan to wire multiple DIN-A-MITE alarm outputs, you need to include an intermediate relay for each DIN-A-MITE used.

### Torque Guidelines

- Properly torque line and load terminals to 1.4 Nm (12 in-lb).
- Retorque after 48 hours to minimize wire cold flow.
- Retorque line and load terminals every 3 to 6 months.



**Non-latching Alarm Option**  
(models DB\_\_ - \_\_\_\_\_ - S\_\_\_\_)

**Shorted SCR (silicon-controlled rectifier) Alarm**  
**Non-latching Operation**

The shorted SCR detector compares the input command signal and actual load current. If load current is present without an input signal then the shorted SCR alarm will energize the alarm triac output. This is a non-latching alarm. This output can be used to drive various indication devices, such as a coil, light, buzzer, etc. See the alternative latching circuit section below.

**NOTE:**  
Use a grounding conductor terminal plate (fork terminal) having upturned lugs or the equivalent to hold the wire in position. Maximum 6 mm<sup>2</sup> (10 AWG) wire.

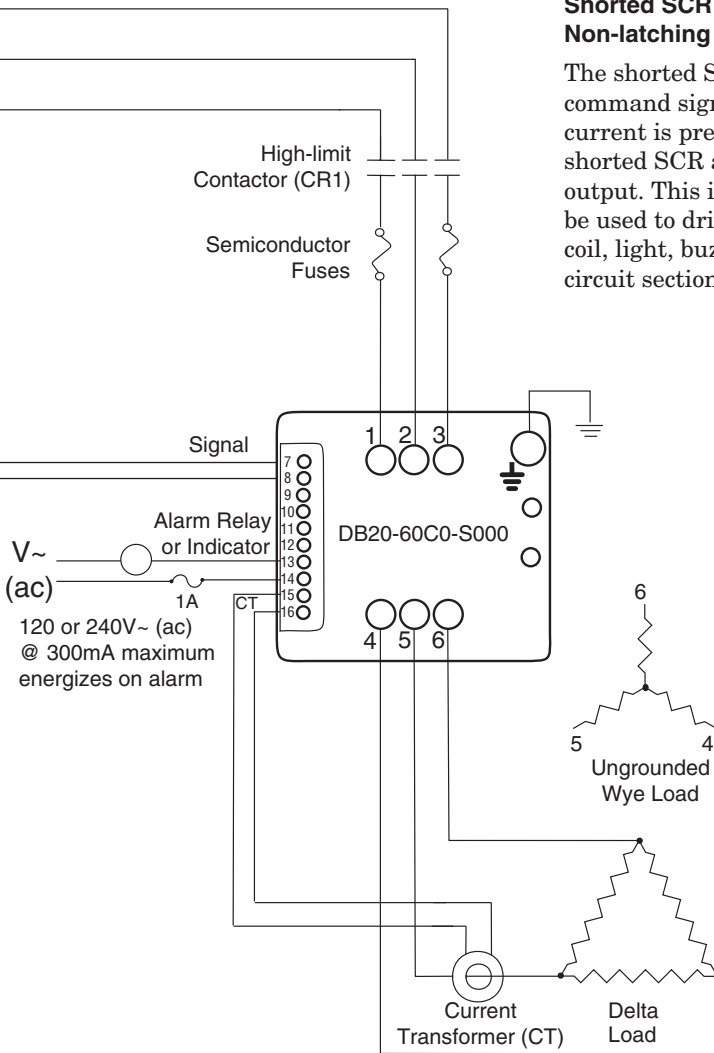

**NOTE:** The current transformer must be in the center uncontrolled leg on a 2-leg DIN-A-MITE.

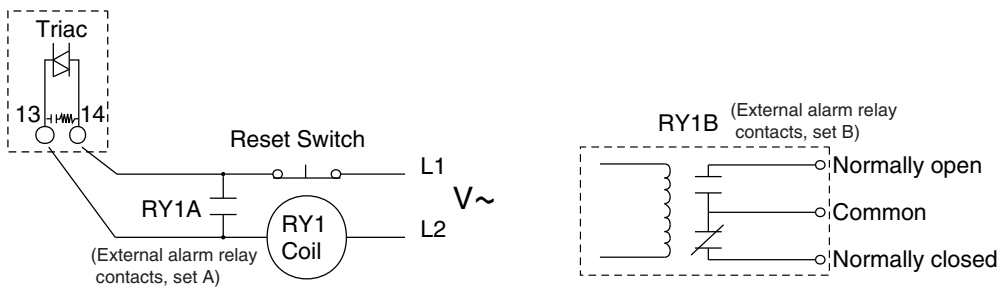

**Latching Alarm Relay Circuit**

# DIN-A-MITE<sup>®</sup> “B” Power Controller

WATLOW

since 1996.

1241 Bundy Blvd.

Winona, MN 55987 USA

an ISO 9001 approved facility

Declares that the following product:

Designation: DIN-A-MITE<sup>®</sup> “B” Power Control  
Model Numbers: DB (1, 2, 3, 4, 8 or 9) 0 – (02, 24 or 60)(CX, FX, K1, K2, K3) – (0 or S)(followed by any 3 letters or numbers) (where X = any number 0-9)  
Classification: Power Control, Installation Category III, Pollution degree 2, IP20  
Rated Voltage: 24 to 600 V~ (ac), 50/60 Hz

Meets the essential requirements of the following European Union Directives by using the relevant standards show below to indicate compliance.

## 2004/108/EC Electromagnetic Compatibility Directive

<b>EN 61326-1: 2005</b>	<b>Electrical equipment for measurement, control and laboratory use – EMC requirements (Industrial Immunity, Class A<sup>1,2,4</sup> Emissions) <i>Not for use in a Class B environment without additional filtering.</i></b>
EN 61000-4-2:1996 +A1,A2	Electrostatic Discharge Immunity
EN 61000-4-3:2006	Radiated Field Immunity 10V/m 80 MHz- 1GHz, 3V/m 1.4GHz-2.7GHz
EN 61000-4-4:1995	Electrical Fast-Transient / Burst Immunity
EN 61000-4-5:1995 +A1,A2	Surge Immunity
EN 61000-4-6:1996 +A1,A2,A3	Conducted Immunity
EN 61000-4-11:2004	Voltage Dips, Short Interruptions and Voltage Variations
EN 61000-3-2:2005	Harmonic Current Emissions
EN 61000-3-3:2005	Voltage Fluctuations and Flicker <sup>3</sup> ≤ 16A
EN 61000-3-11:2001	Voltage Fluctuations and Flicker ≤ 75A with conditional connection

### NOTES

<sup>1</sup>Use of an external filter is required to comply with conducted emissions limits. See note 4 below.

<sup>2</sup>A Line Impedance Stabilization Network (LISN) was used for conducted emissions measurements.

<sup>3</sup>To comply with flicker requirements, command signal models F0 and F1 will require a reduced source impedance. Cycle time on ON/OFF models CX and K1, K2, K3 may need to be up to 175 seconds at 16A or have a reduced source impedance.

## 2006/95/EC Low-Voltage Directive

**EN 50178:1997**                      **Electronic equipment for use in power installations.**

Per 2002/96/EC W.E.E Directive  Please Recycle Properly.

**These devices contain lead solder and are not RoHS compliant.  
They are a Control Device and fall outside the scope of 2002/95/EC Directive.**

<sup>4</sup>Required External EMI Filters for DIN-A-MITE with More Than 6 Amp Loads

Raymond D. Feller III  
Name of Authorized Representative  
General Manager  
Title of Authorized Representative

Winona, Minnesota, USA  
Place of Issue  
January 2009  
Date of Issue

  
Signature of Authorized Representative

## Required External EMI Filters for DIN-A-MITE with More than 6 A Loads

An external EMI filter must be used in conjunction with the DIN-A-MITE for loads in excess of six amperes (6 A) at 150 to 250 kHz. Without a filter applied, the DIN-A-MITE does not comply with the conducted emissions standard for loads above 6 A at 150 to 250 KHz.

Watlow has verified that two types of filters will suppress electromagnetic interference (EMI) created by the DIN-A-MITE power controller to within the CE requirements.

A tank filter supplied by Crydom or Watlow, installed across the power lines, suppresses EMI on the power lines. See Figures 1 and 2.

See Table 1 for the correct filter.

**⚠ WARNING:**

The isolating and tank filters specified may suppress desirable communications carried on power lines in the 150 to 250 kHz region. The filters may suppress carrier current such as that used for infant monitors and medical alert systems. Verify that suppressed carrier current or other desirable communications on power lines creates no hazard to people or property. Failure to observe this warning could result in damage to property, and injury or death for personnel.

**⚡ WARNING:**

All filter installation and wiring must be performed by qualified personnel, and conform to local and national electrical codes. Failure to observe this warning could result in damage to property, and injury or death for personnel.

Description	Crydom Filter	Watlow Filter
Single-phase, 230V~ (ac)	1F25	14-0019
Three-phase, 440V~ (ac)	3F20	

Table 1— DIN-A-MITE EMI Filters.

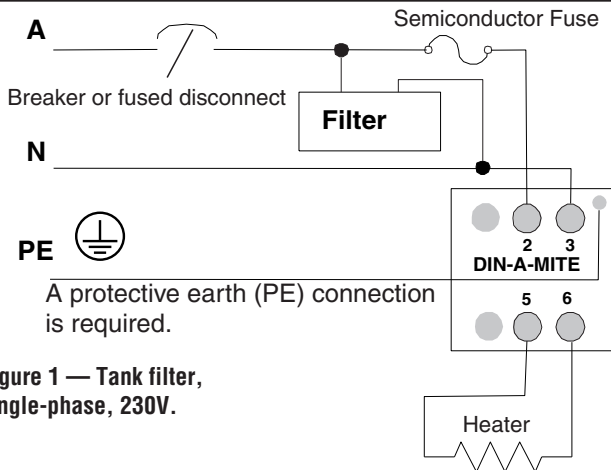

Figure 1 — Tank filter, single-phase, 230V.

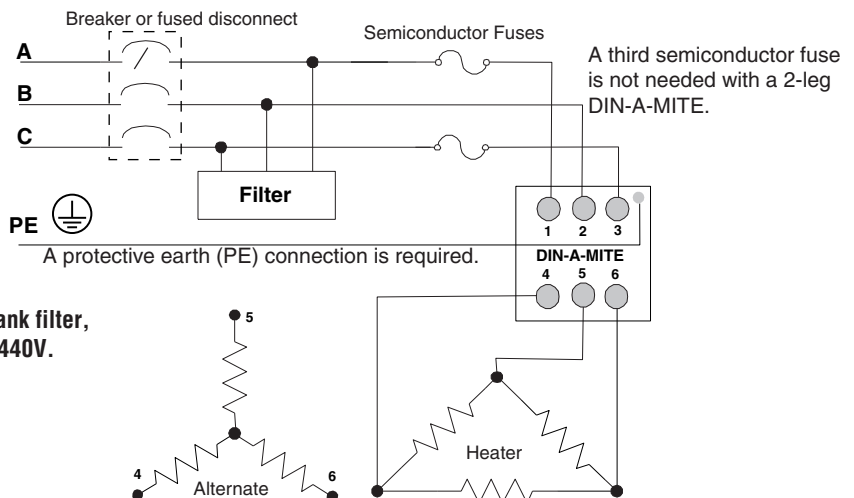

Figure 2 — Tank filter, three-phase, 440V.

## Warranty

The Watlow DIN-A-MITE is warranted to be free of defects in material and workmanship for 36 months after delivery to the first purchaser for use, providing that the units have not been misapplied. Since Watlow has no control over their use, and sometimes misuse, we cannot guarantee against failure. Watlow's obligations hereunder, at Watlow's option, are limited to replacement, repair or refund of purchase price, and parts which upon examination prove to be defective within the warranty period specified. This warranty does not apply to damage resulting from transportation, alteration, misuse, abuse or improper fusing.

## Technical Assistance

If you encounter a problem with your Watlow power controller, review your configuration information to verify that your selections are consistent with your application: inputs, outputs, alarms, limits, etc. If the problem persists, you can get technical assistance from your local Watlow representative, by e-mailing your questions to [wintechsupport@watlow.com](mailto:wintechsupport@watlow.com) or by dialing +1 (507) 494-5656 between 7 a.m. and 5 p.m., Central Standard Time (CST). Ask for an Applications Engineer. Please have the following information available when calling:

- Complete model number
- All configuration information
- User's Manual
- Wiring diagram of your system

The DIN-A-MITE B User's Manual is copyrighted by Watlow, Inc., © June 2010, with all rights reserved.

## Return Material Authorization (RMA)

1. Call Watlow Customer Service, (507) 454-5300, for a Return Material Authorization (RMA) number before returning any item for repair. We need this information:

- Ship to address
- Bill to address
- Contact name
- Phone number
- Method of return shipment
- Your P.O. number
- Detailed description of the problem
- Any special instructions
- Name and phone number of person returning the product.

2. Prior approval and an RMA number from the Customer Service Department is needed when returning any product for credit, repair or evaluation. Make sure the RMA number is on the outside of the carton, and on all paperwork returned. Ship on a Freight Prepaid basis.

3. After we receive your return, we will examine it and try to verify the reason for returning it.

4. In cases of manufacturing defect, we will enter a repair order, replacement order or issue credit for material returned.

5. To return products that are not defective, goods must be in new condition, in the original boxes and they must be returned within 120 days of receipt. A 20 percent restocking charge is applied for all returned stock controls and accessories.

6. If the unit is unrepairable, it will be returned to you with a letter of explanation.

7. Watlow reserves the right to charge for no trouble found (NTF) returns.

# How to Reach Us

## Corporate Headquarters

Watlow Electric Manufacturing Company  
12001 Lackland Road  
St. Louis, MO 63146  
Sales: 1-800-WATLOW2  
Manufacturing Support: 1-800-4WATLOW  
Email: [info@watlow.com](mailto:info@watlow.com)  
Website: [www.watlow.com](http://www.watlow.com)  
From outside the USA and Canada:  
Tel: +1 (314) 878-4600  
Fax: +1 (314) 878-6814

## Latin America

Watlow de México S.A. de C.V.  
Av. Fundación No. 5  
Col. Parques Industriales  
Querétaro, Qro. CP-76130  
Mexico  
Tel: +52 442 217-6235  
Fax: +52 442 217-6403

## Europe

Watlow France  
Tour d'Asnières.  
4 Avenue Laurent Cély  
92600 Asnières sur Seine  
France  
Tél: + 33 (0)1 41 32 79 70  
Télécopie: + 33(0)1 47 33 36 57  
Email: [info@watlow.fr](mailto:info@watlow.fr)  
Website: [www.watlow.fr](http://www.watlow.fr)

Watlow GmbH  
Postfach 11 65, Lauchwasenstr. 1  
D-76709 Kronau  
Germany  
Tel: +49 (0) 7253 9400-0  
Fax: +49 (0) 7253 9400-900  
Email: [info@watlow.de](mailto:info@watlow.de)  
Website: [www.watlow.de](http://www.watlow.de)

Watlow Italy S.r.l.  
Viale Italia 52/54  
20094 Corsico MI  
Italy  
Tel: +39 024588841  
Fax: +39 0245869954  
Email: [italyinfo@watlow.com](mailto:italyinfo@watlow.com)  
Website: [www.watlow.it](http://www.watlow.it)

Watlow Ibérica, S.L.U.  
C/Marte 12, Posterior, Local 9  
E-28850 Torrejón de Ardoz  
Madrid - Spain  
T. +34 91 675 12 92  
F. +34 91 648 73 80  
Email: [info@watlow.es](mailto:info@watlow.es)  
Website: [www.watlow.es](http://www.watlow.es)

Watlow UK Ltd.  
Linby Industrial Estate  
Linby, Nottingham, NG15 8AA  
United Kingdom  
Telephone: (0) 115 964 0777  
Fax: (0) 115 964 0071  
Email: [info@watlow.co.uk](mailto:info@watlow.co.uk)  
Website: [www.watlow.co.uk](http://www.watlow.co.uk)  
From outside The United Kingdom:  
Tel: +44 115 964 0777  
Fax: +44 115 964 0071

## Asia and Pacific

Watlow Singapore Pte Ltd.  
16 Ayer Rajah Crescent,  
#06-03/04,  
Singapore 139965  
Tel: +65 6773 9488 Fax: +65 6778 0323  
Email: [info@watlow.com.sg](mailto:info@watlow.com.sg) Website: [www.watlow.com.sg](http://www.watlow.com.sg)

Watlow Australia Pty., Ltd.  
4/57 Sharps Road  
Tullamarine, VIC 3043  
Australia  
Tel: +61 3 9335 6449  
Fax: +61 3 9330 3566  
Website: [www.watlow.com](http://www.watlow.com)

Watlow Electric Manufacturing (Shanghai) Company  
1118 Fangyuan Road, Anting Industrial Park, Jiading, Shanghai,  
PRC 201203  
People's Republic of China  
Tel: +86 21 39509510  
Fax: +86 21 5080-0906  
Email: [info@watlow.cn](mailto:info@watlow.cn)  
Website: [www.watlow.cn](http://www.watlow.cn)

ワトロー・ジャパン株式会社  
〒101-0047 東京都千代田区内神田1-14-4  
四国ビル別館9階  
Tel: 03-3518-6630 Fax: 03-3518-6632  
Email: [infoj@watlow.com](mailto:infoj@watlow.com) Website: [www.watlow.co.jp](http://www.watlow.co.jp)

Watlow Japan Ltd.  
1-14-4 Uchikanda, Chiyoda-Ku  
Tokyo 101-0047  
Japan  
Tel: +81-3-3518-6630 Fax: +81-3-3518-6632  
Email: [infoj@watlow.com](mailto:infoj@watlow.com) Website: [www.watlow.co.jp](http://www.watlow.co.jp)

Watlow Korea Co., Ltd.  
#1406, E&C Dream Tower, 46, Yangpyeongdong-3ga  
Yeongdeungpo-gu, Seoul 150-103  
Republic of Korea  
Tel: +82 (2) 2628-5770 Fax: +82 (2) 2628-5771  
Website: [www.watlow.co.kr](http://www.watlow.co.kr)

Watlow Malaysia Sdn Bhd  
No. 14-3 Jalan 2/114  
Kuchai Business Centre  
Jalan Kuchai Lama  
58200 Kuala Lumpur  
Malaysia  
Tel: +60 3 7980 7741 Fax: +60 3 7980 7739

瓦特龍電機股份有限公司  
80143 高雄市前金區七賢二路189號 10樓之一  
電話: 07-2885168 傳真: 07-2885568

Watlow Electric Taiwan Corporation  
10F-1 No.189 Chi-Shen 2nd Road Kaohsiung 80143  
Taiwan  
Tel: +886-7-2885168 Fax: +886-7-2885568

### Your Authorized Watlow Distributor