

*User's manual*

# Set-point-transmitter D122.T



Edition of standards 2010, Software version 1.2.0



**Gönnheimer  
Elektronik GmbH**

<http://www.goennheimer.de> Email: [info@goennheimer.de](mailto:info@goennheimer.de)





Zert. Reg. Nr. Q1 0297038

Dr.-Julius-Leber-Straße 2  
67433 Neustadt/Weinstraße  
Postfach 10 05 07  
67405 Neustadt  
phone: +49 (6321) 49919- 0  
fax: +49 (6321) 49919 - 41

## Table of Contents

<b>1</b>	<b>Operation instruction for Explosion protected device</b>	<b>4</b>
<b>2</b>	<b>Transmitter D122.T</b>	<b>5</b>
2.1	Short description	5
2.2	Features overview	5
2.3	Conformity with Standards	6
<b>3</b>	<b>Installation and Connection</b>	<b>6</b>
3.1	D122.T with control panel housing	6
3.1.1	Installation control panel housing	6
3.1.2	Connecting D122.T with control panel housing	6
3.2	Field housing D122.T	7
3.2.1	Connecting D122.T with field housing	7
3.3	Initial operation	8
3.3.1	Ex works settings – Device reset	8
<b>4</b>	<b>Operation manual</b>	<b>9</b>
4.1	Front view and push-keys	9
4.2	Configuration	10
4.3	Configuration example	13
<b>5</b>	<b>Flow charts</b>	<b>16</b>
<b>6</b>	<b>Annex</b>	<b>19</b>
6.1	Specifications	19
6.2	Type code	19
6.3	Dimensions	20
6.4	Application example: connection plan	21
6.5	Material specification	21
6.6	Marking	21
6.7	Transport, Storing, Repairs und Disposal	22
6.8	Failure messages	22
6.9	List of Parameters	22

## The symbols WARNING, CAUTION, NOTE

 <b>Warning</b>	This symbol warns of a serious hazard. Failure to observe this warning may result in death or the destruction of property.
 <b>Caution</b>	This symbol warns of a possible failure. Failure to observe this caution may result in the total failure of the device or the system or plant to which it is connected.
 <b>Note</b>	This symbol highlights important information.

# 1 Operation instruction for Explosion protected device

## Application and Standards

This instruction manual applies to explosion-protected control panels of type of protection types below. This apparatus is only to be used as defined and meets requirements of EN 60 079 particularly EN60 079-14 "electrical apparatus for potentiality explosive atmospheres".

Use this manual in hazardous locations, which are hazardous due to gases and vapours according to the explosion group and temperature class as stipulated on the type label. When installing and operating the explosion protected distribution and control panels you should observe the respective nationally valid regulations and requirements.

## General Instructions

The device has to have a back-up fuse as stipulated. The mains connection must have a sufficient short circuit current to ensure safe breaking of the fuse. To achieve an impeccable and safety device operation, please take care for adept transportation, storage and mounting, as well as accurate service and maintenance. Operation of this device should only be implemented by authorised persons and in strict accordance with local safety standards.



The electrical data on the type label and if applicable, the "special conditions" of the test certificate **Fehler! Unbekannter Name für Dokument-Eigenschaft.** are to be observed.

For outdoor installation it is recommended to protect the explosion protected distribution and control panel against direct climatic influence, e.g. with a protective roof. The maximum ambient temperature is 40°C, if not stipulated otherwise.

## Intrinsically Safe Circuits

Erection instructions in the testing certificates of intrinsically safe apparatus are to be observed. The electrical safety values stipulated on the type label must not be exceeded in the intrinsically safe circuit. When interconnecting intrinsically safe circuits it is to be tested, whether a voltage and/or current addition occurs. The intrinsic safety of interconnected circuits is to be ensured. (EN 60079-14, section 12)

## Safety Measures: to read and to comply

 <b>Warning</b>	<p>Work on electrical installations and apparatus in operation is generally forbidden in hazardous locations, with the exception of intrinsically safe circuits. In special cases work can be done on non-intrinsically safe circuits, on the condition that during the duration of such work no explosive atmosphere exists. Only explosion protected certified measuring instruments may be used to ensure that the apparatus is voltage-free. Grounding and short-circuiting may only be carried out, if there is no explosion hazard at the grounding or short circuit connection.</p>
 <b>Warning</b>	<p><b>Danger of static charge!</b></p> <p><b>Clean only with humid cloth!</b></p> <p><b>Do not open when an explosive dust atmosphere is present!</b></p>

## 2 Transmitter D122.T

### 2.1 Short description

The purpose of the D122.T is to make set-point adjustments, like e.g. temperature, pressure or revolution, inside the explosion endangered area to e.g. high level control units outside explosion endangered areas, via a 4/20 mA current circuit.

The scale span of the transmitter amounts 2000 digits. An additional power supply is not necessary, because the D122.T is in loop like a transmitter into the circuit of a transmitter power supply.

The indicated value corresponds with the real measured current in the control circuit - it is not just a static display. So, the user has control of the transmitted set point. Push and hold the current control button to indicate the physical current in dimension mA.

The D122.T has a configurable incremental set point- setting. The user sets a new set point by pressing the arrow buttons to increment or decrement the desired set point. The incremental set point- setting works first with an resolution of 1 digit and furthermore with an adjust progression – so wide set point- adjustments can be done quickly.

Use an additional D122.A indicator to indicate the actual value of the feedback control system. Therefore, a hazardous area located simple process visualisation of a feedback control system.

### 2.2 Features overview

- Ex i- Set-point transmitter D122.T into 4 /20 mA control circuit
  - Loop powered - easy use in hazardous area, no additional power supply necessary
  - Connecting like common transmitters
- Display
  - 41/2-digit 7-Segment display, 2000 digits
  - LC-Display 30 mm digit height
  - Fast bargraph for trend observation, (41 segments, refresh 4 times per second)
- Housings
  - Control panel housing, protection class up to IP 55 (HxWxD) 72x144x80 mm
  - Field housing, protection class IP 65 (HxWxD) 133,5x138x64 mm
- Ergonomics
  - µ-Processor technology for extensive configuration
  - Scaled by keyboard and display, without reference current
  - Separately scaleable bargraph (Zoom)
  - Incremental set point setting (software version 1.1.0 and later)
  - Current control button (not available by incremental set point setting)
  - Keeps the configuration after turn off
  - Ability to change configuration during operation
  - Exchangeable dimension signs
- Service
  - Customised calibration

## 2.3 Conformity with Standards

The explosion proof indicators type D122.T meets requirements of listed standards in the attachment (Declaration of conformity). They were developed, manufactured and tested in accordance with state-of-the-art engineering practice and ISO9001:2008.

## 3 Installation and Connection

### 3.1 D122.T with control panel housing

#### 3.1.1 Installation control panel housing

The D122.T.3 is predicated for installation in a control panel.

How to insert the dimension symbol

Insert the dimension symbol (icon) before mounting. Do this by first removing the front frame as shown in the figure at left. Now remove the front panel from the housing as shown in the figure on the right.

Cut the desired dimension symbol out of the set and pull it into its intended place on the right side of the panel. Make sure that the symbol is facing the front. Replace the front panel and frame.

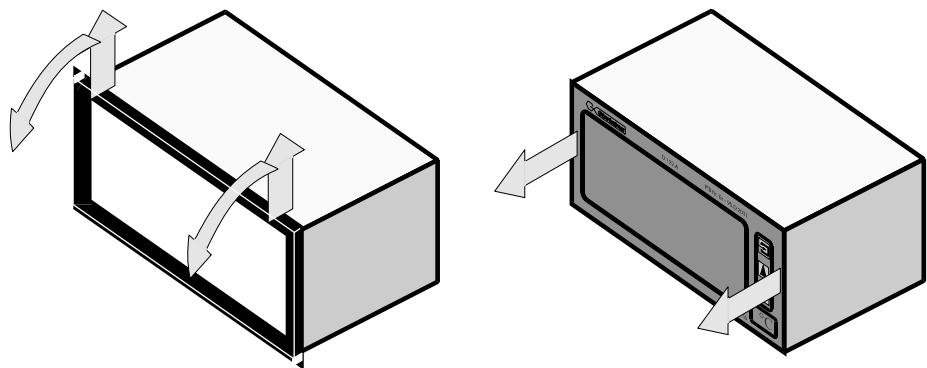

How to fix the device in the control panel

Fix the device into the control panel with the intend cramps.

#### 3.1.2 Connecting D122.T with control panel housing



**Caution**

Connect the indicator only to intrinsically safe 4..20 mA current circuits.

The terminals of the indicators in the control panel housing are shown in figure **Fehler! Verweisquelle konnte nicht gefunden werden..** The terminals 5,6 and 7,8 are absent by indicators without alarm monitoring.



### Caution

Please regard the terminal maximum values of the attached EC- type certificate TÜV 99 ATEX 1488 .

Control panel enclosure  
Terminals

The terminals of the transmitter in the control panel housing are on the backside.

Terminal	Comment
1	+ terminal 4 ..20 mA control circuit
2	- terminal 4 ..20 mA control circuit

## 3.2 Field housing D122.T

Choose a solid place to install the transmitter in the field area.

How to insert the dimension symbol

First, cut the desired dimension symbol out of the set. Then pull off the four screws of the cap and remove the cap from the housing.

Now push the prepared dimension symbol into the dimension symbol slot. Make sure that the symbol is facing the front.

The dimension symbol slot are below the display, on the internal side of the cap.

Finally replace the cup on the housing.

### 3.2.1 Connecting D122.T with field housing



### Caution

Connect the indicator only to intrinsically safe 4..20 mA current circuits.

The terminals of the indicators in the control panel housing are shown in figure **Fehler! Verweisquelle konnte nicht gefunden werden.** The terminals 5,6 and 7,8 are absent by indicators without alarm monitoring.



### Caution

Please regard the terminal maximum values of the attached EC- type certificate TÜV 99 ATEX 1488 .

Field housing  
Terminals

The terminals of the transmitter with field housing are inside.

Terminal	Comment
1	+ Terminal 4..20 mA control circuit
2	- Terminal 4..20 mA control circuit

### 3.3 Initial operation



#### Note

After connecting, a **display test** (all segments of the display are on) appears immediately during one second. Thereupon the display shows the **software version** of the transmitter.

#### Default parameters

The following parameters are active ex works:

Scale (figure and bargraph)

- 4 mA measured current -> 4.00
- 20 mA measured current -> 20.00

Set point

- 4 mA measured current -> 4.00
- Direct set point setting

Code words

- CODE1: 0001
- CODE2: 0002

#### 3.3.1 Ex works settings – Device reset



#### Note

Press the Enter- and Right-button during the start sequence to reactivate the default parameters. (Hardware-Reset)

A reset activates also the ex works calibration.



## 4 Operation manual

### 4.1 Front view and push-keys

- Front view

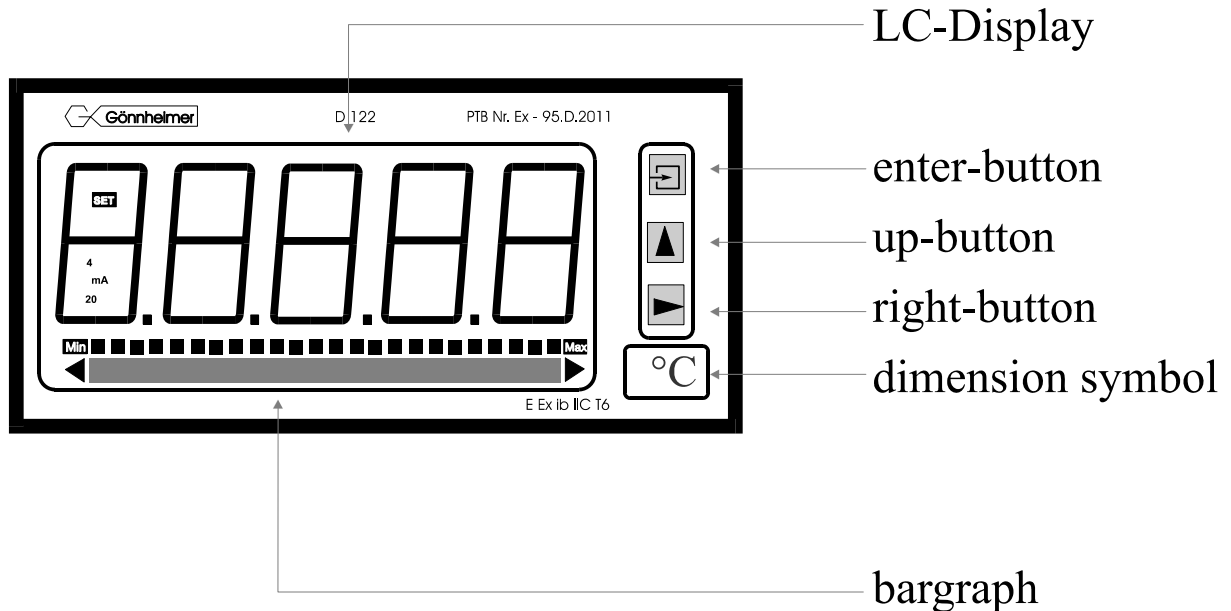

- Keys

On the front side of the transmitter are three buttons with several function symbols. With these three buttons the user can activate each function and enter any parameters for any individual setting.

Each button is named by its function:

#### *Enter-button*

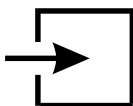

Pressing the *enter*-button starts the input menu. In general, the *enter*-button activates the menu item or accepts the manipulated value of a parameter.

#### *Up-button*



Functions of the up-button are:

1. present current value button or **increment set point**
2. modification of the selected figure
3. pass menu items

#### *Right-button*

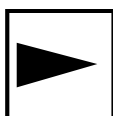

Functions of the right-button are:

1. change the state to set point edit menu or **decrement set point**
2. select figures
3. pass menu items

## 4.2 Configuration

It is easy to set the parameters and change the configuration of the transmitter. The inputs are logical grouped by a menu structure. The **flow charts** of these menus can be found at chapter 5.

### Note Flow charts

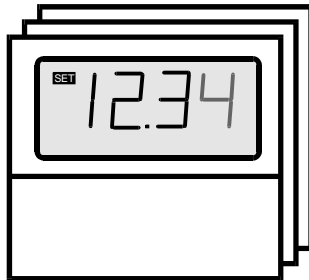

#### Normal state

The **Input-views in the flow diagrams have additional boxes in their background**, because the Input-views may be changed by pressing any button.

The procedure, to enter a value, is shown in the flow chart 'Edit menu', see Figure 4: Flow chart edit mode

After connecting, the transmitter D122.T starts to initialise its configuration. The configuration data is stored in an internal EEPROM due to the previous run. On the first start, the D122.T transmitter initialises the ex works configuration.

Directly past starting sequence the transmitter begins to operate. This state is called the 'normal state' of the D122.T and the transmitter is also ready for inputs.

(See also flow diagram in Figure 1)

#### Set point adjusting

It is possible to adjust the set point in two ways:

1. **Direct set point setting:** the user pushes the *right*-button following the *enter*-button. The D122.T is then in the set point edit mode and the user can enter the new set point by editing the figures of the set point.
2. **Incremental set point setting:** the transmitter is in normal state. The user pushes the *up*-button to increment the set point or he pushes the *right*-button to decrement the set point.

Configure the way of the set point adjustment in the input menu of the D122.T (as shown below). The direct set point setting is configured ex works.

### Tip\*

If the incremental set point setting is active – then the present current control as well as the direct set point setting is not available.

#### Present-value control\*



Pushing and holding the *up*-button (**present value control button**) the display shows the present measured value.

(See also flow diagram in Figure 1)

## ☞ Direct set point setting\*

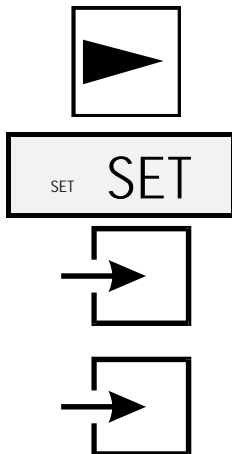

One touch on the *right*-button starts the preset menu.

(See also flow diagram in Figure 1: flow chart normal state)

The transmitter screen shows "SET".

Press the *enter*-button to see the present preset value.

Press the *enter*-button a second time, to change the preset value.

The display switches into the

- Edit mode.

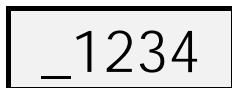

A blinking segment appears below the sign place. Pressing the *right*-button selects the figures and the *up*-button increments the selected figure. To accept the new preset value, press the *enter*-button.

(See also flow diagram in Figure 4)

- Code protection



Before the menu gets to the edit mode the **code 2** must be entered, to **prevent a modification by unauthorised persons**. Entering a wrong code word stops the limit view menu immediately.

The default code 2 is [0002].



**Caution**

The interrogation of **code 2 can be switched off** by modifying the code 2 to **[0000]**. For this reason the flow diagram shows the code interrogation in stroked dots. To change the code you must enter the input menu, as shown below in this chapter.

- Parameter entering

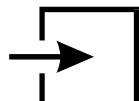

(See also flow diagram in Figure 2)

Back in the normal state of the transmitter we start the

## ☞ Input menu



by pressing the *enter*-button.

The **configuration of the transmitter is protected** against manipulations by unauthorised persons with the **code 1**. To join the input menu enter the code 1. (Default: 0001).

It's **impossible to switch off the code 1** interrogation.

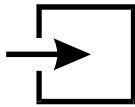

After entering the right code word the transmitter proposes to join the

SCAL

**Scale menu.** The figure on the left hand appears on the display.

To scale the **measured current**, the **bargraph** and to **set the decimal point** join the scale menu by confirming with the *enter*-button.

(See also flow diagram in Figure 3).



**Note**

Enter the upper scale point correct figured 'as big as possible' (the first figures should not be '0')

In this case you get the maximum precision of the transmitter.

SET

Press the *right*-button to pass the scale menu and select the second submenu, the preset menu. To join it, press the *enter*-button.

(See also flow diagram in Figure 4)

roll

This is the menu item to configure the way of the set point setting.

Start with pressing the *enter*-button. Now toggle between [roll n] (= roll – no i.e. direct set point setting) and [roll y] (= roll – yes, i.e. incremental set point setting) by pressing any arrow button.

Confirm the desired configuration by pressing the *enter*-button.

CodE 1

The next two following items allow to manipulate the words for code 1 and code 2. The *enter*-button confirms the input and the corresponding code appears in edit mode.

CodE 2

Remember that the code word [0000] will switch off the code 2.

CAL

Finally it's possible to calibrate the transmitter with the following submenu called calibration menu. Regard, the transmitter is already calibrated ex-works.



**Note**

**In general, a further calibration is not necessary and only experienced persons are allowed to calibrate it.**

End

Now we reach the end of the input menu. Confirm all settings with the *enter*-button. The transmitter switches back to normal state.

If you want to repeat the input menu, press the *right*-button.



## Note

If an invalid value is entered for any of the parameters, you will not be able to quit the input menu. Instead, the menu program switches automatically into edit mode to the identified invalid value.

### 4.3 Configuration example

For a successful parameter input, see the following example of a temperature transmitter. This demonstration is based on the ex works settings (default parameters). If you had already made other settings reset the transmitter, as shown in chapter 3.3, Make a reset to the device to get back the default parameters.

#### Situation

- Preset range:  
-20,0°C ...+150,0°C

#### Adjustment:

- 1] Measure range: -020,0 °C ... + 150,0°C  
for 4 ... 20 mA
- 2] Bargraph: -020,0°C ... + 150,0°C
- 3] Incremental set  
point setting

#### Procedure:



CodE1

One touch on the enter-button quits the normal state and starts **the input menu**.

The menu interrogates for code 1.

The default code 1 is [0001].

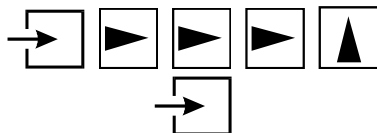

Enter the right code word using the arrow buttons.

Finally hit the *enter*-button.

- Scaling display and barograph:

SCAL

Join the **scale menu** by pressing the *enter*-button.



dP.Pos

First set the **position of the decimal** point. The position of the decimal point will be used for each parameter, like display, bargraph and preset value.

Set the decimal position after the third position (counted from left side), because we will enter [1500] for the high scale point afterwards.







Choose the *enter*-button to edit the decimal point position and push the *right*-button. Watch the display, the decimal point shifts right.

Press the *enter*- button, to quit decimal point setting.

SCA L  

\_040.0  

- 040.0  
 

-040.0  
 ... 

-020.0  

SCA H

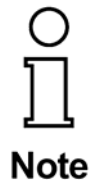

bAr L

bAr H



roll

Now the [scale point low] view appears.

Edit by pressing the *enter*-button and enter the **lower scale point** [0200] (-20°C) as follows:

Press the *up*- button to select the negative symbol.

Now press the *right*- button for two times to select the second figure.

Repeat pushing the *up*-button until ...

... the figure 2 appears.

confirm the lower scale point by pushing the *enter*-button, so the scal point high parameter (SCA H) will be displayed .

According above, enter now the figure sequence [1500] to the set the scal point high to 150°C. (Confirm with the *enter*-button).

Enter the upper scale point correct figured 'as big as possible' (the first figures should not be '0')

In this case you **get the maximum precision of the transmitter.**

It is not possible to set a preset range bigger than 2000 digits. The device refuses a bigger range. But it is possible to place the pre-set range of 2000 digits in the range of -9999 to +9999 (e.g. 6000 ... 8000).

Now **scale the bargraph.** Hit the *enter*-button.

Enter [-0200] (-20 °C) for the lower bargraph scale point.

Confirm by hitting the *enter*-button.

Enter [1500] (150°C) for the upper bargraph scale point.

Pushing *enter*-button accepts and quits the scale menu.

Pass the menu point [Set ] by pressing the *right*-button.

Now configure the incremental set point setting. First press the *enter*-button. Then press the *up*-button to select [roll y].

Finally confirm by pushing the *enter*-button.



We pass simply the following menu items (manipulate code words and calibrate) using the *right*-button.



Finally quit the input menu hitting the *enter*-button.



The transmitter is back in normal state. The changes are immediately active and will still be active after power off (disconnecting the transmitter).

## 5 Flow charts

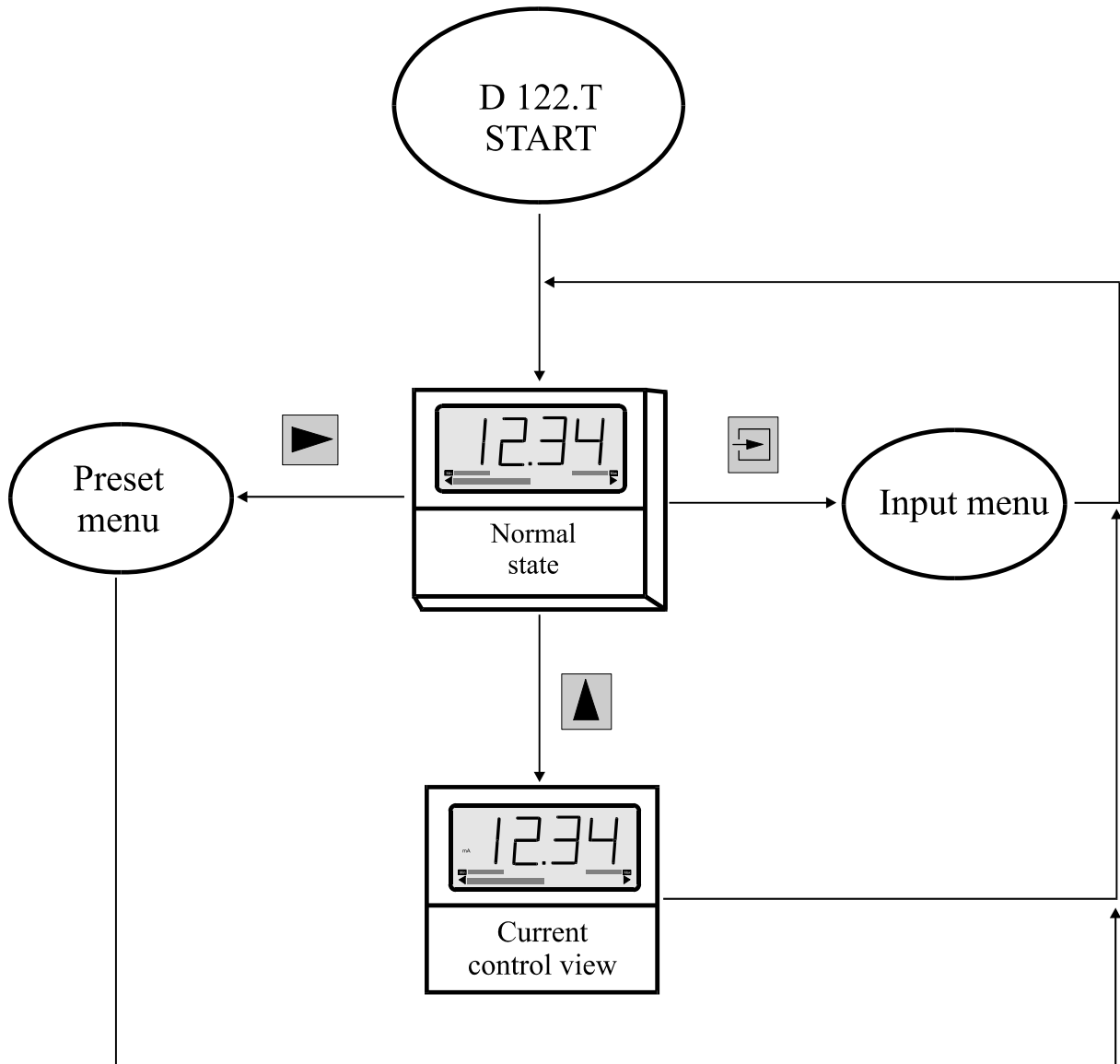

Figure 1: flow chart normal state (by direct set point setting only)



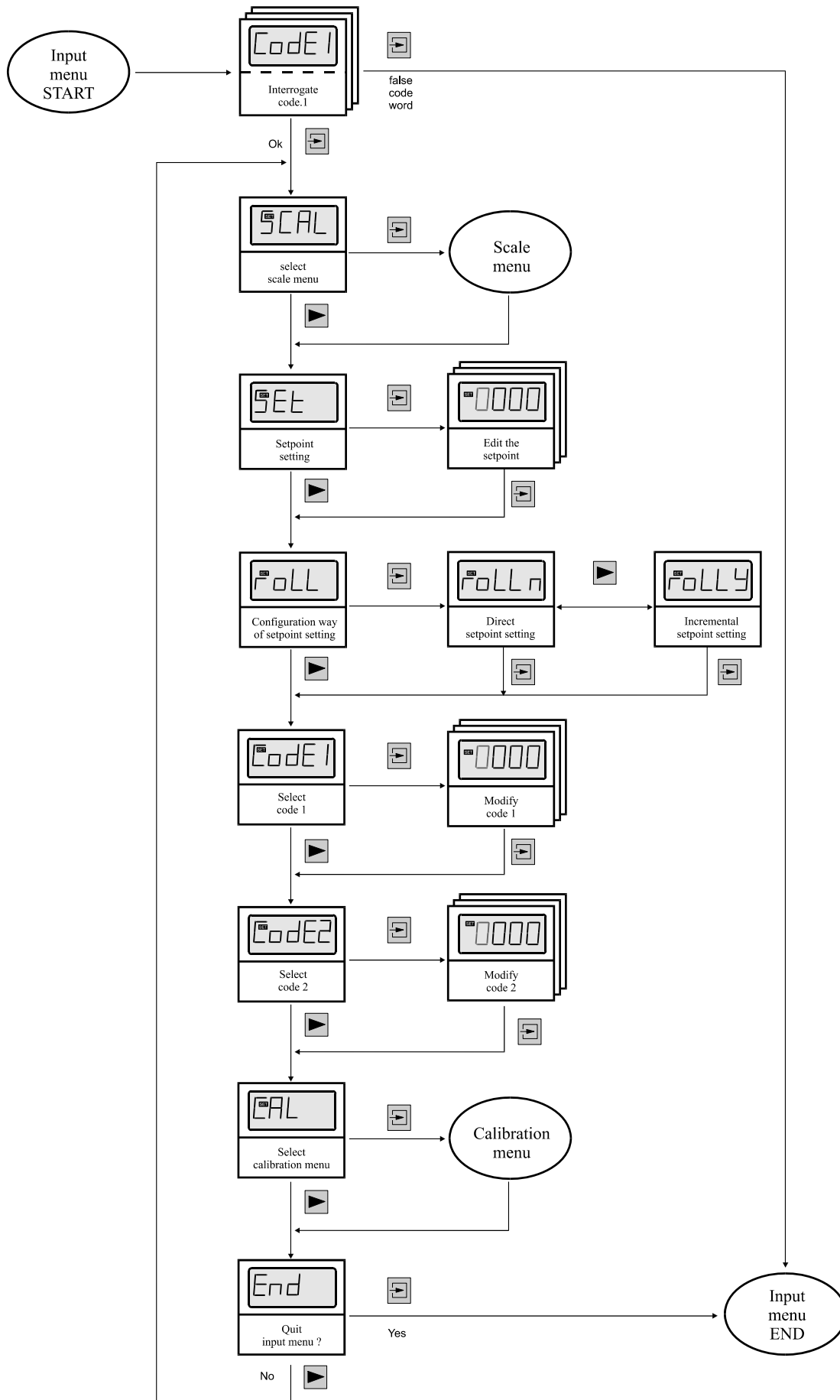

Figure 2: Flow chart input menu

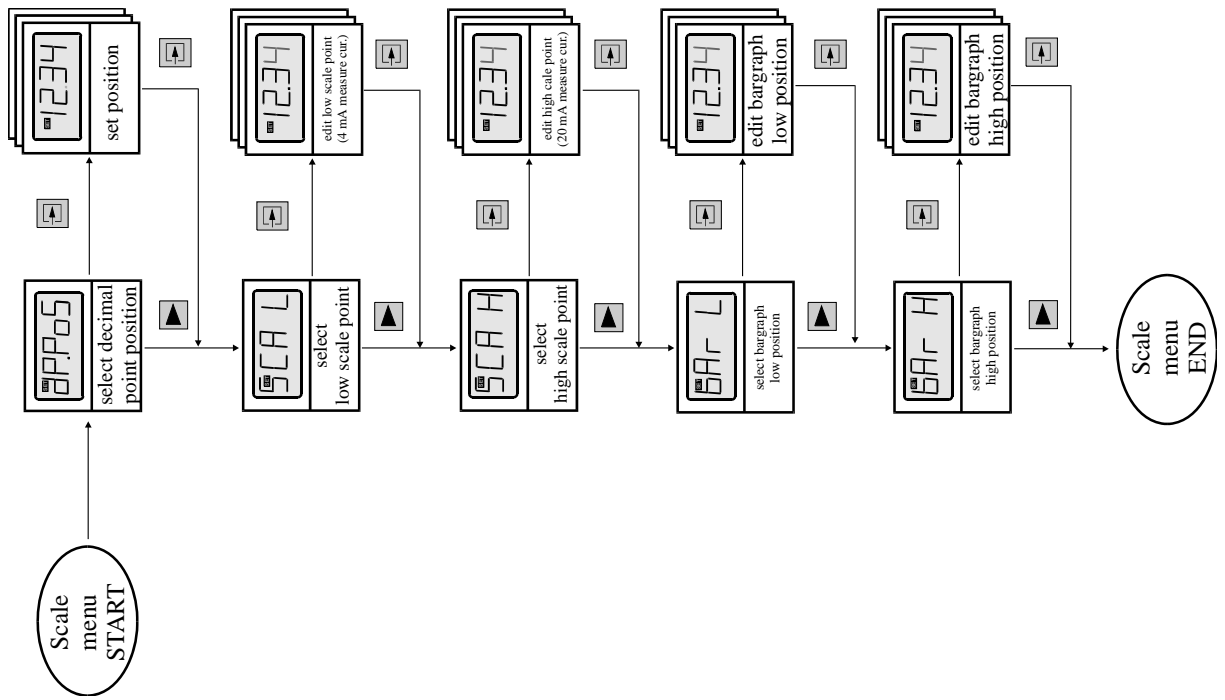

Figure 3: Flow chart scale menu

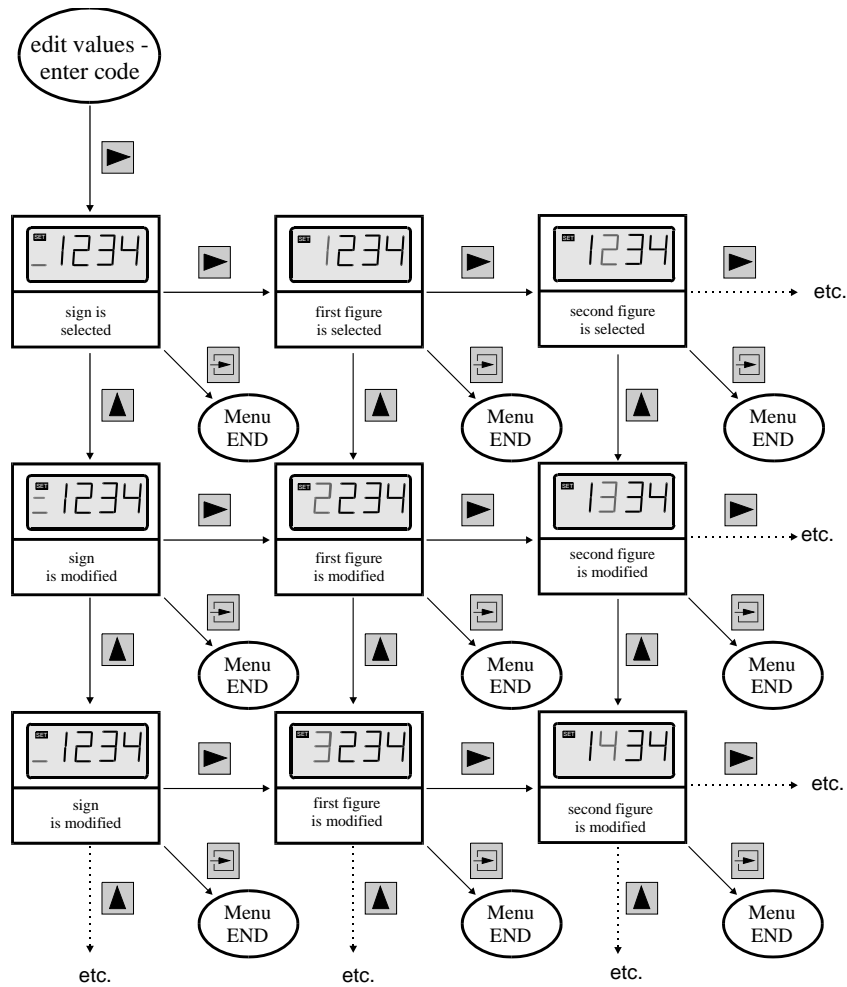

Figure 4: Flow chart edit mode

## 6 Annex

### 6.1 Specifications

	D122.T	
	D122.T.3	D122.T.5 (7)
Display	seven-segment LCD	
Digit height	30 mm	
Display range	4 1/2 figures, 2000 Digits	
Dimension symbols	Selectable by defined symbols	
Decimal points	Selectable by keyboard	
Bargraph	41 segments, refresh 4 Hz	
control circuit	Intrinsically safe control circuit 4 ...20 mA, Voltage range 8 ..30V; Voltage drop ca. 8V	
Current control button	Direct current indication in control circuit	
control circuit limits	No-load voltage $U_l = 65 \text{ V}$ , short-circuit current $I_l = 160 \text{ mA}$ ; $P_l = 1,6 \text{ W}$ Internal inductance: $< 40 \mu\text{H}$ , Internal capacitance: $< 10 \text{ nF}$ , see certificate PTB 99 ATEX 1488	
Explosion protection	E Ex ib IIC T6 at ambient temperature 45°C or E Ex ib IIC T5 at ambient temperature 60°C	
Housing	Acc. to control-panel standard DIN 43700	-
Environment Protection	Front panel IP 40 up to IP 55	IP 65
Dimensions HxWxD [mm]	72 x 144 x 80	133,5 x 138 x 82
Control panel hole	66 x 136,5	
Material	glass fibre strengthened Noryl	ABS
Measuring error	0,1% $\pm$ 2 digits referring to measure range	
Temperature coefficient	$< 0,01\%$ of measure range / K	
Ambient temperature limit	-10°C ...+45°C at temperature class 6 or -10°C ...+60°C at temperature class 5 devices for -20°C ambient temperature on inquiry	

### 6.2 Type code

Set-point transmitter D122.T .x

Housing:

Control panel housing ..... .3

Field housing ..... .5

### 6.3 Dimensions

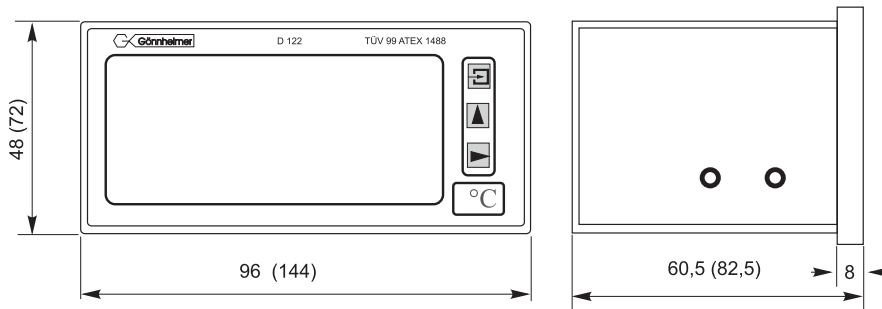

Figure 5: Control panel housing, only the dimensions in brackets are valid

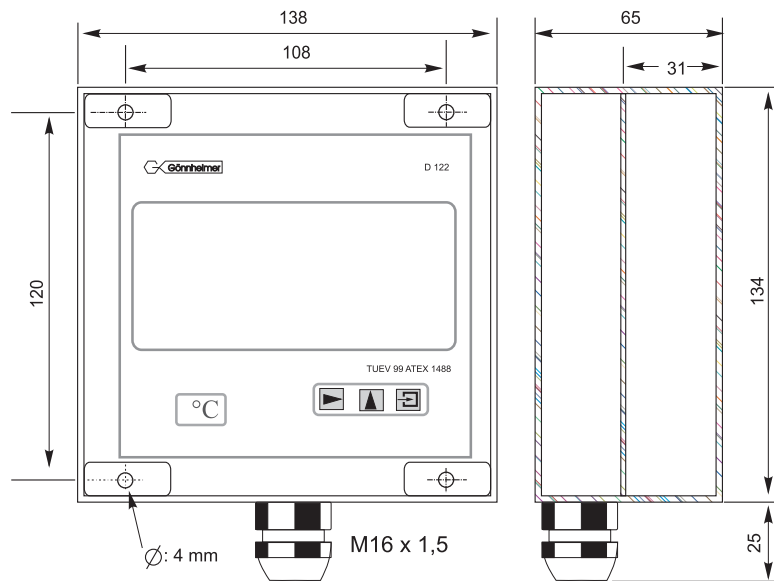

Figure 6: Field housing D122.T.5

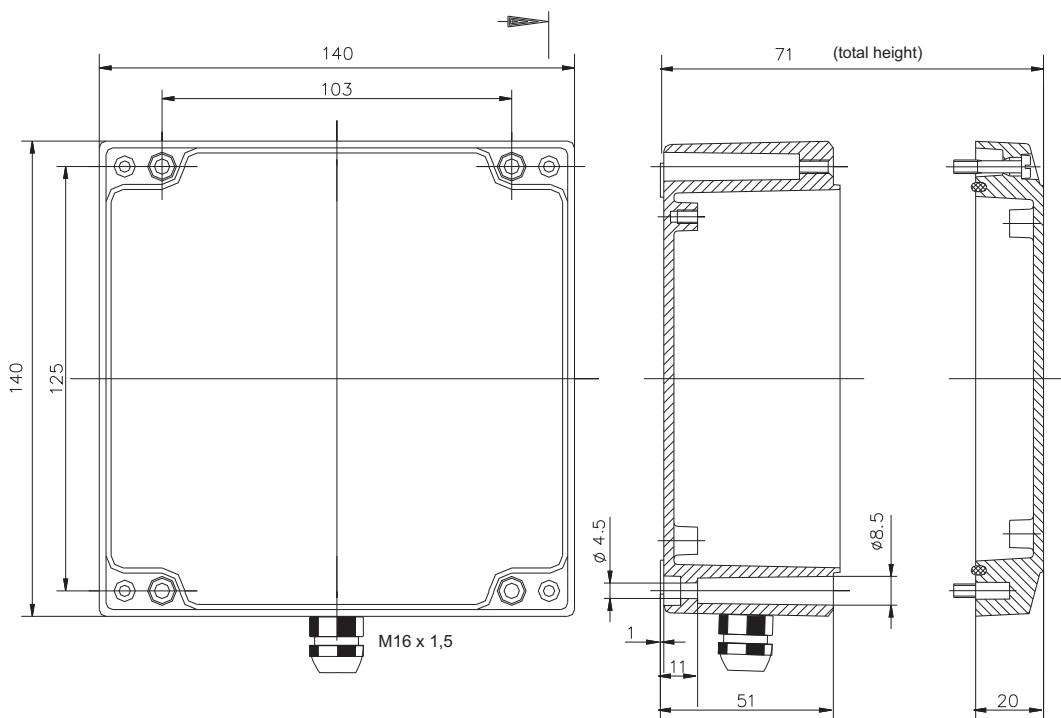

Figure 7: Field housing D122.T.5

## 6.4 Application example: connection plan

Set-point transmitter D122.T

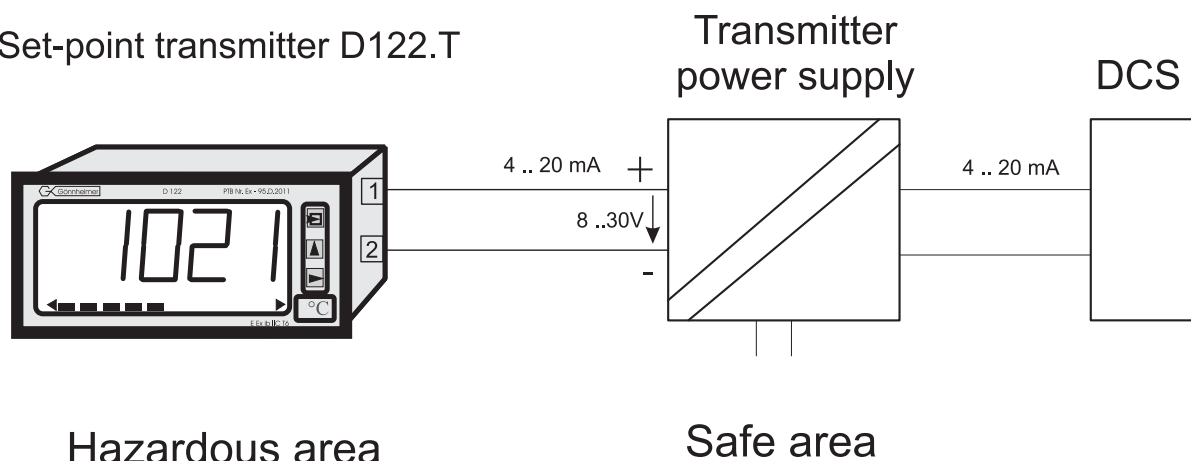



Figure 8: connection plan

## 6.5 Material specification

Device type	Material	manufacturing process
D122.x.0.x.x	Noryl	injection die casting
D122.x.3.x.x	Noryl	injection die casting
D122.x.5.x.x	ABS	injection die casting
D122.x.6.x.x	ABS	injection die casting
D122.x.7.x.x	Aluminum	die-casting

## 6.6 Marking

	Marking according to 50014 ff	Marking according to EN 60079:2010
D122.x.x.x.0 D122.x.x.x.MU	II 2 G; EEx ia IIC T6 bei Ta bis 45°C II 2 G; EEx ia IIC T5 bei Ta bis 60°C	II 2 G; Ex ia IIC T6 Gb bei Ta bis 45°C II 2 G; Ex ia IIC T5 Gb bei Ta bis 60°C
D122.x.x.x.BM	II 2 G; EEx ia [ib] IIC T6 bei Ta < 45°C II 2 G; EEx ia [ib] IIC T5 bei Ta < 60°C	II 2 G; Ex ia [ib] IIC T6 Gb bei Ta < 45°C II 2 G; Ex ia [ib] IIC T5 Gb bei Ta < 60°C
D122.x.7.x.0 D122.x.7.x.MU	II 2 G; EEx ia IIC T6 bei Ta < 45°C II 2 G; EEx ia IIC T5 bei Ta < 60°C II 2 D; Ex IP65 T70°C	II 2 G; Ex ia IIC T6 Gb bei Ta < 45°C II 2 G; Ex ia IIC T5 Gb bei Ta < 60°C II 2 D; Ex tb IIIC IP65 T70°C Db
D122.x.7.x.BM	II 2 G; EEx ia [ib] IIC T6 bei Ta < 45°C II 2 G; EEx ia [ib] IIC T5 bei Ta < 60°C II 2 D; Ex IP65 T 70°C	II 2 G; Ex ia [ib] IIC T6 Gb bei Ta < 45°C II 2 G; Ex ia [ib] IIC T5 Gb bei Ta < 60°C II 2 D; Ex tb IIIC IP65 T70°C Db

## 6.7 Transport, Storing, Repairs und Disposal

<b>Transport</b>	Vibration-free in origin package, do not pitch, handle carefully
<b>Storing</b>	Store the device dry, inside of the origin package
<b>Disposal</b>	When the explosion proof multipurpose distribution, switching and control units are eventually disposed of, the national regulations governing the disposal of waste materials in the country concerned must be rigorously observed.
<b>Repairs</b>	Defective parts may only be replaced by the Manufacturer or by personnel specially trained and supervised by the Manufacturer. Only genuine spare parts from the Manufacturer may be fitted.

## 6.8 Failure messages

At startup:

Message	Symptom	Bug-fix
Error 1	Error, general device fault	Turn off an turn on the device, if the fault remains, send the device back to Gönneheimer

## 6.9 List of Parameters

The customer is free to use this chart for archiving the parameters of his transmitter D122.T.

Parameter	Description	previous Display	Value
<b>Scale menu</b>			
Decimalpoint position		dP.PoS	0 0 0 0
Low scale point	Display at 4 mA input current	SCAL L	
High scale point	Display at 20 mA input current	SCAL H	
Bargraph low position	Display of starting bargraph	bAr L	
Bargraph high position	Display at full bargraph	bAr H	
Way of set point setting	direct or incremental	roll n roll y	
Code 1	Access code to rescale and configure the transmitter	Code1	
Code 2	Access code to set the preset	Code2	



(1) **EC- TYPE- EXAMINATION CERTIFICATE**  
(Translation)

(2) Equipment and protective systems intended for use in potential explosive Atmospheres – **Directive 94/9/EC**

(3) EC- type- examination Certificate number

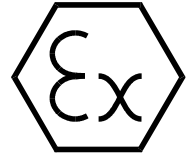

**TÜV 99 ATEX 1488**

(4) Equipment: Digital Indicator Type D122...

(5) Manufacturer: Gönzheimer Elektronik GmbH

(6) Address: D-Neustadt an der Weinstraße

(7) This equipment and any acceptable variation thereto are specified in the schedule to this certificate and the documents therein referred to.

(8) The TÜV Hannover/Sachsen-Anhalt e.V., TÜV CERT-Zertifizierungsstelle, notified body No. 0032 in accordance with Article 9 of the Council Directive 94/9/EC of March 1994, certifies that equipment has been found to comply with the Essential Health and Safety Requirements relating to the design and construction of equipment and protective systems intended for use potentially explosive atmospheres, given in Annex II to the Directive.

The examination and test results are recorded in the confidential report No. 99/PX24090

(9) Compliance with to essential Health and Safety Requirements has been assured by compliance with:

**EN 50 014:1997 EN 50 020:1994 EN 50 028:1988**

(10) If the sign "X" is places after the certificate number, it indicates that the equipment is subject to special conditions for safe use specified in the schedule to this certificate.

(11) This EC- type- examination Certificate relates only to the design and construction of the specified equipment in accordance with Directive 94/9/EC. Further requirements of this Directive apply to the manufacture and supply of this equipment.

(12) The marking of the equipment shall include the following:

 **II 2 (1) G EEx ia IIC T6 bzw. EEx m [ib] IIC T6**

TÜV Hannover/Sachsen-Anhalt e.V.  
TÜV CERT-Zertifizierungsstelle  
Am TÜV 1  
D-30519 Hannover

Hannover, 02.11.1999



Der Leiter



(13)

## SCHEDULE

(14) EC- TYPE-Examination CERTIFICATE No. TÜV 99 ATEX 1488

(15) Description of equipment

The digital indicator type D122 ... serves as direct indicator of measured values of intrinsically safe 4 ..20 mA current circuits in explosive endangered areas.

The maximum ambient temperature is 45°C in temperature class T6 and 60°C in the temperature class T5.

### Electrical details

Supply and  
signal current  
circuit  
(Terminal 1,2)

Exclusive connection to a certificated intrinsically safe current circuit with the following highest values:

$U_i = 65 \text{ V}$   
 $I_i = 160 \text{ mA}$

Effective internal inductivity 40  $\mu\text{H}$   
Effective internal capacity 10 nF

### Only Type D122.T.x.x.x

Supply and  
signal current  
circuit  
(Terminal 1,2)

Exclusive connection to a certificated intrinsically safe current circuit with the following highest values:

$U_i = 30 \text{ V}$   
 $I_i = 160 \text{ mA}$   
 $P_i = 1,6 \text{ W}$

Effective internal inductivity 40  $\mu\text{H}$   
effective internal capacity 10 nF

Terminals 3,4

Bridget

### Only TYP 122.x.x.x.BM with additional protection type moulding and the sign EEx m [ib] IIC T6 bzw. EEx m [ib] IIC T5

Input current  
circuit (wire)

$U_m = 250 \text{ V}$  and to connect to ground





Schedule EC- Type- Examination Certificate No. TÜV 99 ATEX 1488

---

**Any types**

Alarm current circuits (Terminal 5,6; 7,8) Outputs:	Exclusive connection to a certificated intrinsically current circuit with the following highest values each current circuit:  $U_i = 30 \text{ V}$ $I_i = 160 \text{ mA}$ $P_i = 850 \text{ mW}$
Inputs:	$U_i = 30 \text{ V}$  Effective internal inductivity $\leq 40 \mu\text{H}$ the effective internal capacity is negligibly small

All current circuits are safe galvanically separated up to a nominal voltage of 90 V to each other. The input current circuit by the type D122.x.x.x.BM is internally connected to the supply and signal circuit.

- (16) Report No. 99/PX24090
- (17) Special conditions for safe area  
None
- (18) Essential health and safety requirements  
No additional



# 1. Amendment to the Conformity Certificate Nr. TÜV 99 ATEX 1488

Manufacturer: Gönzheimer Elektronik GmbH  
Dr.-Julius Leber-Str.2  
D-67433 Neustadt/Weinstraße

The digital indicator type D122 can also be manufactured according to the examination protocol, listed in the associated examination certificate.

The changes concern the enlargement around the type D122.x.7.x.x. and the application of type in explosion areas by dust up to ambient temperatures of 65°C. The marking for it is:

**II 2 D IP 65 T70°C**

Bases of the standards: EN 50281 1 1:1999

The electric data and all other information are valid consistently for this supplement.

The test documentation is listed in test report Nr. 04YEX551218

TÜV NORD CERT GmbH & Co. KG

Hannover, 17.02.2004

TÜV CERT-Zertifizierungsstelle  
Am TÜV 1  
0-30519 Hannover  
Tel.: 0511 986-1470  
Fax: 0511 986-2555

Der Leiter



## 2. Amendment to the Conformity Certificate Nr. TÜV 99 ATEX 1488

Manufacturer:           Gönzheimer Elektronik GmbH  
                                   Dr.-Julius Leber-Str.2  
                                   D-67433 Neustadt/Weinstraße

The digital indicator type D122 can also be manufactured according to the examination protocol, listed in the associated examination certificate. The change concerns the enlargement around the types D122.PA.7.0.0 and D122.FF.7.0.0 for the binding to intrinsically safe field busses Profibus PA respectively FF.H1.

The application of the supplemental types can occur in explosion-threatened areas, Which requires devices of the category 2. By the application in areas of explosion-threatened by dust, the at most allowed ambient temperature is +65°C.

By the application in areas explosion-threatened by gas is the maximum ambient temperature depending on the temperature class according to the following table:

Temperature classe	Ta
T6	Up to 45°C
T5	Up to 60°C

### Electrical data of the types D122.PA.7.0.0 and D122.FF.7.0.0

Signal and power supply circuit  
(terminal 1,3 and 2,4)

Ex- protection Intrinsically safe EEx ia IIC  
only to the connection in certified intrinsically safe circuits. Maximum ratings:

$$U_0 = 30 \text{ V}$$

$$I_0 = 660 \text{ mA}$$

$$P_0 = 1,6 \text{ W}$$

max reactances

$$L_0 = 0 \text{ } \mu\text{H}$$

$$C_0 = 0 \text{ nF}$$

The electrical data remains unchanged.

## 2. Amendment to the Conformity Certificate Nr. TÜV 99 ATEX 1488

---

The marking of the equipment:

 **II 2 (1) G EEx ia IIC T6 or T5; resp. II 2 D IP65 T70°C**

The marking of the further types remain unchanged.

The digital indicator type D122... according to the EC-type certificate TÜV 99 ATEX 1488 incl. 1. and this 2nd supplement also fulfils the demands of

EN 50 014 :1997 + A1+A2	General directives
EN 50 020:2002	Intrinsically safe "i"
EN 50 281-1-1:1998+A1	Electrical devices with protection by case - construction and check

All remaining data remain unchanged for this 2. Amendment.

The test documentation is listed in test report Nr. 04YEX551692

TÜV NORD CERT GmbH & Co. KG

Hannover, 03.11.2004

TÜV CERT-Zertifizierungsstelle  
Am TÜV 1  
0-30519 Hannover  
Tel.: 0511 986-1470  
Fax: 0511 986-2555

Der Leiter



### 3. Amendment

**to certification number:** TÜV 99 ATEX 1488

Device: Digital indicator type D122...  
 Manufacturer: Gönzheimer Elektronik GmbH  
 Dr.-Julius Leber-Str.2  
 Address: D-67433 Neustadt/Weinstraße  
 Germany  
 Order Number: 8000553381  
 Date of issue: 10.10.2006

**Changes:**

The digital indicator type D122 can also be manufactured according to the examination protocol, listed in the associated examination certificate. The change concerns the enlargement around the types D122.PA.7.0.3K and D122.FF.7.0.3K for the binding to intrinsically safe field busses Profibus PA respectively FF.H1 as a three channel indicator.

The application of the supplemental types can occur in explosion-threatened areas, which requires devices of the category 2. By the application in areas of explosion-threatened by dust, the at most allowed ambient temperature is +65°C.

The information to the allowed ambient temperature is valid consistently accordingly of the second supplement also for the supplemental types.

The electric data of the second supplement are changed as follows or complemented:

Electric data of the types D122. PA.7.0.0, D122.FF 7.0.0, D122. PA.7.0.3K and D122.FF.7.0.3K:

<p>Signal and power supply circuit (terminal 1,3 and 2,4)</p>	<p>By the application in by gas explosion-threatened areas in Ex protection Intrinsically safe EEx ia IIC.</p> <p>Field device FISCO to the connection with a device according to the FISCO model or</p> <p>Only to the connection in certified intrinsically safe circuits. Maximum ratings:</p> <p><math>U_0 = 30 \text{ V}</math>  <math>I_0 = 660 \text{ mA}</math>                  max reactances      <math>L_0 = 0 \text{ } \mu\text{H}</math>  <span style="margin-left: 150px;"><math>C_0 = 0 \text{ nF}</math></span></p> <p>By the application in by dust explosion-threatened areas max. limit input power</p> <p><math>P_0 = 1,6 \text{ W}</math></p>
---	---

The electrical data remains unchanged.



---

### 3. Amendment to the Conformity Certificate Nr. TÜV 99 ATEX 1488

---

The marking of the equipment:

 **II 2 (1) G EEx ia IIC T6 or T5; resp. II 2 D IP65 T70°C**

The marking of the further types remain unchanged.

The digital indicator type D122... according to the EC-type certificate TÜV 99 ATEX 1488 incl. 1. and this 2nd supplement also fulfils the demands of

EN 50 014 :1997 + A1+A2	General directives
EN 50 020:2002	Intrinsically safe "i"
EN 50 281-1-1:1998+A1	Electrical devices with protection by case - construction and check
DIN EN 60079-27:2006	Concept for intrinsically safe field bus systems (FISCO) and concept for non sparking field bus systems (FNICO)

The test documentation is listed in test report Nr. 06 YEX 553381.

(17) Special conditions for safe area

None

(18) Essential health and safety requirements

No additional

TÜV NORD CERT GmbH, Langemarckstraße 20, 45141 Essen, akkreditiert durch die Zentralstelle der Länder für Sicherheitstechnik (ZLS), Ident. Nr. 0044, Rechtsnachfolger der TÜV NORD CERT GmbH & Co. KG Ident. Nr. 0032

Der Leiter der Zertifizierungstelle

Schwedt

Geschäftsstelle Hannover, Am TÜV 1, 30519 Hannover, Tel.: +49 (0) 511 986-1455, Fax: +49 (0) 511 986-1590



## (1) **EG-Baumusterprüfbescheinigung**

- (2) Geräte und Schutzsysteme zur bestimmungsgemäßen Verwendung in explosionsgefährdeten Bereichen - **Richtlinie 94/9/EG**
- (3) EG Baumusterprüfbescheinigungsnummer



### **TÜV 99 ATEX 1488**

- (4) Gerät: Digitales Anzeigergerät Typ D122...
- (5) Hersteller: Gönzheimer Elektronik GmbH
- (6) Anschrift: D-67433 Neustadt/Weinstraße, Dr.-Julius Leber-Str.2
- (7) Die Bauart dieses Gerätes sowie die verschiedenen zulässigen Ausführungen sind in der Anlage zu dieser Baumusterprüfbescheinigung festgelegt.
- (8) Der TÜV Hannover/Sachsen-Anhalt e.V., TÜV CERT-Zertifizierungsstelle, bescheinigt als benannte Stelle Nr. 0032 nach Artikel 9 der Richtlinie des Rates der Europäischen Gemeinschaften vom 23. März 1994 (94/9/EG) die Erfüllung der grundlegenden Sicherheits- und Gesundheitsanforderungen für die Konzeption und den Bau von Geräten und Schutzsystemen zur bestimmungsgemäßen Verwendung in explosionsgefährdeten Bereichen gemäß Anhang II der Richtlinie.

Die Ergebnisse der Prüfung sind in dem vertraulichen Prüfbericht Nr. 99/PX24090 festgelegt.

- (9) Die grundlegenden Sicherheits- und Gesundheitsanforderungen werden erfüllt durch Übereinstimmung mit

**EN 50 014:1997      EN 50 020:1994      EN 50 028:1988**

- (10) Falls das Zeichen "X" hinter der Bescheinigungsnummer steht, wird auf besondere Bedingungen für die sichere Anwendung des Gerätes in der Anlage zu dieser Bescheinigung hingewiesen.
- (11) Diese EG-Baumusterprüfbescheinigung bezieht sich nur auf die Konzeption und den Bau des festgelegten Gerätes gemäß Richtlinie 94/9/EG. Weitere Anforderungen dieser Richtlinie gelten für die Herstellung und das Inverkehrbringen dieses Gerätes.
- (12) Die Kennzeichnung des Gerätes muß die folgenden Angaben enthalten:

 **II 2 (1) G EEx ia IIC T6 bzw. EEx m [ib] IIC T6**

TÜV Hannover/Sachsen-Anhalt e.V.  
TÜV CERT-Zertifizierungsstelle  
Am TÜV 1  
D-30519 Hannover

Hannover, 02.11.1999

Der Leiter



(13) **A N L A G E**

(14) **EG-Baumusterprüfbescheinigung Nr. TÜV 99 ATEX 1488**

(15) Beschreibung des Gerätes

Das digitale Anzeigegerät Typ D122... dient zur Anzeige von Messwerten aus eigensicheren 4-20 mA Stromkreisen innerhalb des explosionsgefährdeten Bereiches.

Der höchstzulässigen Umgebungstemperaturen betragen 45°C für die Temperaturklasse T6 und 60°C für die Temperaturklasse T5.

Elektrische Daten

Versorgungs- und  
Signalstromkreis  
(Klemme 1, 2)

in Zündschutzart Eigensicherheit EEx ia IIC bzw. EEx ib IIC  
nur zum Anschluss an bescheinigte eigensichere  
Stromkreise mit folgenden Höchstwerten:

$$U_i = 65 \text{ V}$$

$$I_i = 160 \text{ mA}$$

wirksame innere Kapazität	10	nF
wirksame innere Induktivität	40	μH

**nur Typ D122.T.x.x.x**

Versorgungs- und  
Signalstromkreis  
(Klemme 1, 2)

in Zündschutzart Eigensicherheit EEx ia IIC bzw. EEx ib IIC  
nur zum Anschluss an bescheinigte eigensichere  
Stromkreise mit folgenden Höchstwerten:

$$U_i = 30 \text{ V}$$

$$I_i = 160 \text{ mA}$$

$$P_i = 1,6 \text{ W}$$

wirksame innere Kapazität	10	nF
wirksame innere Induktivität	40	μH

Klemme 3, 4

gebrückt

**nur Typ D122.x.x.x.BM mit zusätzlicher Zündschutzart Vergusskapselung und der Kennzeichnung EEx m [ib] IIC T6 bzw. EEx m [ib] IIC T5**

Eingangstromkreis  
(Kabelschwanz)

$U_m = 250 \text{ V}$  und zum Anschluss an den  
Potenzialausgleich



### alle Typen

Grenzwertstromkreise  
(Klemme 5, 6; 7, 8) in Zündschutzart Eigensicherheit EEx ib IIC  
nur zum Anschluss an bescheinigte eigensichere  
Stromkreise mit folgenden Höchstwerten:

für Schaltausgänge

$U_i = 30 \text{ V}$   
 $I_i = 160 \text{ mA}$   
 $P_i = 850 \text{ mW}$   
 $U_i = 30 \text{ V}$

bzw. für Schalteingänge

wirksame innere Induktivität  $40 \mu\text{H}$   
die wirksame innere Kapazität ist vernachlässigbar klein

Alle eigensicheren Stromkreise sind voneinander bis zu einem Scheitelwert der Nennspannung von 90 V sicher galvanisch getrennt. Beim Typ D122.x.x.x.BM ist der Eingangstromkreis intern mit dem Versorgungs- und Signalstromkreis verbunden.

(16) Prüfungsunterlagen sind im Prüfbericht Nr.: 99/PX24090 aufgelistet.

(17) Besondere Bedingung

keine

(18) Grundlegende Sicherheits- und Gesundheitsanforderungen

keine zusätzlichen



**1. E R G Ä N Z U N G**  
zur  
**EG-Baumusterprüfbescheinigung Nr. TÜV 99 ATEX 1488**

der Firma: Gönzheimer Elektronik GmbH  
Dr.-Julius Leber-Str. 2  
D-67433 Neustadt/Weinstraße

Das digitale Anzeigegerät Typ D122... darf künftig entsprechend den im Prüfbericht aufgelisteten Unterlagen gefertigt und betrieben werden.

Die Änderungen betreffen die Erweiterung um den Typ D122.x.7.x.x. und den Einsatz dieses Typs in durch Staub explosionsgefährdeten Bereichen bis zu Umgebungstemperaturen von 65°C. Die Kennzeichnung dafür lautet:

**II 2 D IP 65 T70°C**

mit den Prüfgrundlagen: EN 50281-1-1:1999

Die elektrischen Daten und alle weiteren Angaben gelten unverändert für diese Ergänzung.

Prüfungsunterlagen sind im Prüfprotokoll Nr. 04 YEX 551248 aufgelistet.

TÜV NORD CERT GmbH & Co. KG  
TÜV CERT-Zertifizierungsstelle  
Am TÜV 1  
D-30519 Hannover  
Tel.: 0511 986-1470  
Fax: 0511 986-2555

Hannover, 17.02.2004

Der Leiter



## 2. ERGÄNZUNG zur EG-Baumusterprüfbescheinigung Nr. TÜV 99 ATEX 1488

der Firma: Gönzheimer Elektronik GmbH  
Dr. Julius Leber-Straße 2  
67433 Neustadt / Weinstraße

Das digitale Anzeigegerät darf künftig auch entsprechend der im Prüfbericht aufgeführten Prüfungsunterlagen gefertigt werden. Die Änderung betrifft die Erweiterung um die Typen D122.PA.7.0.0. und D122.FF.7.0.0. für die Anbindung an eigensichere Feldbusse Profibus PA bzw. FF.H1.

Der Einsatz der ergänzten Typen kann in explosionsgefährdeten Bereichen erfolgen, die Betriebsmittel der Kategorie 2 erfordern. Beim Einsatz in durch Staub explosionsgefährdeten Bereichen beträgt die maximal zulässige Umgebungstemperatur +65°C.

Beim Einsatz in durch Gas explosionsgefährdeten Bereichen ist die maximale Umgebungstemperatur abhängig von der Temperaturklasse der folgenden Tabelle zu entnehmen:

Temperaturklasse	T <sub>a</sub>
T6	bis 45°C
T5	bis 60°C

### Elektrische Daten der Typen D122.PA.7.0.0. und D122.FF.7.0.0.

Signal- und Versorgungsstromkreis (Klemme 1,3 und 2,4)	in Zündschutzart Eigensicherheit EEx ia IIC nur zum Anschluss an bescheinigte eigensichere Stromkreise Höchstwerte: $U_i = 30V$ $I_i = 660mA$ $P_i = 1,6 W$ wirksame innere Induktivität $L_i = 0 \mu H$ wirksame innere Kapazität $C_i = 0 nF$
---	---

Die elektrischen Daten der weiteren Typen gelten unverändert.

## 2. Ergänzung zur EG-Baumusterprüfbescheinigung Nr. TÜV 99 ATEX 1488

---

Kennzeichnung des Prüfgegenstandes:

 II 2(1) G EEx ia IIC T6 bzw. T5 bzw. II 2 D IP 65 T70°C

Die Kennzeichnung der weiteren Typen gilt unverändert.

Das digitale Anzeigegerät Typ D122... gemäß der EG-Baumusterprüfbescheinigung TÜV 99 ATEX 1488 incl. der 1. und dieser 2. Ergänzung erfüllt auch die Anforderungen der

EN 50 014:1997 +A1+A2	Allgemeine Bestimmungen
EN 50 020:2002	Eigensicherheit "i"
EN 50 281-1-1:1998+A1	Elektrische Betriebsmittel mit Schutz durch Gehäuse - Konstruktion und Prüfung

Alle übrigen Angaben gelten unverändert für diese 2. Ergänzung.

Die Prüfungsunterlagen sind im Prüfbericht Nr. 04 YEX 551692 aufgelistet.

TÜV NORD CERT GmbH & Co. KG  
TÜV CERT-Zertifizierungsstelle  
Am TÜV 1  
D-30519 Hannover  
Tel.: 0511 986-1470  
Fax: 0511 986-2555

Hannover, 03.11.2004



Der Leiter

### 3. ERGÄNZUNG

zur Bescheinigungsnummer: **TÜV 99 ATEX 1488**  
 Gerät: Digitales Anzeigegerät Typ D122...  
 Hersteller: Gönzheimer Electronic GmbH  
 Dr. – Julius Leber Straße 2  
 Anschrift: 67433 Neustadt / Weinstraße  
 Deutschland  
 Auftragsnummer: 8000553381  
 Ausstellungsdatum: 10.10.2006

#### Änderungen:

Das digitale Anzeigegerät darf künftig auch entsprechend der im Prüfbericht aufgeführten Prüfungsunterlagen gefertigt werden. Die Änderung betrifft die Erweiterung um die Typen D122.PA.7.0.3K und D122.FF.7.0.3K für die Anbindung an eigensichere Feldbusse Profibus PA bzw. FF.H1 als 3-kanaliger Anzeiger.

Der Einsatz der ergänzten Typen kann in durch Gas oder Staub explosionsgefährdeten Bereichen erfolgen, die Betriebsmittel der Kategorie 2 erfordern.

Die Angaben zur zulässigen Umgebungstemperatur gelten unverändert entsprechend der zweiten Ergänzung auch für die ergänzten Typen.

Die elektrischen Daten der zweiten Ergänzung werden wie folgt geändert bzw. ergänzt:

Elektrische Daten der Typen D122.PA.7.0.0, D122.FF.7.0.0, D122.PA.7.0.3K und D122.FF.7.0.3K:

Signal- und Versorgungsstromkreis (Klemme 1,3 und 2,4)	<p>Beim Einsatz in durch Gas explosionsgefährdete Bereiche in Zündschutzart Eigensicherheit EEx ia IIC.</p> <p>FISCO-Feldgerät zum Anschluss an ein Gerät entsprechend dem FISCO-Modell oder zum Anschluss an bescheinigte eigensichere Stromkreise.</p> <p>Höchstwerte:  <math>U_i = 30V</math>  <math>I_i = 660mA</math></p> <p>wirksame innere Induktivität <math>L_i = 0 \mu H</math>          wirksame innere Kapazität <math>C_i = 0 nF</math></p> <p>Beim Einsatz in durch Staub explosionsgefährdete Bereiche ist die max. Eingangsleistung zu begrenzen</p> <p><math>P_i = 1,6W</math></p>
---	---

Die elektrischen Daten der weiteren Typen gelten unverändert.

3. Ergänzung zur Bescheinigungsnummer TÜV 99 ATEX 1488

---

Kennzeichnung des Prüfgegenstandes:

 II 2(1) G EEx ia IIC T6 bzw. T5 bzw. II 2 D IP 65 T70°C

Die Kennzeichnung der weiteren Typen gilt unverändert.

Das digitale Anzeigegerät Typ D122... gemäß der EG-Baumusterprüfbescheinigung TÜV 99 ATEX 1488 incl. der 1. bis 3. Ergänzung erfüllt die Anforderungen der

EN 50 014:1997 +A1+A2	Allgemeine Bestimmungen
EN 50 020:2002	Eigensicherheit "i"
EN 50 281-1-1:1998+A1	Elektrische Betriebsmittel mit Schutz durch Gehäuse - Konstruktion und Prüfung
DIN EN 60079-27:2006	Konzept für eigensichere Feldbussystemw (FISCO) und Konzept für nichtzündfähige Feldbussysteme (FNICO)

Die Prüfungsunterlagen sind im Prüfbericht Nr. 06 YEX 553381 aufgelistet.

(17) Besondere Bedingungen

keine

(18) Grundlegende Sicherheits- und Gesundheitsanforderungen

keine zusätzlichen

TÜV NORD CERT GmbH, Langemarckstraße 20, 45141 Essen, akkreditiert durch die Zentralstelle der Länder für Sicherheitstechnik (ZLS), Ident. Nr. 0044, Rechtsnachfolger der TÜV NORD CERT GmbH & Co. KG Ident. Nr. 0032

Der Leiter der Zertifizierungsstelle



Schwedt

Geschäftsstelle Hannover, Am TÜV 1, 30519 Hannover, Tel.: +49 (0) 511 986-1455, Fax: +49 (0) 511 986-1590

# EG-Konformitätserklärung

Declaration of conformity / Déclaration de conformité

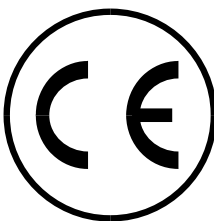

Communauté Européenne

Anbieter: Supplier: Fournisseur	Gönzheimer Elektronik GmbH
---------------------------------------	----------------------------

Anschrift: Address: Adresse:	Gewerbegebiet Nachtweide Dr.-Julius-Leber-Straße 2 67433 Neustadt/Weinstraße
------------------------------------	--

Produkt: Product: Produit:	D122, Anzeigegerät /Zähler
----------------------------------	-------------------------------

Das oben beschriebene Produkt erfüllt die Schutzanforderungen der folgenden EG-Richtlinien / the product described above complies with the following EG- rules / le produit décrit ci-dessus accomplit CU- réglementations

**2004/108/EG, 93/68/EWG, 94/9/EG**

und ist konform mit / and is in conformity with / et est conforme á:

DIN EN 60079-0: 2010, Allgemeine Bestimmungen DIN EN 60079-11: 2007, Eigensicherheit „i“ DIN EN 60079-18: 2005, Vergusskapselung „m“ DIN EN 61241-1: 2005, Schutz durch Gehäuse "tD" DIN EN 60079-27: 2006, Feldbussysteme FISCO + FNICO EN 61000-6-4: Fachgrundnorm Störaussendung; Teil 6-4: Industriebereich EN 61000-6-2: Fachgrundnorm Störfestigkeit; Teil 6-2: Industriebereich EN 60947-1: Niederspannungs-Schaltgeräte
--

zusätzliche Angaben / additional information / informations supplémentaires:

Qualitätsmanagement- System nach ISO EN DIN 9001:2008 Anerkanntes Qualitätssicherungssystem nach Richtlinie 94/9/EG
--

EG- Baumusterprüfbescheinigung / EC- Type certification / Attestation d'examen ce de type

TÜV 99 ATEX 1488
------------------

Diese Konformitätserklärung ist gültig für alle Produkte, die ab dem Datum der Unterzeichnung in Verkehr gebracht werden

Neustadt, den 11.03.2010

Gönzheimer (Geschäftsführer)