

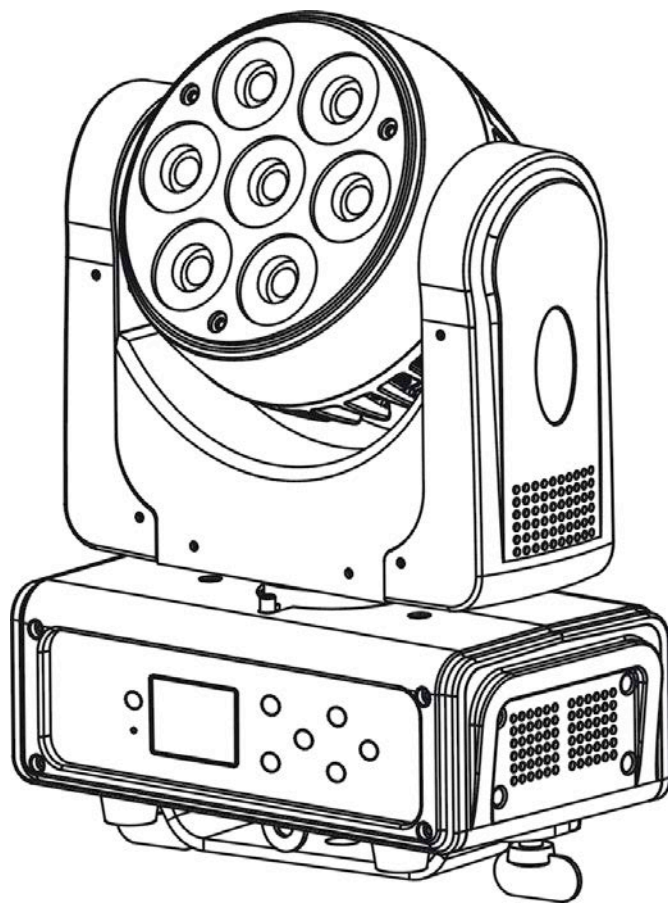

## **PROFESSIONAL MOVING HEAD USER MANUAL**



# WALLY-OK7Q

KEEP THIS MANUAL FOR FUTURE NEEDS





# Contents

1. Features .....	2
2. Fixture Overview .....	3
3. SAFETY INSTRUCTIONS .....	3
3.1) Important safety warns.....	3
3.2) GENERAL GUIDELINES .....	4
4. INSTALLATION INSTRUCTIONS .....	5
4.1) Mounting the device .....	5
5. DMX-512 control connection.....	8
6. DMX-512 connection with DMX terminator .....	9
7. Projector DMX start address selection.....	9
8. Control Board .....	10
8.1 <i>FUNCTION</i> .....	12
8.1.1 Set DMX Address .....	12
8.1.2 Dmx Value .....	12
8.1.3 Slave Mode .....	12
8.1.4 Auto Program.....	12
8.1.5 Sound Control.....	13
8.2 <i>Information</i> .....	13
8.2.1 Time information .....	13
8.2.2 Temperature Info.....	14
8.2.3 Software Ver.....	14
8.3 <i>PERSONALITY</i> .....	15
8.3.1 Status settings.....	15
8.3.2 Service setting.....	17
8.3.3 Fans Control.....	17
8.3.4 Display setting .....	18
8.3.5 Temperature C/F .....	18
8.3.6 Initial Status .....	19
8.3.7 Reset Default .....	19
8.4 <i>Reset Function</i> .....	19
8.5 <i>Effect Adjust</i> .....	19
8.5.1 Test channel.....	19
8.5.2 Manual control.....	20
8.5.3 Calibration.....	20
8.6 <i>Users mode set</i> .....	20
8.6.1 User mode .....	20
8.6.2 Edit User Mode .....	20
8.7 <i>Edit pro</i> .....	20
8.7.1 Select programs.....	20
8.7.2 Edit program .....	21
8.7.3 Edit scenes .....	21
8.7.4 Rec. Controller .....	21
9. INSTRUCTIONS ON USE .....	23
10. ERROR MESSAGE .....	25
11. CLEANING AND MAINTENANCE .....	26
12. TECHNICAL SPECIFICATIONS .....	27

Thank you for your patronage. We are confident that our excellent products and service can satisfy you. For your own safety, please read this user manual carefully before installing the device.

In order to install, operate, and maintain the lighting safely and correctly. We suggest that the installation and operation should be done by the verified technician and follow the instruction strictly.

	<b>CAUTION!</b> Keep this device away from rain and moisture !
	<b>CAUTION!</b> Unplug mains lead before opening the housing.

Every person involved with the installation, operation and maintenance of this device has to:  
-be qualified  
-follow carefully the instructions of this manual

### **INTRODUCTION:**

Thank you for having chosen this professional moving head.  
You will see you have acquired a powerful and versatile device.

Unpack the device. Inside the box you should find:

1. One XLR connection cable
2. Two omega clamps
3. One safety rope
4. Manual

Please check carefully that there is no damage caused by transportation. Should there be any, consult your dealer and don't install this device.

## **1. Features**

- 7 x 10W high power LEDs
- Extremely Long Life:100,000 Hr and low power consumption
- 3 DMX channel mode: 15/17/21 channels
- Pan/tilt movement: 8 bit and 16 bit resolution
  - For smooth and precise resolution
  - Pan: 540°/630° optional, Tilt: 265°movement
  - High speed of pan/tilt movement, speed of pan/tilt movement is adjustable
  - Scan position memory, auto reposition after unexpected movement
- Strobe effect with 18 flashes per second and pulse effect
- General dimming and blackout for all four colors
- Excellent color mixing and rainbow effect
- Display: Can be changed 180° reverse to fit for different installation position.
- Dimmer intensity from 0%~100%
- Control board with full color LCD graphic display and touch-keyboard
- Rechargeable Back up Battery for Display
- Preset program: 7 built in programs can be called up via DMX controller
  - Software-upload by optional accessory via DMX line

## 2. Fixture Overview

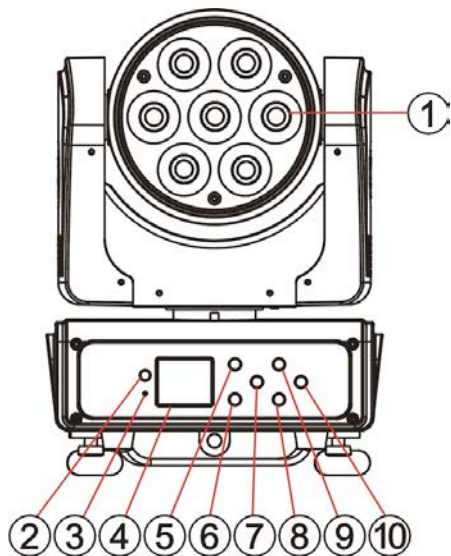

- 1: Lens
- 2: DC Switch
- 3: Microphone
- 4: Display
- 5: Mode/Esc-button
- 6: ENTER-button
- 7: Left-button
- 8: Down-button
- 9: Up-button
- 10: Right-button

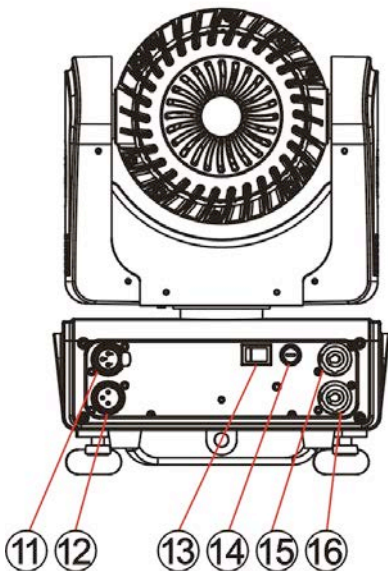

- 11: 3-Pin DMX out
- 12: 3-Pin DMX in
- 13: Power switch
- 14: Fuse
- 15: Power in
- 16: Power out

## 3. SAFETY INSTRUCTIONS

### 3.1) Important safety warns

	<p><b>CAUTION!</b> Be careful with your operations. With a dangerous voltage you can Suffer a dangerous electric shock when touching wires!</p>
---	---

This device has left the factory in perfect condition. In order to maintain this condition and to ensure a safe operation, it is absolutely necessary for the user to follow the safety instructions and warning notes written in this user manual.

**Important:**  
 *Damages caused by the disregard of this user manual are not subject to warranty. The dealer will not accept liability for any resulting defects or problems.*

If the device has been exposed to temperature changes due to environmental changes, do not switch it on immediately. The arising condensation could damage the device. Leave the device switched off until it has reached room temperature.

This device falls under protection-class I. Therefore it is essential that the device be earthed. If protection screen, lens or ultraviolet screen in the fixture is apparently damaged or is damaged to exceed their own effective degree, such as cracked and gashed, it must be replaced.

The electric connection must carry out by qualified person.

Make sure that the available voltage is not higher than stated at the end of this manual.



Make sure the power cord is never crimped or damaged by sharp edges. If this would be the case, replacement of the cable must be done by an authorized dealer.

Always disconnect from the mains, when the device is not in use or before cleaning it. Only handle the power cord by the plug. Never pull out the plug by tugging the power cord.

During initial start-up some smoke or smell may arise. This is a normal process and does not necessarily mean that the device is defective, it should decrease gradually.

Please don't project the beam onto combustible substances.

If the external flexible cable or cord of this luminaire is damaged, it shall be exclusively replaced by the manufacturer or his service agent or a similar qualified person in order to avoid a hazard.

	<b>CAUTION!</b> Never touch the device during operation! The housing may heat up
	<b>CAUTION!</b> Never look directly into the light source, as sensitive persons may suffer an epileptic shock.

**Please be aware that damages caused by manual modifications to the device are not subject to warranty. Keep away from children and non-professionals.**

### 3.2) GENERAL GUIDELINES

This device is a lighting effect for professional use on stages, in discotheques, theatres, etc., the device was designed for indoor use only.

This fixture is only allowed to be operated with the max alternating current which stated in the technical specifications in the last page of this manual.

Lighting effects are not designed for permanent operation. Consistent operation breaks may ensure that the device will serve you for a long time without defects.

Do not shake the device. Avoid brute force when installing or operating the device.

While choosing the installation-spot, please make sure that the device is not exposed to extreme heat, moisture or dust. Please don't project the beam onto combustible substances. The minimum distance between light-output from the projector and the illuminated surface must be more than 0.2 meter.

If you use the quick lock cam in hanging up the fixture, please make sure the quick lock fasteners turned in the quick lock holes correctly.

Operate the device only after having familiarized with its functions. Do not permit operation by persons not qualified for operating the device. Most damages are the result of unprofessional operation.

Please use the original packaging if the device is to be transported.

For safety reasons, please be aware that all modifications on the device are forbidden.

If this device will be operated in any way different to the one described in this manual, the product may suffer damages and the guarantee becomes void. Furthermore, any other operation may lead to short-circuit, burns, electric shock, lamp explosion, crash, etc.

## 4. INSTALLATION INSTRUCTIONS



### CAUTION!

Do not operate this device with open cover

### 4.1) Mounting the device



### CAUTION!

Please consider the GB7000.1-2007, GB7000.217-2008 and the other respective national norms during the installation. The installation must only be carried out by a qualified person.

The applicable temperature for the lighting is between -10°C to 45°C. Do not use the lighting under or above the temperature.

The installation of the effect has to be built and constructed in a way that it can hold 10 times the weight for 1 hour without any harming deformation.

The installation must always be secured with a secondary safety attachment, e.g. an appropriate safety rope.

Never stand directly below the device when mounting, removing or servicing the fixture.

The operator has to make sure the safety relating and machine technical installations are approved by an expert before taking the device into operation for the first time.

These installations have to be approved by a skilled person once a year.

Overhead mounting requires extensive experience, including amongst others calculating working load limits, installation material being used, and periodic safety inspection of all installation material and the device. If you lack these qualifications, do not attempt the installation yourself. Improper installation can result in bodily injury.



## CAUTION!

The electric connection must only be carried out by a qualified electrician.

Before mounting make sure that the installation area can hold a minimum point load of 10 times the device's weight.

Connect the fixture to the mains with the power plug.

### Installation via the Omega holders

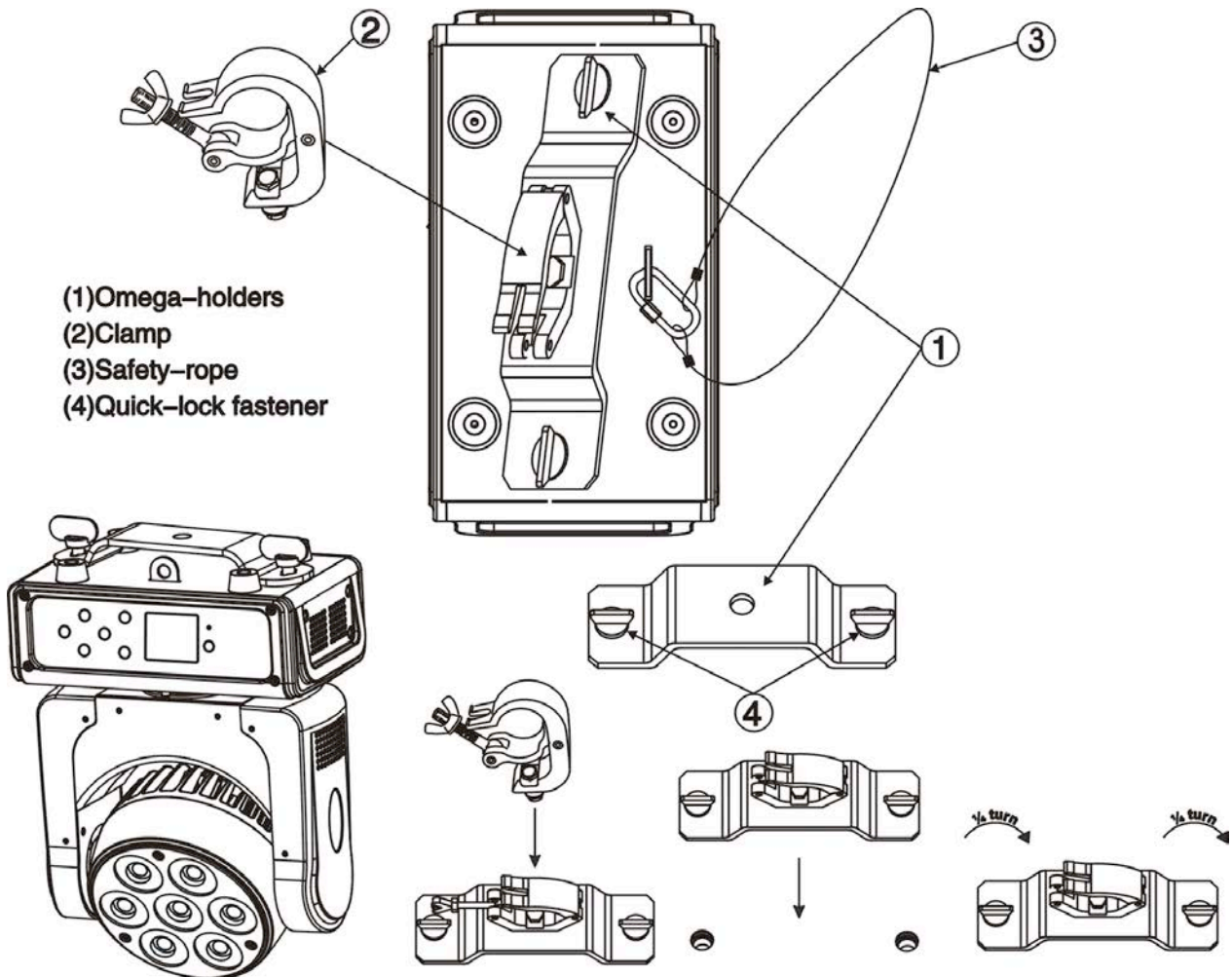

- Fixed the clamp on the bracket by tighten up the M12 screw on the bracket to the  $\Phi 13$  hole in the middle of the bracket.
- Insert the quick-lock fasteners of the first Omega holder into the respective holes on the bottom of the device. Tighten the quick-lock fasteners fully clockwise.
- Install the second Omega holder.
- Pull the safety-rope through the holes on the bottom of the base and over the trussing system or a safe fixation spot. Insert the end in the carabine and tighten the safety screw.

**Notice: this step is quite important to ensure that the fixture will not drop out by the damage of the clamp.**



**Dimensional Drawings:**

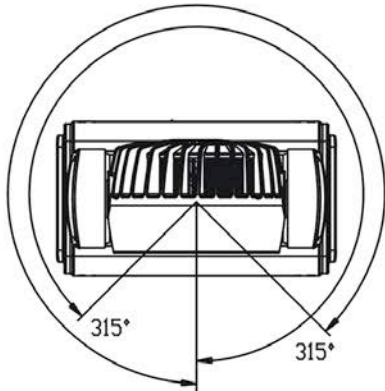
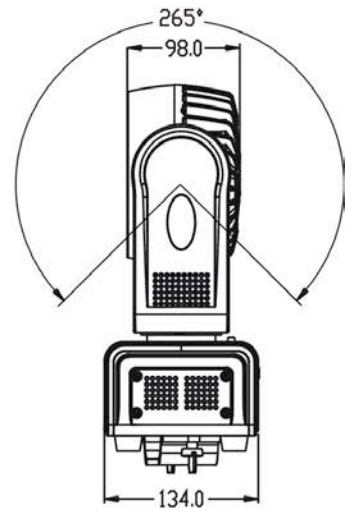
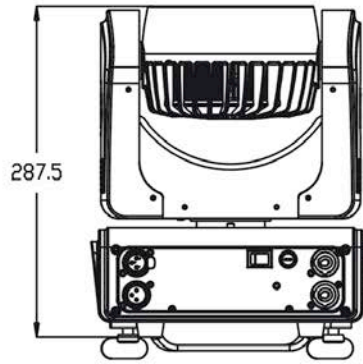
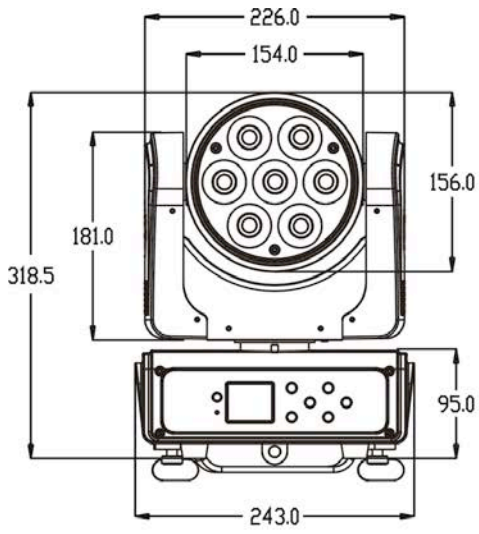



## Layout Drawings:

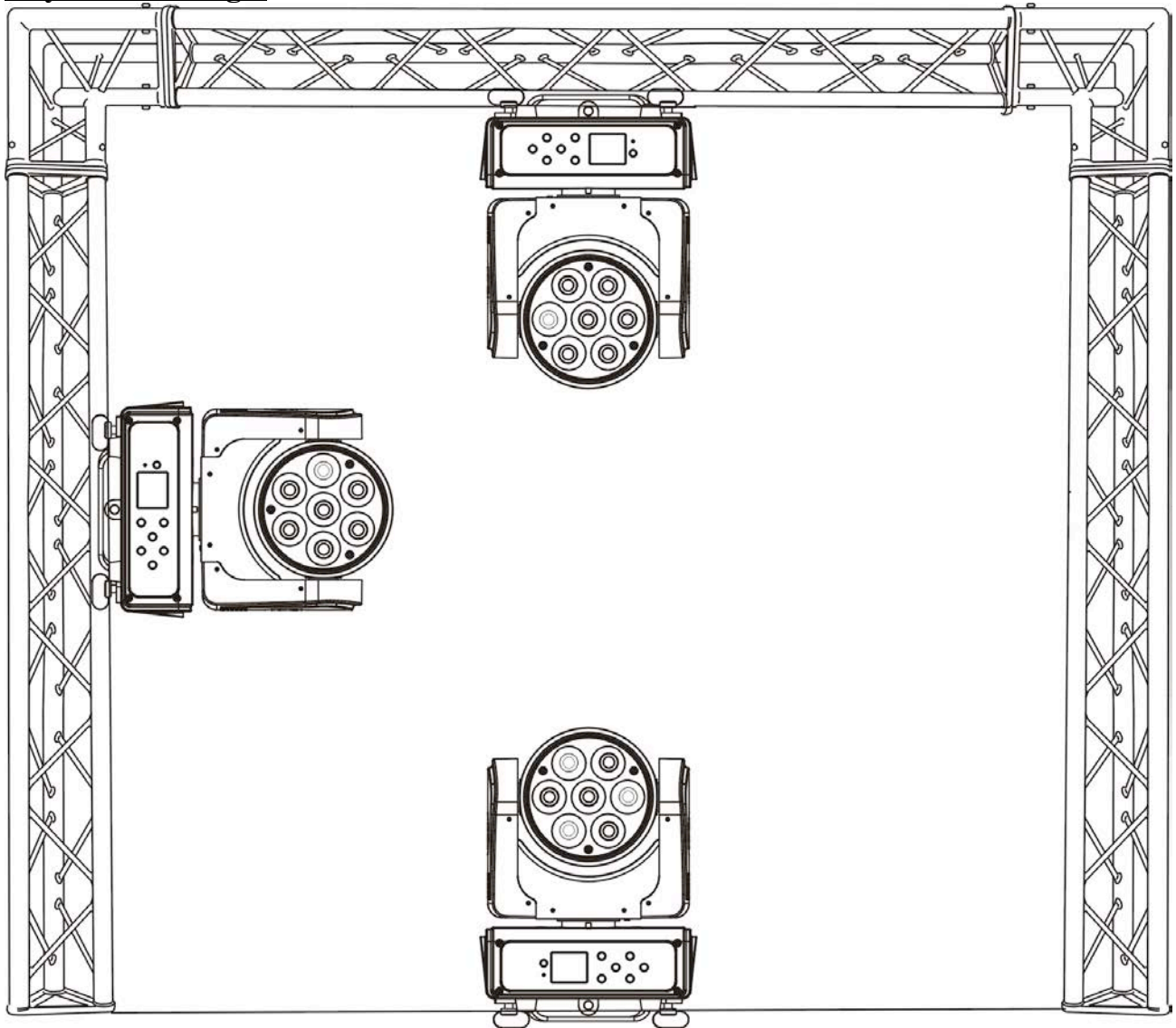

### Mounting points

Be sure this fixture is kept at least 0.2m away from any flammable materials (decoration etc.). Always use and install the supplied safety cable as a safety measure to prevent accidental damage and/or injury in the event the clamp fails.

Overhead mounting requires extensive experience, including amongst others calculating working load limits, a fine knowledge of the installation material being used, and periodic safety inspection of all installation material and the fixture. If you lack these qualifications, do not attempt the installation yourself. Improper installation can result in bodily injury.

### 5. DMX-512 control connection

Connect the provided XLR cable to the female 3-pin XLR output of your controller and the other side to the male 3-pin XLR input of the moving head. You can chain multiple Moving head together through serial linking. The cable needed should be two core, screened cable with XLR input and output connectors. Please refer to the diagram below.

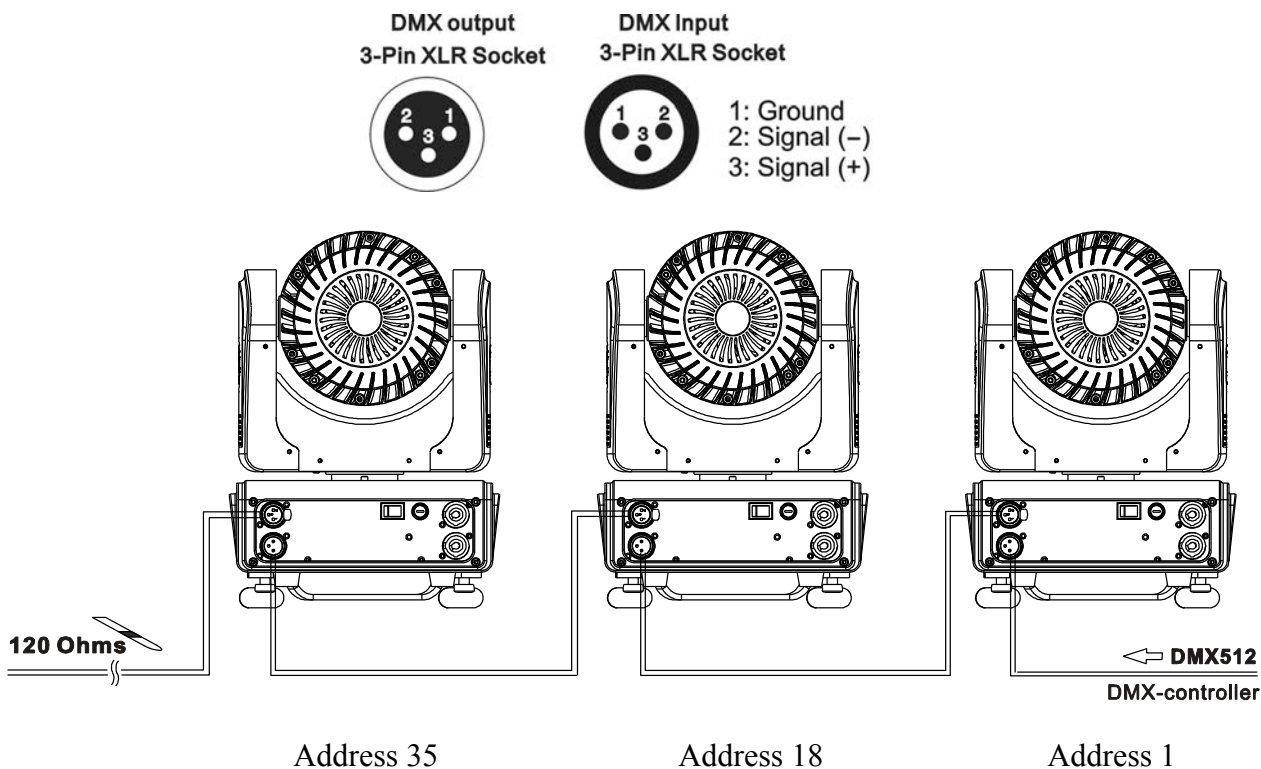

**Please note:** to ensure maximal stability, when the voltage is 120V, only five devices may be connected together in this manner! From the sixth device, please connect to power supply to get power for the second link; when the voltage is over 220V, only ten devices may be connected together in this manner! From the eleventh device, please connect to power supply to get power for the second link.

## 6. DMX-512 connection with DMX terminator

For installations where the DMX cable has to run a long distance or is in an electrically noisy environment, such as in a discotheque, it is recommended to use a DMX terminator. This helps in preventing corruption of the digital control signal by electrical noise. The DMX terminator is simply an XLR plug with a 120 Ω resistor connected between pins 2 and 3, which is then plugged into the output XLR socket of the last fixture in the chain. Please see illustrations below.

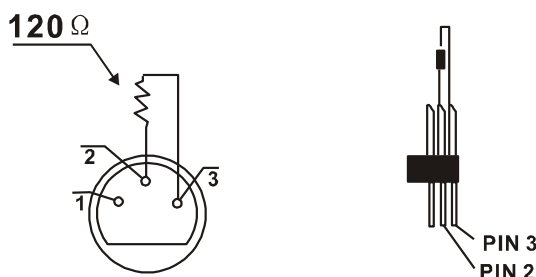

## 7. Projector DMX start address selection

All fixtures should be given a DMX starting address when using a DMX signal, so that the correct fixture responds to the correct control signals. This digital starting address is the channel number from which the fixture starts to “listen” to the digital control information sent out from the DMX controller. The allocation of this starting address is achieved by setting the correct number on the display located on the base of the device.

You can set the same starting address for all fixtures or a group of fixtures, or make different

address for each fixture individually.

If you set the same address, all the units will start to “listen” to the same control signal from the same channel number. In other words, changing the settings of one channel will affect all the fixtures simultaneously.





If you set a different address, each unit will start to “listen” to the channel number you have set, based on the quantity of control channels of the unit. That means changing the settings of one channel will affect only the selected fixture.





In the case of the led move head, which is a 17 channel fixture, you should set the starting address of the first unit to 1, the second unit to 18(17 + 1), the third unit to 35 (17+ 18), and so on.

## 8. Control Board

The Control Board offers several features: you can simply set the starting address , run the pre-programmed program or make a reset.

The main menu is accessed by pressing the  -button until the display starts flashing.

Browse through the menu by pressing the  -button ,  -button ,  -button or  -button. Press the Enter-button in order to select the desired menu. You can change the

selection by pressing the the  -button ,  -button ,  -button or  -button.

Confirm every selection by pressing the  -button. You can leave every mode by pressing the

 -button. The functions provided are described in the following sections. it will exit from flash 10 seconds after the last keypress. Press this key under edit mode, . The functions provided are described in the following sections.

**To access the display menu via the internal battery, press the DC switch button for 2seconds; To shut off the display immediately, choose the commend " Reset All" menu and press "Enter" button, otherwise, the display will automatically switch off about 1 minute from last button press.**

Function	Set Dmx Address	A001~AXXX		DMX address setting
	Dmx Value	ALL.....		DMX value display
	Slave Mode	Slave1,Slave2,Slave3		Slave setting
	Auto Program	Master / Alone		Auto program
	Sound Control	Master / Alone		Music control
Information	Time Information.	Current Time	XXXX(Hours)	Power on running time
		Total Run Time	XXXX(Hours)	Fixture running time
Last Run Time		XXXX(Hours)	Fixture Last times clear	
LastRun Password		Password=XXX	Timer Password 038	
Clean Last Run		ON/OFF	Clear Fixture Last time	
Temperature. Info	Head Temp.	XXX□/□	Temperature in the head	

	Software Ver	V1.0.....		Software version
Personality	Status Settings	Addr via DMX No DMX Mode Pan Reverse Tilt Reverse Pan Degree Feedback Movement Speed Mic Sensitivity. Hibernation	ON/OFF Close/Hold/Auto/Music ON/OFF ON/OFF 630/540 ON/OFF Speed 1~ 4 0~99% OFF, 01M~99M, 15M	Add. via DMX Auto run if no DMX Pan Reverse movement Tilt Reverse movement Pan Degree Select Movement Feedback Movement Mode Select Sensitivity of Mic. Stand by Mode
	Service Setting	Service Pass RDM PID	Password=XXX XXXXXX	Service Password“=050” RDM PID Code
	Fans Control	Auto High Low		Fans Speed select
	Display Setting	Shutoff Time Display Reverse Key Lock Disp Flash	02~60m 05m ON/OFF ON/OFF ON/OFF	Display shutoff time Reverse 180 degree Key Lock No Signal Flash
	Temperature C/F	Celsius Fahrenheit		Temperature switch between □/□
	Initial Status	PAN =XXX		Initial effect position
	Reset Default	ON/OFF		Restore factory set.
Reset Function	Reset Pan^Tilt			Reset Pan/Tilt
Effect Adjust	Test Channel	AUTO .....		Test function
	Manual Control	AUTO =XXX :		Fine adjustment of the lamp
	Calibration	Calibrate Password Color wheel=XXX :		Password “050” Calbrate and adjust the effects to standard/right position
User Mode Set	User Mode	Standard Mode Basic Mode Extended Mode User Mode A User Mode B User Mode C		User's mode to change channel numbers
	Edit User ModeA Edit User ModeB Edit User ModeC	Max Channel = XX PAN = CH01 :		Preset User modes
	Select Program	Prog. Part 1 = Program 1 ~ 10 Prog. Part 2 = Program 1 ~ 10 Prog. Part 3 = Program 1 ~ 10	Program 1 Program 2 Program 3	Select programs to be run

	Edit Program	Program 1 : Program 10	Program Test Step 01=SCxxx Step 64=SCxxx	Testing program Program in loop Save and exit
	Edit Scenes	Edit Scene 001 ~ Edit Scene 83	Pan,Tilt,..... --Fade Time-- --Secne Time-- Input By Out	Save and automatically return manual scenes edit
	Rec Controler	XX~XX		Automat. scenes rec

Default settings shaded

## 8.1 FUNCTION

### 8.1.1 Set DMX Address

With this function, you can adjust the desired DMX-address via the Control Board.

1. Access the main menu.
2. Tap the <Up/Down>button until “Set DMX Address” is displayed.
3. Press ENTER, the display will show “Set DMX Address” .
4. Tap the <Up/Down>button, the display will show “A001~AXXX”
5. Press ENTER to confirm or press <MODE/ESC> to return to the main menu.

### 8.1.2 Dmx Value

With this function you can display the DMX 512 value of each channel. The display automatically shows the channel with a value changing.

1. Access the main menu.
2. Tap the <Up/Down>button until “Dmx Value” is displayed.
3. Press ENTER, the display will show “Dmx Value” .
4. Tap the <Up/Down>button, choose each channel.
5. Press ENTER to confirm or press <MODE/ESC> to return to the main menu.

### 8.1.3 Slave Mode

With this function, you can define the device as slave.

1. Access the main menu.
2. Tap the <Up/Down>button until “Slave Mode” is displayed.
3. Press ENTER, the display will show “Slave Mode” .
4. Tap the <Up/Down>button, the display will show “Slave1”, ”Slave2”, ”Slave3”.
5. Press ENTER to confirm or press <MODE/ESC> to return to the main menu.

### 8.1.4 Auto Program

With this function, you can run the internal program. You can select the desired program under “**Select program**”. You can set the number of steps under “**Edit program**”. You can edit the individual scenes under “**Edit scenes**”. With this function, you can run the individual scenes either automatically, i.e. with the adjusted Step-Time.

1. Access the main menu.
2. Tap the <Up/Down>button until “Auto Program” is displayed.
3. Press ENTER, the display will show “Auto Program” .
4. Tap the <Up/Down>button, the display will show “Master1”, ”Alone”.
5. Press ENTER to confirm or press <MODE/ESC> to return to the main menu.

### 8.1.5 Sound Control

With this function, you can run the internal program sound-controlled.

1. Access the main menu.
2. Tap the <Up/Down>button until “Sound Control” is displayed.
3. Press <ENTER>, the display will show “Sound Control” .
4. Tap the <Up/Down>button, the display will show “Master1”, ” Alone”.
5. Press <ENTER> to confirm or press <MODE/ESC> to return to the main menu.

## 8.2 Information

### 8.2.1 Time information

#### Current Time

With this function, you can display the temporary running time of the device from the last power on. The display shows “XXXX”, “XXXX” stands for the number of hours. The counter is resetted after turning the device off.

1. Tap <MODE/ESC>button, access the main menu, Tap the <Up/Down>button until “Information” is displayed. Press ENTER, the display will show “Information” . Tap the <Up/Down>button until the display will show “Time Information” . Press ENTER, the display will show “Time Information” .
2. Press <Up/Down>, the display will show “Current Time” .
3. Press< ENTER>, the display will show “Current Time” .
4. The display will show “XXXX” (Hours) ;
5. Press <ENTER> to confirm or press <MODE/ESC> to return to the main menu.

#### Total Run Time

With this function, you can display the running time of the device. The display shows “XXXX”, “XXXX” stands for the number of hours.

1. Tap <MODE/ESC>button, access the main menu, Tap the <Up/Down>button until “Information” is displayed. Press ENTER, the display will show “Information” . Tap the <Up/Down>button until the display will show “Time Information” . Press ENTER, the display will show “Time Information” .
2. Press <Up/Down>, the display will show “Total Run Time” .
3. Press< ENTER>, the display will show “Total Run Time” .
4. The display will show “XXXX” (Hours) ;
5. Press <ENTER> to confirm or press <MODE/ESC> to return to the main menu.

#### Last Run Time

With this function, you can display last the running time of the lamp. The display shows “XXXX”, “XXXX” stands for the number of hours

1. Tap <MODE/ESC>button, access the main menu, Tap the <Up/Down>button until “Information” is displayed. Press ENTER, the display will show “Information” . Tap the <Up/Down>button until the display will show “Time Information” . Press ENTER, the display will show “Time Information” .
2. Press <Up/Down>, the display will show “Last Run Time” .
3. Press< ENTER>, the display will show “Last Run Time” .
4. The display will show “XXXX” (Hours) ;
5. Press <ENTER> to confirm or press <MODE/ESC> to return to the main menu.

### **LastRun Password**

With this function, you can display the timer password.

1. Tap <MODE/ESC>button, access the main menu, Tap the <Up/Down>button until “Information” is displayed. Press ENTER, the display will show “Information”. Tap the <Up/Down>button until the display will show “Time Information”. Press ENTER, the display will show “Time Information” .
2. Press <Up/Down>, the display will show “LastRun Password” .
3. Press< ENTER>, the display will show“LastRun Password”. The time password is 038.
4. Press <ENTER> to confirm or press <MODE/ESC> to return to the main menu.

### **Clean Last Run**

With this function, you can clear last run time of the fixture. The display shows “ON” or “OFF”, Press “Enter” to confirm.

1. Tap <MODE/ESC>button, access the main menu, Tap the <Up/Down>button until “Information” is displayed. Press ENTER, the display will show “Information”. Tap the <Up/Down>button until the display will show “Time Information”. Press ENTER, the display will show “Time Information” .
2. Press <Up/Down>, the display will show “Clean Last Run” .
3. At “L-Timer Password” menu input right password, Press< ENTER>, the display will show “Clean Last Run” .
4. The display show “OFF” ,Press <Up/Down>, the display will show “ON” .
5. Press <ENTER> to confirm or press <MODE/ESC> to return to the main menu.

## **8.2.2 Temperature Info**

### **Head Temp.**

With this function you can display the temperature on the display board of the base (near CMY-filter) in Celsius.

1. Tap <MODE/ESC>button, access the main menu, Tap the <Up/Down>button until “Information” is displayed. Press ENTER, the display will show “Information”. Tap the <Up/Down>button until “Temperature Info” is displayed. Press ENTER, the display will show “Temperature Info” .
2. Press <Up/Down>, the display will show “Head Temp.” .
3. Press< ENTER>, the display will show “Head Temp.” .
4. The display show “XXX ° C/ ° F”.
5. Press <ENTER> to confirm or press <MODE/ESC> to return to the main menu.

## **8.2.3 Software Ver**

With this function, you can display the software version of the device.

1. Tap <MODE/ESC>button, access the main menu, Tap the <Up/Down>button until “Information” is displayed. Press ENTER, the display will show “Information” .
2. Press <Up/Down>, the display will show “Software Ver” .
3. Press< ENTER>, the display will show “Software Ver” .
4. The display show “Ver x.x”.
5. Press <ENTER> to confirm or press <MODE/ESC> to return to the main menu.



## **8.3 PERSONALITY**

### **8.3.1 Status settings**

#### **Addr via DMX**

With this function, you can adjust the desired DMX-address via an external controller.

1. Tap <MODE/ESC>button, access the main menu, Tap the <Up/Down>button until “Personality” is displayed. Press ENTER, the display will show “Personality” . Tap the <Up/Down>button until the display will show “Status settings” . Press ENTER, the display will show “Status settings” .
2. Press <Up/Down>, the display will show “Address via DMX” .
3. Press< ENTER>, the display will show “Address via DMX” .
4. The display show “ON” ,Press <Up/Down>, the display will show “OFF” .
5. Press <ENTER> to confirm or press <MODE/ESC> to return to the main menu.

#### **No DMX Mode**

With this function, when the drive is not DMX signal, it runs automatism, close, hold and music, the default is hold.

1. Tap <MODE/ESC>button, access the main menu, Tap the <Up/Down>button until “Personality” is displayed. Press ENTER, the display will show “Personality” . Tap the <Up/Down>button until the display will show “Status settings” . Press ENTER, the display will show “Status settings” .
2. Press <Up/Down>, the display will show “No DMX Mode” .
3. Press< ENTER>, the display will show “No DMX Mode” .
4. The display show “Hold” ,Press <Up/Down>, the display will show “Close Shutter”, “Auto Program”, “Music Control”.
5. Press <ENTER> to confirm or press <MODE/ESC> to return to the main menu.

#### **Pan Reverse**

With this function you can reverse the Pan-movement.

1. Tap <MODE/ESC>button, access the main menu, Tap the <Up/Down>button until “Personality” is displayed. Press ENTER, the display will show “Personality” . Tap the <Up/Down>button until the display will show “Status settings” . Press ENTER, the display will show “Status settings” .
2. Press <Up/Down>, the display will show “Pan Reverse” .
3. Press< ENTER>, the display will show “Pan Reverse” .
4. The display show “OFF” ,Press <Up/Down>, the display will show “ON” .
5. Press <ENTER> to confirm or press <MODE/ESC> to return to the main menu.

#### **Tilt Reverse**

With this function you can reverse the Tilt-movement.

1. Tap <MODE/ESC>button, access the main menu, Tap the <Up/Down>button until “Personality” is displayed. Press ENTER, the display will show “Personality” . Tap the <Up/Down>button until the display will show “Status settings” . Press ENTER, the display will show “Status settings” .
2. Press <Up/Down>, the display will show “Tilt Reverse” .
3. Press< ENTER>, the display will show “Tilt Reverse” .
4. The display show “OFF” ,Press <Up/Down>, the display will show “ON” .
5. Press <ENTER> to confirm or press <MODE/ESC> to return to the main menu.

### **Pan Degree**

With this function, you can select pan degree for 630 or 540.

1. Tap <MODE/ESC>button, access the main menu, Tap the <Up/Down>button until “Personality” is displayed. Press ENTER, the display will show “Personality” . Tap the <Up/Down>button until the display will show “Status settings” . Press ENTER, the display will show “Status settings” .
2. Press <Up/Down>, the display will show “Pan Degree” .
3. Press< ENTER>, the display will show “Pan Degree” .
4. The display show “540” ,Press <Up/Down>, the display will show “630” .
5. Press <ENTER> to confirm or press <MODE/ESC> to return to the main menu.

### **Feedback**

With this function, you can feedback switch of pan movement or tilt movement.

1. Tap <MODE/ESC>button, access the main menu, Tap the <Up/Down>button until “Personality” is displayed. Press ENTER, the display will show “Personality” . Tap the <Up/Down>button until the display will show “Status settings” . Press ENTER, the display will show “Status settings” .
2. Press <Up/Down>, the display will show “Feedback” .
3. Press< ENTER>, the display will show “Feedback” .
4. The display show “ON” ,Press <Up/Down>, the display will show “OFF” .
5. Press <ENTER> to confirm or press <MODE/ESC> to return to the main menu.

### **Movement Speed**

With this function, you can select scan mode from 1 to 4.

1. Tap <MODE/ESC>button, access the main menu, Tap the <Up/Down>button until “Personality” is displayed. Press ENTER, the display will show “Personality” . Tap the <Up/Down>button until the display will show “Status settings” . Press ENTER, the display will show “Status settings” .
2. Press <Up/Down>, the display will show “Movement Speed” .
3. Press< ENTER>, the display will show “Movement Speed” .
4. The display show “Speed 1” ,Press <Up/Down>, the display will show “Speed 2”, “Speed 3”, “Speed 4”.
5. Press <ENTER> to confirm or press <MODE/ESC> to return to the main menu.

### **Mic Sensitivity**

With this function, the default is 70%, you can select the desired microphone sensitivity from 0 % to 99 %.

1. Tap <MODE/ESC>button, access the main menu, Tap the <Up/Down>button until “Personality” is displayed. Press ENTER, the display will show “Personality” . Tap the <Up/Down>button until the display will show “Status settings” . Press ENTER, the display will show “Status settings” .
2. Press <Up/Down>, the display will show “Mic Sensitivity” .
3. Press< ENTER>, the display will show “Mic Sensitivity” .
4. The display show “70%” ,Press <Up/Down>, the display will show “0~99%” .
5. Press <ENTER> to confirm or press <MODE/ESC> to return to the main menu.

### **Hibernation —Standby mode**

The lamp and step motors will be power off if the fixture stay without DMX signal for 15 mins (Factory default).And the fixture will be reset before working once it receive DMX signal again.

1. Tap <MODE/ESC>button, access the main menu, Tap the <Up/Down>button until “Personality” is displayed. Press ENTER, the display will show “Personality” . Tap the <Up/Down>button until the display will show “Status settings” . Press ENTER, the display will show “Status settings” .
2. Press <Up/Down>, the display will show “Hibernation” .
3. Press< ENTER>, the display will show “Hibernation” .
4. The display show “15M” ,Press <Up/Down>, the display will show “01M”, “02M” .... “99M” or “OFF” .
5. Press <ENTER> to confirm or press <MODE/ESC> to return to the main menu.

### **8.3.2 Service setting**

**Service Pass**——The Password for this function is “50”.

**RDM PID**—— With this function you can call up various submenus via RDM.

This device is RDM ready. RDM stands for "remote device management" and makes remote control of devices connected to the DMX-bus. ANSI E1.20-2006 by ESTA specifies the RDM standard as an extension of the DMX512 protocol.

Manual settings like adjusting the DMX starting address are no longer needed. This is especially useful when the device is installed in a remote area.

RDM ready and conventional DMX devices can be operated in one DMX line. The RDM protocol sends own packages in the DMX512 data feed and does not influence conventional devices.

If DMX splitters are used and RDM control is to be used, these splitters must support RDM.

The number and type of RDM parameters depend on the RDM controller being used.

### **8.3.3 Fans Control**

With this function, you can set the speed of the running fans. The selections have Auto、 high and low.

1. Tap <MODE/ESC>button, access the main menu, Tap the <Up/Down>button until “Personality” is displayed. Press ENTER, the display will show “Personality” .
2. Press <Up/Down>, the display will show “Fans Control” .
3. Press< ENTER>, the display will show “Fans Control” .
4. The display show “Auto” ,Press <Up/Down>, the display will show “High”, “Low”.
5. Press <ENTER> to confirm or press <MODE/ESC> to return to the main menu.

### 8.3.4 Display setting

#### Shut off time

With this function you can shut off the color LCD display after 2 to 59 minutes. Turn the encoder in order to select the desired shut off time. The default is 5 minute.

#### Display Reverse

With this function you can the entire display to be flipped by 180° to allow for better view when the fixture is hung from truss or a ceiling. This function is disabled as default.

1. Tap <MODE/ESC>button, access the main menu, Tap the <Up/Down>button until “Personality” is displayed. Press ENTER, the display will show “Personality” . Tap the <Up/Down>button until the display will show “Display Setting” . Press ENTER, the display will show “Display Setting” .
2. Press <Up/Down>, the display will show “Display Reverse” .
3. Press< ENTER>, the display will show “Display Reverse” .
4. The display show “OFF” ,Press <Up/Down>, the display will show “ON” .
5. Press <ENTER> to confirm or press <MODE/ESC> to return to the main menu.

#### Key Lock

With this function you can activate the automatic keylock status. If this function is activated, the keys will be locked automatically after exiting the edit mode for 15 seconds. keeping press the [MENU] key for 3seconds if you do not need this function.

1. Tap <MODE/ESC>button, access the main menu, Tap the <Up/Down>button until “Personality” is displayed. Press ENTER, the display will show “Personality” . Tap the <Up/Down>button until the display will show “Display Setting” . Press ENTER, the display will show “Display Setting” .
2. Press <Up/Down>, the display will show “Key Lock” .
3. Press< ENTER>, the display will show “Key Lock” .
4. The display show “OFF” ,Press <Up/Down>, the display will show “ON” .
5. Press <ENTER> to confirm or press <MODE/ESC> to return to the main menu.

#### Displ Flash

With this function you can the entire display to be flipped by 180° to allow for better view when the fixture is hung from truss or a ceiling. This function is disabled as default.

1. Tap <MODE/ESC>button, access the main menu, Tap the <Up/Down>button until “Personality” is displayed. Press ENTER, the display will show “Personality” . Tap the <Up/Down>button until the display will show “Display Setting” . Press ENTER, the display will show “Display Setting” .
2. Press <Up/Down>, the display will show “Display Reverse” .
3. Press< ENTER>, the display will show “Display Reverse” .
4. The display show “OFF” ,Press <Up/Down>, the display will show “ON” .
5. Press <ENTER> to confirm or press <MODE/ESC> to return to the main menu.

### 8.3.5 Temperature C/F

With this function, Display the temperature for Celsius or Fahrenheit.

1. Tap <MODE/ESC>button, access the main menu, Tap the <Up/Down>button until

- “Personality” is displayed. Press ENTER, the display will show “Personality” .
- 2. Press <Up/Down>, the display will show “Temperature C/F” .
- 3. Press< ENTER>, the display will show “Temperature C/F” .
- 4. The display show “Celsius” ,Press <Up/Down>, the display will show “Fahrenheit”.
- 5. Press <ENTER> to confirm or press <MODE/ESC> to return to the main menu.

### **8.3.6 Initial Status**

With this function, Display initial effect position.

- 1. Tap <MODE/ESC>button, access the main menu, Tap the <Up/Down>button until “Personality” is displayed. Press ENTER, the display will show “Personality” .
- 2. Press <Up/Down>, the display will show “Initial Status” .
- 3. Press< ENTER>, the display will show “Initial Status” .
- 4. The display show “XXX” .
- 5. Press <ENTER> to confirm or press <MODE/ESC> to return to the main menu.

### **8.3.7 Reset Default**

With this function, you can select restore factory set for ON or OFF, the default is OFF.

- 1. Tap <MODE/ESC>button, access the main menu, Tap the <Up/Down>button until “Personality” is displayed. Press ENTER, the display will show “Personality” .
- 2. Press <Up/Down>, the display will show “Reset Default” .
- 3. Press< ENTER>, the display will show “Reset Default” .
- 4. The display show “OFF” ,Press <Up/Down>, the display will show “ON”.
- 5. Press <ENTER> to confirm or press <MODE/ESC> to return to the main menu.

## **8.4 Reset Function**

With this function you can reset the device via the Control Board. You can select the different reset functions by turning the encoder.

- 1. Tap <MODE/ESC>button, access the main menu, Tap the <Up/Down>button until “Reset Function” is displayed. Press ENTER, the display will show “Reset Function” .
- 2. The display show “Reset Pan&Tilt” , Press <Up/Down>, the display will show “Reset Pan&Tilt” .
- 3. Press <ENTER> to confirm or press <MODE/ESC> to return to the main menu.

## **8.5 Effect Adjust**

### **8.5.1 Test channel**

With this function you can test each channel on its (correct) function.

- 1. Tap <MODE/ESC>button, access the main menu, Tap the <Up/Down>button until “Effect Adjust” is displayed. Press ENTER, the display will show “Effect Adjust” .
- 2. Press <Up/Down>, the display will show “Test Channel” .
- 3. Press< ENTER>, the display will show “Test Channel” .
- 4. The display show “AUTO Moving” frist channel, Press <Up/Down>, can choose other channel.

5. Press <ENTER> to confirm or press <MODE/ESC> to return to the main menu.

### **8.5.2 Manual control**

With this function, you can adjust the lamp more easily. All effects will be canceled, the shutter opens and the dimmer intensity will be set to 100 %. With the individual functions, you can focus the light on a flat surface (wall) and perform the fine lamp adjustment.

1. Tap <MODE/ESC>button, access the main menu, Tap the <Up/Down>button until “Effect Adjust” is displayed. Press ENTER, the display will show “Effect Adjust” .
2. Press <Up/Down>, the display will show “AUTO control” .
3. Press< ENTER>, the display will show “AUTO control” .
4. The display show “PAN=XXX” .
5. Press <ENTER> to confirm or press <MODE/ESC> to return to the main menu.

### **8.5.3 Calibration**

With this function, you can calibrate and adjust the effect wheels to their correct positions. The password of calibrate values is 050.

1. Tap <MODE/ESC>button, access the main menu, Tap the <Up/Down>button until “Effect Adjust” is displayed. Press ENTER, the display will show “Effect Adjust” .
2. Press <Up/Down>, the display will show “Calibration” .
3. Press< ENTER>, the display will show “Calibration” .
4. The display show “Password=XXXX” .
5. Press <ENTER> to confirm or press <MODE/ESC> to return to the main menu.

## **8.6 Users mode set**

In this menu, user can select different channels list by different sequence:

For example, after the user enter this manual, if select Auto Program = CH 22, means in this User’s mode, the “Dimmer” is in Channel 16.

### **8.6.1 User mode**

With this function, you can create user defined channel orders.

### **8.6.2 Edit User Mode**

With this function, you can adjust the rest user defined channel order.

1. Tap <MODE/ESC>button, access the main menu, Tap the <Up/Down>button until “Users mode set”is displayed. Press ENTER, the display will show “Users mode set”.
2. The display show “Edit User Mode”frist channel, Press <Up/Down> the display will show “Edit User Mode” .
3. Press <ENTER> to confirm or press <MODE/ESC> to return to the main menu.

## **8.7 Edit pro**

### **8.7.1 Select programs**

With this function, you can select the program for the Program Run.

### 8.7.2 Edit program

With this function, you can edit the internal programs.

### 8.7.3 Edit scenes

With this function, you can edit the scenes of the internal programs.

### 8.7.4 Rec. Controller

The moving head features an integrated DMX-recorder by which you can transmit the programmed scenes from your DMX-controller to the moving head. Adjust the desired scene numbers via the encoder (from – to). When you call up the scenes at your controller, they will automatically be transmitted to the moving head.

#### Excursion:

A Master unit can send up to 3 different data groups to the Slave units, i.e. a Master unit can start 3 different Slave units, which run 3 different programs. The Master unit sends the 3 program parts in a continuous loop.

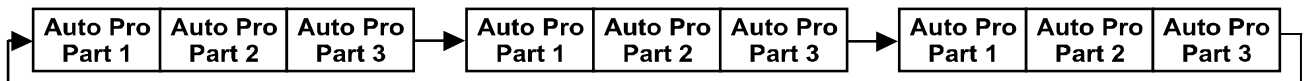

The Slave unit receives data from the Master unit according to the group which the Slave unit was assigned to. If e.g. a Slave unit is set to “Slave 1” in the menu “Set to Slave”, the Master unit sends “Auto Program Part 1” to the Slave unit. If set to “Slave 2”, the Slave unit receives “Auto Program Part 2”.

To start a Auto Program please proceed as follows:

#### 1. Slave-Setting

- Select “Function Mode” by turning the encoder.
- Press the Enter button to confirm.
- Select “Set to slave” by turning the encoder.
- Press the Enter button to confirm.
- Turn the encoder to select “Slave 1”, “Slave 2” or “Slave 3”.
- Press the Enter button to confirm.
- Press the MODE/ESC button in order to return to the main menu.

#### 2. Automatic Program Run

- Select “Function Mode” by turning the encoder.
- Press the Enter button to confirm.
- Select “Auto Program” by turning the encoder.
- Press the Enter button to confirm.
- Turn the encoder to select “Master” or “Alone”. The selection "Alone" means Stand Alone-mode and "Master" that the device is defined as master.
- Press the Enter button to confirm.
- Press the MODE/ESC button in order to return to the main menu.

#### 3. Program selection for Auto Pro Part

- Select “Edit program” by turning the encoder.



- Press the Enter button to confirm.
- Select “Select programs” by turning the encoder.
- Press the Enter button to confirm.
- Turn the encoder to select “Auto Pro Part 1”, “Auto Pro Part 2” or “Auto Pro Part 3”, and thus select which Slave program is to be sent. Selection “Part 1” means, that the Slave unit runs the same program as the master units.
- Press the Enter button to confirm.
- Press the MODE/ESC button in order to return to the main menu.

#### **4. Program selection for Edit Program**

- Select “Edit program” by turning the encoder.
- Press the Enter button to confirm.
- Select “Edit program” by turning the encoder.
- Press the Enter button to confirm.
- Turn the encoder to select the desired program. With this function you can edit specific scenes into a specific program.
- Press the Enter button to confirm.
- Press the MODE/ESC button in order to return to the main menu.

#### **5. Automatic Scene Recording**

- Select “Edit program” by turning the encoder.
- Press the Enter button to confirm.
- Select “Edit scenes” by turning the encoder.
- Turn the encoder to select the desired scene numbers. You can program a maximum number of 250
- Press the Enter button to confirm.
- Press the MODE/ESC button in order to return to the main menu.

Example:

Program 2 includes scenes: 10, 11, 12, 13

Program 4 includes scenes: 8, 9, 10

Program 6 includes scenes: 12, 13, 14, 15

Auto Pro Part 1 is Program 2;

Auto Pro Part 2 is Program 3;

Auto Pro Part 3 is Program 6

The 3 Slave groups run the Auto Program in certain time segments, as shown in the following picture:

Part 1:

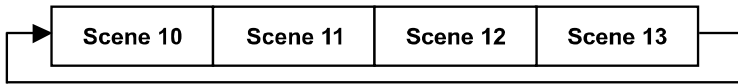

Part 2:

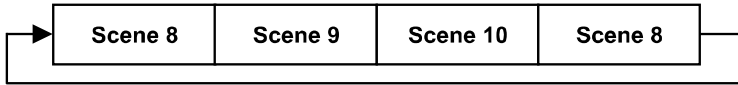

Part 3:

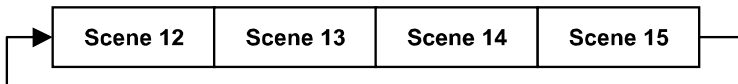

## 9. INSTRUCTIONS ON USE

DMX channel's functions and their values (21DMX channels):				
Mode/Channel		Value	Function	
St	Ba	Ex		
5	5	1		<b>PAN Movement 8bit :</b>
			0-255	Pan Movement
16		2		<b>Pan Fine 16bit</b>
			0-255	Fine control of Pan movement
6	6	3		<b>TILT Movement 8bit :</b>
			0-255	Tilt Movement
17		4		<b>Tilt Fine 16bit</b>
			0-255	Fine control of Tilt movement
7	7	5		<b>Speed Pan/Tilt movement:</b>
			0-225	max to min speed
			226-235	blackout by movement
		236-255	no function	
1	1			<b>Red LED -all arrays :</b>
			0-255	Red ( 0-Black , 255-100% Red )
2	2			<b>Green LED-all arrays :</b>
			0-255	Green ( 0-Black , 255-100% Green )
3	3			<b>Blue LED -all arrays :</b>
			0-255	Blue ( 0-Black , 255-100% Blue )
4	4			<b>White LED -all arrays :</b>
			0-255	White ( 0-Black , 255-100% White )
		13		<b>Red LED -array 1 :</b>

			0-255	Red ( 0-Black , 255-100% Red )
		14		<b>Green LED-array 1 :</b>
			0-255	Green ( 0-Black , 255-100% Green )
		15		<b>Blue LED -array 1 :</b>
			0-255	Blue ( 0-Black , 255-100% Blue )
		16		<b>White LED -array 1 :</b>
			0-255	White ( 0-Black , 255-100% White )
		17		<b>Red LED -array 2 :</b>
			0-255	Red ( 0-Black , 255-100% Red )
		18		<b>Green LED-array 2 :</b>
			0-255	Green ( 0-Black , 255-100% Green )
		19		<b>Blue LED -array 2 :</b>
			0-255	Blue ( 0-Black , 255-100% Blue )
		20		<b>White LED -array 2 :</b>
			0-255	White ( 0-Black , 255-100% White )
8	8	6		<b>Shutter, strobe:</b>
			0-15	Led trun off
			16-249	Strobe effect slow to fast
			250-255	Led turn on
9	9	7		<b>Dimmer intensity:</b>
			0-255	Intensity 0 to 100%
10	10	8		<b>Color Macro:</b>
			0-7	No function
			8--255	Color Rainbow from slow to fast
11	11	9		<b>Color Presets:</b>
			0-10	No function
			11--20	White2700k
			21--30	White3200k
			31-40	White4300k
			41-50	White5600k
			51-60	White6500k
			61-70	White8000k
			71--100	Blue/Red
			101--130	Blue/Green
			131--160	Green/Red
			161 --190	Red/Blue
			191--220	Green/Blue
221--255	Red/Green			
12	12	10		<b>Color Mode:</b>
			0-189	No function
			190-254	Edit a new white balance
			255	Store a new white balance
13	13	11		<b>Chase Patterns:</b>
			0-10	Led trun off

			11-40	Chase 1
			41-70	Chase 2
			71-100	Chase 3
			101-130	Chase 4
			131-160	Chase 5
			161-190	Chase 6
			191-220	Chase 7
			221-255	Chase 8
14	14	12		<b>Chase Speed:</b>
			0-255	Fast to Slow
15	15	21		<b>Reset, internal programs:</b>
			0-79	Normal
			80-84	All motor reset
			85-87	Scan motor reset
			88-90	no function
			91-93	Store white balance enabled
			94-96	no function
			97-99	Others motor reset
			100-119	Internal program 1 (secne1~8 of EEPROM)
			120-139	Internal program 2 (secne9~16 of EEPROM)
			140-159	Internal program 3 (secne17~24 of EEPROM)
			160-179	Internal program 4 (secne25~32 of EEPROM)
			180-199	Internal program 5 (secne33~40 of EEPROM)
			200-219	Internal program 6 (secne41~48 of EEPROM)
			220-239	Internal program 7 (secne49~56 of EEPROM)
			240-255	Music Control (secne of Program 1)

## 10. ERROR MESSAGE

When you turn on the fixture, it will make a reset at first. The display may show “Err channel is XX” while there are problems with one or more channels. “XX” stands for channel 1, 2, 3, 4, 5, 6 who has the testing sensor for positioning. For example, when the display shows “Err channel is Pan movement”, it means there is some error in channel 1. If there are some errors on channel 1, channel 2, channel 6 at the same time, you may see the error message, “Err channel is Pan movement” “Err channel is Tilt movement”, “Err channel is red led”, flash repeated for 2 times, and then the fixture will generate a second reset. If the fixture remain error message after performing reset more than 2 times, only the channels which have errors can not work properly, others can work as usual. Please contact with dealer or manufacturer for service, self repair is not allowed.

### PAN- movement Er

(PAN-yoke movement error) This message will appear after the reset of the fixture if the yoke’s magnetic-indexing circuit malfunction (sensor failed or magnet missing) or the stepping-motor is defective (or its driving IC on the main PCB). The PAN- movement is not located in the default position after the reset.

### **TILT- movement Er**

(TILT-head movement error) This message will appear after the reset of the fixture if the head's magnetic-indexing circuit malfunctions (sensor failed or magnet missing) or the stepping-motor is defective (or its driving IC on the main PCB). The TILT- movement is not located in the default position after the reset.

## **11. CLEANING AND MAINTENANCE**

The following points have to be considered during the inspection:

- 1) All screws for installing the devices or parts of the device have to be tightly connected and must not be corroded.
- 2) There must not be any deformations on the housing, color lenses, fixations and installation spots (ceiling, suspension, trussing).
- 3) Mechanically moved parts must not show any traces of wearing and must not rotate with unbalances.
- 4) The electric power supply cables must not show any damage, material fatigue or sediments. Further instructions depending on the installation spot and usage have to be adhered by a skilled installer and any safety problems have to be removed.



### **CAUTION!**

Disconnect from mains before starting maintenance operation.

In order to make the lights in good condition and extend the life time, we suggest a regular cleaning to the lights.

- 1) Clean the inside and outside lens each week to avoid the weakness of the lights due to accumulation of dust.
- 2) Clean the fan each week.
- 3) A detailed electric check by approved electrical engineer each three month, make sure that the circuit contacts are in good condition, prevent the poor contact of circuit from overheating.

We recommend a frequent cleaning of the device. Please use a moist, lint- free cloth. Never use alcohol or solvents.

Please refer to the instructions under “Installation instructions”.

Should you need any spare parts, please order genuine parts from your local dealer.

## **12. TECHNICAL SPECIFICATIONS**

**Power supply:** AC100-240V~, 50/60Hz

**Power consumption:** 130W

**Packing dimensions:** 42.5 x 32 x 24 cm

**Net weight:** 5 KGS

**Gross weight:** 7.5 KGS

***Remark:*** errors and omissions for every information given in this manual excepted. All information is subject to change without prior notice.