

MP130E N-765 NEXACT® Stage User Manual

Version: 1.0.0

Date: 29.07.2015

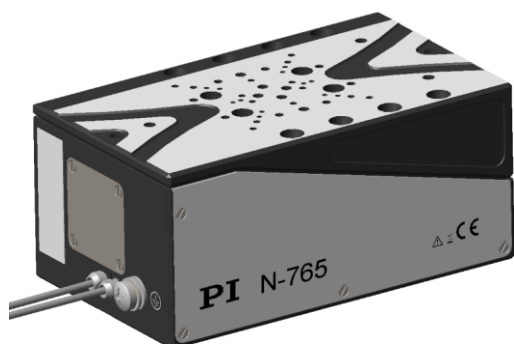

This document describes the following product:

- **N-765.060**
Precision Z Stage, 6.5 mm Travel Range,
PIOne Linear Encoder, 0.5 nm Resolution,
25 N Push/Pull Force, Dimensions
65 x 110 x 56 mm (W x L x H),
Piezoelectric Stepping Drive NEXACT®



Physik Instrumente (PI) GmbH & Co. KG is the owner of the following trademarks:
PI®, PIC®, PICMA®, PLine®, PIFOC®, PIMag®, PiezoWalk®, NEXACT®,
NEXLINE®, NanoCube®, NanoAutomation®

© 2015 Physik Instrumente (PI) GmbH & Co. KG, Karlsruhe, Germany. The text, photographs and drawings in this manual are protected by copyright. With regard thereto, Physik Instrumente (PI) GmbH & Co. KG retains all the rights. The use of any text, images and drawings is permitted only in part and only when indicating the source.

Original instructions

First printing: 29.07.2015

Document number: MP130E, LMo, Version 1.0.0

Subject to change without notice. This manual is superseded by any new release. The latest release is available for download (p. 3) on our website.



Contents

1	About this Document	1
1.1	Objective and Target Audience of this User Manual	1
1.2	Symbols and Typographic Conventions	1
1.3	Definition	2
1.4	Figures	3
1.5	Other Applicable Documents	3
1.6	Downloading Manuals	3
2	Safety	5
2.1	Intended Use	5
2.2	General Safety Instructions	5
2.3	Organizational Measures	6
3	Product Description	7
3.1	Product View	7
3.2	Product Labeling	8
3.3	Scope of Delivery	10
3.4	Suitable Controllers	10
3.5	Technical Features	11
3.5.1	Linear Encoder (Sensor)	11
3.5.2	Reference Point Switch	11
4	Unpacking	13
5	Installation	15
5.1	General Notes on Installation	15
5.2	Connecting the N-765 to the Protective Earth Conductor	17
5.3	Mounting the N-765 on a Surface	19
5.4	Setting Up a Multi-Axis System	22
5.4.1	General Information on Setting Up a Multi-Axis System	23
5.4.2	Setting Up a Z System	23
5.5	Affixing the Load to the N-765	25
5.6	Connecting the N-765 to the Controller	27

6	Start-Up and Operation	29
6.1	General Notes on Start-Up and Operation	29
6.2	Operating Parameters	31
6.3	Operating the N-765	31
6.4	Discharging the Piezo Actuators of the Drive	32
7	Maintenance	33
7.1	General Notes on Maintenance	33
7.2	Performing a Maintenance Run	34
7.3	Cleaning the N-765	34
8	Troubleshooting	35
8.1	General Notes on Troubleshooting	35
8.2	Possible Causes and Correction	36
9	Customer Service	37
10	Technical Data	39
10.1	Specifications	39
10.1.1	Data Table	39
10.1.2	Maximum Ratings	40
10.1.3	Ambient Conditions and Classifications	41
10.2	Dimensions	42
10.3	Pin Assignment	43
10.3.1	Drive Connection for N-765	43
10.3.2	Sensor Connection for N-765	44
10.3.3	Pin Assignment of the N664B0001 Adapter	45
11	Old Equipment Disposal	47
12	EC Declaration of Conformity	49

1 About this Document

In this Chapter

Objective and Target Audience of this User Manual	1
Symbols and Typographic Conventions	1
Definition	2
Figures	3
Other Applicable Documents	3
Downloading Manuals	3

1.1 Objective and Target Audience of this User Manual

This manual contains information on the intended use of the N-765.

It assumes that the reader has a fundamental understanding of basic servo systems as well as motion control concepts and applicable safety procedures.

The latest versions of the user manuals are available for download (p. 3) on our website.

1.2 Symbols and Typographic Conventions

The following symbols and typographic conventions are used in this user manual:

CAUTION



Dangerous situation

If not avoided, the dangerous situation will result in minor injury.



- Actions to take to avoid the situation.

NOTICE



Dangerous situation

If not avoided, the dangerous situation will result in damage to the equipment.

- Actions to take to avoid the situation.

INFORMATION

Information for easier handling, tricks, tips, etc.

Symbol/ Label	Meaning
1. 2.	Action consisting of several steps whose sequential order must be observed
➤	Action consisting of one or several steps whose sequential order is irrelevant
▪	List item
p. 5	Cross-reference to page 5
RS-232	Labeling of an operating element on the product (example: socket of the RS-232 interface)
	Warning sign on the product which refers to detailed information in this manual.

1.3 Definition

Term	Explanation
Load capacity	Maximum load capacity in the vertical direction when the stage is mounted horizontally. The contact point of the load is in the center of the platform.
Linear encoder	The linear encoder is an incremental sensor for capturing changes in position. Signals from the sensor are used for axis position feedback. After switching on the controller a reference point definition must be performed before absolute target positions can be commanded and reached.

1.4 Figures

For better understandability, the colors, proportions and degree of detail in illustrations can deviate from the actual circumstances. Photographic illustrations may also differ and must not be seen as guaranteed properties.

1.5 Other Applicable Documents

The devices and software tools which are mentioned in this documentation are described in their own manuals.

Product	Document
E-861 NEXACT® Servo Controller	PZ205E User Manual
PIMikroMove	SM148E Software Manual

1.6 Downloading Manuals

INFORMATION

If a manual is missing or problems occur with downloading:

- Contact our customer service department (p. 37).

INFORMATION

For products that are supplied with software (CD in the scope of delivery), access to the manuals is protected by a password. Protected manuals are only displayed on the website after entering the password.

The password is included on the CD of the product.

For products with CD: Identify the password

1. Insert the product CD into the PC drive.
2. Switch to the Manuals directory on the CD.
3. In the Manuals directory, open the Release News (file including **releasenews** in the file name).
4. Find the user name and the password in the section "User login for software download" in the Release News.

Downloading Manuals

1. Open the website **http://www.pi.ws**.
2. Click **Info**.
3. If you have a user name and password:
 - a) Click **Login**.
 - b) Log in with the user name and password.
4. Click **>> Product Downloads**.
5. In the **Product Files** area, click the corresponding product category.
6. On the right-hand side of the page, select the corresponding sub-category.
7. Navigate to the product code on the page.

The following manuals are displayed:

- Freely accessible manuals
 - Manuals that are protected by a password
8. Click the desired manual and save it to the hard disk of your PC or to a data storage medium.

2 Safety

In this Chapter

Intended Use	5
General Safety Instructions	5
Organizational Measures.....	6

2.1 Intended Use

The N-765 is a laboratory device as defined by DIN EN 61010-1. It is intended to be used in enclosed spaces and in an environment which is free of dirt, oil, and lubricants.

In accordance with its design and realization, the N-765 is intended for positioning, adjusting and shifting loads along the Z axis at various velocities.

The N-765 is only intended for horizontal mounting.

The N-765 is a stage for nanopositioning technology. The feed is produced by NEXACT® piezo actuators coupled to a ceramic rail (PiezoWalk® principle).

The N-765 is equipped with a linear encoder for direct position measurement.

The intended use of the N-765 is only possible when installed and in conjunction with a suitable controller (p. 10). The controller is not included in the scope of delivery of the N-765.

2.2 General Safety Instructions

The N-765 is built according to state-of-the-art technology and recognized safety standards. Improper use can result in personal injury and/or damage to the N-765.

- Only use the N-765 for its intended purpose, and only use it if it is in a good working order.
- Read the user manual.
- Immediately eliminate any faults and malfunctions that are likely to affect safety.

The operator is responsible for the correct installation and operation of the N-765.

2.3 Organizational Measures

User manual

- Always keep this user manual available with the N-765.
The latest versions of the user manuals are available for download (p. 3) on our website.
- Add all information given by the manufacturer to the user manual, for example supplements or Technical Notes.
- If you pass the N-765 on to other users, also include this user manual as well as other relevant information provided by the manufacturer.
- Only use the device on the basis of the complete user manual. Missing information due to an incomplete user manual can result in minor injury and property damage.
- Only install and operate the N-765 after you have read and understood this user manual.

Personnel qualification

The N-765 may only be installed, started up, operated, maintained and cleaned by authorized and appropriately qualified personnel.

3 Product Description

In this Chapter

Product View	7
Product Labeling.....	8
Scope of Delivery	10
Suitable Controllers	10
Technical Features	11

3.1 Product View

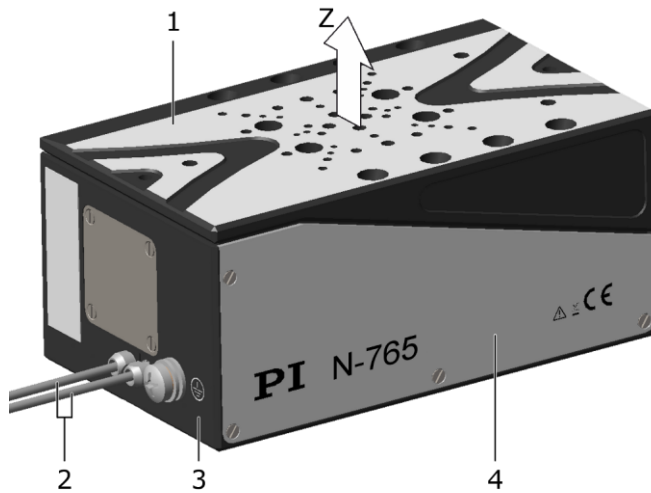

Figure 1: N-765 product view

- 1 Moving platform
- 2 Cables for connecting sensor and drive to the controller
- 3 Base body
- 4 Side cover

The arrow in the figure shows the positive direction of motion.

3.2 Product Labeling

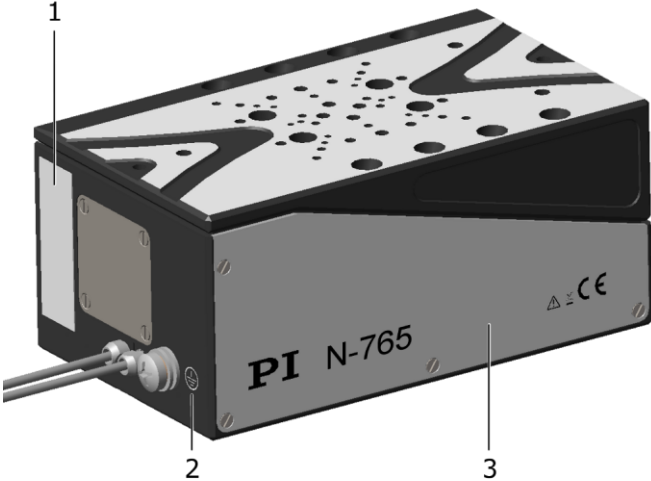





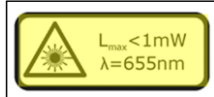

Figure 2: Position of the product labeling on the stage



Figure 3: Position of the product labeling on the sensor connector (f)

Position	Labeling	Description
1, 3	N-765 / N-765.060	Product name. Characters following the period identify the model exactly.
1	414000946	Serial number (example), individual for each N-765 Meaning of the places (counting from left): 1 = internal information, 2 and 3 = year of manufacture, 4 to 9 = consecutive numbers
1, 3		Warning sign "Observe manual!"
1, 3		Old equipment disposal
1	Country of origin: Germany	Country of origin
1, 3	PI	Manufacturer's logo
1	WWW.PIMICOS.COM	Manufacturer's address (website)
1, 3	CE	CE conformity mark
2		Symbol for the protective earth conductor, marks the protective earth connection of the N-765 (p. 17)
4		Notice of laser radiation (p. 33) (here: Top side of sensor connector)
4		Warning sign "Observe manual!" (here: Top side of sensor connector)
5		Warning sign and values for the laser (p. 33) (here: Bottom side of sensor connector)

3.3 Scope of Delivery

Item ID	Components
N-765	Precision Z Stage, 6.5 mm Travel Range, PIONEER Linear Encoder, 0.5 nm Resolution, 25 N Push/Pull Force, Dimensions 65 x 110 x 56 mm (W x L x H), Piezoelectric Stepping Drive NEXACT®
5870500002	Screw set for mounting of the N-765: <ul style="list-style-type: none"> ▪ 4 M3x16 socket-head cap screws, ISO 4762 ▪ 2 dowel pins 3 m6 x 8, ISO 2338
000036450	Accessories for connection to the grounding system: <ul style="list-style-type: none"> ▪ 1 M4x8 flat-head screw with cross recess, ISO 7045 ▪ 2 safety washers ▪ 2 flat washers
N664B0001	Adapter Sub-D 15 (m) to HD Sub-D 15 (f) for sensor connection
MP137EK	Short instructions for NEXACT® stage

3.4 Suitable Controllers

Controller	Description
E-861.1A1	Digital NEXACT® Controller

- To order, contact our customer service department (p. 37).

3.5 Technical Features

3.5.1 Linear Encoder (Sensor)

The stage is equipped with an optical linear encoder. For the encoder resolution, refer to the table in the "Specifications" section (p. 39).

Optical linear encoders measure the actual position directly (direct metrology). Therefore, errors occurring in the drivetrain, such as nonlinearity, backlash or elastic deformation, cannot influence the measurement of the position.

3.5.2 Reference Point Switch

The stage is equipped with a direction-sensing reference point switch that is located approx. 1 mm in front of the lower travel range limit. This sensor sends a TTL signal indicating whether the stage is on the positive or negative side of the reference point switch.

The commands that use the reference signal are described in the user manual of the controller and/or in the corresponding software manuals.

4 Unpacking

1. Unpack the N-765 with care.
2. Compare the contents against the items covered by the contract and against the packing list.
3. Inspect the contents for signs of damage. If parts are missing or you notice signs of damage, contact PI immediately.
4. Keep all packaging materials in case the product needs to be returned.

5 Installation

In this Chapter

General Notes on Installation	15
Connecting the N-765 to the Protective Earth Conductor	17
Mounting the N-765 on a Surface	19
Setting Up a Multi-Axis System	22
Affixing the Load to the N-765	25
Connecting the N-765 to the Controller	27

5.1 General Notes on Installation

NOTICE



Damage from changes in position due to external forces!

Displacement of the moving platform of the stage from externally acting forces can damage the drive. Changes in position of the moving platform that are triggered by externally acting forces can also damage the load or the environment.

- Make sure that forces acting on the moving platform in the direction of motion do **not** exceed the load capacity of the stage (p. 39).
- Initiate all motions by sending motion commands to the controller. Do **not** displace the moving platform manually.

NOTICE



Malfunction due to soiling!

Any type of soiling, e.g. dust, oil, lubricant or condensation, will render the N-765 inoperable.

- Keep the N-765 free from dirt and condensation.

NOTICE



Malfunction due to radiation!

Radiation (e.g. X-rays) will render the N-765 inoperable.

- Protect the N-765 from radiation.

NOTICE**Damage from incorrect mounting!**

Incorrect mounting of the N-765 or incorrectly mounted parts can damage the N-765.

- Only mount the N-765 and the loads on the mounting fixtures (holes) intended for this purpose.

NOTICE**Warping of the N-765 due to mounting on uneven surfaces!**

Mounting the N-765 on an uneven surface can warp the N-765. Warping reduces the accuracy.

- Mount the N-765 on an even surface. The recommended evenness of the surface is $\leq 3 \mu\text{m}$.
- For applications with large temperature changes:
Only mount the N-765 on surfaces that have the same or similar thermal expansion properties as the N-765.

NOTICE**Damage from unsuitable cables!**

Unsuitable cables can damage the stage and the electronics.

- Only use cables provided by PI for connecting the N-765 to the electronics.

INFORMATION

For optimum repeatability, all components must be firmly affixed to each other.

5.2 Connecting the N-765 to the Protective Earth Conductor

INFORMATION

- Observe the applicable standards for mounting the protective earth conductor.

On the N-765, there is an M4 hole next to the cable exit for connecting the protective earth conductor. In the following figure, this hole is marked with the symbol for the protective earth conductor \oplus .



Figure 4: N-765: Protective earth connection in the base body

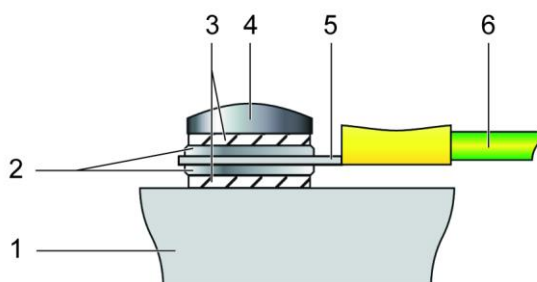

Figure 5: Mounting of the protective earth conductor (profile view)

- 1 Base body of the N-765
- 2 Flat washer
- 3 Safety washer
- 4 Screw
- 5 Cable lug
- 6 Protective earth conductor

Prerequisites

- ✓ You have read and understood the general notes on installation (p. 15).
- ✓ The N-765 is **not** connected to the controller.

Tools and accessories

- Suitable protective earth conductor: Cross-sectional area of the cable $\geq 0.75 \text{ mm}^2$
- Supplied M4 screw set for protective earth (p. 10) for mounting a protective earth conductor
- Suitable screwdriver

Connecting the N-765 to the protective earth conductor

1. If necessary, fasten a suitable cable lug to the protective earth conductor.
2. Fasten the cable lug of the protective earth conductor using the M4 screw on the protective earth connection of the N-765 as shown in the profile view.
3. Tighten the M4 screw with a torque of 1.2 Nm to 1.5 Nm.
4. Make sure that the contact resistance at all connection points relevant for mounting the protective earth conductor is $< 0.1 \Omega$ at 25 A.

5.3 Mounting the N-765 on a Surface

INFORMATION

The mounting holes in the base body of the stage are accessible from above only when the moving platform is at the lower travel range limit (delivery state). If necessary:

- Start up the stage (p. 29) and move the moving platform to the lower travel range limit (see user manual of the controller).

Options for mounting the N-765 onto a surface

The mounting holes of the N-765 are intended for the following mounting options:

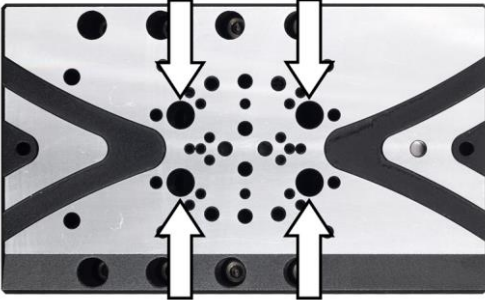
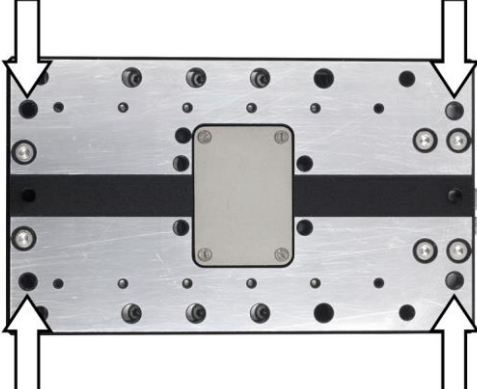
Mounting option	Mounting holes, details see "Dimensions" (p. 42)
Mounting from above with M3x16 screws	
Mounting from below with M4 screws	

NOTICE**Screws that are too long!**

The N-765 can be damaged by screws that are screwed in too deeply.

- Observe the depth of the mounting holes (p. 42).
- Only use screws of the correct length for the respective mounting holes.

NOTICE**Protruding screw heads!**

Protruding screw heads can damage the N-765.

- Ensure that the screw heads do not protrude from countersunk holes so that they do not interfere with the stage motion.

Prerequisites

- ✓ You have read and understood the general notes on installation (p. 15).
- ✓ You have provided a suitable surface. For the required position of the holes, see "Dimensions" (p. 42).
 - For mounting from **above with M3x16 screws**: Four M3 holes with a depth of at least 6.4 mm are provided.
 - For mounting from **below with M4 screws**: Four through-holes with \varnothing 4.5 mm for M4 screws are provided. The thickness of the surface and the depth of the counterbores at the through-holes in the surface are matched so that compliance with the maximum screw-in depth of 7 mm in the N-765 is observed.
 - The evenness of the surface is $\leq 3 \mu\text{m}$.
 - For applications with large temperature changes:
The surface should have the same or similar thermal expansion properties as the N-765.
- ✓ You have accounted for the space required to route cables without bending and according to regulations.

Tools and accessories

- Screws according to the selected mounting option (see above):
 - 4 M3x16 screws ISO 4762, included in the scope of delivery (p. 10)
 - or
 - 4 M4 screws of suitable length, not in the scope of delivery
- Suitable screwdriver

Mounting the N-765 on a Surface

1. Only for mounting from **above**:

When the required mounting holes in the base body of the N-765 are covered by the moving platform:

- Start up the stage (p. 29) and move the moving platform to the lower travel range limit (see user manual of the controller).
2. Align the stage on the surface so that the corresponding mounting holes in the stage and the surface overlap.
 3. Screw the screws into the mounting holes according to the selected mounting option (p. 29):
 - Mounting from **above**: Insert the screws through the moving platform and the base body of the N-765 into the surface.
 - Mounting from **below**: Insert the screws through the surface into the base body of the N-765. Maximum screw-in depth: 7 mm.

Maximum torque: 0.5 Nm

4. Make sure that screw heads do not protrude from the countersunk holes.
5. Check that the N-765 is affixed firmly to the surface.

5.4 Setting Up a Multi-Axis System

The N-765 can be used as a Z stage in multi-axis systems (XZ or XYZ combinations) (p. 23).

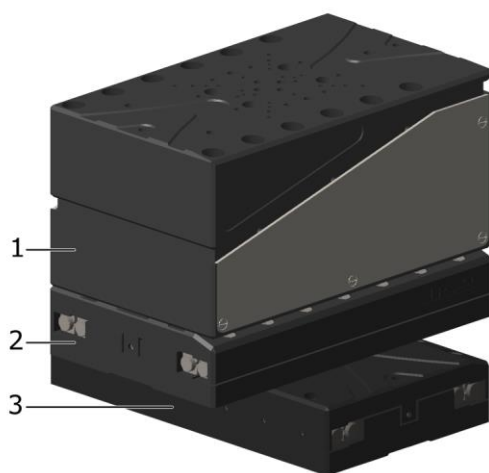

Figure 6: Example of a XYZ system: Two N-565.260 and one N-765

- 1 Upper stage (here: N-765)
- 2 Middle stage (here: N-565.260)
- 3 Lower stage (here: N-565.260)

5.4.1 General Information on Setting Up a Multi-Axis System

NOTICE



Impermissibly high load on the stages!

In a multi-axis system, the stage used for the Y and/or Z axis must also be moved. Impermissibly high loads interfere with the motion and can damage the stages.

- Include the masses of the moved stages in the calculation of the load to be moved.
- For all stages in a multi-axis system: Do **not** exceed the maximum permissible load.

- Only install and operate the multi-axis system after you have read and understood the user manuals of all components of the multi-axis system.

5.4.2 Setting Up a Z System

Prerequisites

- ✓ You have read and understood the general notes on installation (p. 15).
- ✓ You have read and understood the general notes on setting up a multi-axis system (p. 23).
- ✓ You have accounted for the space required to route cables without bending and according to regulations.

Tools and accessories

- 5870500002 screw set from the scope of delivery of the N-765 (p. 10):
 - 2 dowel pins 3 m6 x 8 ISO 2338 for use as locating pins
 - 4 socket head cap screws M3x16 ISO 4762
- Suitable screwdriver

Mount the N-765 on the N-565

Figure 7: Mount N-765 on N-565

1. Insert the two locating pins into the locating holes $\varnothing 3$ mm H7 in the moving platform of the N-565 (see figure above).
2. Place the N-765 on the N-565 so that the locating pins are inserted into the corresponding locating holes on the bottom side of the N-765.
3. Mount the N-765 on the N-565:
 - a) When the required mounting holes in the base body of the N-765 are covered by the moving platform: Start up the stage (p. 29) and move the moving platform to the lower travel range limit (see user manual of the controller).
 - b) Insert the four screws through the moving platform and the base body of the N-765 into the N-565.
 - c) Tighten the screws with a maximum torque of 0.5 Nm each.
 - d) Make sure that screw heads do not protrude from the countersunk holes.
4. Check that the N-765 is affixed firmly to the N-565.

5.5 Affixing the Load to the N-765

NOTICE

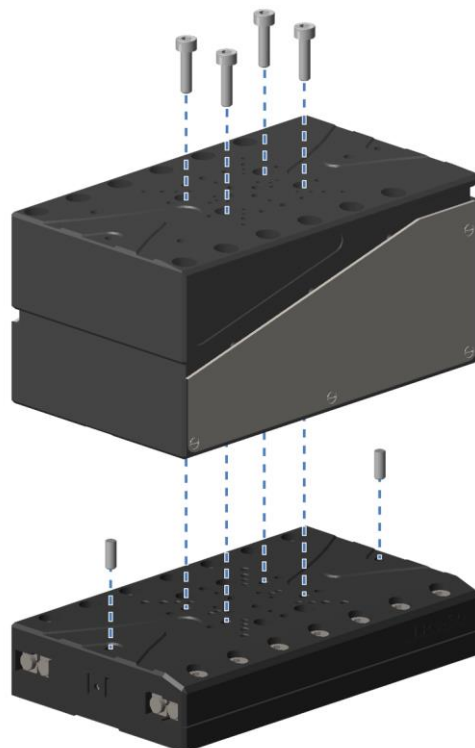

Screws that are too long!

The N-765 can be damaged by screws that are screwed in too deeply.

- Observe the depth of the mounting holes (p. 42).
- Only use screws of the correct length for the respective mounting holes.

Prerequisites

- ✓ You have read and understood the general notes on installation (p. 15).
- ✓ You have properly mounted the stage.
- ✓ You have prepared the load so that it can be affixed to the mounting holes on the moving platform:
 - The distance between the center of gravity of the load and the center of the moving platform is as small as possible in all directions.
 - At least three points are provided for affixing the load on the moving platform.

Tools and accessories

- At least three screws of suitable length. Options:
 - M2 screws
 - M2.5 screws
 - M3 screws
- Suitable tools for fastening the screws

Affixing the load to the N-765

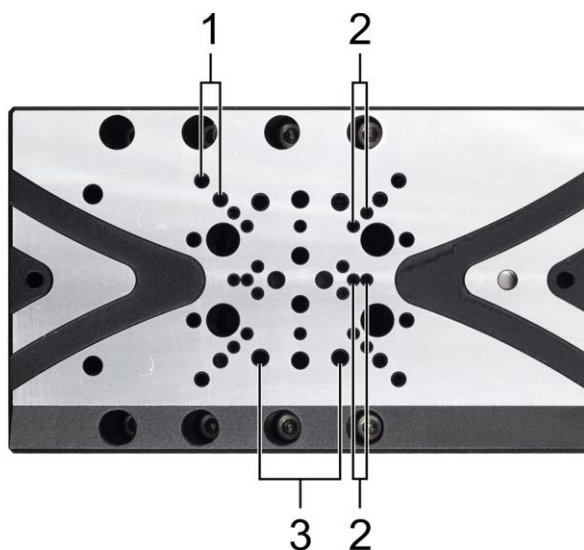

Figure 8: Mounting holes for affixing the load to the moving platform

- 1 8 x M2.5 holes with 5 mm thread depth
- 2 12 x M2 holes with 4 mm thread depth
- 3 4 x M3 holes with 6 mm thread depth

For the exact position, see "Dimensions (p. 42)"

1. Align the load so that the selected mounting holes in the moving platform can be used for affixing it.
2. Affix the load to the selected mounting holes in the moving platform using the screws.

Maximum screw-in depth in the moving platform of the N-765:

- M3 screws: 6 mm
- M2.5 screws: 5 mm
- M2 screws: 4 mm

Maximum torque:

- M3 screws: 1.2 Nm
- M2.5 screws: 0.7 Nm
- M2 screws: 0.35 Nm

3. Check that the load is affixed firmly to the moving platform of the stage.

5.6 Connecting the N-765 to the Controller

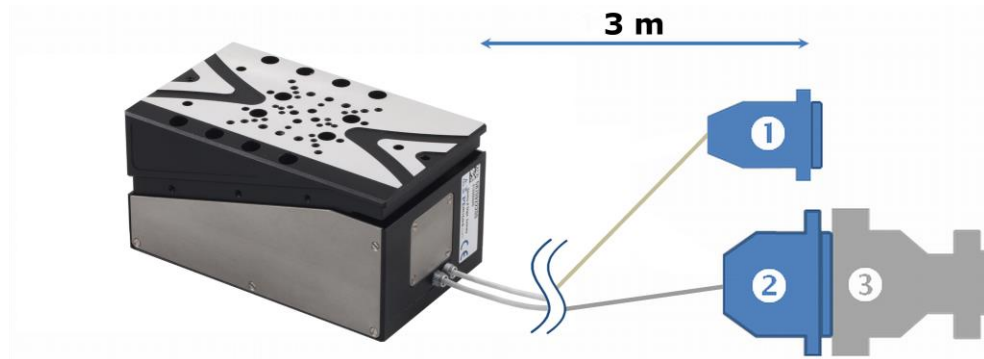

Figure 9: N-765: Connections

- 1 HD Sub-D 15 (m) drive connector
- 2 Sub-D 15 (f) sensor connector
- 3 Adapter Sub-D 15 (m) to HD Sub-D 15 (f)

Prerequisites

- ✓ You have read and understood the general notes on installation (p. 15).
- ✓ You have installed a suitable controller (p. 10).
- ✓ You have read and understood the user manual of the controller.
- ✓ The controller is switched off.

Tools and accessories

- N664B0001 adapter, in the scope of delivery (p. 10)
- Screwdriver for slotted screws (SL)

Connecting the N-765 to the E-861.1A1 controller

1. Connect the drive connector of the stage to the corresponding controller socket (see user manual of the controller).
2. Connect the sensor connector (f) of the stage to the controller:
 - a) Connect the sensor connector (f) of the stage to the connector side of the adapter (Sub-D 15 (m)).
 - b) Secure the connection with the integrated screws against accidental disconnection.
 - c) Connect the female side of the adapter (HD Sub-D 15 (f)) to the panel plug of the controller (see user manual of the controller).
3. Secure the connections on the controller with the integrated screws against accidental disconnection.

6 Start-Up and Operation

In this Chapter

General Notes on Start-Up and Operation	29
Operating Parameters	31
Operating the N-765	31
Discharging the Piezo Actuators of the Drive.....	32

6.1 General Notes on Start-Up and Operation

CAUTION



Risk of crushing by moving parts!

There is a risk of minor injuries caused by crushing which can occur between the moving parts of the stage and a stationary part or obstacle.

- Keep your fingers away from areas where they can get caught by moving parts.

NOTICE



Damage from collisions!

Collisions can damage the stage, the load to be moved and the environment.

- Make sure that no collisions are possible between the stage, the load to be moved and the environment in the motion range of the stage.
- Do not place any objects in areas where they can get caught by moving parts.
- Stop the motion immediately if a controller malfunction occurs.
- If possible, adapt the travel range limits of your mechanical system in the software that you use for commanding the motion.

NOTICE**Damage from changes in position due to external forces!**

Displacement of the moving platform of the stage from externally acting forces can damage the drive. Changes in position of the moving platform that are triggered by externally acting forces can also damage the load or the environment.

- Make sure that forces acting on the moving platform in the direction of motion do **not** exceed the load capacity of the stage (p. 39).
- Initiate all motions by sending motion commands to the controller. Do **not** displace the moving platform manually.

NOTICE**Uncontrolled oscillation!**

Your application and the N-765 can be damaged by uncontrolled oscillations. Uncontrolled oscillations can be identified by the fact that the stage approaches the target position too slowly or too fast or does not keep it stable (servo jitter).

If uncontrolled oscillations occur during the operation of the N-765:

- Immediately switch off the servo-control system of the affected axis.
- Check the settings of the servo-control parameters.

NOTICE**Destruction of the piezo actuators by electric flashovers!**

Using the N-765 in environments that increase the electrical conductivity can lead to the destruction of the piezo actuators of the NEXACT® drive by electric flashovers. Electric flashovers can be caused by moisture, high humidity, liquids and conductive materials (e.g. metal dust). In addition, electric flashovers can also occur in certain air pressure ranges due to the increased conductivity of the air.

- Avoid operating the N-765 in environments that can increase the electrical conductivity.
- Only operate the N-765 within the permissible ambient conditions and classifications (p. 41).

INFORMATION

Shock-like impacts can cause encoder malfunction.

- Protect the stage from shock-like impacts.
- Carry out a reference move (see user manual of the controller).

INFORMATION

The positive direction of motion is upward.

INFORMATION

The repeatability of the positioning is only ensured when the reference point switch is always approached from the same side. Recommended controllers from PI fulfill this requirement with their automatic direction detection for reference moves to the reference point switch.

6.2 Operating Parameters

If you use the software included in the scope of delivery of the E-861.1A1 controller, the operating parameters can be loaded from the *PIMicosStages2.dat* stage database.

- Download the PI Update Finder from the PI website (<http://update.pi-portal.ws>) and use it to update the *PIMicosStages2.dat* stage database on your PC.

For further information on the stage databases, refer to the user manual of the E-861.1A1 controller.

6.3 Operating the N-765

Prerequisites

- ✓ You have read and understood the general notes on start-up and operation (p. 29).
- ✓ You have read and understood the user manual of the controller.
- ✓ You have read and understood the user manual of the PC software.
- ✓ You have properly mounted the stage (p. 15).
- ✓ The controller and the required PC software have been installed. All connections with the controller have been established (see user manual of the controller).

Operating the N-765

- Follow the instructions in the manual of the controller used for startup and operation of the N-765.

6.4 Discharging the Piezo Actuators of the Drive

INFORMATION

The N-765 is driven by NEXACT[®] piezo actuators. Temperature changes and compressive stresses can induce charges in piezo actuators. After being disconnected from the electronics, piezo actuators can stay charged for several hours. Touching or short-circuiting the contacts in the drive connector of the N-765 can trigger unpleasant electric shocks.

If you want to avoid these unpleasant electric shocks:

- Discharge the stage **before** you pull out the drive connector from the controller.

Discharging the piezo actuators of the drive

If you want to pull out the connector of the drive from the controller:

1. If you are working in closed-loop operation: Switch off the servo mode on the controller.
2. Set the piezo voltage on the controller to 0 V by sending an `RNP` command (see user manual of the controller).
3. If possible: Switch off the controller.
4. Wait at least 10 seconds before disconnecting the controller.

7 Maintenance

In this Chapter

General Notes on Maintenance.....	33
Performing a Maintenance Run.....	34
Cleaning the N-765.....	34

7.1 General Notes on Maintenance

CAUTION



Risk of glare and irritation!

The linear encoder of the N-765 uses a class 2 laser according to DIN EN60825-1:2007. Technical data of the laser: $L_{\max} \leq 1 \text{ mW}$, $\lambda=655 \text{ nm}$.

On delivery and if used according to the intended use of the N-765, the laser is fully shielded. Laser radiation can exit from the laser only if N-765 is opened. The laser beam can cause glare and irritation.

- Do **not** open or disassemble the N-765.
- Contact our customer service department if there is any malfunction of the N-765.

NOTICE



Damage due to improper maintenance!

The stage can become misaligned as a result of improper maintenance. The specifications can change as a result (p. 39).

- Only loosen screws according to the instructions in this manual.

7.2 Performing a Maintenance Run

Depending on the operating conditions and the period of use of the N-765, the following maintenance measures are required:

Maintenance run

The maintenance run is performed to distribute the existing lubricant on the guidings of the N-765.

- To evenly distribute the existing lubricant on the stage guidings, perform a run across the entire travel range after 500 hours of operation or after 1 year at the latest.
- If you move the N-765 continuously over a small working range (<20 % of the entire travel range) in industrial operation, perform a run across the entire travel range every 5000 motion cycles.

Lubrication

Under laboratory conditions, the guidings on the N-765 only need to be lubricated in exceptional cases. For continuous industrial use, the lubrication intervals must be defined individually.

- Do not lubricate the guidings of the N-765 without consulting our customer service department (p. 37).
- To lubricate the guidings, follow the instructions given in the maintenance manual which you can obtain from our customer service department.
- Ensure that the drive and ceramic rail of the N-765 do not come into contact with lubricants.

7.3 Cleaning the N-765

Prerequisites

- ✓ You have discharged the piezo actuators of the N-765.
- ✓ You have disconnected the N-765 from the controller.

Cleaning the N-765

- Do **not** do any ultrasonic cleaning.
- When necessary, wipe the surfaces of the N-765 clean with a cloth that is slightly dampened with isopropanol or a mixture of isopropanol and DI water.

8 Troubleshooting

In this Chapter

General Notes on Troubleshooting	35
Possible Causes and Correction	36

8.1 General Notes on Troubleshooting

CAUTION



Risk of glare and irritation!

The linear encoder of the N-765 uses a class 2 laser according to DIN EN60825-1:2007. Technical data of the laser: $L_{\max} \leq 1 \text{ mW}$, $\lambda=655 \text{ nm}$.

On delivery and if used according to the intended use of the N-765, the laser is fully shielded. Laser radiation can exit from the laser only if N-765 is opened. The laser beam can cause glare and irritation.

- Do **not** open or disassemble the N-765.
- Contact our customer service department if there is any malfunction of the N-765.

8.2 Possible Causes and Correction

Problem	Possible Causes	Solution
Target position is approached too slowly or with overshoot	<ul style="list-style-type: none"> ▪ Servo-control parameters are not optimally set ▪ Large changes in the load 	<ol style="list-style-type: none"> 1. Switch off the servo-control system immediately. 2. Check the settings of the servo-control parameters. 3. If necessary, correct the settings of the servo-control parameters.
Target position is not kept stable		
Uncontrolled oscillation of the N-765		
Reduced holding force and feed force	<ul style="list-style-type: none"> ▪ Ceramic rail of the NEXACT® drive is soiled 	<ul style="list-style-type: none"> ➤ Contact our customer service department (p. 37).
No or limited motion	<ul style="list-style-type: none"> ▪ Excessive load 	<ul style="list-style-type: none"> ➤ Reduce the load (see "Data Table" (p. 39)).
	<ul style="list-style-type: none"> ▪ Ruler of the encoder is soiled, e.g. from being touched 	<ul style="list-style-type: none"> ➤ Contact our customer service department (p. 37).
	<ul style="list-style-type: none"> ▪ Encoder malfunction due to shock impact 	<ul style="list-style-type: none"> ➤ Carry out a reference move (see user manual of the controller)

If the problem that occurred with your system is not listed in the table above or cannot be solved as described, contact our customer service department (p. 37).

9 Customer Service

For inquiries and orders, contact your PI sales engineer or send us an e-mail (info@pi.ws).

- If you have questions concerning your system, have the following information ready:
 - Product codes and serial numbers of all products in the system
 - Firmware version of the controller (if present)
 - Version of the driver or the software (if present)
 - Operating system on the PC (if present)
- If possible: Take photographs or make videos of your system that can be sent to our customer service department if requested.

The latest versions of the user manuals are available for download (p. 3) on our website.

10 Technical Data

In this Chapter

Specifications	39
Dimensions	42
Pin Assignment.....	43

10.1 Specifications



10.1.1 Data Table

Preliminary data	N-765.060	Units	Tolerance
Active axes	Z		
Motion and Positioning			
Travel	6.5	mm	
Integrated sensor	Optical linear encoder PIONe		
Sensor resolution	0.5	nm	
Min. incremental motion	1	nm	typ.
Velocity, closed-loop	2.5	mm/s	max.
Unidirectional repeatability	±20	nm	typ.
Crosstalk, angular error at full travel range	±75	μrad	typ.
Mechanical Properties			
Load capacity	20	N	max.
Feed force (active)	25	N	max.
Holding force (passive)	25	N	max.
Drive Properties			
Motor Type	NEXACT® piezo stepping drive		
Operating voltage	-10 to 45	V	

Miscellaneous			
Operating temperature range	10 to 50 °C		
Mass	0.8	kg	±5 %
Material	Al (black anodized)		
Dimensions	65 × 80 × 20	mm	
Cable length	3	m	±10 mm
Connector	HD Sub-D (m) 15-pin (motor) HD Sub-D (f) 15-pin (sensor)		
Recommended controller/driver	E-861.1A1: single-axis motion controller E-712: modular controller system for up to 6 axes		

10.1.2 Maximum Ratings

The stage is designed for the following operating data:

Maximum Operating Voltage	Maximum Operating Frequency	Maximum Power Consumption
		
45 V	1500 Hz	20 W

10.1.3 Ambient Conditions and Classifications

The following ambient conditions and classifications must be observed for the N-765:

Area of application	For indoor use only
Maximum altitude	2000 m
Air pressure	1100 hPa to 0.1 hPa
Relative humidity	Highest relative humidity 80 % for temperatures to 31 °C, non-condensing Decreasing linearly to 50 % relative humidity at 40 °C, non-condensing
Operating temperature	10 °C to 50 °C
Storage temperature	-20 °C to 60 °C
Transport temperature	-20 °C to 60 °C
Overvoltage category (in acc. with EN 60664-1:2007 / VDE 0110-1)	II
Protection class (acc. to EN 61140 / VDE 0140-1)	I
Degree of pollution (acc. to EN 60664-1:2007 / VDE 0110-1)	1
Degree of protection (acc. to IEC 60529)	IP20

10.2 Dimensions

Dimensions in mm.

Signs that are used to separate decimal places:

- Depth and diameter of holes: Period
- All other dimensions: Comma

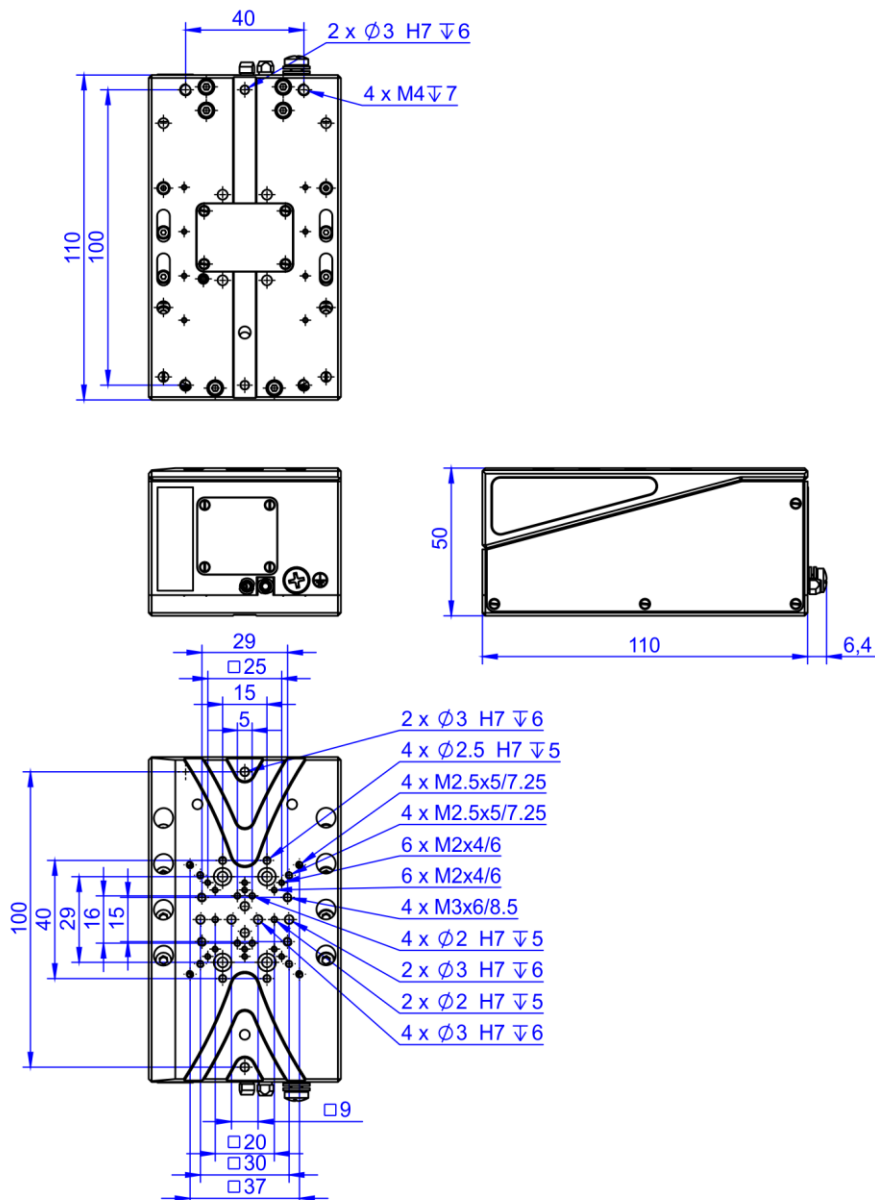

Figure 10: Dimensions of the N-765

10.3 Pin Assignment

10.3.1 Drive Connection for N-765

The HD Sub-D 15 (m) connector transmits the signals to control the drive.

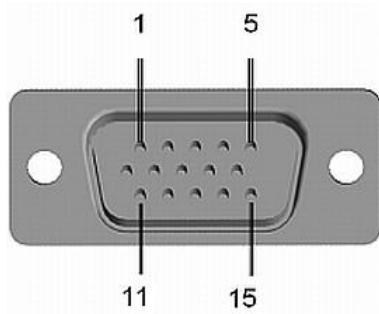

Figure 11: HD Sub-D 15 connector (m) for the drive, mating side

Pin	Function ¹	Direction
1	Piezo 1	Input
2	Piezo 3	Input
3	-	-
4	-	-
5	-	-
6	Piezo 0	Input
7	Piezo 2	Input
8	AMP (amplifier enable) ²	Output
9	-	-
10	-	-
11	Piezo GND	AGND
12	Piezo GND	AGND
13	-	-
14	-	-
15	GND	Digital GND

¹) The "-" sign indicates that the corresponding pin has not been assigned.

²⁾ This pin is connected to the GND in the connector shell. In the E-861.1A1 controller, this pin is used to activate the amplifiers.

10.3.2 Sensor Connection for N-765

The Sub-D 15 (f) connector transmits the signals to and from the integrated linear encoder and the reference point switch.

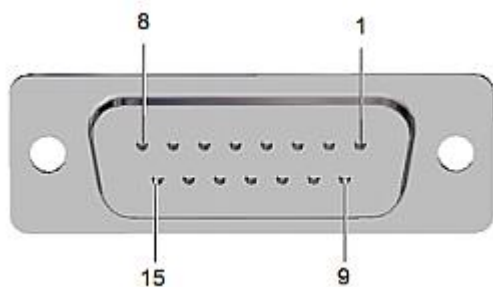

Figure 12: Sub-D 15 connector (f) for sensor, mating side

Pin	Signal*	Function	Direction
1	V _{DD}	Supply voltage (+ 5V)	Input
2	GND	GND	
3	COS +	Encoder signal 1 (cosine)	Output
4	COS -	Encoder signal 1 (cosine, inverted)	Output
5	-		
6	SIN +	Encoder signal 2 (sine)	Output
7	SIN -	Encoder signal 2 (sine, inverted)	Output
8	-		
9	-		
10	REF +	Reference point switch	Output
11	-		
12	-		
13	-		
14	-		
15	-		

* The "-" sign indicates that the corresponding pin has not been assigned.

10.3.3 Pin Assignment of the N664B0001 Adapter

The pin assignments for the N664B0001 adapter that is included in the scope of delivery of the N-765 are as follows:

- Sub-D 15 (m) connector: See "Sensor Connection for N-765" (p. 44)
- HD Sub-D 15 (f) connector: See following table

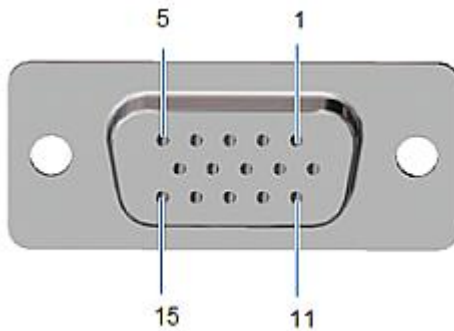

Figure 13: HD Sub-D 15 (f) connector for sensor, mating side

Pin	Signal*	Function	Direction
1	REF	Reference point switch	Output
2	V _{DD}	Supply voltage (+ 5V)	Input
3	-	-	-
4	COS +	Encoder signal 2 (cosine)	Output
5	SIN +	Encoder signal 1 (sine)	Output
6	-	-	-
7	-	-	-
8	-	-	-
9	COS -	Encoder signal 2 (cosine, inverted)	Output
10	SIN -	Encoder signal 1 (sine, inverted)	Output
11	-	-	-
12	-	-	-
13	-	-	-
14	GND	GND	GND
15	-	-	-

* The "-" sign indicates that the corresponding pin has not been assigned.

11 Old Equipment Disposal

In accordance with EU law, electrical and electronic equipment may not be disposed of in EU member states via the municipal residual waste.

Dispose of your old equipment according to international, national, and local rules and regulations.

In order to fulfil the responsibility as the product manufacturer, PI miCos GmbH undertakes environmentally correct disposal of all old PI miCos equipment made available on the market after 13 August 2005 without charge.

Any old PI miCos equipment can be sent free of charge to the following address:

PI miCos GmbH
Freiburger Strasse 30
79427 Eschbach, Germany



12 EC Declaration of Conformity

For the N-765, an EC Declaration of Conformity has been issued in accordance with the following European directives:

2004/108/EC, EMC Directive

2011/65/EU, RoHS Directive

The applied standards certifying the conformity are listed below.

Electromagnetic Emission: EN 61000-6-3:2007, EN 55011:2009

Electromagnetic Immunity: EN 61000-6-1:2007

