

Multi-piece Rims for Industrial and Construction Vehicles

RIM INSTRUCTION MANUAL



Warning

In order to handle rims safely, correctly, and reliably, work supervisors and workers involved in handling rims must comply with the following:

- Only begin work after carefully reading and understanding this Rim Instruction Manual. Failure to follow these instructions and safety precautions can be extremely hazardous and result in **SERIOUS INJURY** or **DEATH** to the tire changer or bystanders.
- Keep this manual in a designated place where it is easily accessible. Maintain this manual for future use and review it whenever necessary.
- If there are any questions or clarifications required concerning the contents of this manual, please contact your distributor.
- When transferring rims to someone else, be sure to give them this manual.



TOPY INDUSTRIES, LIMITED

Introduction

- **This Rim Instruction Manual concerns TOPY multi-piece rims for industrial and construction vehicles. It contains detailed information regarding their construction, specifications and handling to ensure the safe use of these products. Failure to follow these instructions and safety precautions can be extremely hazardous and result in **SERIOUS INJURY** or **DEATH** to the tyre changer or bystanders.**
- **Servicing of tyres and rims is very dangerous. This manual sets out important safety points and gives step-by-step explanations of the tasks involved in handling TOPY multi-piece rims.**
- **Read Safety Points in this manual and be sure that you fully understand them before starting tyre and rim servicing.**
- **When servicing tyres and rims, please refer to the following documents in addition to this manual:**
 - ◇ OSHA (U.S. Occupational Safety and Health Administration), Code of Federal Regulations 29 CFR Part 1910.177, “Servicing multi-piece and single-piece rim wheels”.
 - ◇ MSHA (Mine Safety and Health Administration) Introduction guide series IG60
 - ◇ SAE (Society of Automotive Engineers) J1337 Off-Road Rim Maintenance Procedures and Service Precautions.
 - ◇ RMA (U.S. Rubber Manufacturers Association) “CARE AND SERVICE OF OFF-THE-HIGHWAY TYRES”
 - ◇ RMA (U.S. Rubber Manufacturers Association) “TYRE INFORMATION SERVICE BULLETIN”
 - ◇ “Tyre and Rim Handling Manual”, published by tyre manufacturer.
 - ◇ “Work Manual”, published by vehicle manufacturer.
- **In this manual, the word “rim” is used as a general term which includes wheels with discs.**
- **Copying this manual for purposes other than ownership transfer is strictly forbidden.**



Contents

1. Safety precautions	3
2. General safety rules for rim handling	3
3. Important warnings	4
3.1 Precautions for prevention of "explosive separation of rim components"	4
3.2 Precautions for reduction or prevention of injury, death or damage from explosive separation	5
3.3 General precautions.....	6
4. Definitions of rim components	7
4.1 Names and size specifications of rim components.....	7
4.2 Designations of each rim component	8
5. Markings	9
5.1 Location of markings.....	9
5.2 Composition of markings	10
5.3 Rim component specifications.....	11
6. Matching charts	14
7. Examples of potentially hazardous matches	18
8. Procedures for servicing tyres and TOPY rims	24
8.1 How to demount tyre from TOPY 3-piece rim.....	25
8.2 How to mount tyre onto TOPY 3-piece rim	30
8.3 How to demount tyre from TOPY 5-piece rim.....	36
8.4 How to mount tyre onto TOPY 5-piece rim	43
8.5 Check point of servicing tyres and rims when rim remains installed on vehicle	52
9. Maintenance	54
9.1 Regular inspection check points.....	55
9.2 Inspections when servicing tyres and rims.....	56
9.3 Action as a result of inspection.....	61

1. Safety precautions

1. Definition for safety precautions

In this manual, safety precautions utilize signal words that are classified according to the level of risk and displayed as shown below. To ensure safety, understand the meanings of these signal words and follow all precautions.

 Warning	<p>Indicates a potential danger. If procedures and instructions are not followed, a serious accident causing death or severe injury could occur.</p>
 Caution	<p>If procedures and instructions are not followed, minor or moderate injury could occur.</p>
Notice	<p>If the precaution indicated here is not followed, property damage or malfunction/shortened lifespan of the product, etc. could occur.</p>

2. General safety rules for rim handling

2. General safety rules for rim handling

 Warning	
<ul style="list-style-type: none"> ● Safety shall be given the highest priority in all aspects of work <Safety First>. ● Before any work involving rim handling is carried out, use this manual to confirm the correct method of work as well as the precautions. Be aware of “what must be done” and “what must <u>not</u> be done” during the work. ● If there are any doubts about procedure or work safety while performing mounting, demounting, supplementing, removing, or fitting, suspend the work in progress immediately and seek the expert advice of a competent rim personnel. 	

3. Important warnings

3. Important warnings

Improper servicing of tyres and rims entails a serious risk of an “explosive separation of the rim”, which can lead to serious, even fatal, accidents for the worker as well as to others in the vicinity. Workers and persons responsible for supervising the work must comply strictly with the following warnings.

3.1 Precautions for prevention of "explosive separation of rim components"



Warning

- When servicing tyres and rims, always start by completely deflating the tyre. Completely deflate the tyre, before removing it from the rim.
- Before removing tyre and rim from a vehicle, completely deflate the tyre before removing the clamp components and other parts installed in the rim base.
- Before servicing a tyre, remove the valve core to ensure that all of the air can escape.
- Identify the appropriate combination of rim components using the matching charts and product markings.
- If air pressure has fallen 80% below the pressure at the time of inflation, or the tyre has been punctured, dismantle the rim and determine the cause. After you determine the cause, replace any deformed or damaged rim components that may have caused air leaks.
- Until the above-mentioned checks have been performed, **DO NOT** inflate.
- **DO NOT** combine rim components from different manufacturers.
There may be differences in terms of shape and other features between components from other companies and components manufactured by TOPY Industries (lock rings, rim bases, bead seat bands, side rings). Always make sure that components are not mixed by checking the manufacturer's markings prior to assembly.
- **DO NOT** use lock rings with open ends (ends that do not touch). There is a danger that the lock ring will not set correctly.
- **DO NOT** remove or install components or otherwise modify a rim in such a way that the product specifications are changed.
DO NOT make modifications involving welding, heating, soldering, etc. Such modifications could lead to the deformation as well as the deterioration of the strength and structural integrity of the rim components.
- When the tyre is being mounted, it is strictly forbidden to perform tasks that may generate heat, flames, or sparks such as welding, soldering or grinding. There is possibility to lead a explosion or a fire by excessive tyre pressure.
- Prior to inflation, it may be necessary to tap the rim components into position to set them. If it is, **DO NOT** use a steel mallet. Instead use a soft metal or hard plastic mallet. Use of a steel mallet could cause deformation or cracking of components.
- While inflating the tyre, when the air pressure reaches 35kPa (5psi), check whether the rim components are set correctly. If they are not set correctly, immediately stop the work in progress, deflate completely and disassemble the components. Inspect the component's mating surfaces and discard any components or materials that interfere with complete assembly. When the problem is resolved, resume assembly.
- **DO NOT** exceed the tyre pressure recommended by the tyre manufacturer.
- Tyre and rim assemblies should be stored so as to prevent unintended movement.
- Store inflated tyres in a manner in which they will not fall and cause accidents. Falling tyres can cause major accidents involving workers, and the impact from a significant fall could lead to the "explosive separation of rim components".
- Comply with the air pressure recommended by your tyre manufacturer. Do not exceed the standard air pressure without checking first with your TOPY rim dealer.

3. Important warnings

3.2 Precautions for reduction or prevention of injury, death or damage from explosive separation



Warning

- When inflating tyres, or when deflating tyres for tyre and rim servicing, workers must always be outside the range of the “hazardous trajectory” shown in the diagram below. Exercise extreme caution as the trajectory may widen.
- During inflation and deflation work, **DO NOT** allow other workers or third parties to approach the area surrounding the hazardous trajectory.

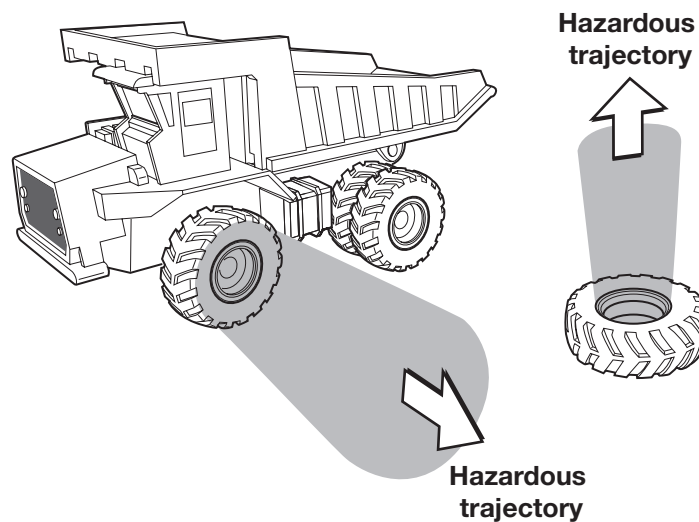

- Wherever possible, when inflating the tyre following rim assembly, ensure that the work is carried out with the tyre inside a “tyre inflation safety cage”.

Tyre inflation safety cage

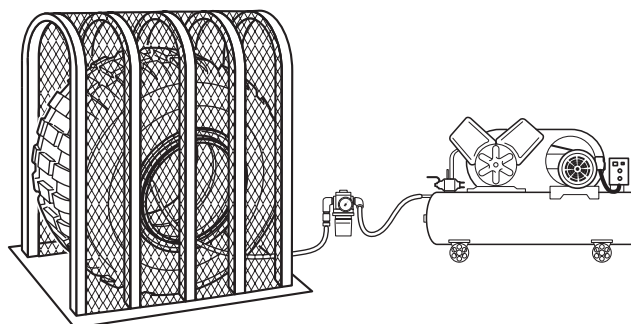

- Ensure that protective equipment is worn when servicing tyres and rims.
(Wear gloves, safety shoes, safety glasses, ear protection, hard hat)

3. Important warnings

3.3 General precautions



Warning

- Handling of tyres and rims should be carried out only by workers who have received training and accreditation based on instruction from a qualified work supervisor.
- Check the “Tyre and Rim Handling Manual” published by the tyre manufacturer for information on work and inspections, etc. involving tyre handling.
- When lifting heavy components or equipment, make sure that you use suitable lifting equipment and that you follow the instructions in the manual for the equipment to be used.
- When moving tyres and rims, be careful to avoid accidental drops or falls that could injure others in the vicinity.
- There are several types of tools for work involving tyre and rim handling. Be sure you have a proper understanding of how the tools are used and carry out the work in accordance with the proper procedures.
- Be sure to perform a visual examination of tyres and rims when conducting regular inspections of vehicles and tyres, or tyre rotations.
- Rim components that are deformed, bent, cracked, worn, corroded, or damaged should be clearly labeled to indicate their condition, and discarded.
- Use tyres and rims suited to the vehicle, as specified by the vehicle manufacturer and tyre manufacturer.
- In the case of dual assemblies, **DO NOT** operate the vehicle on a single tyre as the load capacity of the tyre and rim will be drastically reduced and may result in damage.

4. Definitions of rim components

4. Definitions of rim components

4.1 Names and size specifications of rim components

Rims are classified according to the number of components. There are 3-piece and 5-piece rims.

Names and specifications of 3-piece rim components

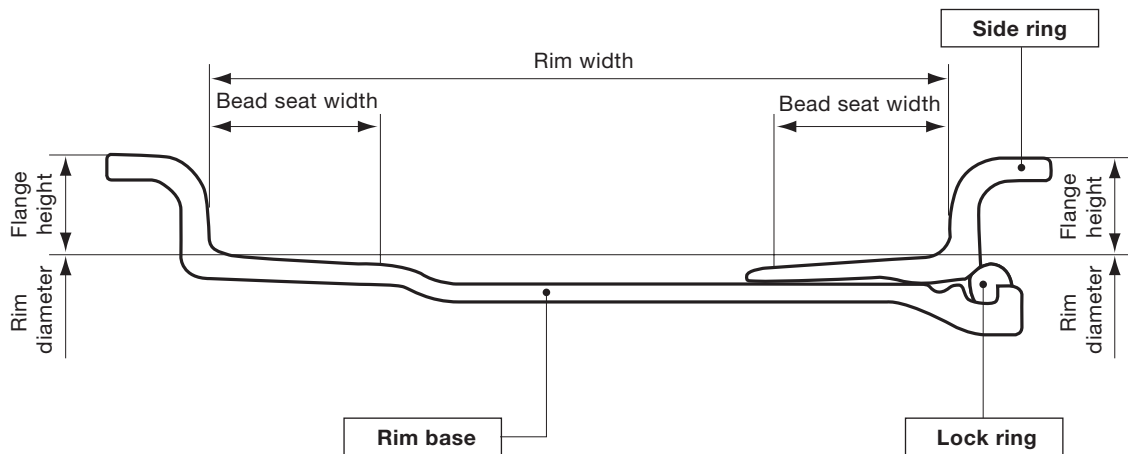

Names and specifications of 5-piece rim components

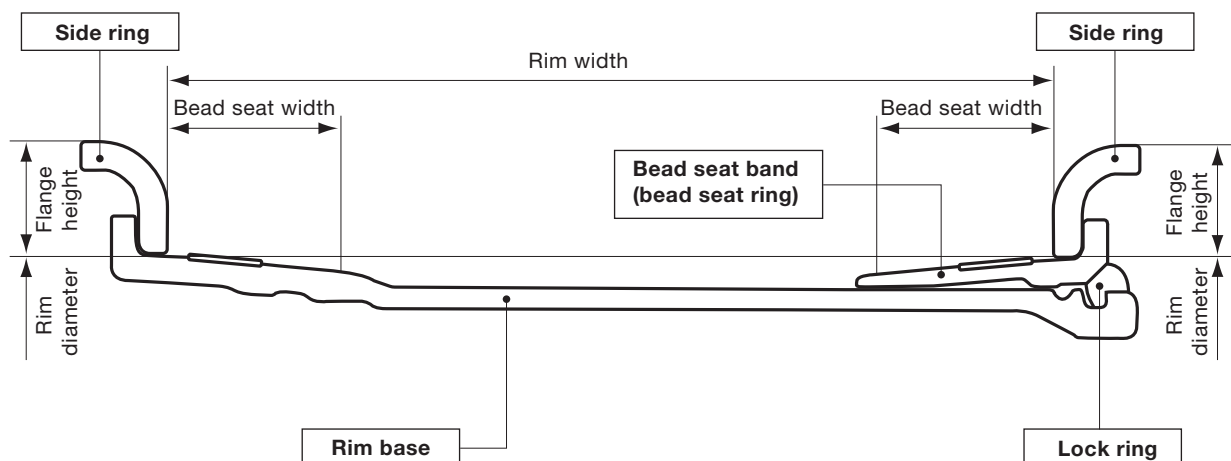

4. Definitions of rim components

4.2 Names of rim components

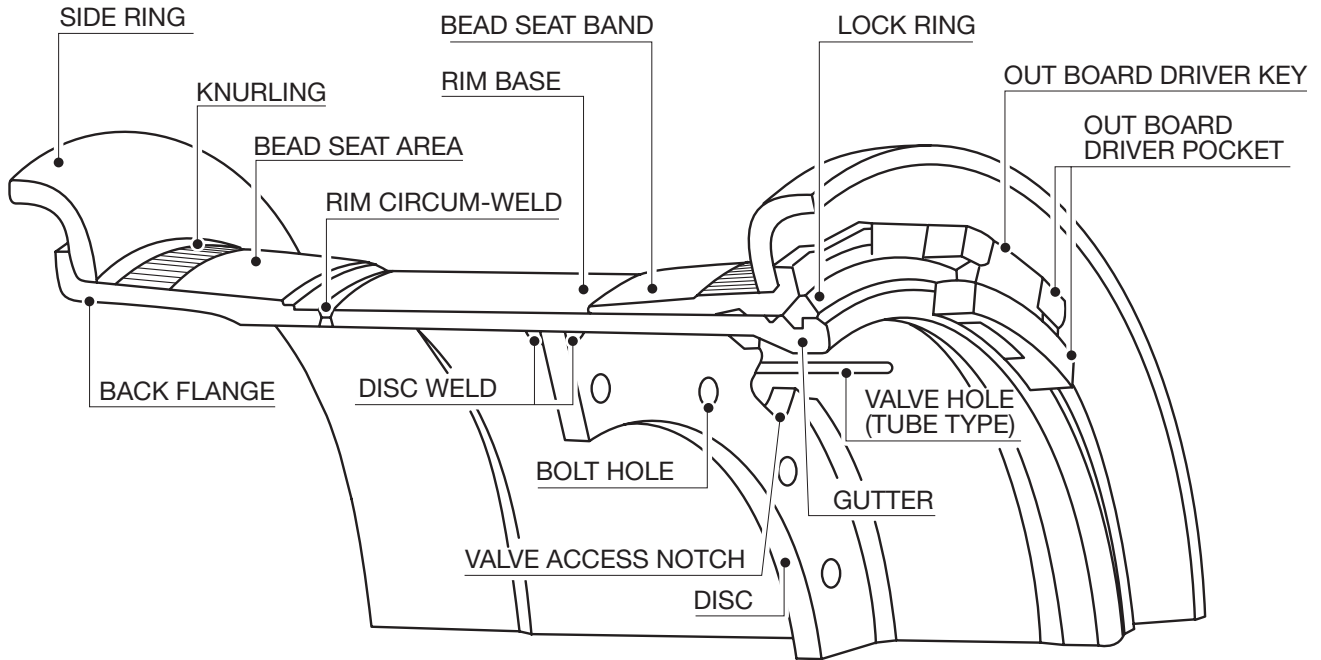

Names of rim component involving an out board driver

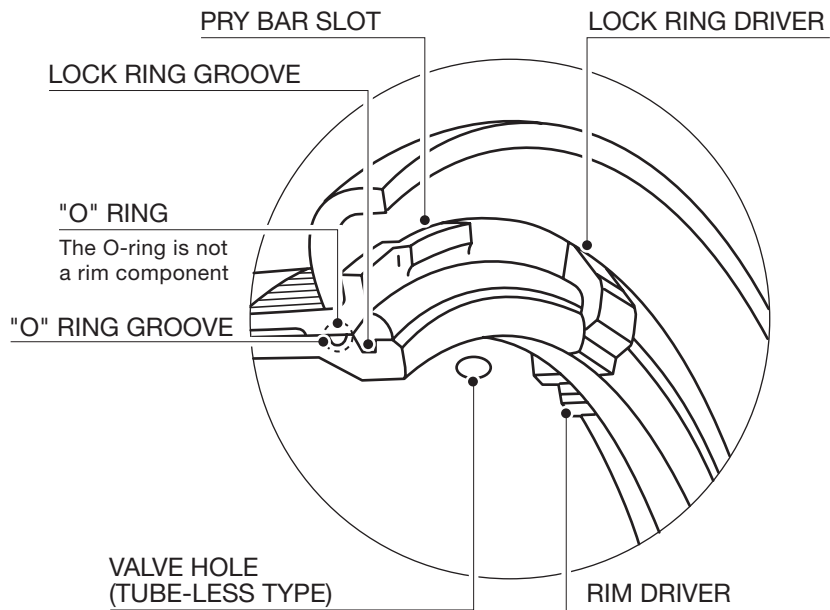

Names of gutter section involving a lock ring driver

5. Markings

5. Markings

Markings clarify the specifications of the rim components.

Workers servicing tyres and rims must fully understand “5.1 Location of markings”, “5.2 Composition of markings”, as well as “5.3 Rim component specifications”, and must confirm that the combination of rim components is correct.

Correct combinations (matching) of rim components are provided in “6. Matching charts”. Workers servicing tyres and rims should check the markings on the combined rim components and confirm that the combination is correct using the matching chart.



Warning

- Check the markings on the rim components and confirm that they are TOPY products.
- **DO NOT** combine TOPY products with products from other companies. Doing so could cause “explosive separation of the rim” and result in serious injury or death.
- An incorrect combination of rim components can cause explosive separation of the rim and serious injury or death.

5.1 Location of markings

Rim components manufactured by TOPY have markings in the areas shown below. The markings are positioned so they can be visually confirmed even after tyre assembly.

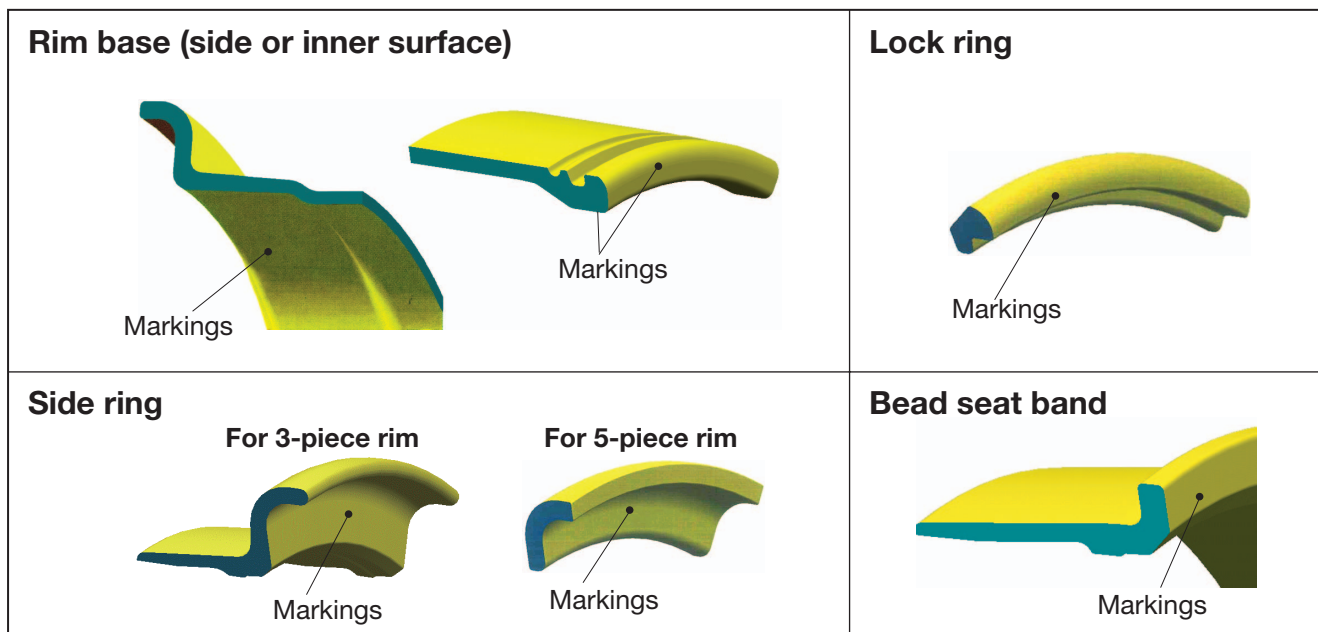

5. Markings

5.2 Composition of markings

Markings on TOPY rim components consist of [month & year of manufacture], [rim component specification], [TOPY (manufacturer)].

For details regarding the aforementioned [rim component specification], refer to “5.3 Rim component specifications”.

Example of markings:	12-06	RM2957EU	TOPY
	[Month & year of manufacture]	[Rim component specification]	[Manufactured by TOPY]
	e.g. manufactured in Dec. 2006	e.g. rim base component, rim width 29 inches, rim diameter 57 inches EU type	

Composition of markings	Marking information
[Month & year of manufacture]	Indicates the month and year in which component was manufactured.
[Rim component specification]	Indicates the rim component specification (component category, size, type). Vital information for confirming combination (matching) of rim components.
[TOPY (manufacturer)]	All TOPY rim components are marked with “TOPY”.

Note: The order of month and year of manufacture, rim component specification, and TOPY in the markings may vary.

5. Markings

5.3 Rim component specifications

When servicing tyres and rims, workers must use the matching charts below and the rim component specification to confirm that the combination of rim components is correct.

- If there are any doubts concerning the interpretation of rim component specifications, please contact your TOPY rim dealer.

Markings on [rim component specification] consist of [rim component category], [size], and [type].

Please refer to “5.3.1 Rim component categories” and “5.3.2 Size and type of rim components” for details.

Example of rim component specification markings :

RM	2525	EM
[Rim component category]	[Size]	[Type]

5.3.1 Rim component categories

The first 2 letters in the [rim component specification] markings indicate the “rim component” classification, as shown in the table below.

Marking	Rim component	Special comments
RM	Rim base	·RM may be omitted ·D or S might be used instead
LR	Lock ring	·Component of 3-piece and 5-piece rim
SR	Side ring	·Component of 3-piece and 5-piece rim
BB	Bead seat band (bead seat ring)	·Component of 5-piece rim

5. Markings

5.3.2 [Size] and [type] of rim components

Details regarding [size] and [type], which are important specifications for rim components, are described below for each rim component (rim base, lock ring, side ring, bead seat band).

(1) Rim base

Example of markings:	RM [Component classification]	2957 [Size]	EU [Type]
----------------------	---	-----------------------	---------------------

■ [Size]

For both of the marking examples in the table below, the rim width and rim diameter are indicated in inches.

Example of [Size] markings	[Size]		Special comments
	Rim width	Rim diameter	
1949	First 2 digits (19) e.g. 19.5 inches	Next 2 digits (49) e.g. 49 inches	In the rim width markings shown below, digits following the decimal point are omitted. 11.25 inches : 11 19.50 inches : 19
29.00×57	Numbers preceding "×" (29.00) e.g. 29 inches	Numbers following "×" (57) e.g. 57 inches	The order of rim width and rim diameter may vary.

■ [Type]

Indicates the type of rim base and identifies the matching lock ring, bead seat band, and side ring.

See "6. Matching charts" for rim component combinations.

(2) Lock ring

Example of markings:	LR [Component classification]	57 [Size]	EU [Type]
----------------------	---	---------------------	---------------------

■ [Size]

Indicates the rim diameter of the matching rim base in inches.

■ [Type]

Indicates the type and identifies the matching rim base and bead seat band.

See "6. Matching charts" for rim component combinations.

5. Markings

(3) Bead seat band

Example of markings:	BB	7557	HS
	[Component classification]	[Size]	[Type]

■ [Size]

Indicates bead seat width and rim diameter of matching rim base in inches.

Example of [Size] markings	[Size]		Special comments
	Bead seat width	Rim diameter	
7557	First 2 digits (75) e.g. 7.5 inches	Next 2 digits (57) e.g. 57 inches	Decimal places are omitted from bead seat width

■ [Type]

Indicates the type and identifies the matching rim base, lock ring, and side ring.
See “6. Matching charts” for rim component combinations.

(4) Side ring

Example of markings:	SR	5063
	[Component classification]	[Size]

■ [Size]

Indicates flange height of side ring and rim diameter of matching rim base in inches.

Example of [Size] markings	[Size]		Special comments
	Flange height	Rim diameter	
5063	First 2 digits (50) e.g. 5.0 inches	Next 2 digits (63) e.g. 63 inches	Decimal places are omitted from flange height

*Special side ring – W type side ring

W type side rings are exclusively for EUW type rim bases and bead seat bands.

The size is followed by a W or SW mark.

See “6. Matching charts” for rim component combinations.

Example of markings for W type side ring :	SR	5063	W or SW
---	-----------	-------------	----------------

6. Matching charts

6. Matching charts

Correctly combining rim components is called “matching”, and the tables of rim component combinations are called “matching charts”.

In this manual, matching lock rings, bead seat bands, and side rings for each rim base type are shown in the matching charts.

Correctly combine (match) rim components according to the “matching charts” shown starting on the next page.



Warning

- Check the rim component markings and confirm that the combination of rim components is correct using the matching charts.
The wrong combination could cause “explosive separation of the rim” resulting in serious injury or death to workers and possibly bystanders.
- Confirm tyre and rim combinations with your tyre dealer or confirm using the specifications for tyres and rims.
- If there are any doubts concerning combinations or the matching charts, immediately suspend the work in progress and contact your TOPY rim dealer.

6. Matching charts

EUW TYPE RIM (Rim diameter 63 inches)

Standard tyre	Rim size (Dia×width/ Flange height)	Rim component size and type			
		Rim base	Lock ring	Bead seat band	Side ring
53/80R63	63×36.00/5.0	DM3663EUW	LR63EUS	BB7563HSW	SR5063W
53/80R63	63×36.00/5.0	DM3663EUW	LR63EUS	BB7563HSW	SR5063SW
58/80R63	63×44.00/5.0	DM4463EUW	LR63EUS	BB7563HSW	SR5063W
58/80R63	63×44.00/5.0	DM4463EUW	LR63EUS	BB7563HSW	SR5063SW

EU TYPE (Rim diameter 63 inches)

Standard tyre	Rim size (Dia×width/ Flange height)	Rim component size and type			
		Rim base	Lock ring	Bead seat band	Side ring
55/80R63	63×41.00/5.0	D4163EU	LR63EU	BB7563HS	SR5063
58/80R63	63×44.00/5.0	D4463EU	LR63EU	BB7563HS	SR5063

EU TYPE (Rim diameter 57, 51 inches)

Standard tyre	Rim size (Dia×width/ Flange height)	Rim component size and type			
		Rim base	Lock ring	Bead seat band	Side ring
30.00R51	51×22.00/4.5	RM2251EU	LR51EU	BB7551HS	SR4551
33.00R51	51×24.00/5.0	RM2451EU	LR51EU	BB7551HS	SR5051
36.00R51	51×26.00/5.0	RM2651EU	LR51EU	BB7551HS	SR5051
37.00R57	57×27.00/6.0	RM2757EU	LR57EU	BB7557HS	SR6057
40.00R57, 46/90R57	57×29.00/6.0	RM2957EU	LR57EU	BB7557HS	SR6057
46/90R57	57×32.00/6.0	RM3257EU	LR57EU	BB7557HS	SR6057
48/95R57	57×32.00/6.5	RM3257EU	LR57EU	BB7557HS	SR6557
49.5/80-57, 50/80-57	57×36.00/6.0	RM3657EU	LR57EU	BB7557HS	SR6057
55/80R57	57×44.00/5.0	RM4457EU	LR57EU	BB7557HS	SR5057
55.5/80-57	57×44.00/6.0	RM4457EU	LR57EU	BB7557HS	SR6057

EJ TYPE (Rim diameter 51 inches)

Standard tyre	Rim size (Dia×width/ Flange height)	Rim component size and type			
		Rim base	Lock ring	Bead seat band	Side ring
30.00-51	51×22.00/4.5	RM2251EJ	LR51EJ	BB7551HS	SR4551
33.00-51	51×24.00/5.0	RM2451EJ	LR51EJ	BB7551HS	SR5051
36.00-51	51×26.00/5.0	RM2651EJ	LR51EJ	BB7551HS	SR5051
50/65-51	51×40.00/4.5	RM4051EJ	LR51EJ	BB7551HS	SR4551

6. Matching charts

EV TYPE (Rim diameter 49, 35, 33 inches)

Standard tyre	Rim size (Dia×width/Flange height)	Rim component size and type			
		Rim base	Lock ring	Bead seat band	Side ring
18.00-33	33×13.00/2.5	RM1333EV	LR33EV	BB5533EV	SR2533
35/65-33	33×28.00/3.5	RM2833EV	LR33EV	BB5533EV	SR3533
21.00-35	35×15.00/3.0	RM1535EV	LR35EV	BB5535EV	SR3035
24.00-35	35×17.00/3.5	RM1735EV	LR35EV	BB5535EV	SR3535
24.00R49	49×17.00/3.5	RM1749EV	LR49EV	BB5549EV	SR3549
27.00R49	49×19.50/4.0	RM1949EV	LR49EV	BB5549EV	SR4049

ES TYPE (Rim diameter 57, 45, 39 inches)

Standard tyre	Rim size (Dia×width/Flange height)	Rim component size and type			
		Rim base	Lock ring	Bead seat band	Side ring
41.25/70-39	39×32.00/4.5	RM3239ES	LR39ES	BB5539ES	SR4539
45/65-45	45×36.00/4.5	RM3645ES	LR45ES	BB5545ES	SR4545
65/65-57	57×52.00/6.0	D5257EU	LR1057ES	BB1057ES	SR6057

* For rim size 57X52.00/6.0, although the EU type rim base is used, combine with ES type lock ring and ES type bead seat band.

EMR TYPE (Rim diameter 45, 39 inches)

Standard tyre	Rim size (Dia×width/Flange height)	Rim component size and type			
		Rim base	Lock ring	Bead seat band	Side ring
33.5-39	39×28.00/4.0	RM2839EMR	LR39EM	BB5539EV	SR4039
40/65-39	39×32.00/4.5	RM3239EMR	LR39EM	BB5539EV	SR4539
45/65-45	45×36.00/4.5	RM3645EMR	LR45EM	BB5545EV	SR4545

EMH TYPE (Rim diameter 33, 29 inches)

Standard tyre	Rim size (Dia×width/Flange height)	Rim component size and type			
		Rim base	Lock ring	Bead seat band	Side ring
29.5-29	29×25.00/3.5	RM2529EMH	LR29EM	BB5529EM	SR3529
18.00-33	33×13.00/2.5	RM1333EMH	LR33EM	BB4033EM	SR2533
24.00-33	33×17.00/3.5	RM1733EMH	LR33EM	BB5533EM	SR3533
35/65-33	33×28.00/3.5	RM2833EMH	LR33EM	BB5533EM	SR3533
33.5-33	33×28.00/4.0	RM2833EMH	LR33EM	BB5533EM	SR4033

6. Matching charts

EM TYPE (Rim diameter 25 inches)

Standard tyre	Rim size (Dia×width/Flange height)	Rim component size and type			
		Rim base	Lock ring	Bead seat band	Side ring
14.00-25	25×10.00/1.5	RM1025EM(D)	LR25EM(D)	BB4025EM(D)	SR1525
16.00-25	25×11.25/2.0	RM1125EM(D)	LR25EM(D)	BB4025EM(D)	SR2025
18.00-25	25×13.00/2.5	RM1325EM(D)	LR25EM(D)	BB4025EM(D)	SR2525
17.5-25	25×14.00/2.0	RM1425EM(D)	LR25EM(D)	BB4025EM(D)	SR2025
21.00-25	25×15.00/3.0	RM1525EM(D)	LR25EM(D)	BB4025EM(D)	SR3025
24.00-25	25×17.00/3.5	RM17255EM(D)	LR25EM(D)	BB5525EM(D)	SR3525
20.5-25	25×17.00/2.0	RM17254EM(D)	LR25EM(D)	BB4025EM(D)	SR2025
23.5-25	25×19.50/2.5	RM1925EM(D)	LR25EM(D)	BB4025EM(D)	SR2525
26.5-25	25×22.00/3.0	RM2225EM	LR25EM	BB5525EM	SR3025
29.5-25	25×25.00/3.5	RM2525EM	LR25EM	BB5525EM	SR3525
30/65R25	25×24.00/3.0	RM2425EM	LR25EM	BB5525EM	SR3025
18.00-33	33×13.00/2.5	RM1333EM	LR33EM	BB4033EM	SR2533

*(D) indicates Lock Ring Driver type rims.

WI TYPE (Rim diameter 24, 20 inches)

Standard tyre	Rim size (Dia×width/Flange height)	Rim component size and type		
		Rim base	Lock ring	Side ring
14.00-20	20×10.00WI	RM1020WI	LR20WIA	SR20WI
12.00-24	24×8.50V-W	RM8524VW	LR24WIA	SRWV24
14.00-24	24×10.00WI	RM1024WI	LR24WIA	SR24WI

WI TYPE (for tubeless tyre, rim diameter 24, 20 inches)

Standard tyre	Rim size (Dia×width/Flange height)	Rim component size and type		
		Rim base	Lock ring	Side ring
14.00-20	20×10.00WI-T	RM1020WI-T	LR20WIA-T	SR20WI-T
12.00-24	24×8.50V-W-T	RM8524VW-T	LR24WIA-T	SRWV24-T
14.00-24	24×10.00WI-T	RM1024WI-T	LR24WIA-T	SR24WI-T

TG Rim and Others (Rim diameter 24, 25 inches)

Standard tyre	Rim size (Dia×width/Flange height)	Rim component size and type		
		Rim base	Lock ring	Side ring
13.5-20	20×11.00TG	RM1120TG	LR20TG	SR20TG
12.00-24, 13.00-24	24×8.00TG	RM8024TG	LR8024	SR8024
14.00-24, 16.00-24	24×10.00VA	RM1024	LR1024	SR8024
15.5-25	25×12.00	RM1225	LR1225	SR1225
15.5-25	25×12.00/1.3(A)	RM1225A	LR25GR	SR1225A
17.5-25	25×14.00/1.5	RM1425	LR25GR	SR1425
14.00-25	25×10.00/1.5	RM1025	LR25GR	SR1025
20.5-25	25×17.00/1.7	RM1725-1.7	LR25GR	SR1725-1.7

7. Examples of potentially hazardous matches

7. Examples of potentially hazardous matches



Warning

- If you are assembling these combinations, be especially careful. Incorrect assembly can result in serious injury or death.
- If you have any questions about safe combinations, stop working and contact your TOPY rim dealer.

(1) EUW, EU type rim with rim diameter 63 inches

The contact shapes of rim components (rim bases, lock rings, bead seat bands, side rings) for EUW type and EU type rims vary. Always make sure you assemble them correctly.

■ Diagrams showing the correct assembly of EUW type rim components and EU type rim components

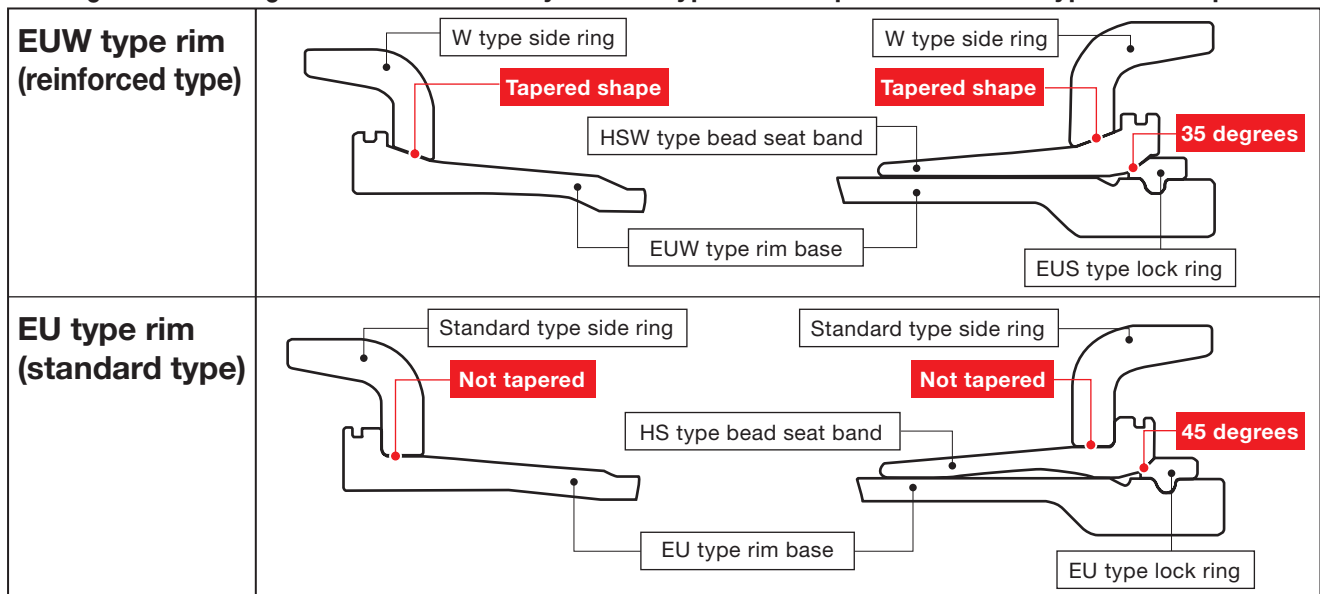

■ Characteristics of EUS, EU type lock rings of 63-inch rim diameter

Verify the grooves and markings to distinguish between EUS type and EU type lock rings of 63-inch rim diameter.

Type of lock ring	LR63EUS	LR63EU
Type of matching rim	EUW type	EU type
Lock ring angle	35 degrees	45 degrees
Cross-sectional shape	<p>Grooves for identification</p>	
Identification	<p>Marking: EUS Shape: Has grooves for identification</p>	<p>Marking: EU Shape: No grooves for identification</p>



Warning

- Check the rim component markings and confirm that the combination of rim components is correct using the matching charts.
- Incorrect assembly could lead to a fatal accident. Always verify the compatibility of components before assembling.



7. Examples of potentially hazardous matches

(2) Rim base and lock ring combination

For rim diameters 63, 57, 51 inches

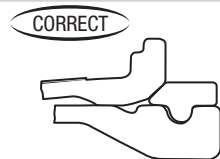
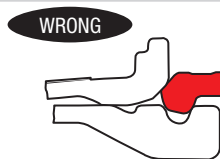
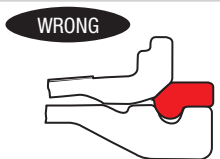
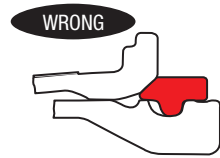
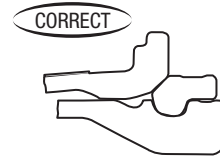
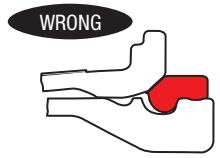
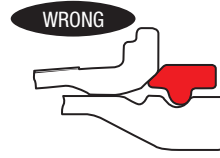
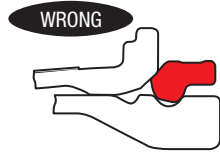
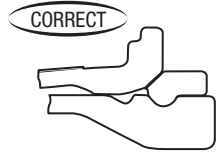
On gutters of EU type and EJ type rim bases, or on gutters of other manufacturers rim base, the shape of the lock ring groove differs. Ensure that they are combined with the correct lock ring.

Gutter band	Lock ring		
	EU type	EJ type	PHASE II <small>(manufactured by another company Here to refer to the note below)</small>
EU type	 CORRECT	 WRONG	 WRONG
EJ type	 WRONG	 CORRECT	 WRONG
PHASE II <small>(manufactured by another company Here to refer to the note below)</small>	 WRONG	 WRONG	 CORRECT

 : Correct combination  : Wrong combination

* **PHASE II:** PHASE II is manufactured by another company. As far as TOPY Industries is aware of, this is the current name by which this lock ring is referred to in the industry. Please note that the name and/or shape may change in the future.



Warning





- Check the rim component markings and confirm that the combination of rim components is correct using the matching charts.
- **NEVER** mix TOPY rim components with PHASE II type rim components manufactured by another company. Incorrect assembly could lead to a serious injury or death. Always verify the compatibility of components before assembling.

7. Examples of potentially hazardous matches

(2) Rim base and lock ring combination (cont'd)

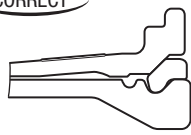
For rim diameter 49, 35, 33 inches

On gutter of EV type and EM type rim bases, the shape of the lock ring groove differs. Make sure that they are combined with the correct lock ring.

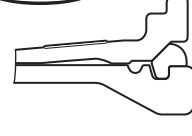
Gutter		Lock ring	
		EV type	EM type
EV type			
EM type			

 : Correct combination  : Wrong combination



Warning

- Check the rim component markings and confirm that the combination of rim components is correct using the matching charts.
- Incorrect assembly could result in serious injury or death. Always verify the compatibility of components before assembling.

7. Examples of potentially hazardous matches

(3) Lock ring and bead seat band combination

For rim diameter 57 inches

On ES type and EU type lock rings, the contact angle with the bead seat band differs. Make sure that they are combined with the correct bead seat band.

Lock ring \ Bead seat band	ES type 35°	EU type 45°
ES type 35°	<p>CORRECT</p>	<p>WRONG</p>
HS type 45°	<p>WRONG</p>	<p>CORRECT</p>

: Correct combination : Wrong combination

■ Characteristics of ES, EU type lock rings for nominal diameter 57 inches

Type of lock ring	LR1057ES	LR57EU
Matching bead seat band type	ES type	HS type
Lock ring angle	35 degrees	45 degrees
Cross-sectional shape	<p>Grooves for identification</p>	
Identification	<p>Marking: ES Shape: Has grooves for identification</p>	<p>Marking: EU Shape: No grooves for identification</p>



Warning

- Check the rim component markings and confirm that the combination of rim components is correct using the matching charts.
- Incorrect assembly could result in serious injury or death. Always verify the compatibility of components before assembling.

7. Examples of potentially hazardous matches

(3) Lock ring and bead seat band combination (cont'd)

For rim diameters 45, 39 inches

On ES type and EM type lock rings, the contact angle with the bead seat band differs. Make sure that they are combined with the correct bead seat band.

		Lock ring	
		ES type	EM type
Bead seat band	ES type		
	EV type		

: Correct combination : Wrong combination

■ Characteristics of ES, EM type lock rings for rim diameters 45, 39 inches

Type of lock ring	LR45ES, LR39ES	LR45EM, LR39EM
Matching bead seat band type	ES type	EV type
Lock ring angle	35 degrees	45 degrees
Cross-sectional shape		
Identification	Marking: ES	Marking: EM



Warning

- Check the rim component markings and confirm that the combination of rim components is correct using the matching charts.
- Incorrect assembly could lead result in serious injury or death. Always verify the compatibility of components before assembling.

7. Examples of potentially hazardous matches

(4) Facing of lock ring

The correct installation of the locking ring can only be achieved if the markings on the locking ring can be seen before, during, and after installation.

If the locking ring is installed back to front it will not interface properly with the gutter band and there is a risk of the locking ring dislodging under pressure.

<Typical example> For WI type lock ring

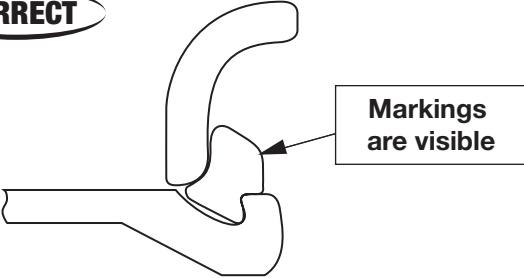
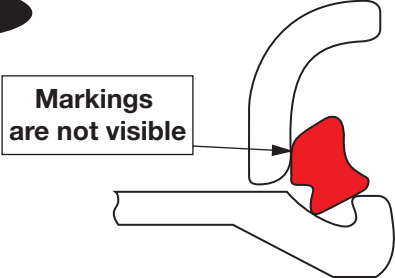
Correct facing	Wrong facing
<p>CORRECT</p> 	<p>WRONG</p> 



Warning

- Prior to installing the locking ring, confirm that the locking marking is visible so that the installation can be carried out correctly.
- If the locking ring is installed back to front, the markings are not visible, and continuing assembly could result in an explosion and serious injury or death.

8. Procedures for servicing tyres and TOPY rims

8. Procedures for servicing tyres and TOPY rims



Warning

- Servicing tyres and rims can be very dangerous. Failing to heed the warnings could result in serious injury or death.
- Servicing of tyres and rims should be carried out only by workers who have received adequate training from a qualified supervisor on safe handling of tyres and rims. This training must include reading this manual completely.
- Tyres should be deflated while standing outside the range of the “hazardous trajectory” shown by the arrows in the diagram below. Exercise extreme caution as the direction of the trajectory may widen.
- While deflating, **DO NOT** allow other workers or third parties to approach the area of the trajectory.
- Check the “Tyre and Rim Handling Manual” published by the tyre manufacturer for information on work and inspections, etc. involving tyre handling.
- There are several types of tools for servicing work. Be sure you have a proper understanding of how the tools are used and carry out the work in accordance with the proper procedure.
- Ensure that protective equipment is worn when servicing tyres and rims.
(Wear gloves, safety shoes, safety glasses, face protection, earplugs, hard hat, etc.)
- If there are any doubts during demounting, mounting, or inflating tyres and rims, immediately stop the work in progress and seek instruction from a supervisor.

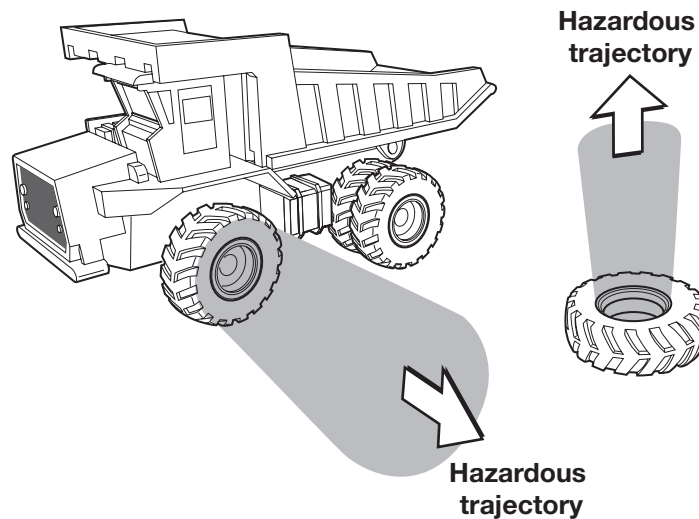

8.1 How to demount tyre from TOPY 3-piece rim

[Required tools]

- Valve tool •Wire for valve cleaning •Wire brush
- Tyre lever for tyre mount/demount (confirm specifications of tool type with your tyre dealer)
- Lifting equipment (crane, chains, nylon sling, forklift, tyre handler, etc.)

STEP 1

Release all air

① Prior to demounting tyre from rim, release all air by removing the valve core housing with the valve tool.

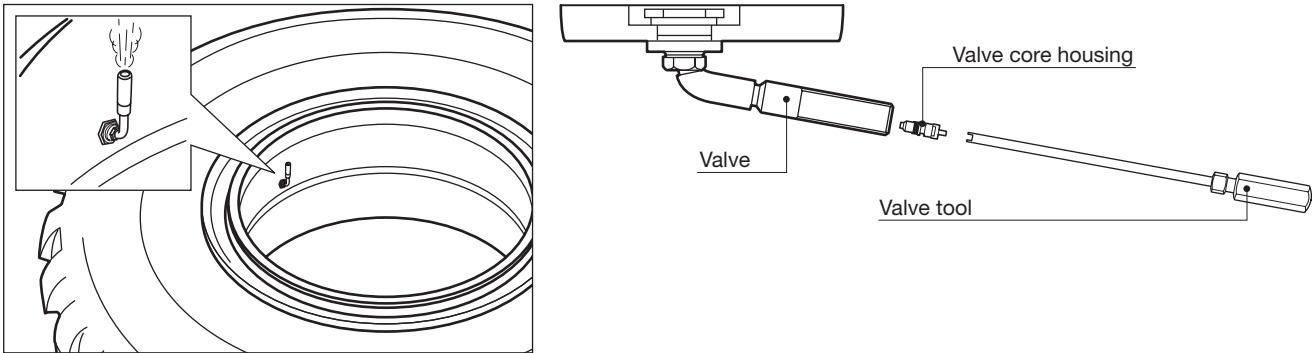

Warning

- First, remove the valve core and release all air from the tyre.
- Be aware of the trajectory of the valve core as it may shoot out during its removal.
- If there is any foreign matter inside the valve, the air will not be released. Insert wire, etc. into the valve to clear away foreign matter.
- When removing tyre and rim from a vehicle, prior to removing the parts (clamps, nuts, etc.), secure the rim base accessories (extension valve fixing brackets, etc.) and rim base to the vehicle and release all air from the tyre.
- When demounting outer tyres and rims of dual assemblies, make sure you release all air from the inner tyres as well.
- Tyres should be deflated outside the range of the “hazardous trajectory” shown by the arrow in the diagram below. Exercise extreme caution as the range of the trajectory may widen.
- During deflation work, **DO NOT** allow other workers or third parties to approach the area of the trajectory.
- When releasing air, stand in a safe location as foreign matter or frozen particles inside tyre might be discharged.
- Do not allow high pressure air to hit skin.

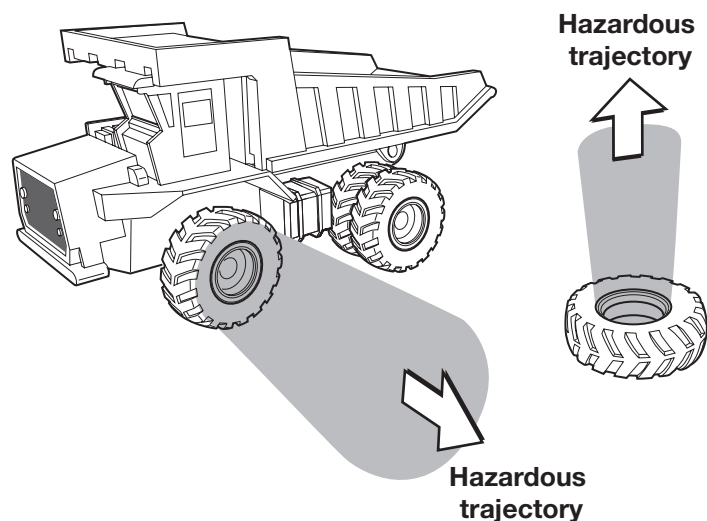

8.1 How to demount tyre from TOPY 3-piece rim

**STEP
2**

Set up the tyre and rim

- After fully releasing the air, place the tyre and rim on the ground with the gutter side facing up.

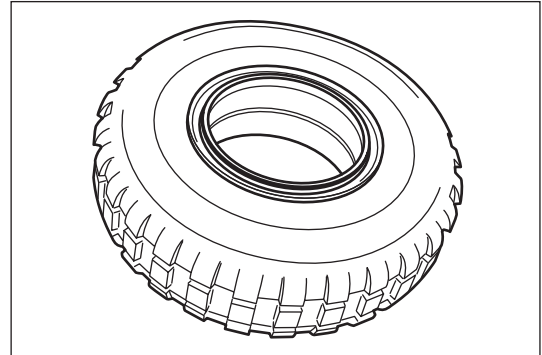
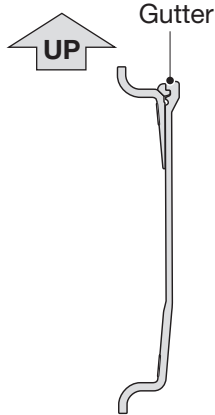

Warning

- Because this work involves handling heavy items, where necessary, you must use appropriate lifting equipment.
- When moving tyres and rims, be careful to avoid accidental drops or falls that could injure you or others in the vicinity.

**STEP
3**

Detach tyre bead seat from side ring

- Insert the tyre lever between the tyre bead and the side ring. Unseat the bead from the side ring by using the lever to push the tyre down around the entire circumference.

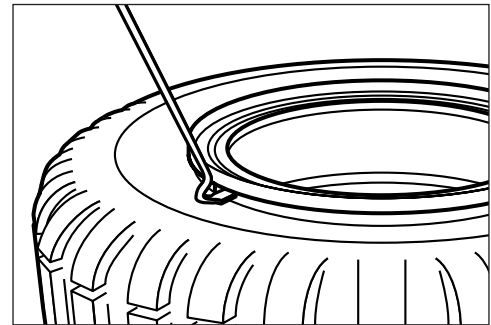

Warning

- When mounting and demounting tyres, maintain a firm grip on the tyre lever as it may jerk loose and cause injury.

8.1 How to demount tyre from TOPY 3-piece rim

**STEP
4**

Remove lock ring

- ① Use the tyre lever to lift one end of the locking ring from the locking ring groove.
- ② With a second tyre lever continue to dislodge the locking ring around the circumference of the rim until the locking ring is free from the assembly.

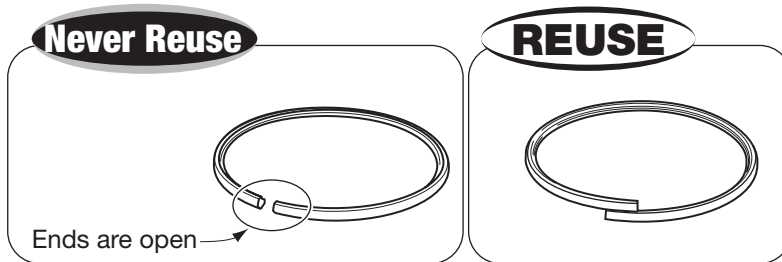
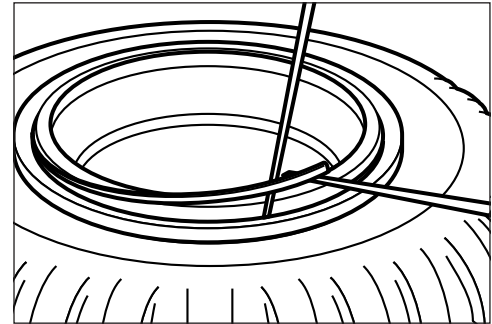

Warning

- Discard lock rings with open ends (ends aren't touching) as they will not set correctly (see above) and could result in serious injury or death.
- When removing the lock ring, **DO NOT** spread the ends excessively as they will no longer touch and will have to be discarded.
- Keep fingers away from lock ring.
- Be careful when removing the lock ring as it may literally fly off as it is being freed.
- Maintain a firm grip on the tyre lever as it may be thrown and cause injury.

8.1 How to demount tyre from TOPY 3-piece rim

**STEP
5**

Remove O-ring

- ① Use the tyre lever to push down on the side ring so that the O-ring may be removed. Remove the O-ring.

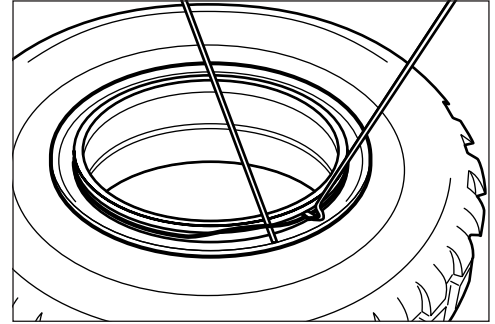

Warning

- Keep fingers away from side ring.
- When mounting and demounting tyres, maintain a firm grip on the tyre lever as it may be jerk loose and cause injury.

Notice

Once used, O-rings become deformed and can result in air leaks. Used O-rings should be cut and discarded.

**STEP
6**

Remove side ring

- ① Use the tyre lever to remove the side ring.

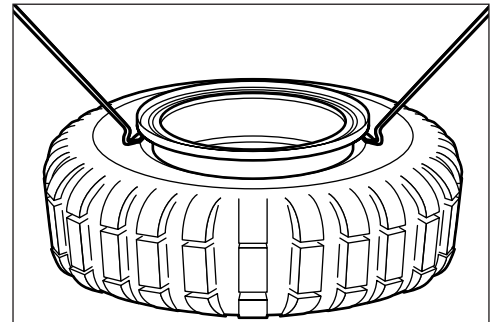

Warning

- Keep fingers away from side ring.
- When mounting and demounting tyres, maintain a firm grip on the tyre lever as it may be jerk loose and cause injury.
- Be careful not to drop components on your feet.

8.1 How to demount tyre from TOPY 3-piece rim

**STEP
7**

Turn over tyre and rim

- ① Use lifting equipment to turn over the tyre and rim, and place them on the ground.

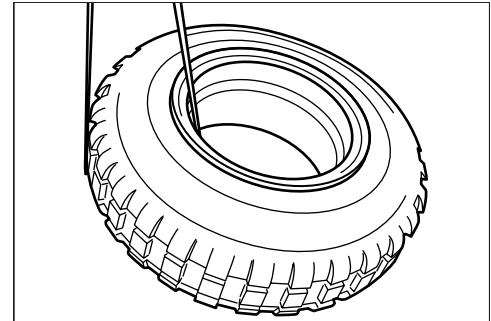

Warning

- Because this work involves handling heavy items, where necessary, you must use appropriate lifting equipment.
- When moving tyres and rims, be careful to avoid accidental drops or falls that could injure you or others in the vicinity.

**STEP
8**

Detach tyre bead from rim base, and remove rim base.

- ① As in Step 3, insert the tyre lever between the tyre bead and the rim base.
- ② Push down the tyre around the entire circumference, and detach tyre bead from the rim base.
- ③ Remove the rim base.

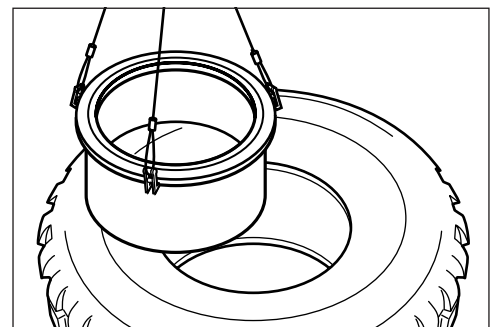

Warning

- Because this work involves handling heavy items, where necessary, you must use appropriate lifting equipment.
- When moving tyres and rims, be careful to avoid accidental drops or falls that could injure you or others in the vicinity.
- Be careful not to get your fingers caught.
- When mounting and demounting tyres, maintain a firm grip on the tyre lever as they may jerk loose and cause injury.

8.2 How to mount tyre onto TOPY 3-piece rim

[Required tools]

- Valve tool •Wire for cleaning valve core •Tyre seating blocks
- Tyre lever for tyre mount/demount (confirm specifications of tool type with your tyre dealer)
- Soft metal or hard plastic hammer (not steel)
- Lifting equipment (crane, chains, nylon sling, forklift, tyre handler, etc.)
- Lubricant for tyre mounting (product recommended by tyre dealer)
- Wire brush •Air gauge •Air chuck

STEP 1

Confirm tyre and rim component combination

- ① Check tyre size and markings on rim base, and make sure that the combination is correct.
- ② Check markings on rim components and matching charts, and make sure that the combination is correct.



Warning

- Confirm tyre and rim combinations with your tyre dealer or confirm using the specifications for tyres and rims.
- Check the rim component markings and confirm that the combination of rim components is correct using the matching charts. The wrong combination could cause “explosive separation of the rim” resulting in severe injury or death to workers and bystanders.
- **DO NOT** combine TOPY rim components with rim components manufactured by other companies.
- If there are any doubts concerning combinations or matching charts, immediately suspend the work in progress and contact your TOPY rim dealer.

STEP 2

Clean rim components and check condition

- ① Clean rim components with a wire brush so that examination, maintenance, and mounting can be done correctly.
- ② Check that there is no deformation, bent, cracking, wear, corrosion, or damage on the rim components.

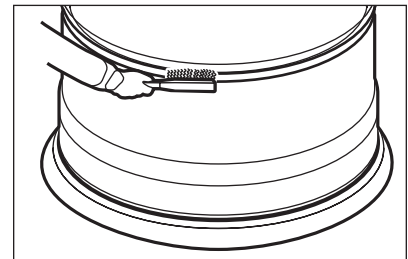

Warning

- Discard any rim components that are deformed, bent, cracked, weared corroded, or damaged, or are suspected of being so, and replace them with undamaged components.
- Discard any lock rings with open ends (ends aren't touching).
- **DO NOT** make modifications that change the product specifications.
- **DO NOT** make modifications involving welding, heating, soldering, etc. Such modifications could lead to the deformation as well as the deterioration of the strength and structural integrity of the rim components.

Notice

If there's any foreign matter, etc. adhering to the lock ring grooves on the rim base or to O-ring grooves, proper assembly will not be possible and air leaks will occur. Make sure all grooves are clean before assembly.

8.2 How to mount tyre onto TOPY 3-piece rim

**STEP
3**

Recoat

- ① Recoat any areas where the anti-corrosive oil or paint is peeling.



Caution

- Anti-corrosive oil and paint may contain toxic ingredients. Follow any safety instructions provided by the manufacturers of the anti-corrosive oil or paint.
- Depending on the vehicle, some parts have certain areas that may be uncoated in order to prevent loosening of parts attaching the rim base to the vehicle (clamps, nuts, etc.) and slipping of rim components, etc. If you're not sure, check with the vehicle manufacturer or your TOPY rim dealer.

**STEP
4**

Set up rim base and install valve

- ① Place rim base on rim base stand with gutter side up.
- ② Install valve.

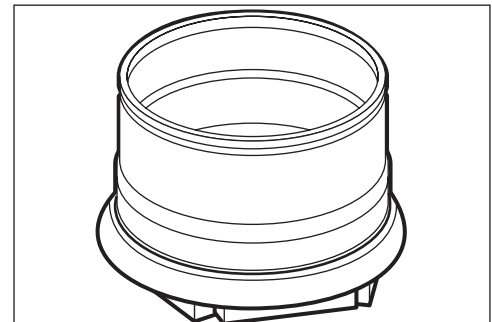

Warning

- Because this work involves handling heavy items, where necessary, you must use appropriate lifting equipment.
- When moving rim components, be careful to avoid accidental drops or falls that could injure you or others in the vicinity.
- For valve selection and installation, follow instructions in the manuals provided by your tyre dealer and valve manufacturer. If in doubt, contact the dealer or manufacturer for guidance.

**STEP
5**

Confirm absence of tyre defects

- ① Confirm absence of tyre defects.



Warning

- Check with tyre dealer to confirm that there are no tyre defects. Using defective tyres could result in tyre failure while you are mounting the tyre and rim or during use, resulting in tyre separation and possible severe injury or death.

8.2 How to mount tyre onto TOPY 3-piece rim

**STEP
6**

Mount tyre on rim base

- ① Apply a vegetable oil-based lubricant to both tyre bead seats.
- ② Place tyre on rim base.

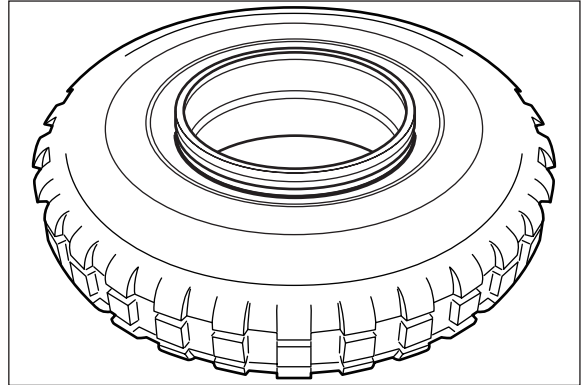

Notice

- **DO NOT** apply tyre lubricant to areas other than where the rim components come in contact with the tyre. Doing so could cause circumferential slippage between rim components when the vehicle is being driven.
- Consult your tyre dealer when selecting tyre lubricant.



Warning

- Because this work involves handling heavy items, correctly use lifting equipment when necessary.
- When moving rim components, be careful to avoid accidental drops or falls that could injure you or others in the vicinity.

**STEP
7**

Fit side ring

- ① Insert side ring into rim base and fit edge section to tyre bead.

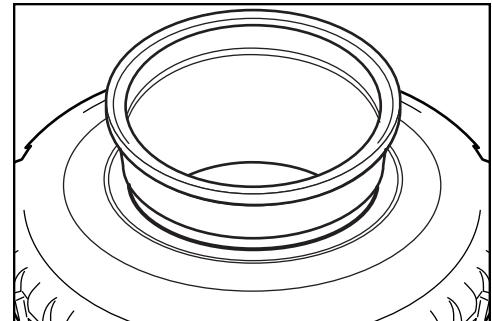

Caution

- Keep fingers away from side ring.

8.2 How to mount tyre onto TOPY 3-piece rim

STEP
8

Fit O-ring

- ① Apply lubricant to new O-ring and install it in the O-ring groove.

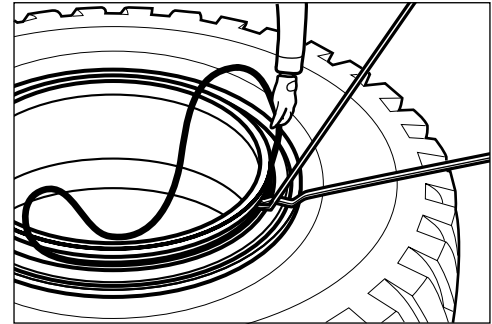

Caution

- Keep fingers away from side ring.

Notice

- Check with your tyre dealer for O-ring specifications or when selecting lubricant.
- Be careful not to twist the O-ring.

8.2 How to mount tyre onto TOPY 3-piece rim

**STEP
9**

Fit lock ring

- ① Place the end of the lock ring into the lock ring groove in the rim base. Use the tyre lever to successfully install the lock ring around the entire circumference.
- ② Starting opposite the locking ring gap, lightly tap the locking ring with a soft metal or hard plastic hammer in both directions back to the locking ring gap to ensure the locking ring is clamped into the locking ring groove.

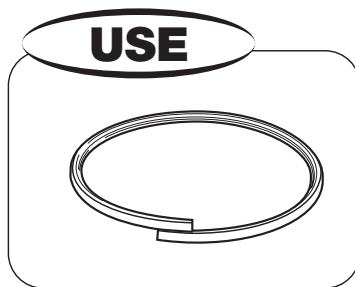
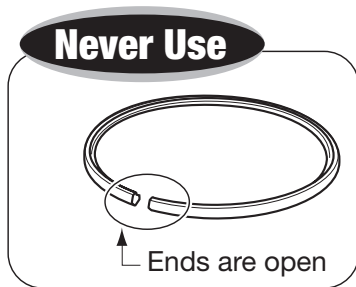
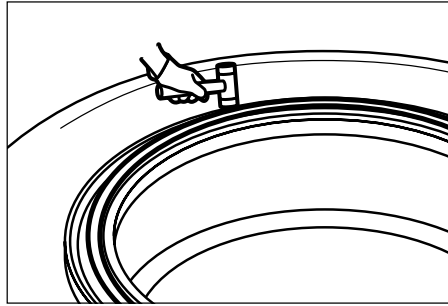
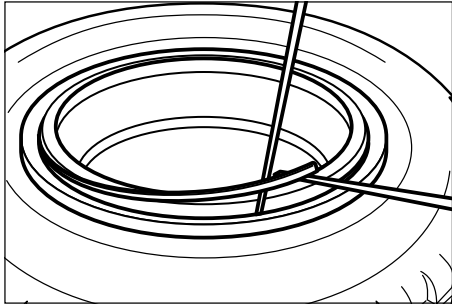

Warning

- **DO NOT** use lock rings with open ends (ends aren't touching).
- Check the facing of the lock ring. The lock ring is installed correctly if its markings are visible after tyre assembly.
- **DO NOT** use a steel mallet.



Caution

- Be careful when handling the lock ring as it may fly off.
- Be careful not to get your fingers caught.

8.2 How to mount tyre onto TOPY 3-piece rim

**STEP
10**

Confirm that rim components are assembled correctly

- ① Make sure the combinations (matching), facings, and positions of rim components are correct.



Warning

- Recheck the tyre and rim component combinations (matching) and make sure they are correct.
- Recheck the facing of the lock ring and make sure it is installed correctly and is securely in the lock ring groove.
- **DO NOT** inflate, hammer, weld or solder to position the rim components. Doing so can lead to the deformation as well as the deterioration of the strength and structural integrity of the rim components.

**STEP
11**

Inflating the tyre and rim

- ① Wherever possible, place tyre and rim inside a tyre inflation safety cage, then inflate tyre. During inflation, keep away from the tyre.
- ② When tyre has been inflated to a pressure of approximately 35kPa (5psi), check assembly of tyre and rim components.
- ③ If assembled correctly, continue inflating up to the rated value.

Tyre inflation safety cage

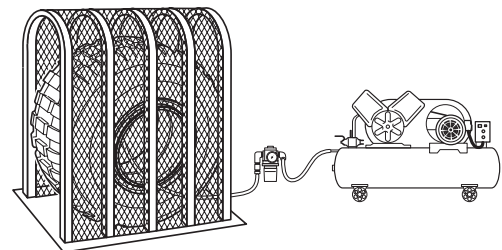

Warning

If assembly has been done incorrectly, inflation could result in an explosive separation of the rim. This separation could result in serious injury or death to you or bystanders. Workers and persons responsible for supervising the work must comply strictly with the following warnings.

- Wherever possible, ensure that the work is carried out with the tyre inside a tyre inflation safety cage.
- While inflating, workers and bystanders must always be outside the range of the "hazardous trajectory". Exercise extreme caution as the trajectory may widen.
- During inflation, use an air pressure gauge and regulator valve.
- To ensure that the worker inflating the tyre can remain outside of the "hazardous trajectory", use an air pressure gauge and a hose of adequate length, and use an air chuck.
- During inflation, **DO NOT** allow the air pressure to exceed the pressure recommended by tyre manufacturer.
- If you notice a mistake in the assembly, immediately stop inflation, release the air, and reassemble the tyre and rim components.
- **NEVER** attempt to position the rim components by inflating the tyre.
- Because this work involves handling heavy items, correctly use lifting equipment when necessary.
- When moving rim components, be careful to avoid accidental drops or falls that could injure you or others in the vicinity.
- Lay the assembled and inflated tyre rim so it is flat and stable and not subject to impacts.

Notice

In order to prevent corrosion of the rim components, inflate tyres with dry air.

8.3 How to demount tyre from TOPY 5-piece rim

[Required tools]

- Valve tool •Wire for valve cleaning
- Tyre lever for tyre mount/demount (confirm specifications of tool type with your tyre dealer)
- Lifting equipment (crane, chains, nylon sling, forklift, tyre handler, etc.)
- Hydraulic bead breaker

STEP
1

Release all air

- ① Prior to demounting tyre from rim, release all air by removing the valve core housing with the valve tool.

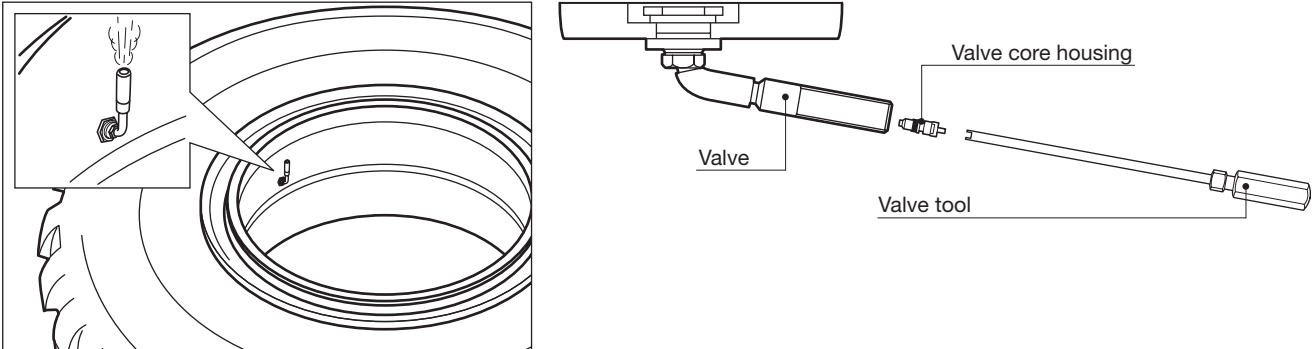

Warning

- First, remove the valve core and release all air from the tyre.
- Be aware of the trajectory of the valve core as it may shoot out during its removal.
- If there is any foreign matter inside the valve, the air will not be released. Insert wire, etc. into the valve to clear away foreign matter.
- When removing tyre and rim from a vehicle, prior to removing the parts (clamps, nuts, etc.), secure the rim base accessories (extension valve fixing brackets, etc.) and rim base to the vehicle and release all air from the tyre.
- When demounting outer tyres and rims of dual assemblies, make sure you release all air from the inner tyres as well.
- Tyres should be deflated outside the range of the “hazardous trajectory” shown by the arrow in the diagram below. Exercise extreme caution as the range of the trajectory may widen.
- During deflation work, **DO NOT** allow other workers or third parties to approach the area of the trajectory.
- When releasing air, stand in a safe location as foreign matter or frozen particles inside tyre might be discharged.
- Do not allow high pressure air to hit skin.

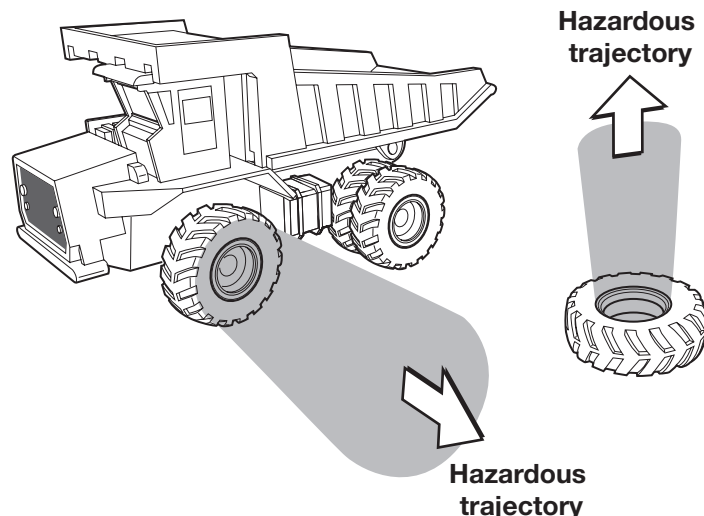

8.3 How to demount tyre from TOPY 5-piece rim

**STEP
2**

Set up tyre and rim

- ① After fully releasing the air, place the tyre and rim on the ground with the gutter side facing up.

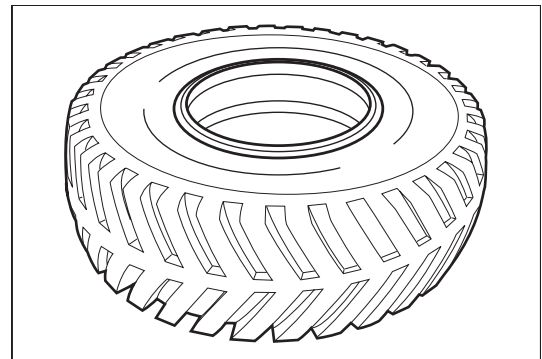
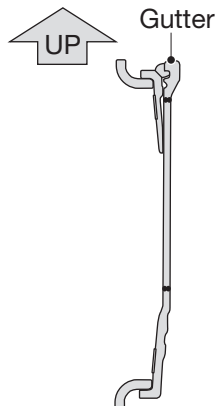

Warning

- Because this work involves handling heavy items, correctly use lifting equipment when necessary.
- When moving tyres and rims, be careful to avoid accidental drops or falls that could injure you or others in the vicinity.

**STEP
3**

Unseat the tyre bead from the bead seat band

- ① Mount bead breaker on bead seat band.
- ② Operate the bead breaker, push down the side ring, and unseat the tyre bead from the bead seat band.

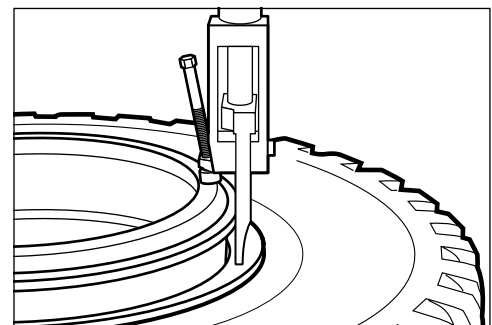

Caution

- Be careful not to get your fingers caught.
- When loading using the bead breaker, stand to one side and carry out the work carefully as the bead breaker could fly off.
- **DO NOT** apply tools to welded areas of the bead seat band, side ring, or rim base. If welds are damaged, discard the component.
- When handling the bead breaker, refer to the instructions provided by the manufacturer.

8.3 How to demount tyre from TOPY 5-piece rim

STEP 4

Remove driver key

- ① For rims fitted with a driver key, remove the driver key.

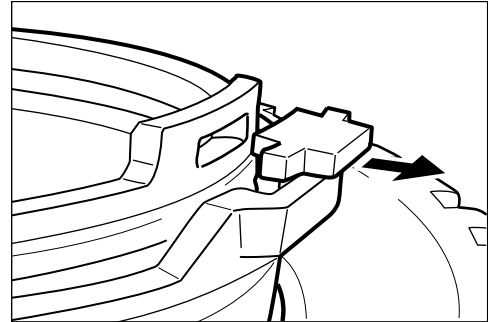

Caution

- Be careful not to get your fingers caught.

STEP 5

Remove lock ring

- ① Use a tyre lever to force the bead seat band free from the locking ring.
- ② Use the tyre lever to leave out one end of the locking ring from the locking groove.
- ③ With a second tyre lever, continue to dislodge the locking ring around the circumference of the rim until the locking ring is free from the assembly.

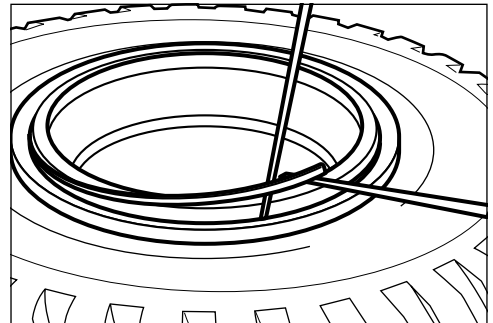

Never Reuse

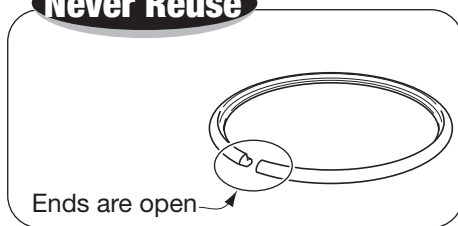

REUSE

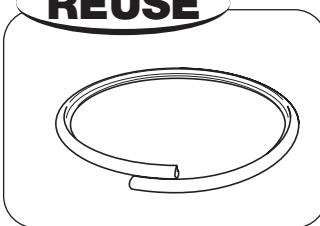

Warning

- Discard lock rings with open ends (ends aren't touching) as they will not set correctly (see above) and could result in serious injury or death.
- When removing the lock ring, **DO NOT** spread the ends excessively as they will no longer touch and will have to be discarded.
- Keep fingers away from lock ring.
- Be careful when removing the lock ring as it may literally fly off as it is being freed.
- Maintain a firm grip on the lever tools as they may jerk loose and cause injury.

8.3 How to demount tyre from TOPY 5-piece rim

**STEP
6**

Remove O-ring

- ① Use the tyre lever to push down on the bead seat band so that the O-ring is freed.
- ② Remove O-ring.

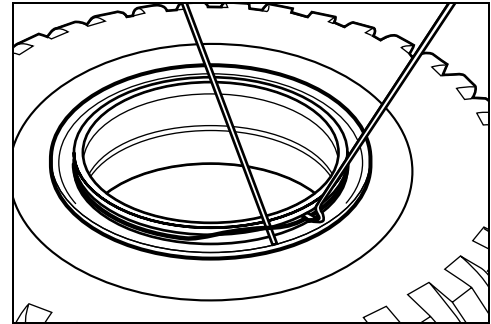

Warning

- Be careful not to get your fingers caught.
- When mounting and demounting tyres, maintain a firm grip on the tyre lever as they may jerk loose and cause injury.

Notice

Once used, O-rings become deformed and can result in air leaks. Used O-rings should be cut and discarded.

**STEP
7**

Remove bead seat band

- ① Use lifting equipment to raise and remove the bead seat band.

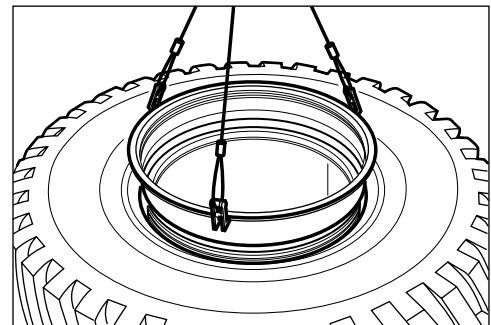

Warning

- Because this work involves handling heavy items, correctly use lifting equipment when necessary.
- When moving tyres and rims, be careful to avoid accidental drops or falls that could injure you or others in the vicinity.

8.3 How to demount tyre from TOPY 5-piece rim

**STEP
8**

Remove side ring

- ① Use lifting equipment to remove the side ring.

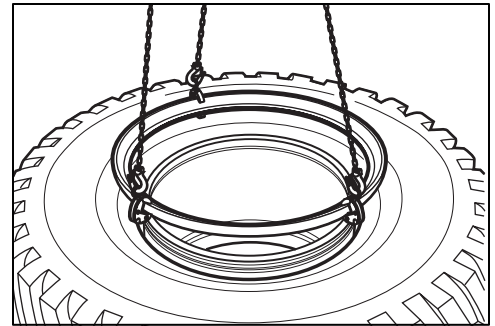

Warning

- Because this work involves handling heavy items, correctly use lifting equipment when necessary.
- When moving tyres and rims, be careful to avoid accidental drops or falls that could injure you or others in the vicinity.

**STEP
9**

Turn over tyre and rim

- ① Use lifting equipment to turn over the tyre and rim, and place them on the ground.

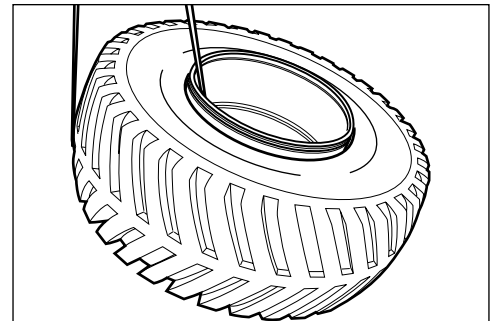

Warning

- Because this work involves handling heavy items, correctly use lifting equipment when necessary.
- When moving tyres and rims, be careful to avoid accidental drops or falls that could injure you or others in the vicinity.

8.3 How to demount tyre from TOPY 5-piece rim

**STEP
10**

Unseat the tyre bead from the rim base

- ① Mount bead breaker on rim base.
- ② As in Step 3, operate the bead breaker, push down the side ring, and unseat the tyre bead from the bead seat band.

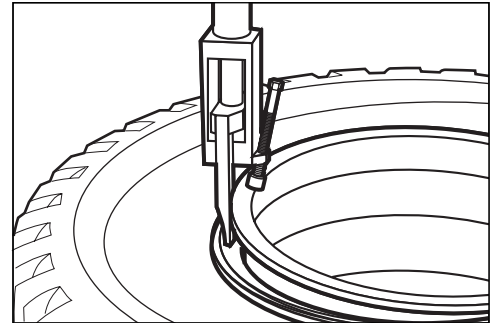

Caution

- Be careful not to get your fingers caught.
- When loading using the bead breaker, stand to one side and carry out the work carefully as the bead breaker could fly off.
- **DO NOT** apply tools to welded areas of the bead seat band, side ring, or rim base. If welds are damaged, discard the component.
- When handling the bead breaker, refer to the instruction provided by the manufacturer.

**STEP
11**

Remove rim base

- ① Use the lifting equipment to remove the rim base.

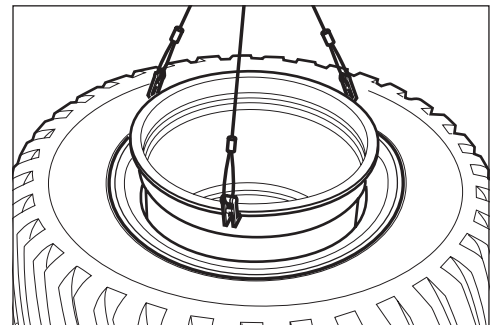

Warning

- Because this work involves handling heavy items, correctly use lifting equipment when necessary.
- When moving tyres and rims, be careful to avoid accidental drops or falls that could injure you or others in the vicinity.

8.3 How to demount tyre from TOPY 5-piece rim

STEP
12

Remove side ring

① Use the lifting equipment to remove the side ring.

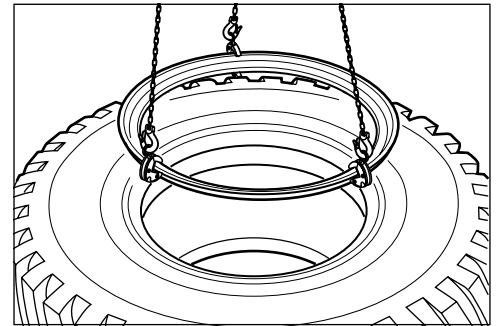

Warning

- Because this work involves handling heavy items, correctly use lifting equipment when necessary.
- When moving tyres and rims, be careful to avoid accidental drops or falls that could injure you or others in the vicinity.

8.4 How to mount tyre onto TOPY 5-piece rim

[Required tools]

- Valve tool •Wire for cleaning valve core •Tyre seating blocks
- Tyre lever for tyre mount/demount (confirm specifications of tool type with your tyre dealer)
- Soft metal or hard plastic hammer (Not steel)
- Lifting equipment (crane, chains, nylon sling, forklift, tyre handler, etc.)
- Lubricant for tyre mounting (product recommended by tyre dealer)
- Wire brush •Air gauge •Air chuck

STEP 1

Confirm tyre and rim component assembly

- ① Check tyre size and markings on rim base, and make sure that the combination is correct.
- ② Check markings on rim components and matching charts, and make sure that the combination is correct.



Warning

- Confirm tyre and rim combinations with your tyre dealer or confirm using the specifications for tyres and rims.
- Check the rim component markings and confirm that the combination of rim components is correct using the matching charts. The wrong combination could cause “explosive separation of the rim” resulting in severe injury or death to workers and bystanders.
- **DO NOT** combine TOPY rim components with rim components manufactured by other companies.
- If there are any doubts concerning combinations or matching charts, immediately suspend the work in progress and contact your TOPY rim dealer.

STEP 2

Clean rim components and check condition

- ① Clean rim components with a wire brush so that examination, maintenance, and mounting can be done correctly.
- ② Check that there is no deformation, bent, cracking, wear, corrosion, or damage on the rim components.

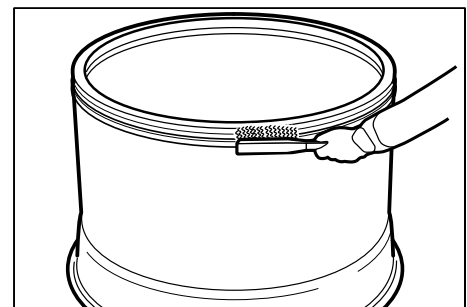

Warning

- Discard any rim components that are deformed, bent, cracked, corroded, worn or damaged, or are suspected of being so, and replace them with undamaged components.
- Discard any lock rings with open ends (ends aren't touching).
- **DO NOT** make modifications that change the product specifications.
- **DO NOT** make modifications involving welding, heating, soldering, etc. Such modifications could lead to the deformation as well as the deterioration of the strength and structural integrity of the rim components.

Notice

If there's any foreign matter, etc. adhering to the lock ring grooves on the rim base or to O-ring grooves, proper assembly will not be possible and air leaks will occur. Make sure all grooves are clean before assembly.

8.4 How to mount tyre onto TOPY 5-piece rim

**STEP
3**

Recoat

- ① Recoat any areas where the anti-corrosive oil or paint is peeling.



Caution

- Anti-corrosive oil and paint may contain toxic ingredients. Follow any safety instructions provided by the manufacturers of the anti-corrosive oil or paint.
- Depending on the vehicle, some parts have certain areas that may be uncoated in order to prevent loosening of parts attaching the rim base to the vehicle (clamps, nuts, etc.) and slipping of rim components, etc. If you're not sure, check with the vehicle manufacturer or your TOPY rim dealer.

**STEP
4**

Set up rim base and install side ring

- ① Place rim base on rim base stand with gutter side up.
- ② Install the side ring.

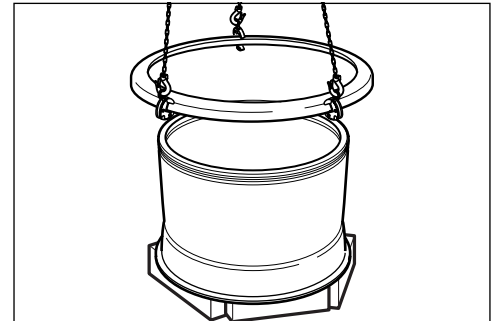

Warning

- Because this work involves handling heavy items, correctly use lifting equipment when necessary.
- When moving rim components, be careful to avoid accidental drops or falls that could injure you or others in the vicinity.

**STEP
5**

Install valve

- ① Install valve.



Warning

- For valve selection and installation, follow instructions in the manuals provided by your tyre dealer and valve manufacturer. If in doubt, contact the dealer or manufacturer for guidance.

8.4 How to mount tyre onto TOPY 5-piece rim

**STEP
6**

Confirm absence of tyre defects

- ① Confirm absence of tyre defects.



Warning

- Check with tyre dealer to confirm that there are no tyre defects. Using defective tyres could result in tyre failure while you are mounting the tyre and rim or during use, resulting in tyre separation and possible severe injury or death.

**STEP
7**

Mount tyre on rim base

- ① Apply a vegetable oil-based lubricant to both tyre bead seats.
- ② Place tyre on rim base, and assemble.

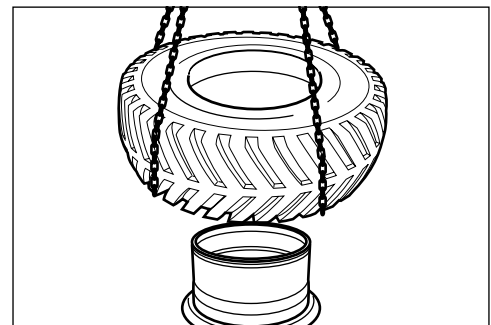

Notice

- **DO NOT** apply tyre lubricant to areas other than where the rim components come in contact with the tyre. Doing so could cause circumferential slippage between rim components when the vehicle is being driven.
- Consult your tyre dealer when selecting tyre lubricant.



Warning

- Because this work involves handling heavy items, correctly use lifting equipment when necessary.
- When moving rim components, be careful to avoid accidental drops or falls that could injure you or others in the vicinity.

8.4 How to mount tyre onto TOPY 5-piece rim

STEP 8 Fit side ring

① Fit the side ring.

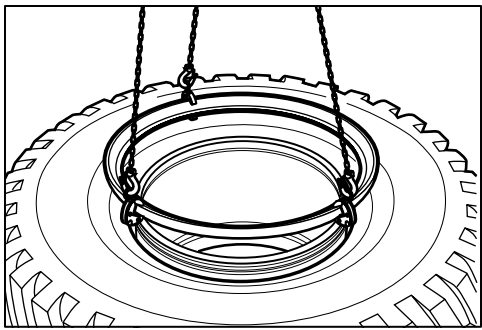

Warning

- Because this work involves handling heavy items, correctly use lifting equipment when necessary.
- When moving rim components, be careful to avoid accidental drops or falls that could injure you or others in the vicinity.

8.4 How to mount tyre onto TOPY 5-piece rim

**STEP
9**

Install bead seat band

- ① Insert bead seat band into side ring and rim base.
- ② Use the tyre lever to push in the bead seat band so that its edge fits with the tyre bead.

*Use in conjunction with auxiliary equipment (tyre handler, crane, press machine, etc.), when necessary.

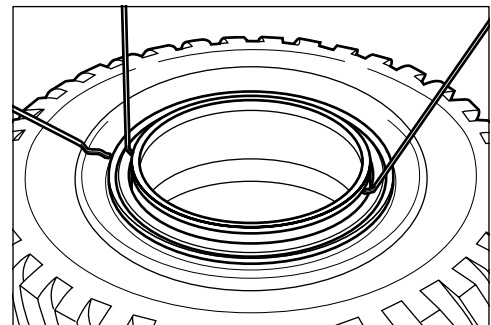
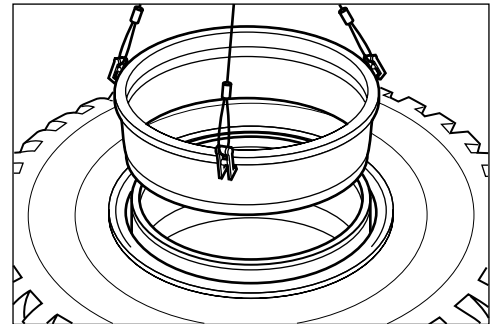

Warning

- Because this work involves handling heavy items, correctly use lifting equipment when necessary.
- When moving rim components, be careful to avoid accidental drops or falls that could injure you or others in the vicinity.
- If a mallet is used to aid in pressing down on the bead seat band, make sure you use soft metal or hard plastic hammer.
- **DO NOT** use a steel mallet.
- Insert the bead seat band carefully. Failure to keep the bead seat band horizontal during insertion will damage the inner surface.

8.4 How to mount tyre onto TOPY 5-piece rim

STEP 10 **Fit O-ring**

① Apply lubricant to new O-ring and install it in the O-ring groove.

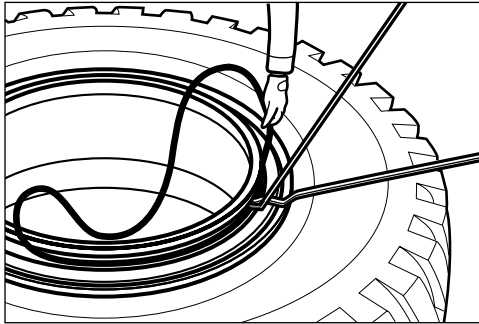

Caution

- Be careful not to get your fingers caught.

Notice

- Check with your tyre dealer for O-ring specifications or when selecting lubricant.
- Be careful not to twist the O-ring.

8.4 How to mount tyre onto TOPY 5-piece rim

**STEP
11**

Fit lock ring

- ① Place the ends of the lock ring into the lock ring groove in the rim base. Use the tyre lever to successfully install the lock ring around the entire circumference.
- ② Starting opposite the locking ring gap, lightly tap the locking ring with a soft metal or hard plastic hammer in both directions back to the locking ring gap to ensure the locking ring is clamped into the locking ring groove.

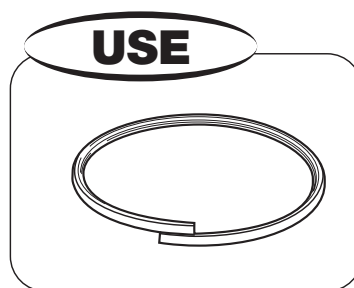
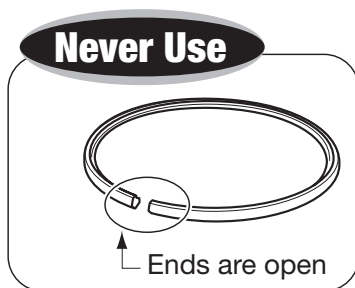
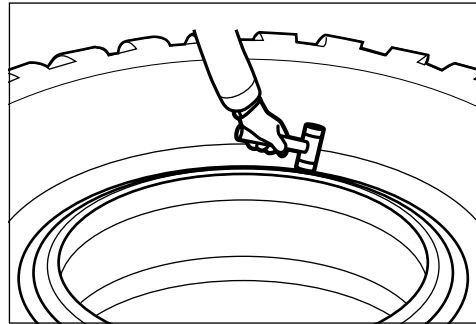
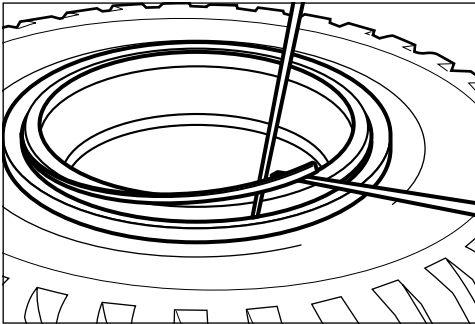

Warning

- **DO NOT** use lock rings with open ends (ends aren't touching).
- Check the facing of the lock ring. The lock ring is installed correctly if its markings are visible after tyre assembly.
- **DO NOT** use a steel mallet.



Caution

- Be careful when handling the lock ring as it may fly off.
- Be careful not to get your fingers caught.

8.4 How to mount tyre onto TOPY 5-piece rim

**STEP
12**

Install driver key

- ① For rims set with a driver key, install the driver key.

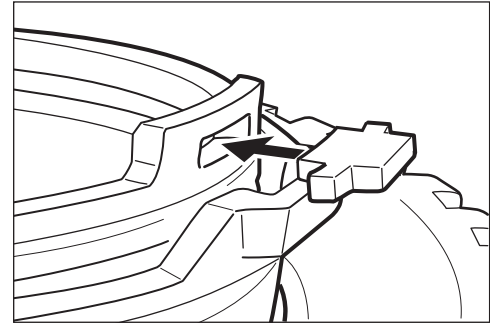

Caution

- Be careful not to get your fingers caught.

**STEP
13**

Confirm that rim components are assembled correctly

- ① Make sure that the combinations (matching), facings, and positions of rim components are correct.



Warning

- Recheck the tyre and rim component combinations (matching) and make sure they are correct.
- Recheck the facing of the lock ring and make sure it is installed correctly and is securely in the lock ring groove.
- **DO NOT** inflate, hammer, weld or solder to position the rim components. Doing so can lead to the deformation as well as the deterioration of the strength and structural integrity of the rim components.

8.4 How to mount tyre onto TOPY 5-piece rim

**STEP
14**

Inflating the tyre and rim

- ① Wherever possible, place the tyre and rim inside a tyre inflation safety cage, then inflate tyre. During inflation, keep away from the tyre.
- ② When tyre has been inflated to a pressure of approximately 35kPa (5psi), check assembly of tyre and rim components.
- ③ If assembled correctly, continue inflating up to the rated value.

Tyre inflation safety cage

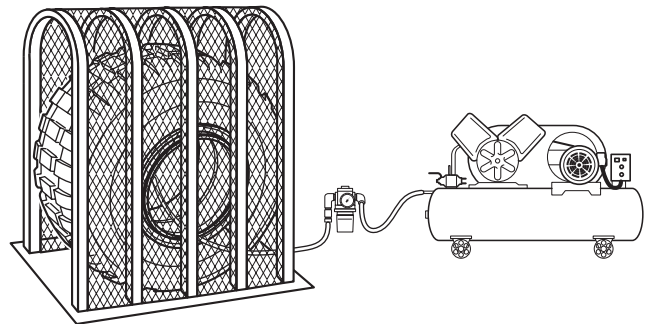

Warning

If assembly has been done incorrectly, inflation could result in an explosive separation of the rim. This separation could result in serious injury or death to you or bystanders. Workers and persons responsible for supervising the work must comply strictly with the following warnings.

- Wherever possible, ensure that the work is carried out with the tyre inside a tyre inflation safety cage.
- While inflating, workers and bystanders must always be outside the range of the "hazardous trajectory". Exercise extreme caution as the trajectory may widen.
- During inflation, use an air pressure gauge and regulator valve.
- To ensure that the worker inflating the tyre can remain outside of the "hazardous trajectory", use an air pressure gauge and a hose of adequate length, and use an air chuck.
- During inflation, **DO NOT** allow the air pressure to exceed the pressure recommended by your tyre manufacturer.
- If you notice a mistake in the assembly, immediately stop inflation, release the air, and reassemble the tyre and rim components.
- **NEVER** attempt to position the rim components by inflating the tyre.
- Because this work involves handling heavy items, correctly use lifting equipment when necessary.
- When moving rim components, be careful to avoid accidental drops or falls that could injure you or others in the vicinity.
- Lay the assembled and inflated tyre rim so it is flat and stable and not subject to impacts.

Notice

In order to prevent corrosion of the rim components, inflate tyres with dry air.

8.5 Checkpoint of servicing tyres and rims when rim remains installed on vehicle

If servicing tyre and rim when the rim remains installed on the vehicle, be sure to comply strictly with the following points.

**POINT
1**

Release all air from the tyre

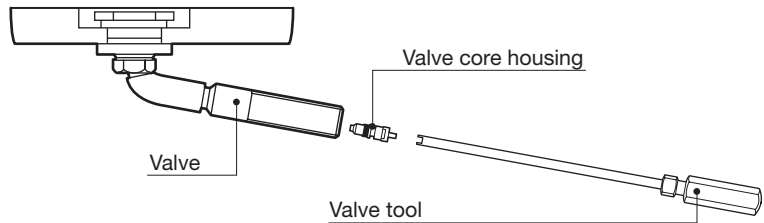
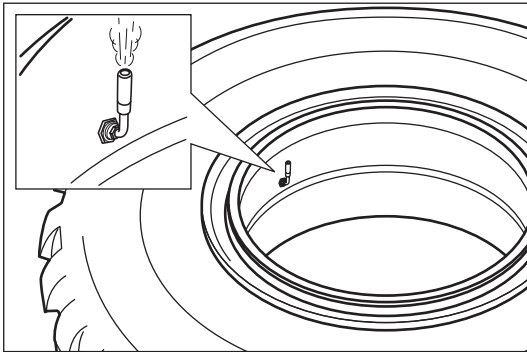

Warning

- Ensure that the power is off and vehicle is blocked so it can't move.
- When jacking up the vehicle during tyre and rim servicing work, carefully read the vehicle manufacturer's instruction manual and make sure that all protective measures are in place to prevent the vehicle or jack from moving.
- Remove the valve core and release all air from the tyre.
- Be aware of the trajectory of the valve core as it may shoot out during its removal.
- If there is any foreign matter inside the valve, the air will not be released. Insert wire, etc. into the valve to clear away foreign matter.
- Before removing rim base accessories (extension valve fixing brackets, etc.), remove all air from the tyre.
- When removing the outer tyre and rim of dual assemblies, also fully release the air from the inner tyre.
- Tyres should be deflated outside the range of the "hazardous trajectory" shown by the arrow in the diagram below. Exercise extreme caution as the range of the trajectory may widen.
- During deflation work, **DO NOT** allow other workers or third parties to approach the area of the trajectory.
- When releasing air, stand in a safe location as foreign matter or frozen particles inside type might be discharged.
- Do not allow high pressure air stream to hit skin.

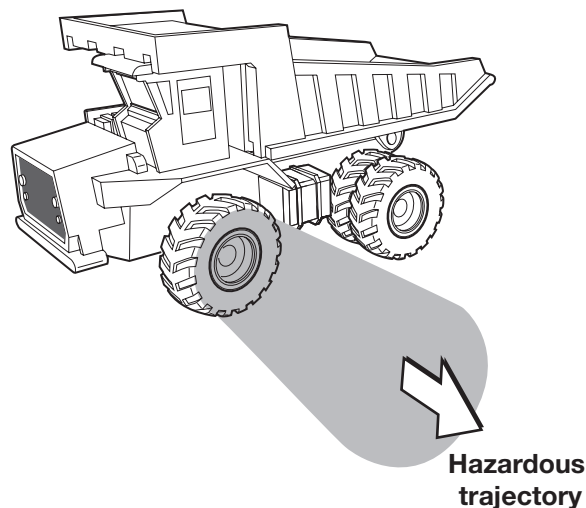

8.5 Checkpoint of servicing tyres and rims when rim remains installed on vehicle

**POINT
2**

Mount bead breaker securely



Warning

- When the bead breaker is to be pressed against part of the vehicle, follow the instructions and manual published by the vehicle manufacturer for the pressing location, and mount the bead breaker as instructed. Damage to vehicle components and the bead breaker falling due to coming loose can be extremely dangerous.

**POINT
3**

Protection against explosive separation of tyre and rim components



Warning

- Always work outside the range of the “hazardous trajectory” shown in the diagram below. Exercise extreme caution as the range of the trajectory may widen.
- During work, **DO NOT** allow other workers or third parties to approach the area near the hazardous trajectory.
- “Explosive separation of the rim” could cause severe injury, not just to workers but also to bystanders in the vicinity.
- When servicing tyres still on the vehicle, take protective measures against the hazardous trajectory, such as using the crane arm or tyre handler.

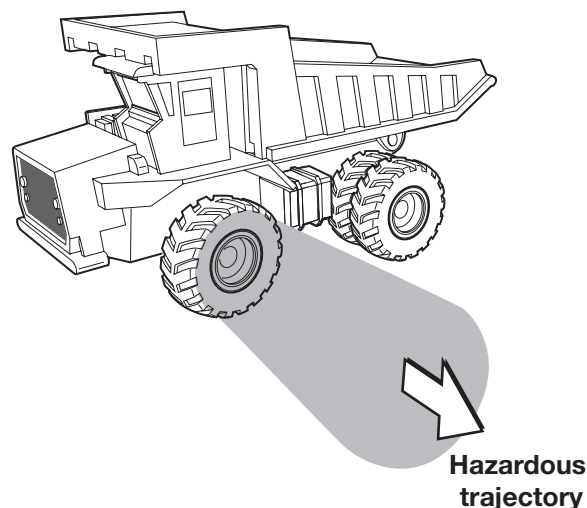

9. Maintenance

Comply with the warnings and precautions given here, in order to fully utilize the performance of tyres and rims when used with industrial and construction vehicles, and to prevent accidents during maintenance, servicing, and operation.



Warning

- Maintenance work should be carried out only by workers who have received adequate training from a qualified supervisor on safe handling of tyres and rims.
- During maintenance work, **DO NOT** allow other workers or third parties to approach the area near the hazardous trajectory.
- Check the “Tyre and Rim Handling Manual” published by the tyre manufacturer for information on work and inspections, etc. involving tyre handling.
- Be sure you have a proper understanding of how the tools are used and carry out the work in accordance with the proper procedure.
- Ensure that protective equipment is worn during maintenance work. (Wear gloves, safety shoes, safety glasses, face protection, earplugs, hard hat, etc.)
- Refer to “8. Procedures for tyre and rim servicing” of this manual for performing servicing and maintenance work on tyres and rims.
- When performing maintenance with the tyre and rim installed on a vehicle, ensure that the power is off and vehicle is blocked so it can't move during maintenance.
- When jacking up the vehicle during tyre and rim servicing work, etc., carefully read the vehicle manufacturer's instruction manual and make sure that all protective measures are in place to prevent the vehicle or jack from moving.
- Record rim maintenance history because it is a vital reference in safe application.

9.1 Regular inspection checkpoints

The following is an explanation of regular inspections performed with the tyre mounted on the rim.



Warning

- During tyre inspections, check that there is no cracking, wear, or deformation etc. on the rim components. Conduct a thorough inspection of the gutter section and back flange section, indicated by the red circle in the diagram below. The diagram below also shows check points for "9.2 inspections when servicing tyres and rims".
- Conduct daily inspections in order to maintain the performance and the safety of tyres and rims.
- When servicing tyres, make sure that inspections are performed in accordance with "9.2 Inspections when servicing tyres and rims".

Notice

Before starting maintenance work, it is recommended that tyre pressure records are updated to ensure early detection of air leaks which may be caused by cracks in rim components.

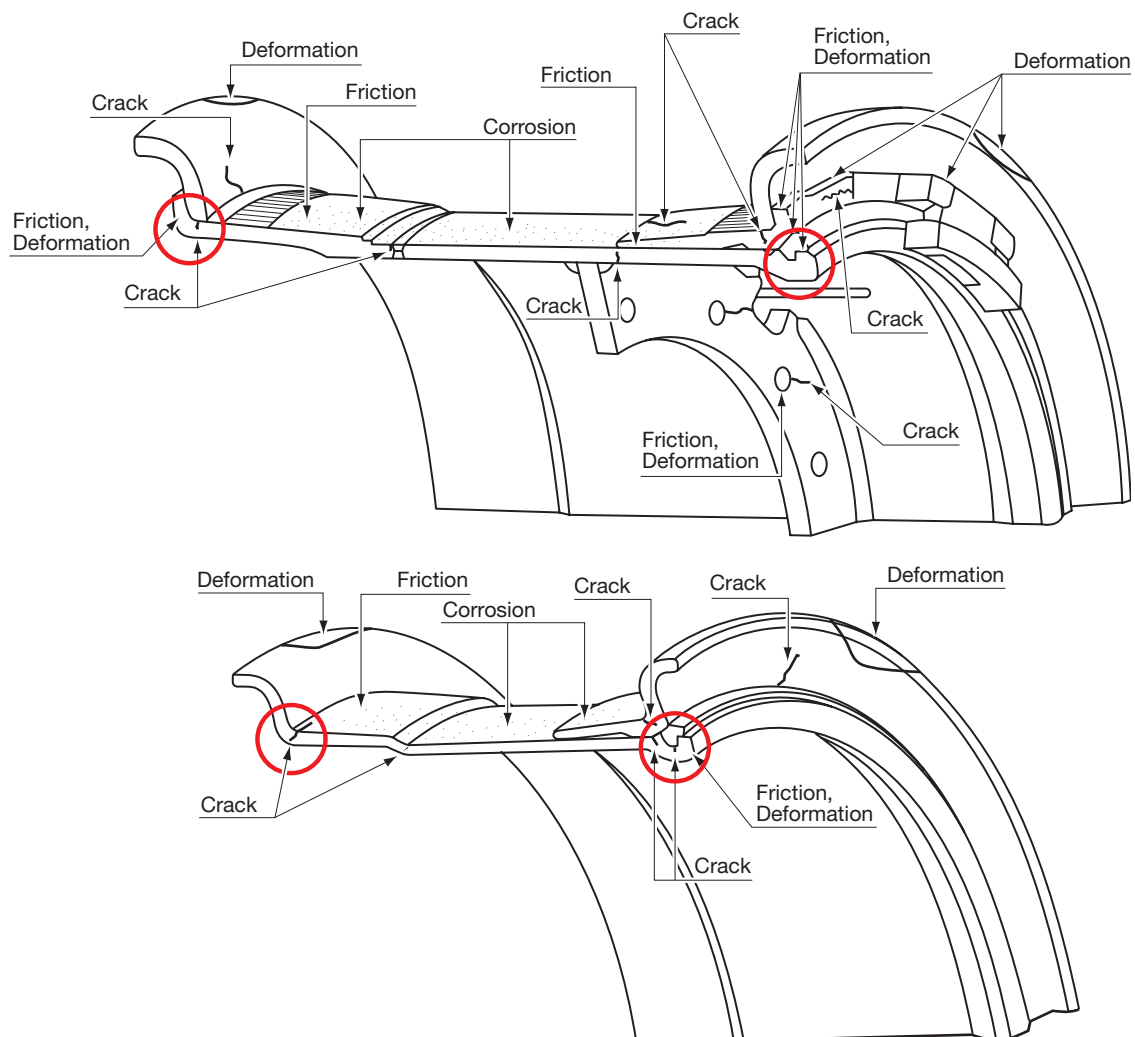

9.2 Inspections when servicing tyres and rims

9.2.1 Ensuring safety when servicing tyres and rims



Warning

- For safety precautions that should be followed when servicing tyres and rims, comply with “8. Procedures for servicing tyres and TOPY rims”.

9.2.2 Cleaning prior to inspection

Cleaning rim components using a wire brush makes examination and tyre installation easier. Pay particular attention to cleaning the O-ring grooves and lock ring grooves on the gutter.

9.2 inspections when servicing tyres and rims

9.2.3 Inspection

Perform inspections based on the check methods and checkpoints presented in the tables that follow.



Warning

- Perform inspections based on the check methods and checkpoints in the tables below.
- For tyre inspections, check the “Tyre and Rim Handling Manual”, published by the tyre manufacturer.

Rim base inspections

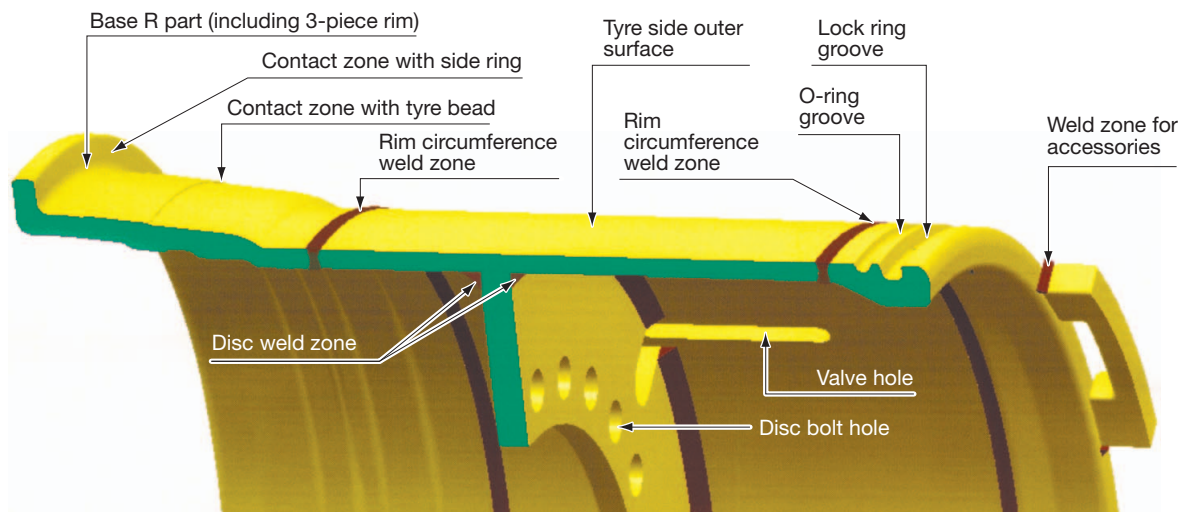

Inspected part	Check method	Checkpoint				
		Cracking	Wear	Deformation/ Ellipse	Corrosion	Surface roughness
O-ring groove	Visual inspection	○			○	○
	Non-destructive inspection	○				
Lock ring groove	Visual inspection	○	○		○	○
	Non-destructive inspection	○				
Contact zone with side ring	Visual inspection	○	○		○	○
	Non-destructive inspection	○				
Base R part	Visual inspection	○	○		○	○
	Non-destructive inspection	○				
Rim circumference weld zone	Visual inspection	○				
	Non-destructive inspection	○				
Valve hole	Visual inspection	○			○	
	Non-destructive inspection					
Disc weld zone	Visual inspection	○				
	Non-destructive inspection	○				
Disc bolt holes	Visual inspection	○	○	○		
	Non-destructive inspection					
Contact zone with tyre bead	Visual inspection		○		○	
	Non-destructive inspection					
Tyre side outer surface	Visual inspection				○	
	Non-destructive inspection					
Weld zone for accessories	Visual inspection	○				
	Non-destructive inspection					

Note: Non-destructive inspections include magnetic particle inspections, ultrasonic inspections, and dye penetrant inspections, etc.

* Always verify the actual product for the weld zones of rim components as they vary by type.

9.2 Inspections when servicing tyres and rims

Lock ring inspections

For 3-piece rims

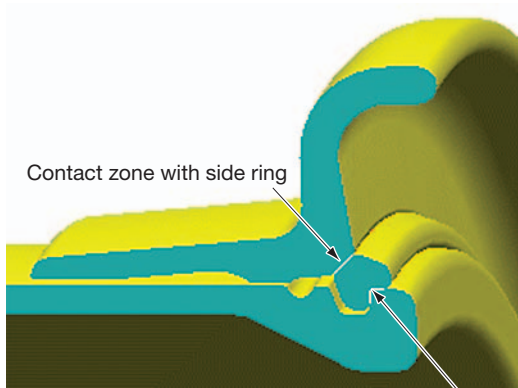

Contact zone with gutter section

For 5-piece rims



Contact zone with gutter section

Inspected part	Check method	Checkpoint				
		Cracking	Wear	Deformation/ Ellipse/ Spread Edges	Corrosion	Surface roughness
Contact zone with bead seat band or side ring	Visual inspection	○	○			○
	Non-destructive inspection					
Contact zone with gutter of rim base	Visual inspection	○	○		○	○
	Non-destructive inspection					
Overall form	Visual inspection			○		
	Non-destructive inspection					

Note: Non-destructive inspections include magnetic particle inspections, ultrasonic inspections, and dye penetrant inspections, etc.

9.2 Inspections when servicing tyres and rims

Bead seat band inspections

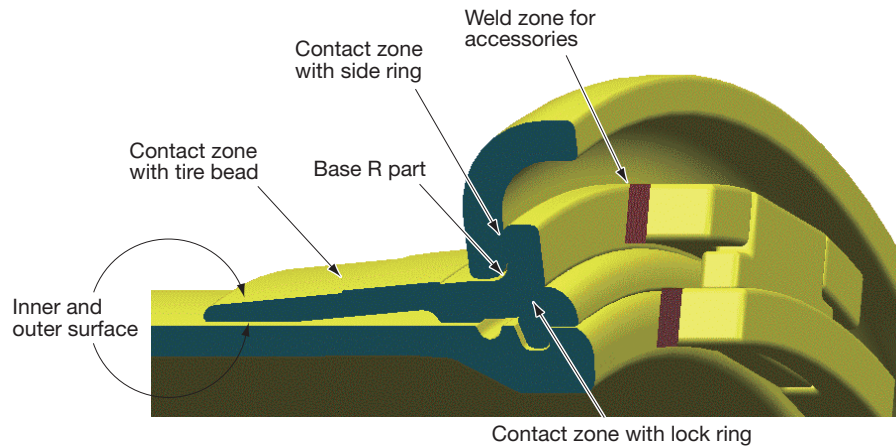

Inspected part	Check method	Checkpoint				
		Cracking	Wear	Deformation/ Ellipse	Corrosion	Surface roughness
Base R part	Visual inspection	○	○		○	○
	Non-destructive inspection	○				
Contact zone with side ring	Visual inspection	○	○		○	○
	Non-destructive inspection	○				
Contact zone with lock ring	Visual inspection	○	○			○
	Non-destructive inspection					
Contact zone with tyre bead	Visual inspection		○		○	
	Non-destructive inspection					
Inner and outer surface	Visual inspection				○	
	Non-destructive inspection					
Overall form	Visual inspection			○		
	Non-destructive inspection					
Weld zone for accessories	Visual inspection	○				
	Non-destructive inspection					

Note: Non-destructive inspections include magnetic particle inspections, ultrasonic inspections, and dye penetrant inspections, etc.

* Always verify the actual product for the weld zones of rim components and accessories as they vary by type.

9.2 Inspections when servicing tyre and rims

Side ring inspections

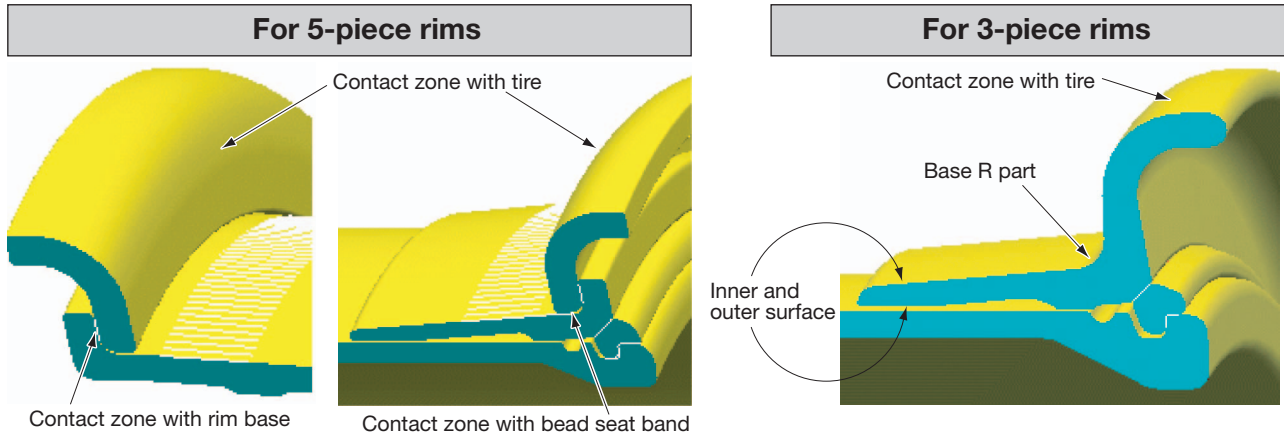

Inspected part	Check method	Checkpoint				
		Cracking	Wear	Deformation/ Ellipse	Corrosion	Surface roughness
Contact zone with rim base (for 5-piece rims)	Visual inspection	○	○			○
	Non-destructive inspection	○				
Contact zone with bead seat band (for 5-piece rims)	Visual inspection	○	○			○
	Non-destructive inspection	○				
Base R part (for 3-piece rims)	Visual inspection	○	○		○	○
	Non-destructive inspection	○				
Inner and outer surface (for 3-piece rims)	Visual inspection				○	
	Non-destructive inspection					
Contact zone with tyre	Visual inspection		○		○	
	Non-destructive inspection					
Overall form	Visual inspection			○		
	Non-destructive inspection					

Note: Non-destructive inspections include magnetic particle inspections, ultrasonic inspections, and dye penetrant inspections, etc.

9.3 Action as a result of inspection

9.3 After inspection

If any problems are found as a result of inspection, take appropriate measures to correct them.



Warning

- Any rim components with cracks or wear/damage/deformation/corrosion judged to be unusable, should be clearly labeled to indicate their condition and disposed.
- Lock rings with open ends (ends aren't touching) will not set correctly. Clearly label such rings to indicate they are unusable and dispose them.
- For installation and removal of rim drivers, valve guards, etc. or to perform other repairs, obtain approval from your TOPY rim dealer and be sure to remove the tyre before carrying out any work.



Caution

- Recoat parts where anti-corrosive oil or paint is peeling off.
- Anti-corrosive oil and paint may contain toxic ingredients. Follow the instructions provided by the manufacturers of the anti-corrosive oil or paint.



TOPY INDUSTRIES, LIMITED

**WHEEL DIVISION, GENERAL SALES DEPT.
CONSTRUCTION & INDUSTRIAL EQUIPMENT
WHEEL SALES DEPT.**

2-3-1 Ogami, Ayase, Kanagawa 252-1104

Phone: 0467(78)9611 Fax: 0467(78)9609

E-mail: rims@topy.co.jp

TOPY AMERICA, INC.

OTR DIVISION

1200 Mark Street, Elk Grove Village, IL 60007 U.S.A.

Phone: 1-847-439-4420 Fax: 1-847-439-4476

E-mail: sales@topywheels.com

WESTERN SALES OFFICE

1096 N. Redwood Rd. North Salt Lake, UT 84054 U.S.A.

Phone: 1-801-292-6620 Fax: 1-801-292-7189

E-mail: sales@topywheels.com