



# *USER INSTRUCTIONS*

## *Automax CENTURA™ CE Series*

Electric Rotary Valve Actuator

FCD AXENIM0037-01 – 10/05 (Replaces AUTO-37)

*Installation*  
*Operation*  
*Maintenance*



*Experience In Motion*

## Introduction

The Centura electric actuator is a rotary valve actuator with output torques from 250 to 1,500 in-lbs. It has been designed for NEMA 4, 4X, 7, 9 and can come with a 4-20 mA card for modulating service.

## Storage

For short and long term storage refer to short and long term storage conditions CE Actuator.

## Maintenance

Centura Series actuators contain a permanently lubricated, precision cut, heat treated gear train for long, reliable cycle life. There is no need to change gear train grease; however, should it become necessary to refill, use a multi-purpose grease such as DuBois MPG-2.

Permanent split capacitor gearmotors have been equipped with thermal protectors. After many operations, especially in warm environments, the motor will heat up. To guard the motor against overheating, the thermal cut-out blocks power to the motor and maintains this state until the motor's temperature drops to a satisfactory level. This thermal protection means that the actuator will not move when overheated. Consideration must be given to the duty cycle requirements of the actuator.

When replacing the cover, the machined joints must be clean and clear of any obstructions. The integrity of the explosion-proof rating depends on the care of these joints.

## Installation

1. This section of the instruction sheet applies to the on-off units. For instructions on Modulating units, please see the ESP3 Electronic Servo Positioner Instructions.
2. Manually open and close valve to ensure freeness of operation.

**▲ CAUTION:** To prevent ignition of hazardous atmospheres, keep unit tight while circuits are alive. Disconnect supply circuit before opening.

3. Be sure valve and Automax actuator rotate in the same direction and are in the same position (i.e., valve closed, actuator closed). If not sure, electrically operate the actuator to determine its operating range, taking note of any explosion safety requirement. The electric actuators are factory set for 90 degree operation.

**▲ CAUTION:** Use heavy duty brake option 'K' for rubber lined butterfly valves & dampers or applications that may back drive the unit.

4. Mount Automax actuator to valve with Automax provided mounting hardware to ensure proper alignment. Use mounting hardware that has 1½ times bolt length engagement. (Do not use the manual override to align actuator shaft to valve shaft, as this could drive the actuator out of its operating range).

**NOTE:** Some valves have manual stops; remove if appropriate or set actuator to operate within those travel stops).

5. Care should be taken to align valve stem properly with Automax actuator output shaft (misalignment will cause premature failure of assembly).
6. To connect power to terminal strip of actuator, remove the cover and locate the terminal wiring schematic inside the cover.
7. Connect power to terminal strip according to schematic diagram (power should be fused with a 5 amp slow-blow fuse). The actuator should be wired and grounded in accordance with Local and National Electrical Codes.

**▲ CAUTION:** Consult factory when wiring multiple actuators in series or parallel. Serious damage may result. User must isolate unused winding.

8. Before replacing cover, actuate valve and check to see if it opens and closes to preferred positions. If valve does not perform correctly, adjust cams to set actuator travel properly.
9. Drive actuator to desired open position. The cams are adjusted in two ways. Simply depress the splined "Quick-Set" cam against the spring and rotate to desired location. Or, for very precise applications, turn the screw inside the cam to move the tip into the leaf of the micro switch.
10. To adjust closed position, repeat step 9 with actuator in desired closed position.
11. Operate the unit several times and recheck position. If unit is still out of adjustment, reset the cams by following steps 9 and 10.
12. Installation in hazardous areas requires that the electrical leads be sealed within 18 inches of the enclosure in accordance with Local and National Electrical Codes.
13. Open conduit entries must be closed up after installation is complete using a close-up plug engaging at least five full threads and approved for use in hazardous locations.

- 60Hz actuator motors may be run on 50 Hz supply. However, the cycle time increases by 1.2 times and the duty cycle decreases by a factor of approximately 25%. The rated torque does not change.

## Manual Override

The principle of the design is such that when the manual override shaft is in the up position, the shaft is disconnected from the drive train. When the shaft is in the down position it does two things. One, the shaft trips a switch to disconnect the power to the motor and two, it releases the brake. By releasing the brake the motor can back drive along with the output. For 90 degree operation, the 250 in-lbs unit requires 1.6; the 700 in-lbs unit requires 3.1; the 1000 in-lbs unit requires 4.2; and 1500 in-lbs unit requires 6.3.

**⚠ CAUTION:** Turn manual override shaft slowly. DO NOT jerk.

## Manual Operation

- The actuator cover should be securely attached.
- Depress hub toward actuator cover.
- Rotate the manual override shaft slowly; do not force.
- The motor is now electrically disconnected.
- Turn the manual override shaft clockwise for clockwise output.
- Do not rotate actuator past full clockwise or counter-clockwise position.

## Automatic Operation

- Pull hub away from the actuator cover.
- The motor is now electrically connected and ready for automatic operation.
- The manual override shaft will freewheel.

## Position Indication Stickers

Attached to the inside of the cover is a set of stickers with the words "CLOSED" and "OPEN". These stickers are to be attached to the outside of the actuator near the base between the mounting feet. The stickers have an orange triangle on them, such that when properly attached to the actuator, they will line up with the triangle on the output shaft. A sticker can be placed on either side of the unit to produce a visual indication of the opened and closed position of the actuator.

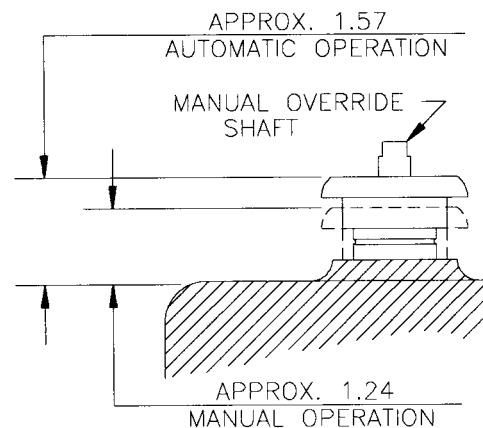
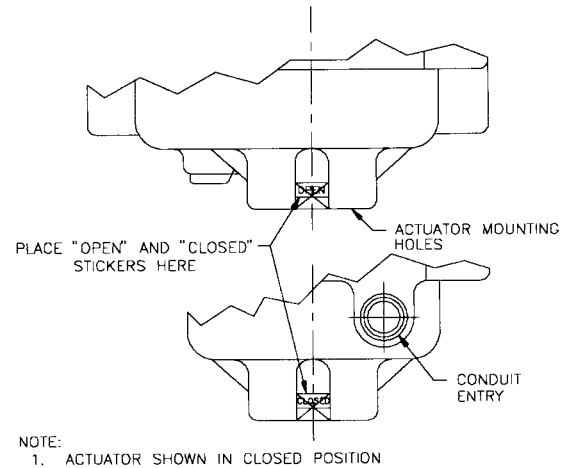

Common Parts Related to All Actuators

No.	Item	Material	P/N	Qty
1	Painted Cover	Cast Aluminum	106100	1
2	5/16-24UNF HHCS/Shank	Stainless Steel	103233	8
3	5/16 Type A Washer	Stainless Steel	103715	8
4	1/2" Sleeve Bearing	Sintered Bronze	105590	1
5	Molded Oil Seal	Nitrile	105585	1
6	Manual Override Hub	Black 141 Lexan	105567	1
7	7/16 I.D. Klipring	Stainless Steel	106174	1
8	Handwheel (Optional)	Black Plastic	105974	1
9	Manual Override Shaft	Steel/Plated	105591	1
10	Brake Trip Washer	Aluminum	107065	1
11	Manual Override Coupler	Steel/Plated	106129	1
	Manual Override Spring	Spring Steel	105593	1
	1/16 Dia. Roll Pin	Spring Steel	103621	1
12	O-Ring, Base	N674-70 Nitrile	105584	1
13	CE1/CE2 Machined Base	Cast Aluminum	106098	1
	CE4/CE7 Machined Base	Cast Aluminum	106099	1
	CE5 Machined Base	Cast Aluminum	107503	1
14	3/8" Needle Bearing	Steel/Plated	105582	1
15	3/8" Sleeve Bearing	Sintered Bronze	105581	4
16	O-Ring, Output Shaft	N674-70 Nitrile	105583	1
17	1 1/2" Sleeve Bearing	Sintered Bronze	409944	1
18	CE1/CE2 Motor Plate	Cast Aluminum	106080	1
	CE4/CE7 Motor Plate	Cast Aluminum	106081	1
	CE5 Motor Plate	Cast Aluminum	107504	1
19	3/8" Sleeve Bearing	Sintered Bronze	105694	1
20	8-32 UNC Ground Screw	Steel/Plated	103627	1
21	#8 Cup Washer	Brass	105626	1
22	8-32 UNC x 5/8" Hex Screw	Steel/Plated	105577	5
23	8-32 UNC x 5/8" Phillips Hd.	Steel/Plated	105576	1
24	Actuator Bracket	Steel/Plated	108099	1
27	M.O. Cut-off Switch	Plastic/Steel	105769	1
28	Switch Insulator Gasket	Vulcanized Fiber	103675	5
29	4-40 UNC x 5/8" Phillips Hd.S	Steel/Plated	106146	2
30	4-40 UNC x 1 1/4" Phillips Hd.	Steel/Plated	100159	2
31	3/16" Higher Spacer	Nylon	105679	2
32	15 Amp Switch	Plastic/Steel	107765	2
33	3/16" Pop-in Bearing	Plastic	105851	1
34	Camshaft	Steel/Plated	107005	1
35	Large 4-Deg. Spline Shaft	Plastic	103571	1
	1/16" Dia. Roll Pin	Spring Steel	103621	1
36	Small 4-Deg. Spline Shaft	Plastic	103572	1
	1/16" Dia. Roll Pin	Spring Steel	103621	1
37	Switch Spring	Spring Steel	103714	1
38	Hi-Ramp Cam	Plastic	107322	2

Continued on Page 5

Common Parts Related to All Actuators (continued from Page 4)

No.	Item	Material	P/N	Qty
39	CE2/CE4 Output Shaft Ass'y	Steel	106096	1
	CE5 Output Shaft Ass'y	Steel	107700	1
	CE1/CE7 Output Shaft Ass'y	Steel	106097	1
40	CE1/2/5/& 7 Offset Shaft	Steel 86L20	104864	1
	1/8 x 1/8 x 1.19" Long Key	Steel	105589	1
41	CE1 Offset Pinion	Steel -Heat Treated	104893	1
	CE2 Offset Pinion	Steel -Heat Treated	104887	1
	CE4 Offset Pinion	Steel -Heat Treated	104889	1
	CE7 Offset Pinion	Steel -Heat Treated	104891	1
	CE5 Offset Pinion	Steel -Heat Treated	107169	1
42	CE1/CE7 Offset Gear	Steel -Heat Treated	104890	1
	CE2 Offset Gear	Steel -Heat Treated	104885	1
	CE4 Offset Gear	Steel -Heat Treated	104884	1
	CE5 Offset Gear	Steel -Heat Treated	107168	1
43	1.00 O.D.x 0.031 Spacer	Steel	105587	1
44	3/16" I.D. Snap Ring	Spring Steel	100678	2
58	Nameplate	Stainless Steel	105578	1
	Ty-Rap Cable Tie	Plastic	101066	2
	3/32" Dia. Drive Pins	Stainless Steel	105454	2
	Cam Adjustment Sticker	Mylar	105757	1
	Manual Override Sticker	Mylar	105756	1
	Automax Logo Sticker	Mylar	105862	2
	Position Indication Sticker	Mylar	106187	1
	3/4" NPT Conduit Plug	Plastic	103685	1
	Open/Close Stickers	Mylar	106186	1
59	Press Fit Washer	Steel	107178	1
60	Plug	Steel/Plated	107126	2

Additional Parts Specific To 115 VAC Actuators CE2, CE4, CE7, CE1, CE5

No.	Item	Material	P/N	Qty
49	115 VAC PSC Motor Int.	Steel/Copper	105675	1
	16 Fin Impeller Fan	Plastic	105703	1
	10-32 UNC x 3/16" SHCS	Steel/Plated	105599	2
54	Capacitor	Plastic Encapsulated	106619	1
55	Wire Tie	Plastic	106243	2
56	Quick Connect	Plastic/Steel	106761	4
25	6 Position Terminal Strip	Plastic/Steel	103997	1
	2 Screw Marker Strip	Plastic	103996	1
26	3-48 UNC x 1/2" Pan Head	Steel/Plated	104837	2
	115 VAC Wire Harness	Copper/Plastic	106111	1
	115 VAC Schematic Sticker	Gloss Paper	815169	1

NOTE:  
 1) ACTUATOR IS SHOWN IN THE FULL CLOCKWISE POSITION AS VIEWED FROM THE MOTOR SIDE.  
 2) ACTUATOR IS DESIGNED FOR NEMA 4, 4X, 7, AND 9 RATINGS.  
 3) OUTPUT TORQUES: 250, 400, 700, 1000, 1500 IN.-LBS.

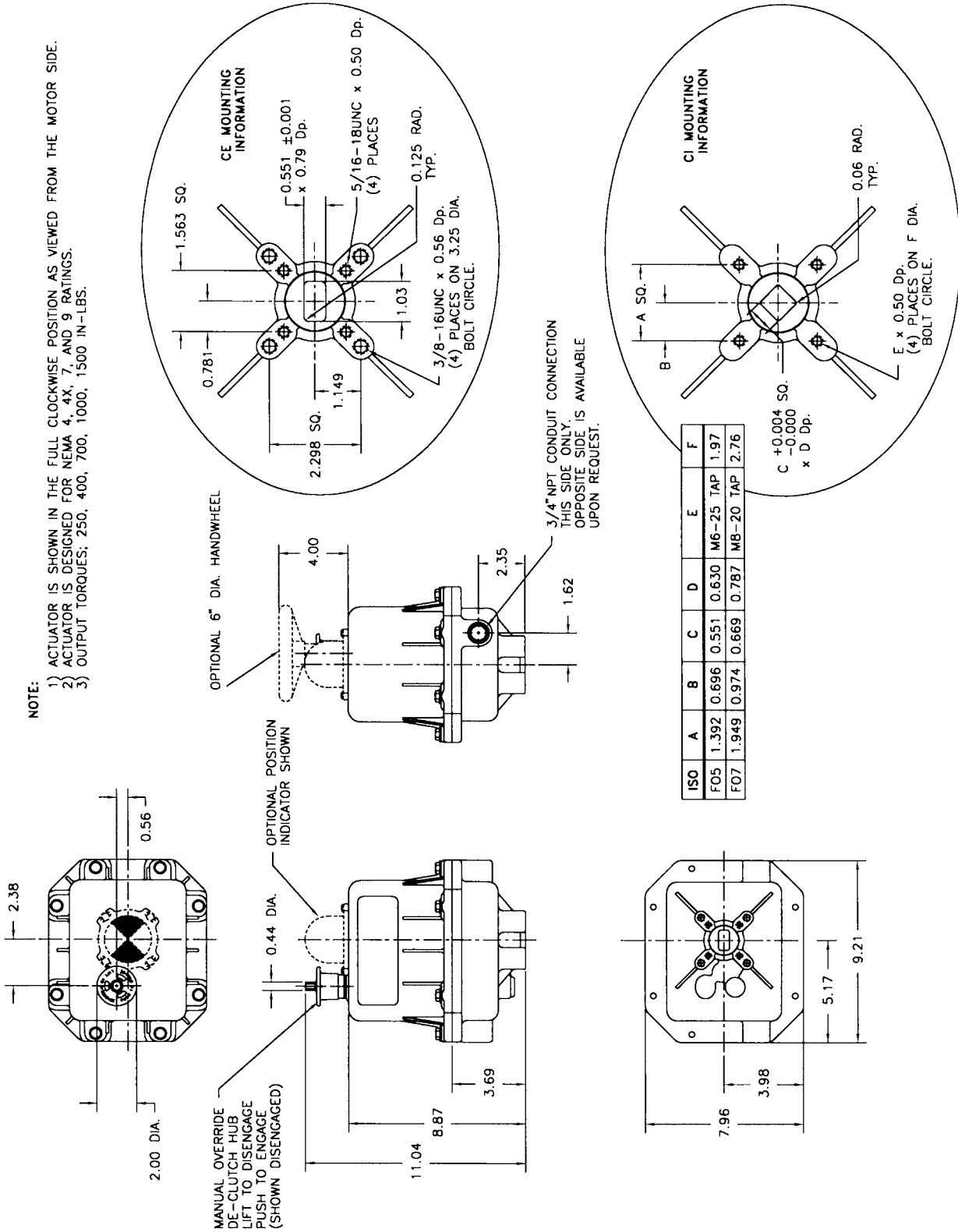

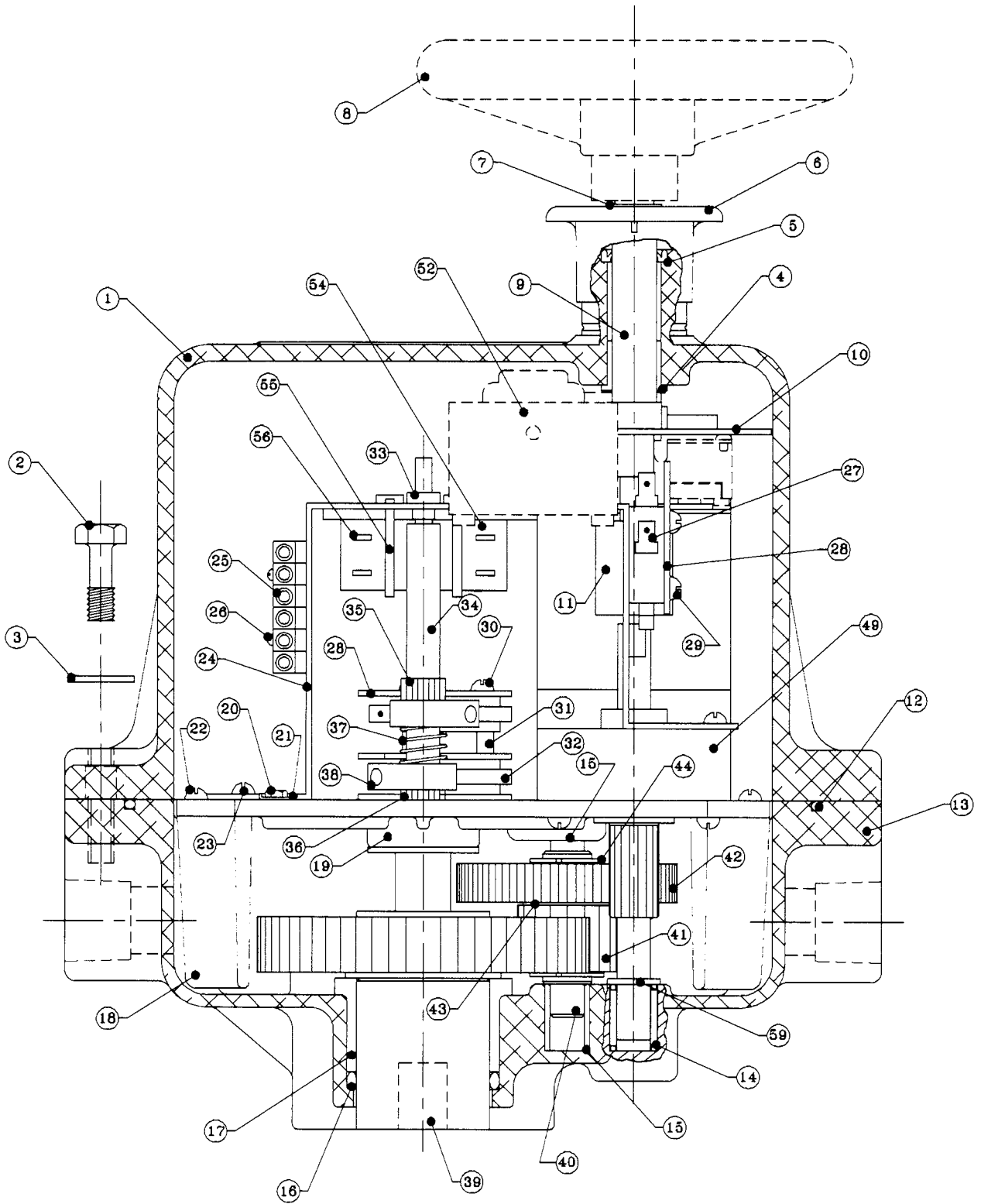

*Additional Parts Specific To 115 VAC With ESP Servo Positioner Actuators CE2ATA, CE4ATA, CE7ATA, CE1ATA, CE5ATA*

No.	Item	Material	P/N	Qty
49	115 VAC PSC Motor Ext.	Steel/Copper	105676	1
	Fan Hub	Pressed Metal	107939	1
	Fan	Plastic	107940	1
	Compression Spring	Steel	108431	1
	Brake Hinge Ass'y	Steel/Plastic	108600	1
52	Brake Solenoid	Coil	108022	1
	Switch Spring	Steel	103714	1
	Wave Spring	Steel	108198	1
	10-32UNF Set Screw	Stainless Steel	103486	1
	.75 x .459 x .042 Washer	Brass	108361	1
	Klip Ring	Stainless Steel	106174	1
	6-32 x ½ Phil. Screw	Steel	106061	1
	.350 x .118 Lg. Spacer	Bronze	108296	2
	6-32 Hex. Nut	Nylon/Steel	105864	1
	10-32UNF SHCS	Steel	105599	2
	#6 Type A Plain Washer	Steel	100986	3
	Brake Shim	Steel	108199	1
	8-32 x ⅝ Phil. Screw	Steel	105576	3
55	Wire Tie	Plastic	106243	2
56	Quick Connect	Plastic/Steel	106761	4
54	Capacitor	Plastic Encapsulated	106618	1
	#6 x 0.19 lg. Spacer	Aluminum	100839	1
	6-32 UNC x ⅜" Phillips Hd.	Steel/Plated	100881	1
	¼ Turn Standoff	Plastic	105168	2
	ESP3 Servo Positoner	Fiberglass	105005	1
	Potentiometer	Plastic	106195	1
	85- Tooth Gear	Aluminum	107312	1
	85- Tooth Gear	Aluminum	105853	1
26	115 VAC ESP3 Wire Harness	Copper/Plastic	106194	1
	ESP3 Schematic Sticker	Glass Paper	815224	1

*Additional Parts Specific To 12 VDC Actuators CE2B, CE4B, CE7B, CE1B, CE5B*

No.	Item	Material	P/N	Qty
49	12 VDC Gearmotor	Steel/Copper	106088	1
	Motor Bracket Spacer	Aluminum	106193	2
25	6 Piston Terminal Strip	Plastic/Steel	103997	1
	2 Screw Marker Strip	Plastic	103996	1
26	3-48 UNC x ½" Pan Head	Steel/Plated	104837	2
	12 VDC Wiring Harness	Copper/Plastic	106196	1
	12 VDC Schematic Sticker	Gloss Paper	815176	1

*Additional Parts Specific To 24 VDC Actuators CE2C, CE4C, CE7C, CE1C, CE5C*

No.	Item	Material	P/N	Qty
49	24 VDC Gearmotor	Steel/Copper	106088	1
	Motor Bracket Spacer	Aluminum	106193	2
25	6 Position Terminal Strip	Plastic/Steel	103997	1
	2 Screw Marker Strip	Plastic	103996	1
26	3-48 UNC x ½" Pan Head	Steel/Plated	104837	2
	24 VDC Wiring Harness	Copper/Plastic	106197	1
	24 VDC Schematic Sticker	Gloss Paper	815176	1



# Wiring Diagrams

**⚠ CAUTION:** To prevent ignition of hazardous atmospheres, keep unit tight while circuits are alive. Disconnect supply circuit before opening.

**⚠ CAUTION:** Consult factory when wiring multiple actuators in series or parallel. Serious damage may result.

**NOTE:** Wiring diagrams show internal wire connections and suggested customer connection for proper use. Switches shown in “customer wiring” are for illustration only and are not supplied with the actuator.

## Reversible DC Actuator

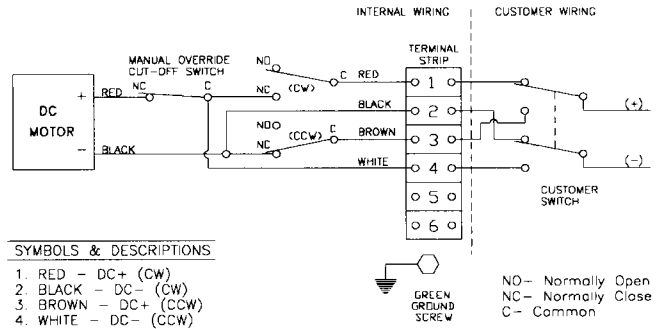

## Reversible AC Actuator

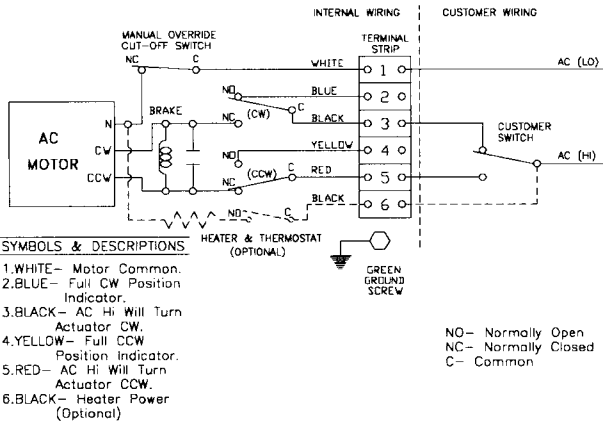

## Reversible AC Actuator with 2 Extra Switches

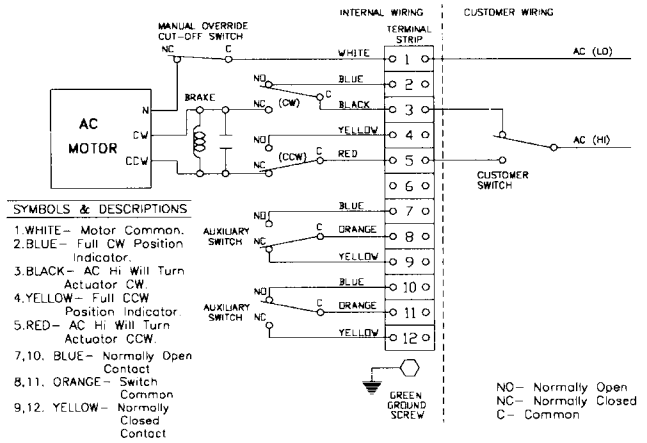

## Reversible Modulating AC Actuator

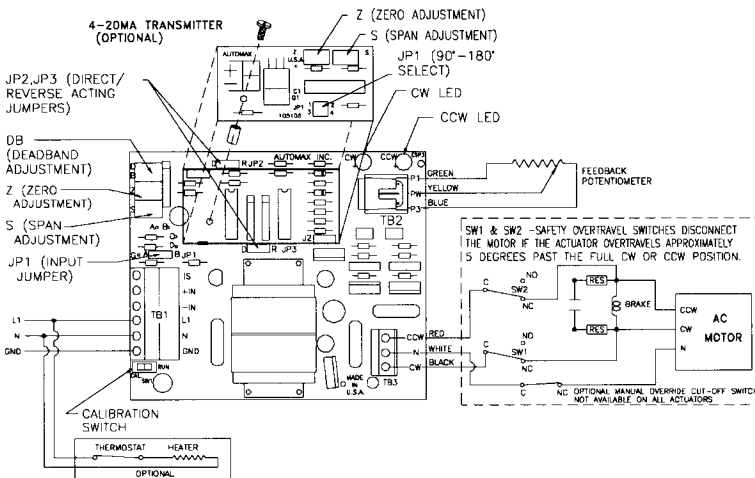

## Typical Actuator Specifications

Action	Reversible	
Range of Adjustability	0° -270°	
Supply Voltages	AC:	115 VAC
	+/-10%	230 VAC
	50/60 Hz	24 VAC
	DC:	12 VDC
		24 VDC
Temperature Rating	-40°F (-40°C) to 160°F (70°C)	
Enclosure Ratings	Nema 4, 4X, 7, 9 Watertight and Explosion-proof	
	Class I Groups C&D, Div. 1&2	
	Class II Groups E, F&G, Div. 1&2	
Motor Types	AC:	Permanent Split Capacitor, Class B Insulation
	DC:	Brush
AC Motor Thermal Protection	Automatically resetting	
Travel and Aux. Switches	SPDT, Form C	
	15 amp 125 VAC ½ HP, 10 amp 250 VAC, ½ amp 125 VDC	
Conduit Connections	¾-14 NPT	
Manual Override	300 In-lbs max input	
Corrosion Protection	Chromate conversion undercoat with polyester electrostatic powder top coat	
Terminal Strip Hookup	300V, 30 amp, 12-26 AWG	
Lubrication	Permanently lubricated	
Gear Train	Heat treated alloy steel able to withstand stall torque	

Note: The above ratings may change depending on model configurations and options provided. Products may differ as the result of the Company policy of continuous product improvement.

Motor Option	Motor Voltage	Duty Cycle <sup>(1,3)</sup>	Run Current (Amps)	Locked Rotor (Amps)	Cycle Times in Seconds per 90 Degrees				
					Actuator Model				
					CE2	CE4	CE7	CE1	CE5
Std.	115 AC	25	1.1	1.3	3	5	6	11	18
A	115 AC	Extended: 75	0.5	0.6	6	10	17	24	36
B	12 DC	100	1.6	3.0 <sup>(2)</sup>	6	9	16	21	32
C	24 DC	100	0.9	2.0 <sup>(2)</sup>	6	8	15	20	30
D	230 AC	25	0.7	0.8	3	5	6	11	18
F	230 AC	Extended: 75	0.3	0.4	6	10	17	24	36
J	24 AC	100	0.5	0.8	3	5	6	11	18

Torque and Weights					
Torque (In-Lbs)	250	400	700	1000	1500
Torque (N-M)	28	45	79	113	169
Weight (Lbs)	18	18	18	18	20
Weight (Kg)	8	8	8	8	9

### Notes:

- Duty cycle is the limit of "on" time as percentage of total cycle time. For example, the CE2 with standard motor runs 3 seconds to open or close the valve. The motor must remain off for 9 seconds prior to starting the close cycle. DC motors may be operated continuously.
- Do not lock up DC motors.
- CE5 duty cycles for AC motors are 20% for standard duty and 70% for extended duty.
- For 180 degree applications, simply multiply the above cycle times by 2.

## Troubleshooting

### Problem

There is power to the unit, but it does not respond.

### Solution

Check the nameplate to see that the correct voltage has been applied.

Check the wiring to see that it is per the wiring schematic.

Check the limit switches to see if they are in the normal operating range.

Check the manual override. If it is in the down position, the motor is electrically disconnected.

### Problem

Power is getting to the motor, but it merely hums.

### Solution

Check to see that the proper voltage is applied. Make sure all the connections are tight.

Check to see that the brake coil is pulling the brake pad and hinge away from the fan.

Check to see that CW and CCW power connections are not powered at the same time.

### Problem

The actuator performs erratically.

### Solution

Check to see that the actuator is not stalling.

Check the ambient temperature rating. The permanent split capacitor units are equipped with thermal cut-outs. Excessive temperatures and cycle frequencies may heat the motor up and the thermal cut-out turns it off.



**United States**  
Flowserve Corporation  
Flowserve Flow Control  
1978 Foreman Drive  
Cookeville, TN 38501  
Tel 931 432 4021  
Fax 931 432 5518

FCD AXENIM0037-01 Printed in USA. (Replaces AUTO-37)

***To find your local Flowserve representative:***

For more information about Flowserve Corporation, visit  
[www.flowserve.com](http://www.flowserve.com) or call USA 1 800 225 6989

Flowserve Corporation has established industry leadership in the design and manufacture of its products. When properly selected, this Flowserve product is designed to perform its intended function safely during its useful life. However, the purchaser or user of Flowserve products should be aware that Flowserve products might be used in numerous applications under a wide variety of industrial service conditions. Although Flowserve can (and often does) provide general guidelines, it cannot provide specific data and warnings for all possible applications. The purchaser/user must therefore assume the ultimate responsibility for the proper sizing and selection, installation, operation, and maintenance of Flowserve products. The purchaser/user should read and understand the Installation Operation Maintenance (IOM) instructions included with the product, and train its employees and contractors in the safe use of Flowserve products in connection with the specific application.

While the information and specifications contained in this literature are believed to be accurate, they are supplied for informative purposes only and should not be considered certified or as a guarantee of satisfactory results by reliance thereon. Nothing contained herein is to be construed as a warranty or guarantee, express or implied, regarding any matter with respect to this product. Because Flowserve is continually improving and upgrading its product design, the specifications, dimensions and information contained herein are subject to change without notice. Should any question arise concerning these provisions, the purchaser/user should contact Flowserve Corporation at any one of its worldwide operations or offices.

© 2005 Flowserve Corporation, Irving, Texas, USA. Flowserve is a registered trademark of Flowserve Corporation.