



# Clemas & Co Ltd

Industrial Cleaning Equipment  
Sales - Hire - Service

## CT110 RIDE-ON SCRUBBER DRYER OPERATOR MANUAL



**Clemas & Co.** Unit 5 Ashchurch Business Centre, Alexandra Way, Tewkesbury,  
Gloucestershire, GL20 8NB.

**Tel:** 01684 850777

**Fax:** 01684 850707

**Email:** [info@clemas.co.uk](mailto:info@clemas.co.uk)

**Web:** [www.clemas.co.uk](http://www.clemas.co.uk)

# ***ENGLISH***

*(Translation of original instructions)*

# 1. CONTENTS

<b>1. CONTENTS</b> .....	<b>2</b>
<b>2. GENERAL INFORMATION</b> .....	<b>4</b>
2.1. SCOPE OF THE MANUAL .....	4
2.2. IDENTIFYING THE MACHINE .....	5
2.3. DOCUMENTATION PROVIDED WITH THE MACHINE .....	5
<b>3. TECHNICAL INFORMATION</b> .....	<b>5</b>
3.1. GENERAL DESCRIPTION .....	5
3.2. LEGEND .....	5
3.3. DANGER ZONES .....	5
<b>4. SAFETY INFORMATION</b> .....	<b>6</b>
4.1. SAFETY REGULATIONS .....	6
<b>5. HANDLING AND INSTALLATION</b> .....	<b>9</b>
5.1. LIFTING AND TRANSPORTING THE PACKAGED MACHINE .....	9
5.2. CHECKS ON DELIVERY .....	9
5.3. UNPACKING .....	9
5.4. BATTERIES .....	10
5.4.1. Batteries: preparation .....	10
5.4.2. Batteries: installation and connection .....	10
5.4.3. Batteries: removal .....	11
5.5. THE BATTERY CHARGER .....	11
5.5.1. Choosing the battery charger .....	11
5.5.2. Preparing the battery charger .....	11
5.6. LIFTING AND TRANSPORTING THE MACHINE .....	12
<b>6. PRACTICAL GUIDE FOR THE OPERATOR</b> .....	<b>12</b>
6.1. CONTROLS - DESCRIPTION .....	12
• <i>DISK RELEASE BUTTON</i> (FIG. A, REF. 16): MICRO SCRUB / ECS MACHINE, ENABLES AUTOMATIC RELEASE OF THE MICROFIBRE DISK, BRUSH OR ABRASIVE DISK FROM THE HEAD. ....	13
6.2. MOUNTING AND ADJUSTING THE SQUEEGEE .....	13
6.3. MOUNTING AND CHANGING THE BRUSH/ABRASIVE DISKS (STANDARD MACHINE). ....	13
6.4. AUTOMATIC ATTACHMENT AND RELEASE OF THE MICROFIBRE DISK/BRUSHES/ABRASIVE DISKS (MICRO SCRUB / ECS MACHINE) .....	14
ATTACHING: .....	14
RELEASING: .....	14
6.5. DETERGENTS - INSTRUCTIONS .....	14
6.6. PREPARING THE MACHINE FOR WORK .....	14
6.7. ADJUSTING THE RIDING POSITION .....	15
6.8. WORKING .....	15
<b>7. PERIODS OF INACTIVITY</b> .....	<b>18</b>
<b>8. BATTERY MAINTENANCE AND CHARGING</b> .....	<b>18</b>
8.1. PROCEDURE FOR CHARGING USING THE BATTERY CHARGER INSTALLED BY THE MANUFACTURER	18
8.2. PROCEDURE FOR CHARGING USING AN EXTERNAL BATTERY CHARGER .....	19
<b>9. MAINTENANCE INSTRUCTIONS</b> .....	<b>19</b>
9.1. MAINTENANCE - GENERAL RULES .....	19
9.2. ROUTINE MAINTENANCE .....	19
9.2.1 Suction motor air filter and float: cleaning .....	19
9.2.2 Detergent solution filter: cleaning .....	19
9.2.3 Squeegee blades: replacing .....	20
9.2.4 Fuses: replacing .....	20
9.3. REGULAR MAINTENANCE .....	20
9.3.1. Daily operations .....	20

9.3.2.	<i>Weekly operations</i> .....	20
9.3.3.	Six monthly operations.....	21
<b>10.</b>	<b>TROUBLESHOOTING AND ERROR CODES</b> .....	<b>22</b>
10.1.	HOW TO RESOLVE POSSIBLE PROBLEMS .....	22
10.2.	ALARMS DISPLAYED.....	25
10.3.	MOTOR DRIVE ALARM BOARD.....	26

## 2. GENERAL INFORMATION



**Read this manual carefully before carrying out any work on the machine<sup>1</sup>.**

### 2.1. Scope of the manual

This manual has been written by the Manufacturer and is an integral part of the machine. It defines the purpose for which the machine has been designed and constructed and contains all the information required by operators.

In addition to this manual containing all user information, other publications are available providing specific information for maintenance personnel.

Constant respect for the instructions guarantees the safety of the operator and the machine, low running costs and high quality results and extends the working life of the machine. Failure to respect the instructions may lead to damage to the operator, machine, floor being washed and environment.

To find the topic that interests you more rapidly, consult the list of contents at the beginning of the manual.

Parts of the text requiring special attention are highlighted in bold and preceded by the symbols illustrated and described here.

### **! DANGER**

**Indicates the need for attention in order to avoid a series of consequences which could cause death or damage to the health of the operator.**

### **👉 IMPORTANT**

**Indicates the need for attention in order to avoid a series of consequences which could cause damage to the machine or work environment or financial loss.**

### **i INFORMATION**

**Particularly important instructions.**

In line with the company's policy of constant product development and updating, the Manufacturer reserves the right to make modifications without warning.

Although your machine may differ appreciably from the illustrations in this document, safety and the information contained in this manual are guaranteed.

---

<sup>1</sup> The definition "machine" replaces the trade name of the appliance to which this manual refers.

## 2.2. Identifying the machine

The rating plate under the seat (fig. B, ref. 8) provides the following information:

- model;
- power supply;
- total nominal power;
- serial number;
- year of fabrication;
- weight fully loaded;
- maximum slope;
- barcode with serial number;
- manufacturer's identification.

## 2.3. Documentation provided with the machine

- user manual;
- guarantee certificate;
- EC certificate of conformity.

# 3. TECHNICAL INFORMATION

## 3.1. General description

This machine is a scrubber drier for sweeping, washing and drying flat, horizontal, smooth or moderately rough, even and obstacle free floors in civil and industrial premises.

The scrubber drier spreads a solution of water and detergent in the correct concentration on the floor and then scrubs it to remove the dirt. By carefully choosing the detergent and brushes (or abrasive discs) from the wide range of accessories available, the machine can be adapted to a wide range of combinations of types of floor and dirt.

A suction system incorporated in the machine dries the floor after washing by means of the low pressure generated in the collection tank by the suction motor. The squeegee connected to the tank collects the dirty water.

## 3.2. Legend

The main parts of the machine are as follows (fig. B):

- detergent solution tank (fig. B, ref. 1): contains and transports the mixture of clean water and cleaning product;
- collection tank (fig. B, ref. 2): collects the dirty water picked up from the floor after washing;
- control panel (fig. B, ref. 3);
- head assembly (fig. B, ref. 4): the main element is the brushes, the abrasive disk or the microfibre disk (fig. B, ref. 5) which distribute the detergent solution on the floor and remove the dirt;
- squeegee assembly (fig. B, ref. 6): wipes and dries the floor by collecting the water.
- concentrated solution tanks (**OPTIONAL**) (fig. C, ref. 1)
- battery compartment (fig. C, ref. 2)
- battery charger (**OPTIONAL**) (fig. C, ref. 3)

## 3.3. Danger zones

A **-Tank assembly**: when using certain detergents, danger of irritation for eyes, skin, mucous membranes and respiratory tract and of asphyxia. Danger represented by the dirt collected from the environment (germs and chemical substances). Danger of crushing between the two tanks when the collection tank is replaced on the solution tank.

B **-Control panel**: danger of short circuit.

- C -**Bottom of washing head:** danger due to brush rotation.
- D -**Rear wheels:** danger of crushing between the wheel and chassis.
- E -**Battery compartment:** danger of short circuit between the battery poles and presence of hydrogen during charging.

## 4. SAFETY INFORMATION

### 4.1. Safety regulations



**Read the "User manual" carefully before start-up and use, or before performing maintenance or any other work on the machine.**

### **IMPORTANT**

**Rigorously respect all instructions in the Manual (in particular those relating to danger and important information) and on the safety plates fitted to the machine. The Manufacturer declines all liability for damage to people or things resulting from failure to observe the instructions.**

The appliance must be used exclusively by persons trained in its use and/or who have demonstrated their ability and have been expressly instructed to use the appliance.

The machine must not be used by minors.

The machine must not be used for purposes other than those for which it was expressly designed. Scrupulously respect all safety standards and conditions applicable to the type of building in which the machine is to be operated (eg: pharmaceutical companies, hospitals, chemicals, etc).

Do not use the machine in places with inadequate lighting or explosive atmospheres, on public roads, in the presence of dirt hazardous to health (dust, gas, etc) and in unsuitable environments.

The machine is designed for use at temperatures of between +4°C and +35°C. When the machine is not being used, the temperature range is +0°C and +50°C.

The machine is designed to work in a humidity of between 30% and 95%.

Never use or pick up flammable liquids or explosives (eg. petrol, fuel oil, etc), flammable gases, dry dusts, acids and solvents (eg. paint solvents, acetone etc) even if diluted. Never pick up flaming or incandescent objects.

Never use the machine on slopes or ramps of more than 16%. In the case of slight slopes, do not use the machine transversally, always manoeuvre with care and do not reverse. When transporting the machine on steeper ramps or slopes, take the utmost care to avoid tipping up and/or uncontrolled acceleration. Move the machine on ramps and/or steps only with the brush head and squeegee raised.

**Never park the machine on a slope.**

The machine must never be left unattended with the motors on. Before leaving it, turn the motors off, make sure it cannot move accidentally and disconnect the electrical power supply.

Always pay attention to other people, children in particular, present in the place where you are working.

Never use the machine to transport people or things or to tow things. Do not tow the machine.

Never rest objects of any weight on the machine for any reason.

Never obstruct ventilation and heat dispersion slits.

Never remove, modify or circumvent safety devices.

Numerous unpleasant experiences have shown that a wide range of personal objects may cause serious accidents. Before beginning work, remove jewellery, watches, ties, etc.

The operator must always use personal protection devices - protective apron or overalls, non-slip waterproof shoes, rubber gloves, protective goggles and ear protectors and mask to protect the respiratory tract.

Keep the hands away from moving parts.

Never use detergents other than those specified. Follow the instructions on the relative safety sheet. We recommend keeping detergents out of reach of children. In the event of contact with the eyes, wash immediately with abundant water. If ingested, consult a doctor immediately.

Make sure the power sockets used for the battery charger are connected to a suitable earth system and protected by differential thermal solenoid switches.

Make sure the electrical characteristics of the machine (voltage, frequency, absorbed power) given on the rating plate are the same as those of the mains electricity supply. The earth wire is yellow and green. Never connect this wire to anything other than the earth contact of the socket.

It is indispensable to respect the battery manufacturer's instructions and current legislation. The batteries should always be kept clean and dry to avoid surface leakage current. Protect the batteries from impurities such as metal dust.

Never rest tools on the batteries as this could cause short circuit and explosion.

When using battery acid, always follow the relative safety instructions scrupulously.

In the presence of particularly strong magnetic fields, assess the possible effect on the control electronics.

Never wash the machine with water jets.

The fluids collected contain detergent, disinfectant, water and organic and inorganic material. They must be disposed off in accordance with current legislation.

In the case of malfunction and/or faulty operation, turn the machine off immediately, disconnect from the mains power supply or batteries and do not tamper. Contact a service centre authorised by the Manufacturer.

All maintenance operations must be performed in an adequately lit place and only after isolating the machine from the power supply by disconnecting the battery terminals.

All work on the electrical system and all maintenance and repair operations other than those explicitly described in this manual must be performed by specialised personnel expert in the sector only.

Only original accessories and spare parts supplied by the Manufacturer may be used in order to guarantee safe problem-free operation of the machine. Never use parts removed from other machines or from other kits.

This machine has been designed and constructed to provide ten years' service from the fabrication date shown on the rating plate. After this time, whether the machine has been used or not, it should be disposed of according to current legislation in the country in which it is used:

- the machine must be disconnected from the power supply, emptied of liquids and cleaned;
- the product is classified as WEEE type special waste and is covered by the requisites of the new environmental protection regulations (2002/96/EC WEEE). It must be disposed of separately from ordinary waste in compliance with current legislation and standards.



**Special waste. Do not dispose of with ordinary waste.**

Alternatively the machine must be returned to the Manufacturer for a complete overhaul.

If you decide to stop using the machine, you are recommended to remove the batteries and dispose of them at an authorised collection centre.



You should also make sure that all parts of the appliance which could represent a hazard, particularly to children, are made safe.

## 5. HANDLING AND INSTALLATION

### 5.1. Lifting and transporting the packaged machine

#### IMPORTANT

**During all lifting operations, make sure the packaged machine is firmly anchored to avoid it tipping up or being accidentally dropped.**

**Always load/unload lorries in adequately lit areas.**

The machine, packaged on a wooden pallet by the Manufacturer, must be loaded using suitable equipment (see EC Directive 2006/42 and subsequent amendments and/or additions) onto the transporting vehicle. At destination, it must be unloaded using similar means.

The squeegees are packed in cardboard boxes without pallet.

A fork lift truck must always be used to lift the packaged body of the machine. Handle with care to avoid knocking or overturning the machine.

### 5.2. Checks on delivery

When the carrier delivers the machine, make sure the packaging and machine are both whole and undamaged. If the machine is damaged, make the carrier is aware of the damage and before accepting the goods, reserve the right (in writing) to request compensation for the damage.

### 5.3. Unpacking

#### IMPORTANT

**When unpacking the machine, the operator must be provided with the necessary personal protection devices (gloves, goggles, etc) to limit the risk of accident.**

Unpack the machine as follows:

- cut and remove the plastic straps using scissors or nippers;
- remove the cardboard;
- depending on the model, remove the metal brackets or cut the plastic straps fixing the machine chassis to the pallet;
- using a sloping ramp, push the machine backwards off the pallet;
- unpack the brushes and squeegees;
- clean the outside of the machine in respect of safety regulations;
- once the machine is clear of the packaging, the batteries can be installed.

The packaging may be kept as it can be reused to protect the machine if it is moved to another site or to a repair workshop.

Otherwise it must be disposed off in compliance with current legislation.

## ! DANGER

**Failure to observe these instructions could cause possibly serious damage to people and things and invalidates the guarantee.**

### 5.4. Batteries

Two different types of battery may be installed on these machines:

- **wet batteries:** the electrolyte level must be checked regularly. When necessary, top up with distilled water until the plates are covered. Do not over fill (5 mm max. above the plates).
- **gel batteries:** this type of battery requires no maintenance.

The technical characteristics must correspond to those indicated in the paragraph on the technical specification of the machine. The use of heavier batteries could seriously jeopardise manoeuvrability and lead to the brush motor overheating. Batteries with a lower capacity and weight will require recharging more frequently.

They must be kept charged, dry and clean and the connections must be tight.

## i INFORMATION

Follow the instructions below to set the type of battery installed on the machine's logic board.

1. Switch off the machine by turning the main switch (fig. A, ref. 1) to the 0 position.
2. Press the emergency button (fig. A ref. 10) (red light on).
3. Hold the solution/concentrated detergent flow quantity variation buttons (fig. A, ref. 2) down and simultaneously press the emergency button (fig. A, ref. 10) (red light off). Keep the solution/concentrated detergent flow quantity variation buttons pressed (fig. A, ref. 2) until "tip A", "tip G" appears on the display.
4. Use the solution flow regulation button (fig. A, ref. 3) to select the type of batteries installed: "tip A" wet batteries, "tip G" gel batteries.
5. Memorise the parameter by pressing the emergency button (fig. A ref. 10).

#### 5.4.1. Batteries: preparation

## ! DANGER

**During installation of the batteries or any type of battery maintenance, the operator must be provided with the necessary personal protection devices (gloves, goggles overalls, etc) to limit the risk of accident. Keep away from naked flames, avoid short circuiting the battery poles, avoid sparks and do not smoke.**

The batteries are normally supplied filled with acid and ready for use.

If the batteries are dry, before mounting them on the machine, proceed as follows:

- remove the caps and fill all elements with specific sulphuric acid solution until the plates are entirely covered (this requires at least a couple of passes for each element);
- leave for 4-5 hours to allow the air bubbles to come to the surface and the plates to absorb the electrolyte;
- make sure the level of electrolyte is still above the plates and if necessary top up with sulphuric acid solution;
- close the caps;
- mount the batteries on the machine (following the procedure described below).

Before starting up the machine for the first time, charge the batteries as follows.

#### 5.4.2. Batteries: installation and connection

## ! DANGER

**Check that all switches on the control panel are in the "0" (off) position. Make sure you connect the terminals marked with a "+" to the positive poles of the battery. Do not check the battery charge by sparking.**

**Meticulously follow the instructions given below as short circuiting the batteries could cause them to explode.**

- 1) Make sure the two tanks are empty (if necessary, empty them. See the relevant paragraph).
- 2) Raise the solution tank and tilt it backwards **ACCOMPANYING IT** through about 90°. This provides access to the battery compartment from above.

## **IMPORTANT**

before lifting the solution tank, always remove the suction hose fitted to the squeegee.

- 3) Place the batteries in the battery compartment.

## **IMPORTANT**

**Mount the batteries on the machine using means suitable for their weight.  
The positive and negative poles have different diameters.**

- 6) Referring to the arrangement of cables shown in the diagram (fig. D), connect the battery cable and bridge terminals to the battery poles.  
Arrange the cables as shown in the diagram (fig. D), tighten the terminals on the poles and cover with Vaseline.
- 7) Lower the tank into the working position
- 8) When using the machine, follow the instructions below.

### 5.4.3. Batteries: removal

## **! DANGER**

**When removing the batteries, the operator must be equipped with suitable personal protection devices (gloves, goggles, overalls, safety shoes, etc) to reduce the risk of accidents. Make sure the switches on the control panel are in the "0" position (off) and the machine is turned off. Keep away from naked flames, do not short circuit the battery poles, do not cause sparks and do not smoke. Proceed as follows:**

- disconnect the battery wiring and bridge terminals from the battery poles.
- if necessary, remove the devices fixing the battery to the base of the machine.
- lift the batteries from the compartment using suitable lifting equipment.

### 5.5. The battery charger

## **IMPORTANT**

**Never allow the batteries to become excessively flat as this could damage them irreparably.**

#### 5.5.1. Choosing the battery charger

Make sure the battery charge is compatible with the batteries to be charged:

- **tubular lead batteries:** an automatic charger is recommended
- Consult the battery charger manufacturer and manual to confirm the choice.
- **gel batteries:** use a charger specific for this type of battery.

#### 5.5.2. Preparing the battery charger

If you wish to use a battery charger not provided with the machine, you must fit it with the connector supplied with the machine.

To install the connector, proceed as follows:

- remove about 13 mm of protective sheath from the red and black wires of the battery charger;
- insert the wires into the connector contacts and squeeze them forcefully with suitable pliers;
- respect the polarity (red wire + black wire -) when inserting the wires into the connector.
  - Insert the wired-up connector into the connector on the machine (fig. C, ref. 4).

## 5.6. Lifting and transporting the machine

### **IMPORTANT**

**All phases must be performed in an adequately lit room and adopting the safety measures most appropriate to the situation.**

**The operator must always use personal protection devices.**

To load the machine onto a means of transport, proceed as follows:

- empty the collection and solution tanks;
- remove the squeegee and brushes (or abrasive disks);
- remove the batteries;
- place the machine on the pallet and fix it with plastic straps or metal brackets;
- lift the pallet (with the machine) using a fork lift truck and load it onto the means of transport;
- anchor the machine to the means of transport with cables connected to the pallet and machine itself.

## 6. PRACTICAL GUIDE FOR THE OPERATOR

### 6.1. Controls - Description

These terms have the following meanings:

**STANDARD MACHINE**, version of the machine designed for use with brushes or abrasive disks.

**MICRO SCRUB / ECS MACHINE**, version of the machine designed for use with microfibre disk, brushes or abrasive disks.

With reference to fig. A, the machine has the follow controls and indicator lights:

- **Power light** (fig. A, ref. 5): consists of 4 LEDs indicating the battery charge level (see paragraph 6.7)
- **Main Switch** (fig. A, ref. 1): enables and disables the electrical power supply to all machine functions.
- **Emergency button** (fig. A, ref. 10): acts as a safety device.
- **Speed potentiometer** (fig. A, ref. 13): regulates the speed of the machine forwards and backwards
- **Solution flow regulation button** (fig. A, ref. 3): there are five operating modes
  - STANDARD
  - AUTOMATIC
  - ECONOMY.
  - MICROFIBRE (MICRO SCRUB / ECS MACHINE)
  - CHEM-DOSE
- **Solution/concentrated detergent flow quantity variation buttons** (fig. A, ref. 2): vary the flow of solution/concentrated detergent
- **Display** (fig. A, ref. 6):

- a) displays the quantity of concentrated detergent when enabled.
- b) displays alarm codes.
- c) displays hour counter.
- **Horn button** (fig. A, ref. 12):
- **Suction button** (fig. A, ref. 9): enables/disables the suction function. If you press this button for more than five seconds, the suction motor starts working even without the operator on board.
  - **Brush button** (fig. A, ref. 8):
    - STANDARD MACHINE, enables/disables operation of the head.
    - MICRO SCRUB / ECS MACHINE, enables/disables operation of the head. Hold the button down for at least 3 seconds to select the operating mode, "BRUSH-PAD" with brushes/abrasive disk, or "MICROFIBRE" with microfibre disk.
- **Solution tank level indicator**: (fig. A, ref. 14): when there is not enough water in the solution tank, the LED comes on and the head and solenoid valve are turned off **(OPTIONAL)**
- **Collection tank level indicator** (fig. A, ref. 11): when the collection tank is full, the LED comes on and after a few seconds the suction motor is turned off.
- **Head pressure variation buttons** (fig. A, ref. 7): vary the pressure of the brushes on the floor
- **Motor drive board indicator** (fig. A, ref. 15): indicates the status of the motor drive board (see section: "Motor drive alarm board").
- **Disk release button** (fig. A, ref. 16): MICRO SCRUB / ECS MACHINE, enables automatic release of the microfibre disk, brush or abrasive disk from the head.

## 6.2. Mounting and adjusting the squeegee

The squeegee (fig. B, ref. 6) is responsible for the first phase of drying.

To mount the squeegee on the machine, proceed as follows:

- 1) insert the sleeve of the suction hose (fig. E, ref. 1) fully into the squeegee;
- 2) slacken the two knobs (fig. E, ref. 2) at the centre of the squeegee;
- 3) insert the two threaded pins into the slots on the support (fig. E, ref. 3)
- 4) fix the squeegee by tightening the two knobs (fig. E, ref. 2)

The squeegee blades scrape the film of water and detergent from the floor and prepare the way for perfect drying. With time, the constant rubbing makes the edge of the blade in contact with the floor rounded and cracked, reducing the drying efficiency and requiring it to be replaced. The state of wear should be checked frequently.

For perfect drying, the squeegee must be adjusted in such a way that the edge of the rear blade bends during operation by about 45° with respect to the floor at every point. Adjust the angle of the blade during operation by regulating the height of the two wheels positioned in front of/behind the squeegee.

## 6.3. Mounting and changing the brush/abrasive disks (STANDARD MACHINE).

### IMPORTANT

**Never work without the brushes and abrasive disks perfectly installed.**

**The terms RIGHT and LEFT refer to the forward movement of the machine**

#### **Mounting the right brush (or abrasive disk)**

- remove the right and left side hatches (fig. L, ref. 2);
- position the right brush (fig. M, ref. 1) under the drive disk (fig. M, ref. 2)
- lift the right brush (fig. M, ref. 1) and turn it clockwise to block it on the drive disk (fig. M, ref. 3)

#### **Mounting the left brush (or abrasive disk)**

- Follow the same procedure as used to mount the right brush, blocking it on the drive disk by turning it anticlockwise.

#### **Removing the right brush (or abrasive disk)**

- rotate the brush anticlockwise (fig. M, ref. 1) to release it from the drive disk (fig. M, ref. 3)
- Replace the right and left side hatches (fig. L, ref. 2);

#### **Removing the left brush (or abrasive disk)**

- Follow the same procedure as used to remove the right brush, releasing it from the drive disk by turning it clockwise.

### **6.4. Automatic attachment and release of the microfibre disk/brushes/abrasive disks (MICRO SCRUB / ECS MACHINE)**

## **IMPORTANT**

**Never operate the machine without the disks correctly installed.**

#### **ATTACHING:**

- Raise the side flaps on both sides and position the disks under the housing, making sure they rest against the stops to align them with the attachment device.
- Press the brush button (fig. A, ref. 8) and the machine performs the automatic attachment manoeuvre

#### **RELEASING:**

- Turn off the head and suction motors and all devices.
- Press the release button (fig. A, ref. 16) and hold for five seconds. The machine performs the automatic release manoeuvre.

### **6.5. Detergents - Instructions**

## **IMPORTANT**

**Always dilute the detergent according to the manufacturer's instructions. Do not use sodium hypochlorite (bleach) or other oxidants, particularly in strong concentrations. Do not use solvents or hydrocarbons. The temperature of the water and detergent must not exceed the maximum indicated in the technical specification. They must be free of sand and/or other impurities.**

The machine has been designed for use with low-foam biodegradable detergents made specifically for scrubber driers.

For a complete and up-to-date list of the detergents and chemicals available, contact the Manufacturer.

Use products suitable for the floor and dirt to be removed only.

Follow the safety regulations on use of detergents given in the section "Safety regulations".

### **6.6. Preparing the machine for work**

## **IMPORTANT**

**Before starting work, wear overalls, ear protectors, non-slip waterproof shoes, mask to protect the respiratory tract, gloves and all other personal protection devices recommended by the supplier of the detergent used or necessitated by the work environment.**

Before starting work, proceed as follows:

- check the battery charge (recharge if necessary);
- make sure the collection tank (fig. B, ref. 2) is empty. If necessary, empty it;

- via the opening (fig. C, ref. 5) under the seat, fill the solution tank with a suitable concentration of clean water and low-foam detergent. leave at least 5 cm between the surface of the liquid and the opening of the tank;
- mount the most suitable brushes, abrasive disks or microfibre disks for the floor and work to be performed.
- make sure the squeegee (fig. B, ref. 6) is firmly attached and connected to the suction hose (fig. E, ref. 1). Make sure the back blade is not worn.

## i INFORMATION

**If you are using the machine for the first time, we recommend trying it on a large obstacle-free surface first to acquire the necessary familiarity.**

**Always empty the collection tank before filling the solution tank again.**

For effective cleaning and to extend the working life of the machine, follow a few simple rules:

- prepare the work area by removing all possible obstacles;
- begin working from the furthest point to avoid walking on the area you have just cleaned;
- choose the straightest possible working routes;
- divide large floors into parallel rectangular sections.

If necessary, finish off by passing a mop or rag rapidly over parts inaccessible to the scrubber drier.

### 6.7. Adjusting the riding position

To make the machine comfortable to use, the angle of the steering wheel (fig. B, ref. 9) can be adjusted using the lever (fig. B, ref. 11).

### 6.8. Working

#### **Starting up:**

- Prepare the machine as described above.
- When starting up the machine, follow the sequence below precisely:
  1. Sit on the seat (safety sensors are activated)
  2. Turn the main switch (fig. A, ref. 1) into the "1" position without pressing the drive pedal (fig. B, ref. 7), check the battery charge as shown by the indicator light (fig. A, ref. 5). If the red LED flashes or is on steadily, or if the red and yellow LEDs are both on, turn the main switch back to the "0" position and recharge the batteries (see chapter 8).
  3. Use the drive pedal (fig. B, ref. 7).
- Take the machine to the work area by starting it up with your hands on the steering wheel and pressing the pedal (fig. B, ref. 7) on the front to move forwards and on the back to move backwards. The speed can be adjusted from zero to maximum by adjusting the pressure exerted on the pedal (fig. B, ref. 7).

## i INFORMATION

- **The seat (fig. B, ref. 8) has two safety sensors which allow the machine to move only when the operator is seated.**



The machine has a safety system to prevent it tipping over. This reduces the speed on bends, irrespective of the pressure exerted on the drive pedal. This reduction of speed on bends is therefore not a malfunction, but a feature which increases the machine's stability in all conditions.

- Press the brush button (fig. A, ref. 8). This command functions differently depending on whether you are using the "**STANDARD MACHINE**" or the "**MICRO SCRUB / ECS MACHINE**":
  - STANDARD MACHINE**, it enables machine operation (head and suction motors, head actuator);
  - MICRO SCRUB / ECS MACHINE**, it enables machine operation (head and suction motors, head actuator) and if held down for at least five seconds, selects the machine operating mode, **BRUSH-PAD** with brushes/abrasive disk or **MICROFIBRE** with microfibre disk. The LED corresponding to the operating mode selected (BRUSH-PAD, or MICROFIBRE) lights up.
- Select the most suitable pressure for the head on the floor according to the type of washing to be performed using the buttons (fig. A, ref. 7).
- Select the most suitable flow according to the type of washing to be performed using the button (fig. A, ref. 3). There are five options
  - 1 **STANDARD**, the solution flow can be modified using the buttons (fig. A, ref. 2) (**STANDARD MACHINE ONLY**)
  - 2 **AUTOMATIC**, the solution flow is set by the machine according to the speed (**STANDARD MACHINE ONLY**).
  - 3 **ECONOMY**, the solution flow is fixed at the lowest level (**STANDARD MACHINE ONLY**).
  - 4 **CHEM-DOSE STANDARD MACHINE**, enables the solution tank pump (**OPTIONAL**). To enter CHEM-DOSE mode, hold the button (fig. A, ref. 3) down until the red LED corresponding to CHEM-DOSE comes on. To vary the quantity of solution, you must first disable the programmes (STANDARD, AUTOMATIC, ECONOMY) by pressing the button (fig. A, ref. 3). The quantity of solution can now be adjusted using the buttons (fig. A, ref. 2) and the value set appears on the display (fig. A, ref. 6). Once the quantity of solution has been set, the most suitable type of solution flow must be selected (STANDARD, AUTOMATIC, ECONOMY) using the button (fig. A, ref. 3). To disable the solution tank pump, hold the button (fig. A, ref. 3) down for at least five seconds until the LED corresponding to CHEM-DOSE goes out.
  - 5 **CHEM-DOSE MICRO SCRUB / ECS MACHINE** enables the solution tank pump (**OPTIONAL**). To enter CHEM-DOSE mode, hold the button (fig. A, ref. 3) down until the red LED corresponding to CHEM-DOSE comes on. To vary the quantity of solution, you must first disable the programmes (STANDARD, AUTOMATIC, ECONOMY) by pressing the button (fig. A, ref. 3). The quantity of solution can now be adjusted using the buttons (fig. A, ref. 2) and the value set appears on the display (fig. A, ref. 6). Once the quantity of solution has been set, for BRUSH-PAD mode only, the most suitable type of solution flow must be selected (STANDARD, AUTOMATIC, ECONOMY) using the button (fig. A, ref. 3). When using CHEM-DOSE in MICROFIBRE mode, you cannot use the STANDARD, AUTOMATIC and ECONOMY programmes. To vary the flow, use the buttons (fig. A, ref. 2) only. To disable the solution tank pump, hold the button (fig. A, ref. 3) down for at least five seconds until the LED corresponding to CHEM-DOSE goes out.
  - 6 **MICROFIBRE**, the solution flow can be varied using the buttons (fig. A, ref. 2) (**MICRO SCRUB / ECS MACHINE ONLY**)

- Start cleaning, manoeuvring with the hands on the steering wheel (fig. B, ref. 9) and moving the machine forwards or backwards by pressing the pedal (fig. B, ref. 7).
- The working speed can be set using the maximum speed regulator (fig. A, ref. 13).

## **IMPORTANT**

**To avoid damaging the surface of the floor to be treated, avoid rotating the brushes/pads/microfibre disks with the machine stationary.**

### **Stopping:**

- Release the pedal (fig. B, ref. 7)
- The machine does not have a parking brake as it is fitted with an electromagnetic brake which automatically brakes the machine when the drive pedal is not pressed.
- To stop all functions, press the brush button (fig. A, ref. 8).
- Turn the main switch (fig. A, ref. 1) to the "0" position.

### **Running down of the batteries during work:**

## **IMPORTANT**

**To avoid damaging the batteries and shortening their working life, do not continue using the machine once the batteries are flat.**

The meaning of the battery charge control light (fig. A, ref. 5) is given below:

**1 flashing red LED:** battery voltage under 18 V (ACID batteries) or under 19 V (GEL batteries), drive is shut down. Recharge the batteries.

**1 red LED on steadily:** battery voltage between 18 and 20.5 V (ACID batteries) or 19 and 21.5 V (GEL batteries), **SUPER-MINIMUM** battery charge. Recharge the batteries.

**1 red LED + 1 yellow LED on steadily:** battery voltage between 20.5 and 21.5 V (ACID batteries) or 21.5 and 22.5 V (GEL batteries), **MINIMUM** battery charge.

**1 red LED + 1 yellow LED + 1 green LED\_1 on steadily:** battery voltage between 21.5 and 24 V (ACID batteries) or 22.5 and 25 V (GEL batteries), **MEDIUM** battery charge.

**1 red LED + 1 yellow LED + 1 green LED\_1 + 1 green LED\_2 on steadily:** battery voltage between 24 and 27.4 V (ACID batteries) or 25 and 28.4 V (GEL batteries), **MAXIMUM** battery charge.

## **IMPORTANT**

**Each time you fill the solution tank, always empty the collection tank.**

## **! DANGER**

**Use suitable personal protection devices.**

- when the collection tank is full, the level indicator comes on (fig. A, ref. 11) and after a few seconds the suction motor is turned off. You must stop working and empty the tank.

### **Emptying the collection tank:**

- 1 Stop the machine by releasing the pedal (fig. B, ref. 7)
- 2 Turn off all functions using the brush button (fig. A, ref. 8).
- 3 Take the machine to the disposal area.
- 4 Empty the collection tank through the hose (fig. B, ref. 10), then rinse the tank with clean water.

### Emptying the solution tank:

- 5 Proceed as described in points 1 to 3.
- 6 At the end of work, empty the solution tank by by unscrewing the cap (fig. E, ref. 4), then rinse the tank with clean water.

## IMPORTANT

before lifting the solution tank, always remove the suction hose fitted to the squeegee.

## IMPORTANT

**When washing the collection tank, never remove the suction filter (fig. G, ref. 1) from its housing and never direct the jet of water against the filter itself.**

You are then ready to wash and dry again.

### Pushing and pulling the machine:

When the drive cannot be used, to push or pull the machine easily, you must block the electromagnetic brake by screwing up the screws (fig. F, ref. 1) .

After moving the machine, unscrew the screws to release the electromagnetic brake.

## IMPORTANT

**If the screws are not unscrewed, the electromagnetic brake remains inactive. Never turn the machine on with the screws (fig. F, ref. 1) screwed up (brake deactivated).**

## 7. PERIODS OF INACTIVITY

If the machine is not used for some time, remove the squeegee and brushes (or abrasive disks), wash them and put them away in a dry place (preferably in a bag or wrapped in plastic film) away from dust.

Make sure the tanks are completely empty and perfectly clean.

Completely recharge the batteries before storing them. During long periods of inactivity, you should charge the batteries regularly (at least once every two months) to keep them constantly at maximum charge.

## IMPORTANT

**If you do not charge the batteries regularly, they may be irrevocably damaged.**

## 8. BATTERY MAINTENANCE AND CHARGING

### ! DANGER

**Do not check the battery by sparking.**

**The batteries give off flammable fumes. Put out all fires and hot embers before checking or topping up the batteries.**

**Perform the operations described above in a ventilated room.**

### 8.1. Procedure for charging using the battery charger installed by the Manufacturer

- Raise the seat (fig. B, ref. 8) and connect the battery charge cable (fig. C, ref. 5) to the mains power supply.

## 8.2. Procedure for charging using an external battery charger

- Raise the seat (fig. B, ref. 8) and connect the battery charge connector to the red connector (fig. C, ref. 4).
- Turn the battery charger on

## IMPORTANT

**In the case of gel batteries, use a charger specific for gel batteries only.**

- Charge the batteries as described in the battery charger manual;

# 9. MAINTENANCE INSTRUCTIONS

## ! DANGER

**Never perform any maintenance operations without first disconnecting the batteries from the machine's electrical circuit.**

**Maintenance on the electrical circuit and all other operations not explicitly described in this manual must be performed by specialised personnel only, in compliance with current safety legislation and as described in the maintenance manual.**

### 9.1. Maintenance - General rules

Performing regular maintenance according to the Manufacturer's instructions improves performance and extends the working life of the machine.

When cleaning the machine, respect the following:

- avoid the use of water cleaners. Water could penetrate the electrical compartment or motors leading to damage or the risk of short circuit;
- do not use steam to avoid the heat warping plastic parts;
- do not use hydrocarbons or solvents as they could damage the cowling and rubber parts.

### 9.2. Routine maintenance

#### 9.2.1 Suction motor air filter and float: cleaning

- Raise the cover (fig. G, ref. 2) of the collection tank;
- make sure the collection tank (fig. B, ref. 2) is empty;
- clean the collection tank float, taking care not to direct the water jet directly against the float;
- remove the suction motor air filter from the float support (fig. G ref. 1) inside the collection tank at the top;
- clean the filter with running water or the detergent used on the machine;
- dry the filter thoroughly before replacing it in the support. Make sure the filter is correctly located in its housing;
- Close the collection tank cover.

#### 9.2.2 Detergent solution filter: cleaning

- Before cleaning the filter, close the tap (fig. H ref. 2) upstream of the filter.
- Unscrew the filter cap (fig. H ref. 1);
- Remove the filter from its housing by pulling downwards;

- Clean the filter with running water or the detergent used on the machine;
- Replace the filter in its housing
- Screw up the filter cap

### 9.2.3 Squeegee blades: replacing

The squeegee blades collect the film of water and detergent from the floor and prepare the way for perfect drying. With time, the constant rubbing makes the edge of the blade in contact with the floor rounded and cracked, reducing the drying efficiency and requiring it to be replaced.

#### **Turning or replacing the blades:**

- remove the squeegee (fig. B ref. 6) from its support (fig. E ref. 3) by completely unscrewing the two knobs (fig. E ref. 2)
- remove the sleeve of the suction hose (fig. E, ref. 1) from the squeegee;
- release the clip or unscrew the bolt (fig. I ref. 3 or 6);
- remove the two blade retainers (fig. I ref. 2 or 7) by first pushing them towards the body of the squeegee (fig. I ref. 1) then extracting them;
- remove the blade (fig. I ref. 4 or 5);
- reuse the same blade by reversing the edge in contact with the floor until all four edges are worn out, or replace with a new blade, fitting it onto the screws on the body of the squeegee (fig. I ref. 1);
- reposition the two blade retainers (fig. I ref. 2 or 7) by centring the widest part of the slots over the fixing screws on the squeegee body (fig. I ref. 1), then pushing the blade retainers inwards;
- fix the clip or screw up the bolt (fig. I ref. 3 or 6);

Replace the squeegee in its support following the instructions in paragraph 6.2.

### 9.2.4 Fuses: replacing

- turn the main switch (fig. A, ref. 1) to the "0" position.
- remove the cover of the electrical compartment (fig. L)
- check the fuses (fig. L ref. 1)
- replace with a new fuse.
- close the cover

**Fuse table:** For the complete fuse table, see the spare parts catalogue.

## **IMPORTANT**

**Never use a fuse with a higher amperage than specified.**

If a fuse continues to blow, the fault in the wiring, boards (if present) or motors must be identified and repaired. Have the machine checked by qualified personnel.

## 9.3. Regular maintenance

### 9.3.1. Daily operations

- After each day's work, proceed as follows:
- empty the collection tank and clean if necessary;
- clean the squeegee blades and check for wear. If necessary, replace.
- check that the suction hole in the squeegee is not blocked. If necessary remove encrusted dirt;
- recharge the batteries according to the procedure described.

### 9.3.2. Weekly operations

- Clean the collection tank float and make sure it is working correctly;

- clean the suction air filter and make sure it is undamaged. If necessary, replace.
- clean the suction hose;
- clean the collection and solution tanks;

## **IMPORTANT**

before lifting the solution tank, always remove the suction hose fitted to the squeegee.

- check the level of battery electrolyte and top up with distilled water if necessary.

### **9.3.3. Six monthly operations**

Have the electricity circuit checked by qualified personnel.

# 10. TROUBLESHOOTING AND ERROR CODES

## 10.1. How to resolve possible problems

PROBLEM	CAUSE	SOLUTION
<b>The machine does not function</b>	the batteries are disconnected	connect the batteries to the machine
	the batteries are flat	recharge the batteries
<b>The brushes do not turn</b>	The emergency button is pressed (fig. A ref. 10)	Press the emergency button (fig. H ref. 2)
	the brush button has not been pressed	press the brush button
	The collection tank is full	Empty the collection tank
	the brush motor fuse has blown	check and remove the causes of the blown fuse, then replace
	the batteries are flat	recharge the batteries
<b>The machine does not clean evenly</b>	motor malfunction	have the motor replaced
	the brushes or abrasive disks are worn	replace
<b>No solution is delivered</b>	The tap (fig. H ref. 2) upstream of the filter is closed	Open the tap
	the solution tank is empty	Fill it.
	the hose delivering the solution to the brush is blocked	remove the obstruction to open the hose
<b>The solution flow does not stop</b>	Dirty solenoid valve	Check the solenoid valve
	Faulty solenoid valve	Replace the solenoid valve
	Solenoid valve wiring	Check the solenoid valve wiring
<b>The flow of solution is interrupted during operation</b>	Dirty solenoid valve	Check the solenoid valve
	Faulty solenoid valve	Replace the solenoid valve
	Solenoid valve wiring	Check the solenoid valve wiring
<b>The suction motor does not start.</b>	The suction switch (fig. A ref. 9) has not been activated	activate the suction switch (fig. A ref. 9)
	there is no power to the suction motor or motor malfunction	make sure the motor power supply connector is correctly connected to the main wiring. In the latter case, have the motor replaced
	the fuse is blown.	replace the fuse.
	Collection tank full	Empty the collection tank
<b>The squeegee does not clean or suction is ineffective</b>	the edge of the rubber blades in contact with the floor is worn	replace the rubber blade
	the squeegee or hose is blocked or damaged	remove the obstruction and repair the damage
	the float switch has tripped (collection tank full), is blocked with dirt or is faulty	empty the collection tank or repair the float
	the suction hose is blocked	unblock the hose
	the hose is not connected to the squeegee or is damaged	connect or repair the hose
	there is no power to the suction motor or motor malfunction	make sure the motor power supply connector is correctly connected to the main wiring and that the fuse is not blown. In the latter case, have the motor replaced.
<b>The machine does not move</b>	the batteries are flat	recharge the batteries
	Problem with the motor drive	verify the alarm code (see paragraph 10.3)
	The emergency button is pressed (fig. A ref. 10)	Press the emergency button

<b>The machine does not brake</b>	Electromagnetic brake lock handwheel/screws unscrewed (fig. F ref. 1)	Screw up the handwheel/screws (fig. F ref. 1) see paragraph 6.7
	Electromagnetic brake malfunction	replace
<b>The batteries do not last as long as usual</b>	the battery poles and terminals are dirty and oxidised	clean and grease the poles and terminals, charge the batteries
	the level of electrolyte is low	add distilled water, topping up each element according to the instructions
	the battery charger does not work or is not adequate	see the battery charger instructions
	there are considerable differences in density between the various elements of the battery	replace the damaged battery
<b>The battery runs down too rapidly during use, even though it has been charged with the correct procedure and at the end of charging it is evenly charged when tested by a hydrometer.</b>	the battery is new and does not provide 100% of the expected performance	the battery must be run in by performing 20-30 complete charging and running down cycles to obtain the maximum performance
	the machine is used for the maximum of its power for continuous periods and the run time is insufficient	when permitted and possible, use batteries with a higher capacity or replace the batteries with others already charged
	the electrolyte has evaporated and does not completely cover the plates	add distilled water, topping up each element until it covers the plates then recharge the battery
<b>The battery runs down too rapidly during use, charging with the electronic battery charger is too fast and at the end the battery provides the correct voltage (about 2.14 V per element without load), but appears to be uniformly not charged when tested with a hydrometer</b>	the battery supplied by the manufacturer already filled with acid has been stored too long before being charged and used for the first time	if recharging with the normal battery charger is not effective, perform a double charge: - charge it slowly over a 10 hour period at a current of 1/10 the nominal capacity for 5 hours (eg. for a 100Ah(5) battery the current must be set at 10A, using a manual battery charger); - rest for one hour; - charge it with the normal battery charger.
<b>At the end of charging with the electronic battery charger, the battery does not provide the correct voltage (about 2.14 V per element without load) and appears to be uniformly not charged when tested with a hydrometer</b>	the battery has not been connected to the battery charger (for example, because the low voltage battery charger connector has been incorrectly connected to the machine connector)	connect the battery charger to the battery connector
	the battery charger and socket to which it is connected are not compatible.	make sure the characteristics of the power supply shown on the battery charger rating plate are the same as those of the mains electricity supply.
	the battery charger has not been correctly installed	taking into account the actual voltage available at the power socket, make sure that the connections of the primary of the transformer inside the battery charger are correct (consult the battery charger manual)



	the battery charger does not work	make sure there is voltage to the battery charger, that the fuses are not blown and that the current reaches the battery; try charging with another rectifier. If the battery charger is not working, contact the technical service centre and indicate the serial number of the battery charger
<b>At the end of charging with the electronic battery charger, the battery does not provide the correct voltage (about 2.14 V per element without load) and only one or a few elements appear flat when tested with the hydrometer</b>	one or more elements are damaged	if possible, replace the damaged elements. For 6 or 12 V single block batteries, replace the entire battery
<b>The electrolyte in the battery is turbid</b>	the battery has reached the end of the charging/discharging cycles declared by the manufacturer	replace the battery
	the battery has been charged with too high a current	replace the battery
	the battery has been charged beyond the maximum limit recommended by the manufacturer	replace the battery

## 10.2. Alarms displayed

<b>NO24</b>	Battery below minimum level (18V)
<b>NOFR</b>	Main fuse blown or power relay malfunction
<b>NOEP</b>	EEPROM management error
<b>FH20</b>	No water in tank.
<b>SH20</b>	Dirty water tank full
<b>OFF</b>	Machine shutting down
<b>R (xxx)</b>	Software release
<b>CD (xx)</b>	Chemical DOSE quantity
<b>STOP</b>	Motor drive board deactivated (operator not seated) or motor drive overheat sensor tripped.

### 10.3. Motor drive alarm board

The board controlling the motor drive is located inside the front upright (fig. C ref. 6). If drive is interrupted, the error code should be identified by means of the status LED. In the absence of malfunctions, the status LED is steadily on while the machine is in operation. If a malfunction is detected, the status LED provides two types of information, a slow flash (2 Hz) or a rapid flash (4 Hz) to indicate the severity of the malfunction.

Malfunctions with a slow flash are cancelled automatically once the malfunction has been repaired and the machine functions normally again. Malfunctions with a rapid flash ("\*" in the table) are considered more serious. The machine must be turned of using the key switch (fig. A ref. 1) to reset operation after repairing the malfunction.

The indication of severity remains active for 10 seconds, after which the status LED flashes constantly showing a two digit malfunction code until the repairs have been carried out.

For example, error code "1,4" is displayed as follows:

☼ ☼☼☼ **example alarm code 1,4**

LED CODES		DESCRIPTION
	1,1	☼ ☼
	1,2	☼ ☼☼
	1,3	☼ ☼☼☼
	1,4	☼ ☼☼☼☼
	1,5	☼ ☼☼☼☼☼
	2,1	☼☼☼ ☼
	2,3	☼☼☼ ☼☼☼
	2,4	☼☼☼ ☼☼☼☼
*	3,1	☼☼☼☼ ☼
	3,2	☼☼☼☼ ☼☼
	3,3	☼☼☼☼ ☼☼☼☼
	3,4	☼☼☼☼ ☼☼☼☼☼
	3,5	☼☼☼☼ ☼☼☼☼☼☼
*	4,1	☼☼☼☼☼☼ ☼
*	4,2	☼☼☼☼☼☼ ☼☼☼
*	4,3	☼☼☼☼☼☼ ☼☼☼☼
*	4,4	☼☼☼☼☼☼ ☼☼☼☼☼☼

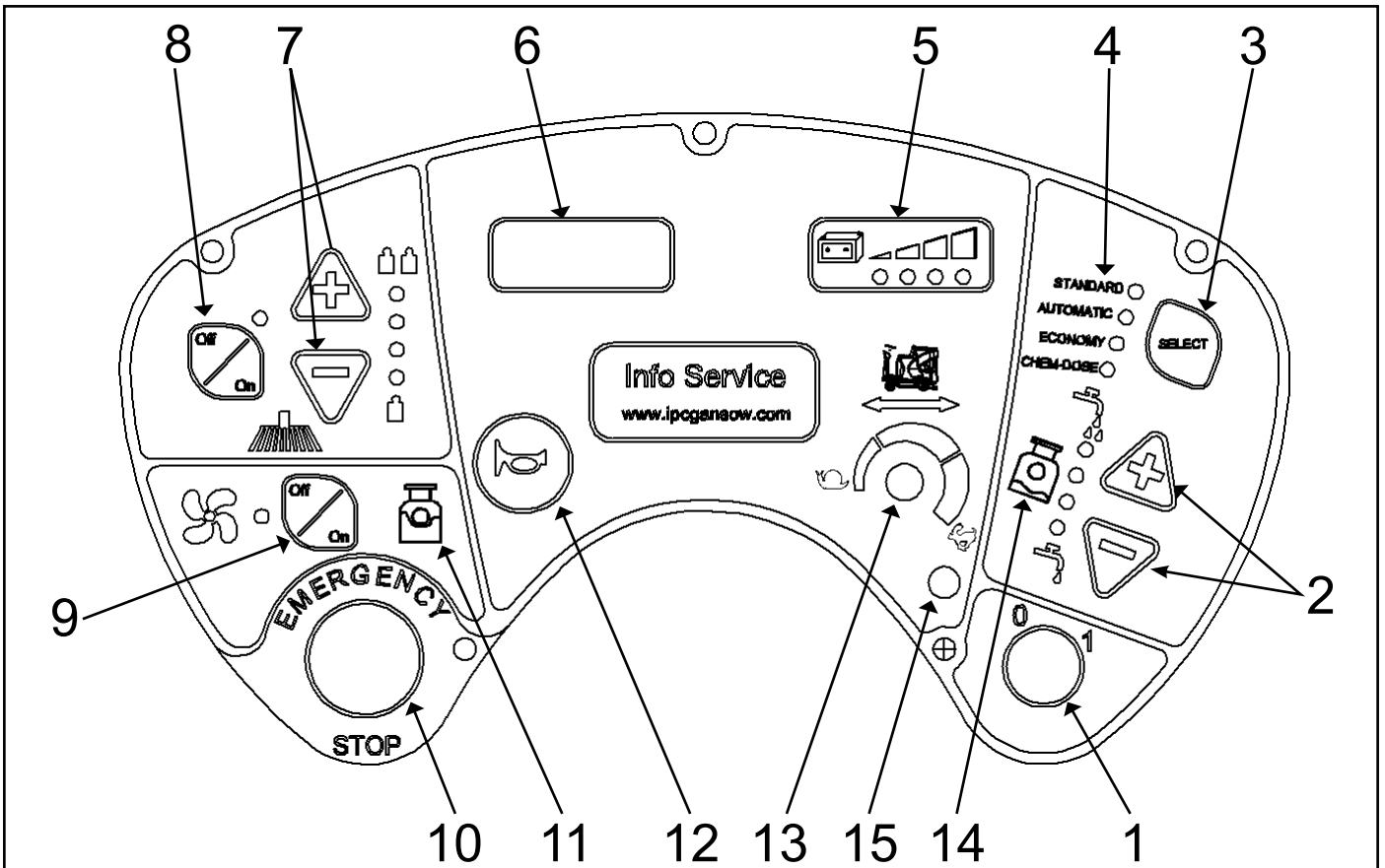

**A - STANDARD**

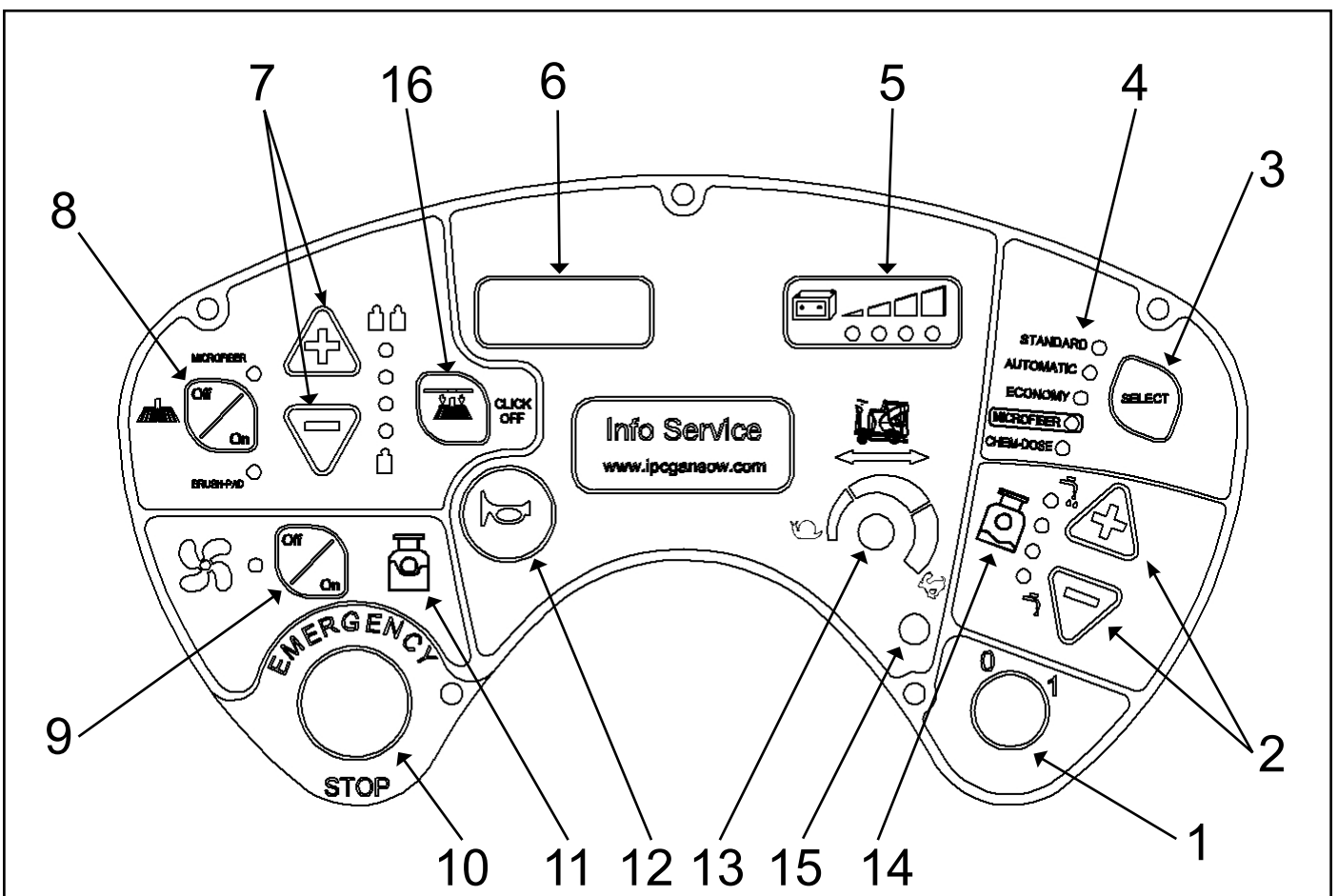

**A - MICRO SCRUB / ECS**

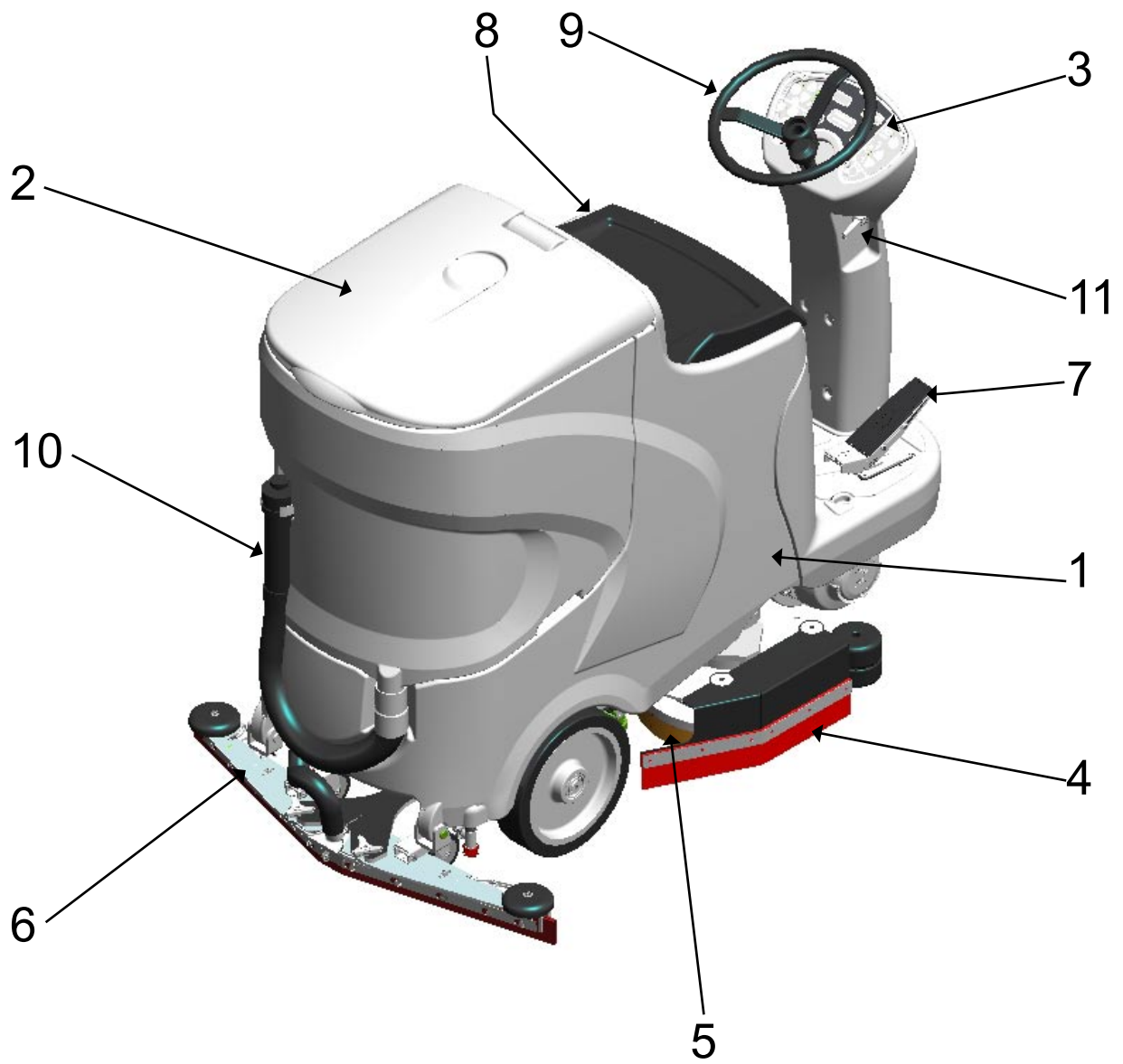

**B**

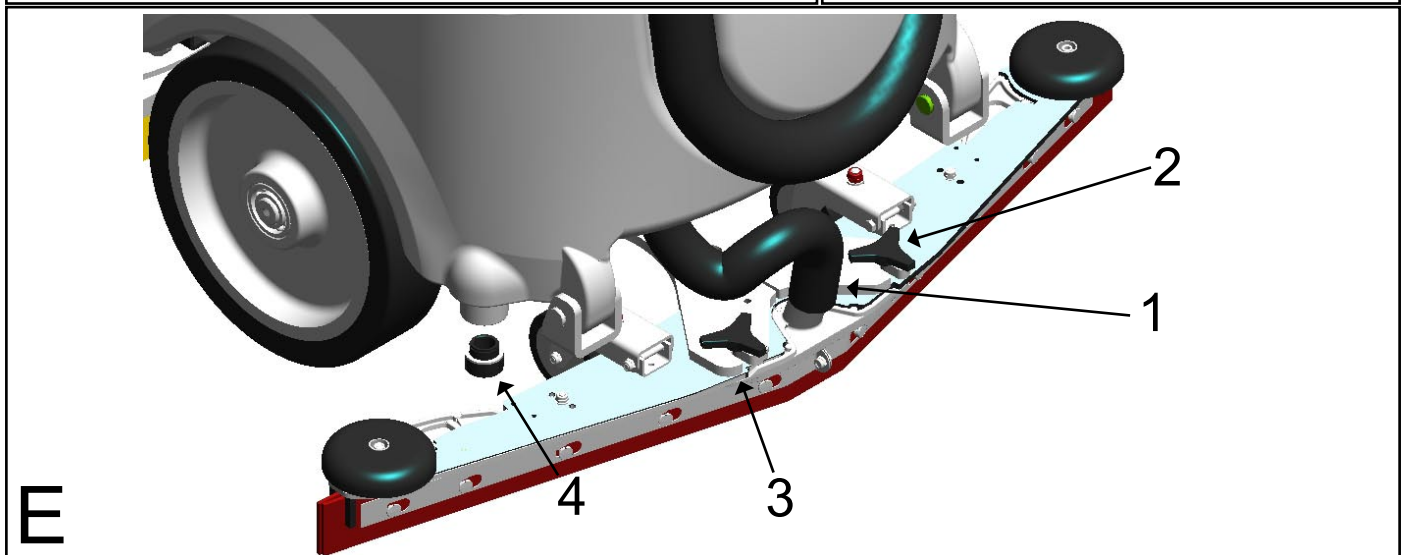
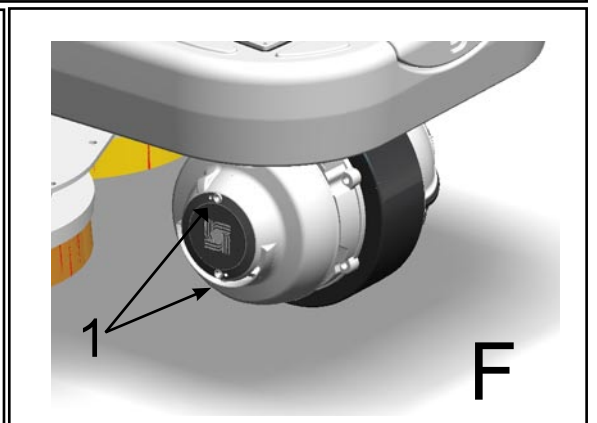
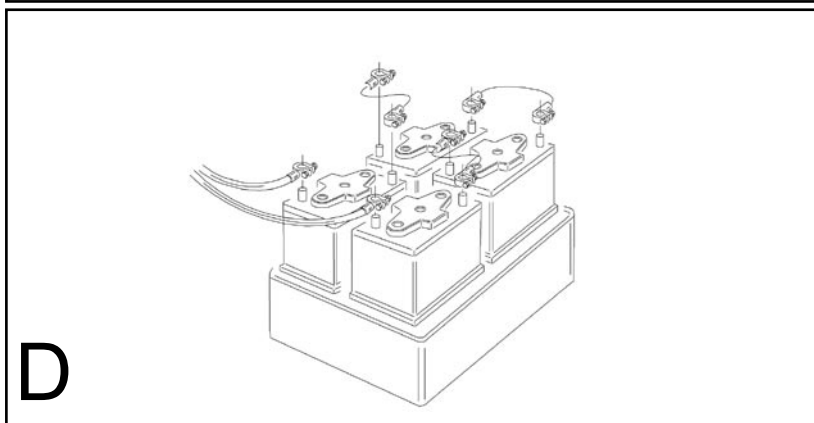
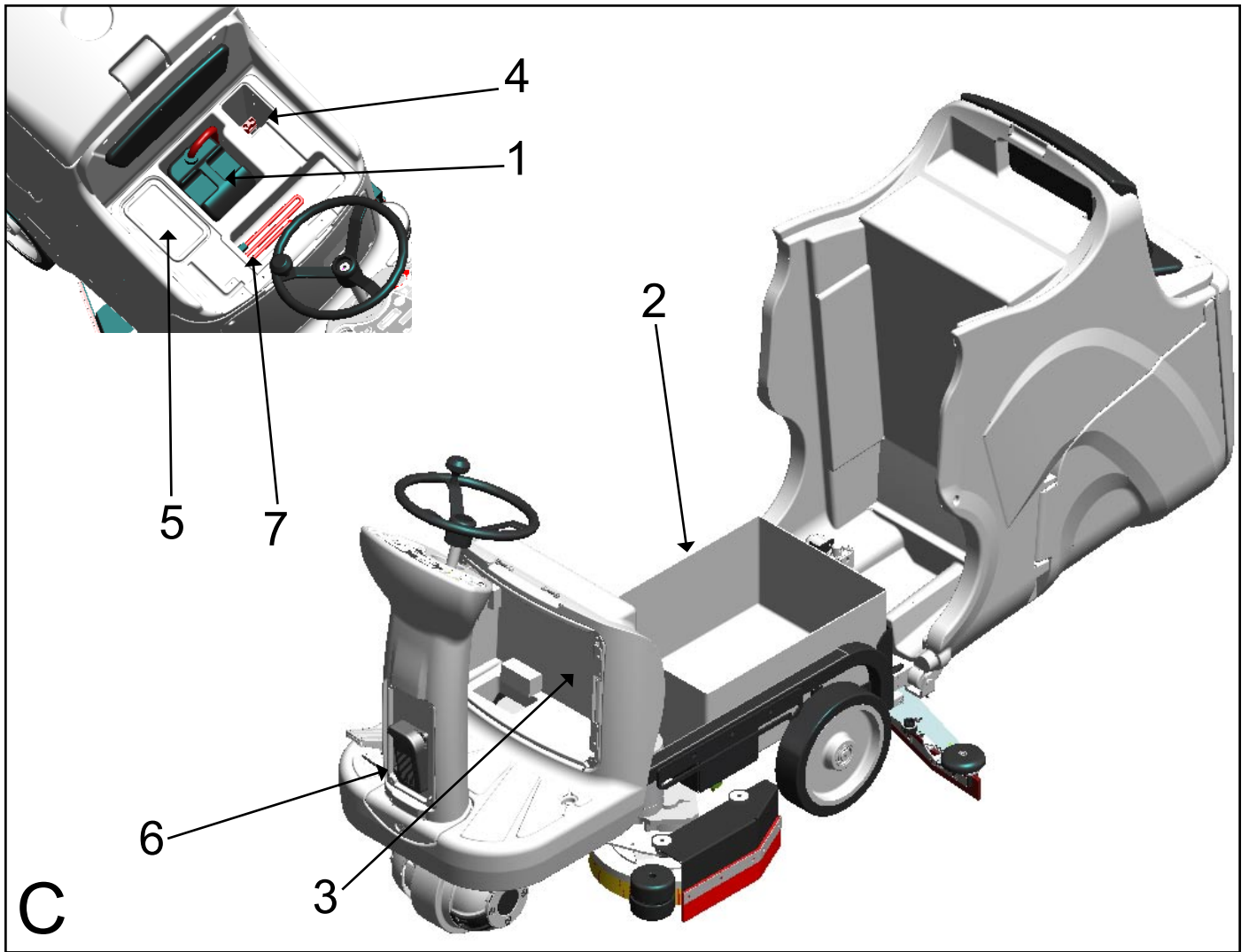

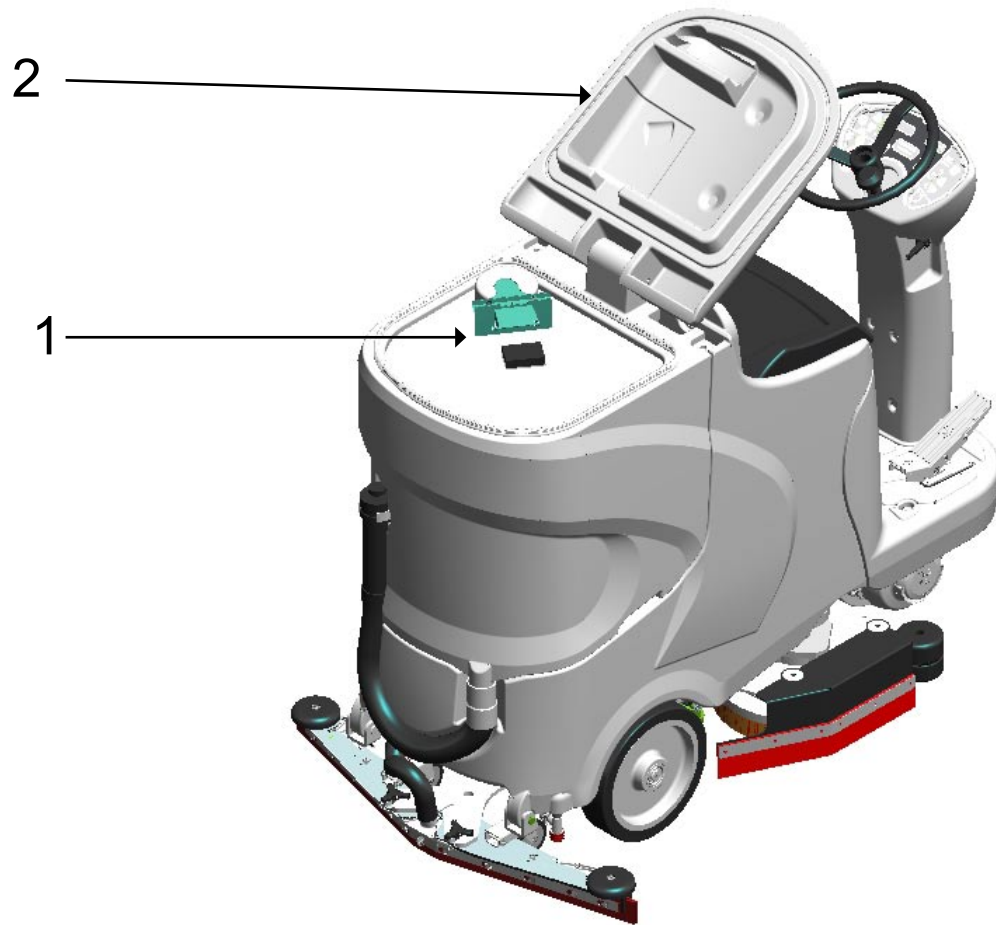

G

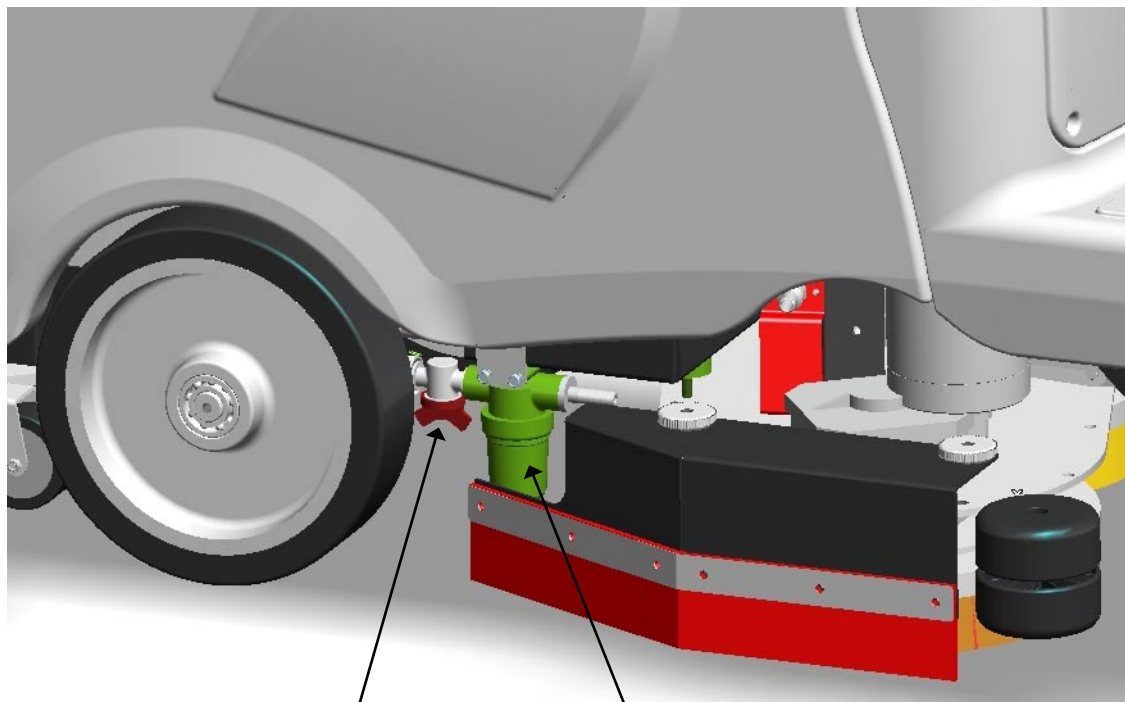

H

