

### Masterdock™ Docking Station



### **WARNING**

***READ AND FOLLOW THE ENTIRE CONTENT OF THIS MANUAL PRIOR TO USE. FAILURE TO DO SO MAY RESULT IN SERIOUS INJURY OR DEATH.***

This Page Left Intentionally Blank

## Table of Contents

1.	Safety and General Information .....	1
1.1.	Important Notices .....	1
1.2.	Warnings, Cautions, and Notes.....	2
1.2.1.	General Warnings and Cautions .....	3
1.2.2.	General Rules for Use of the Masterdock .....	3
1.3.	Warranty Statement .....	4
1.3.1.	Contacting Scott Health & Safety .....	4
1.4.	Acronyms Quick Reference.....	5
2.	Introduction .....	7
3.	Setup and Mounting.....	9
3.1.	Mounting the Masterdock.....	9
3.2.	Powering the Masterdock.....	10
3.3.	Connecting Calibration Gas .....	10
3.4.	Secure Digital Memory Card .....	11
3.4.1.	Formatting an SD Card .....	12
3.5.	Air Filter.....	12
3.6.	Installing Software.....	12
4.	Operation .....	13
4.1.	Bump Testing and Calibration .....	13
4.2.	LED Alerts and Displays.....	13
4.3.	Masterdock Utility .....	14
4.3.1.	Connecting Masterdock to a PC.....	14
4.3.2.	Masterdock Utility Modes .....	14
4.3.3.	Masterdock Utility Main Display .....	15
4.3.4.	Masterdock Utility Menus .....	15
4.3.4.1.	Operation Menu .....	16
4.3.4.2.	Option Menu.....	17
4.3.4.3.	View Menu .....	17
4.3.4.4.	Help Menu.....	18
5.	Parts List and Maintenance.....	19
5.1.	Cleaning and Routine Maintenance .....	19
5.2.	Troubleshooting .....	20
5.3.	Scott Repairs.....	21

This Page Left Intentionally Blank

## List of Figures

Figure 2-1.	Masterdock Components .....	8
Figure 3-1.	Masterdock Wall Mounting Dimensions .....	9
Figure 3-2.	Installing Calibration Gas .....	10
Figure 3-3.	Installing SD Memory Card .....	11
Figure 4-1.	Masterdock Utility Main Display .....	15
Figure 4-2.	Masterdock Utility Operation Menu .....	16
Figure 4-3.	Masterdock Utility Option Menu .....	17
Figure 4-4.	Masterdock Utility View Menu .....	17
Figure 4-5.	Masterdock Utility Help menu .....	18

This Page Left Intentionally Blank

## List of Tables

Table 1-1.	Acronym Quick Reference List .....	5
Table 2-1.	Masterdock Components .....	8
Table 4-1.	Status LED Indications.....	13
Table 5-1.	Parts List.....	19
Table 5-2.	Troubleshooting Chart .....	20

## Record of Revisions

<b>Revision</b>	<b>Date</b>	<b>Description</b>
A	04/09	Initial release
B	08/09	Updated LED indications and troubleshooting table
C	09/09	Updated P/N's
D	10/09	Updated P/N's
E	01/10	Updated Table 4-1 and 5-2.



## 1. Safety and General Information

---

### **WARNING**

*ALL INDIVIDUALS WHO HAVE OR WILL HAVE RESPONSIBILITY FOR USING OR TESTING THIS PRODUCT MUST READ AND UNDERSTAND THE CONTENTS OF THIS MANUAL. THE PRODUCT WILL PERFORM AS DESIGNED ONLY IF USED AND TESTED IN ACCORDANCE WITH THE MANUFACTURER'S INSTRUCTIONS. FAILURE TO FOLLOW MANUFACTURER'S INSTRUCTIONS WILL RENDER THE WARRANTY AND APPROVALS NULL AND VOID. FAILURE TO FOLLOW THESE INSTRUCTIONS MAY ALSO RESULT IN SERIOUS INJURY OR DEATH.*

#### 1.1. Important Notices

Scott Health and Safety can take no responsibility for use of its equipment if it is not used in accordance with the instructions. If further operational or maintenance details are required but not provided in this manual, contact Scott Health and Safety or their agent. Scott Health and Safety shall not be liable for any incidental or consequential damages in connection with any modifications, errors or omissions in this manual. While every effort has been made to ensure accuracy in this owner's manual, no responsibility can be accepted for errors or omissions. This publication is not intended to form the basis of a contract, and the company reserves the right to amend the design, content, and specifications of the detector without notice. Additionally, industry standards, codes, and legislation are subject to change. Updated copies should be obtained by users to ensure the most recently issued regulations, standards and guidelines are available.

## 1.2. Warnings, Cautions, and Notes

Throughout this document, warnings, cautions, and notes have been interspersed to draw attention to potentially unsafe, hazardous, or unique situations that require user attention. Each warning, caution, or note is labeled and quickly identified using an icon.

***WARNING - INDICATES A POTENTIALLY HAZARDOUS SITUATION, WHICH, IF NOT AVOIDED, COULD RESULT IN DEATH OR SERIOUS INJURY.***

***CAUTION - INDICATES A POTENTIALLY HAZARDOUS SITUATION THAT, IF NOT AVOIDED, MAY RESULT IN MINOR OR MODERATE INJURY. IT MAY ALSO BE USED TO ALERT AGAINST UNSAFE PRACTICES.***

***NOTE - HIGHLIGHTS VARIOUS INSTANCES WHERE AN ATTENTION TO DETAIL IS CRITICAL TO PRODUCT PERFORMANCE.***

### 1.2.1. General Warnings and Cautions

The following list of warnings and cautions pertain to the general use and care of the Masterdock. Failure to follow these warnings and cautions may result in death, injury, or poor equipment performance.

#### **WARNINGS**

***USE THE MASTERDOCK ONLY IN AN ATMOSPHERE THAT HAS BEEN VERIFIED TO BE FREE OF TOXIC OR COMBUSTIBLE GASES OR VAPORS.***

***THE MASTERDOCK IS NOT FOR USE WITH ANY OTHER PRODUCT THAN THE PROTÉGÉ PORTABLE GAS MONITOR.***

#### **CAUTIONS**

***VERIFY THE GAS INLET PORT HAS A CLEAN FILTER ATTCHED AND AN UNOBSTRUCTED FLOW PATH PRIOR TO USE.***

***DO NOT USE A MAGNET NEAR THE SD MEMORY CARD TO PREVENT LOSING OR CORRUPTING DATA.***

***DO NOT USE ANY SOLVENTS, CHEMICALS, OR POLISHES CONTAINING SILICON COMPOUNDS TO CLEAN THE MASTERDOCK AS THESE CAN CAUSE DAMAGE TO THE SENSORS OF THE PROTÉGÉ.***

### 1.2.2. General Rules for Use of the Masterdock

It is critical that this docking station be used and maintained properly. Failure to do so could jeopardize the people whose lives depend on its operation and cause injury or death.

- **USE THE DOCKING STATION CORRECTLY.** Only use the Masterdock to bump test and calibrate Scott's Protégé portable gas monitor.
- **POWER MUST BE ON TO WORK.** The Masterdock will only function while powered on.
- **VERIFY CALIBRATION CYLINDERS ARE SUFFICIENTLY CHARGED.** Calibration cylinders must have at least 50 psi of pressure to accurately calibrate or bump test Protégé units.
- **DO NOT USE CALIBRATION GAS BEYOND THE EXPIRATION DATE.** Verify Calibration gas has not exceeded its expiration date prior to use.
- **DO NOT USE IN UNKNOWN OR POTENTIALLY HAZARDOUS ATMOSPHERES.** Always verify an atmosphere is free of toxic or combustible gases prior to powering up the Masterdock. Keep the air filter clean to prevent contaminants from entering the units air system.

### 1.3. Warranty Statement

## SCOTT HEALTH & SAFETY LIMITED WARRANTY ON Masterdock™ Docking Station

Scott Health & Safety (SCOTT), a division of Scott Technologies Inc. warrants its MASTERDOCK DOCKING STATION (THE PRODUCTS) to be free from defects in workmanship and materials for a period of one (1) year from the date of original manufacture by SCOTT. This warranty applies to all components of THE PRODUCTS supplied at the time of original sale of THE PRODUCTS. SCOTT's obligation under this warranty is limited to replacing or repairing (at SCOTT's option) THE PRODUCTS or components shown to be defective in either workmanship or materials.

Only personnel of SCOTT or, when directed by SCOTT, authorized SCOTT agents are permitted to perform warranty obligations. This warranty does not apply to defects or damage caused by any repairs of or alterations to THE PRODUCTS made by owner or any third party unless expressly permitted by SCOTT product manuals or by written authorization from SCOTT. To obtain performance under this warranty, and as a condition precedent to any duty of SCOTT, the purchaser must return such products to SCOTT, a SCOTT authorized distributor or a SCOTT authorized service center. Any product returned to SCOTT shall be sent to "SCOTT HEALTH & SAFETY" (Attn: Warranty Claim Dept.), P.O. Box 569, Monroe, NC 28111.

This warranty does not apply to any malfunction of or damage to THE PRODUCTS resulting from accident, alteration, misuse, or abuse.

THIS WARRANTY IS MADE IN LIEU OF ALL OTHER WARRANTIES, EXPRESSED OR IMPLIED INCLUDING, BUT NOT LIMITED TO, ANY IMPLIED WARRANTY OF MERCHANTABILITY OR FITNESS FOR A PARTICULAR PURPOSE. IN ADDITION, SCOTT EXPRESSLY DISCLAIMS ANY LIABILITY FOR SPECIAL, INCIDENTAL OR CONSEQUENTIAL DAMAGES IN ANY WAY CONNECTED WITH THE SALE OR USE OF SCOTT PRODUCTS, AND NO OTHER FIRM OR PERSON IS AUTHORIZED TO ASSUME ANY SUCH LIABILITY.

#### 1.3.1. Contacting Scott Health & Safety

To contact Scott Health & Safety, call, fax, email or write to:

**Scott Health & Safety**

**4320 Goldmine Road**

**Monroe, NC 28110**

Website: [www.scotthealthsafety.com](http://www.scotthealthsafety.com)

Phone: 800.247.7257

FAX 704.291.8330

#### 1.4. Acronyms Quick Reference

Throughout the duration of this manual, several acronyms are used. Provided in [Table 1-1](#) is a quick reference chart to quickly identify any acronym that may be unfamiliar to users.

Table 1-1. Acronym Quick Reference List

Acronym	Definition
AC	Alternating Current
DC	Direct Current
FAT	File Allocation Table
lb	Pounds
LCD	Liquid Crystal Display
LED	Light Emitting Diode
mm	Millimeter
PC	Personal Computer
psi	Pounds per Square inch
SD	Secure Digital
USB	Universal Serial Bus

This Page Left Intentionally Blank

## **2. Introduction**

---

The Masterdock is an automated bump testing and calibration station designed exclusively for performing bump tests and calibration of Scott's Protégé portable gas monitors. The Masterdock allows users to quickly and effectively verify the proper operation of the Protégé with the touch of a button. Removable memory in the Masterdock logs all calibrations and testing for accurate record keeping. The Masterdock can be powered using the included AC adapter or by installing four alkaline C-cell batteries.

The Masterdock eliminates the need to connect a calibration adapter and a remote calibration cylinder to the Protégé. A calibration cylinder is installed into the docking station allowing for multiple bump tests and calibrations of Protégé units simply by docking a Protégé into the Masterdock and pressing a button.

The Masterdock can be used on any flat surface such as a desk top, or can be mounted on a wall. Wall-mounting instructions are included in this guide.

Refer to Figure 2-1.

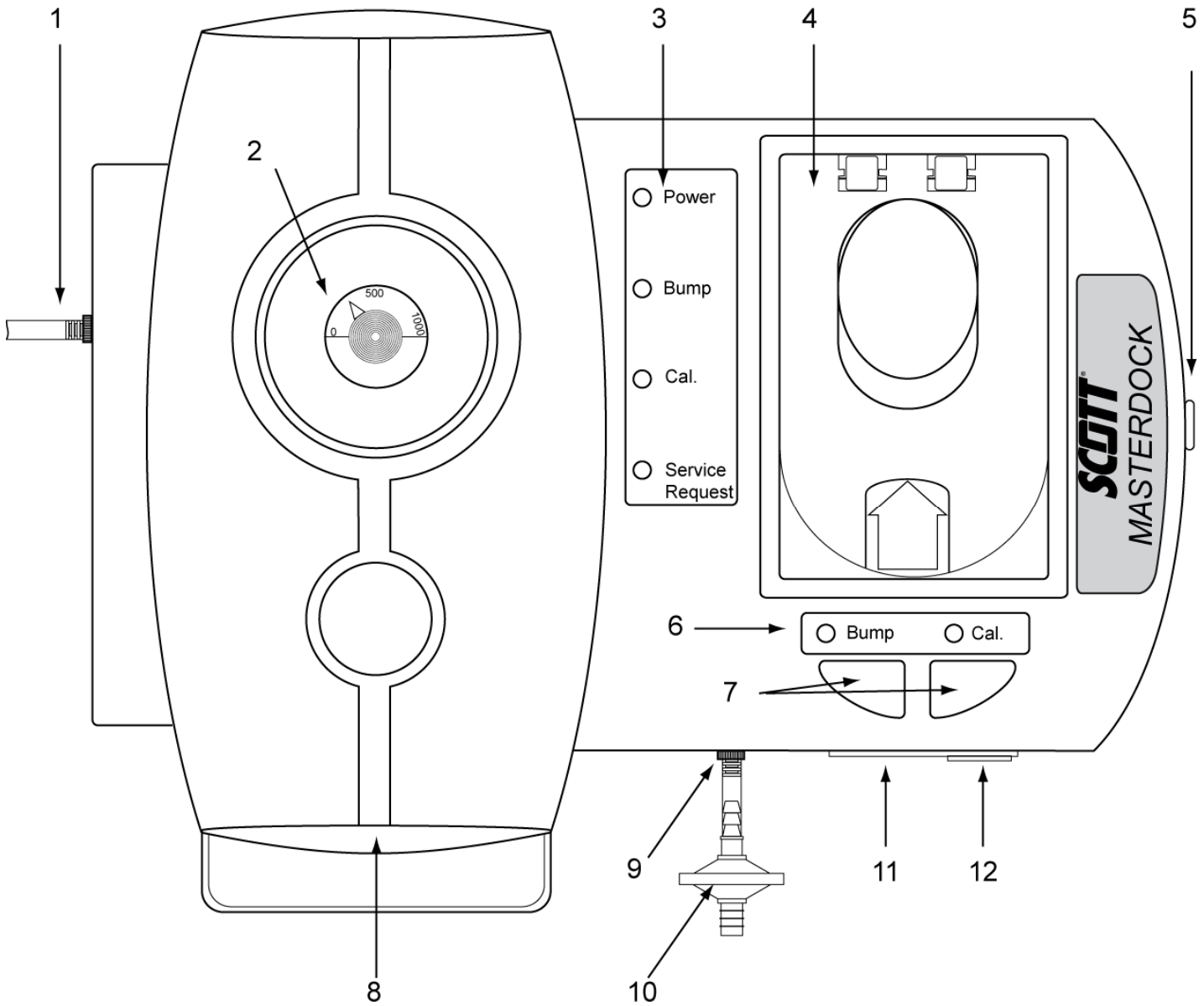

Figure 2-1. Masterdock Components

Table 2-1. Masterdock Components

Number	Component	Number	Component
1	Air Outlet	7	Bump and Calibration Activation Buttons
2	Calibration Gas Gauge	8	Calibration Gas Dock
3	Status LEDs	9	Air Inlet
4	Protégé Dock	10	Air Filter
5	Battery Cover (On Side of Unit)	11	USB Port
6	Activation LEDs	12	SD Card Slot



### 3. Setup and Mounting

#### 3.1. Mounting the Masterdock

The Masterdock does not need to be mounted on a wall to operate. It may be placed on any desk top, table top, or other horizontal surface and will operate. However, users may choose a more permanent location, such as mounted on a wall.

To mount the Masterdock on the wall, drill four holes per the dimensions shown in Figure 3-1. Mounting hardware must not exceed 14.5 mm in diameter and be capable of supporting the weight of the Masterdock.

**NOTE**

*THE MASTERDOCK WEIGHS APPROXIMATELY 8.5 LBS WITHOUT A CYLINDER OR PROTÉGÉ DOCKED.*

Allow for sufficient spacing around the Masterdock to utilize all the features such as installing calibration cylinders and accessing the battery compartment.

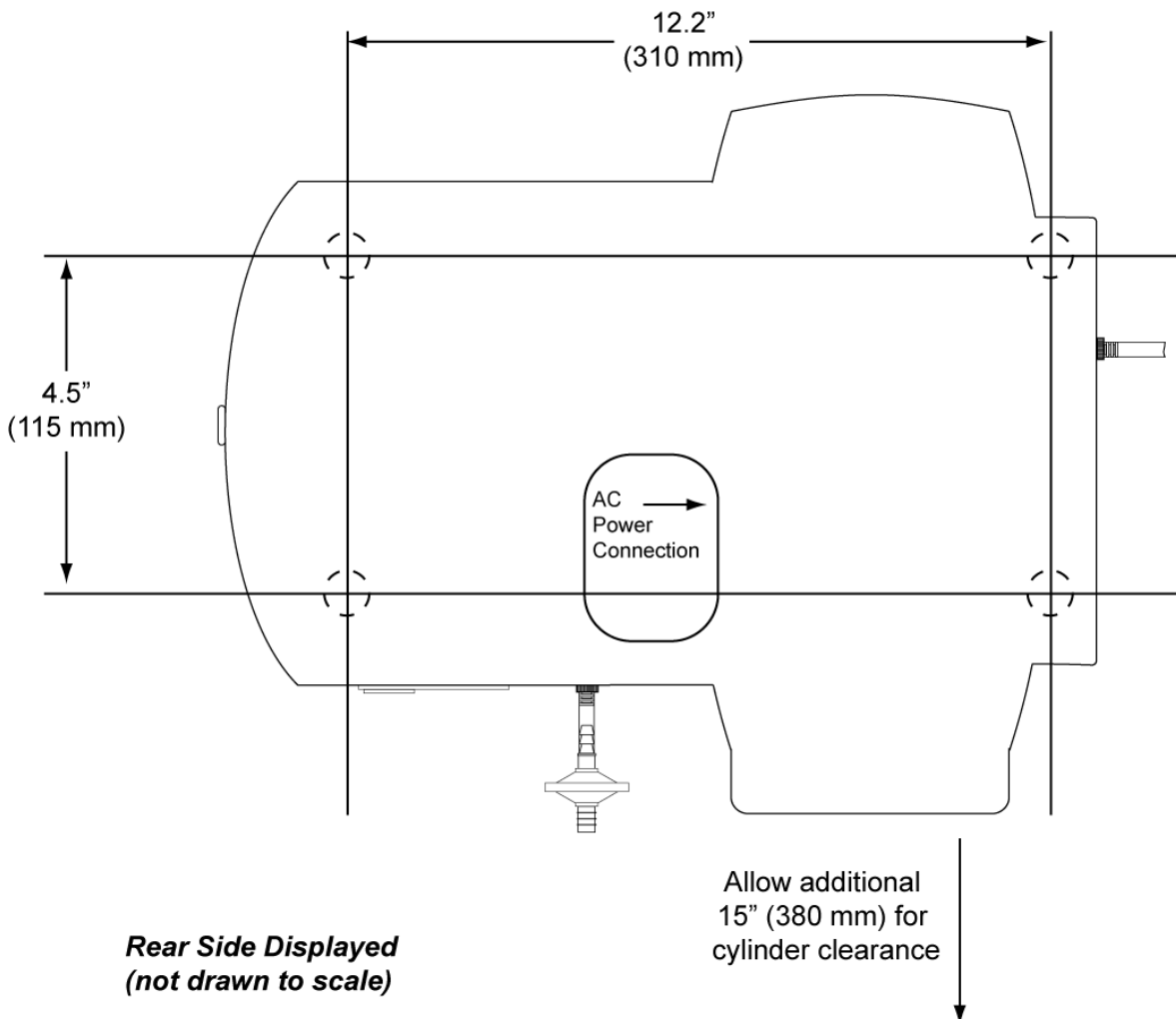

Figure 3-1. Masterdock Wall Mounting Dimensions

**3.2. Powering the Masterdock**

The master dock must be powered from an external power supply plugged into the rear side receptacle or with 4 C-cell batteries. External power supplies may be plugged into the wall or to a 12V cigarette lighter socket.

Refer to Figure 3-1 for the location of the AC power connection.

The battery compartment is located on the side of the Masterdock. Push up on the tab and then pull up on the door to remove the cover. Rechargeable batteries may be used; however, the Masterdock will not recharge those batteries when connected to an external source. Rechargeable batteries must be removed and charged in an external charger.

**3.3. Connecting Calibration Gas**

Insert either 58L or 34L cylinder of calibration gas into the Calibration Gas Dock and thread into place.

**NOTE**

*IF USING THE 58L CYLINDER, THE RUBBER SLEEVE MUST BE REMOVED FROM THE CALIBRATION GAS DOCK.*

The Gas Gauge will indicate cylinder pressure. Cylinder pressure must be above 50 PSI to perform a calibration or bump test. There is no isolation valve. The Masterdock controls flow automatically through a solenoid valve.

The cylinder does not need to be removed between bump tests or calibrations. When cylinder contents fall below 50 psi, remove from dock simply by unthreading the cylinder.

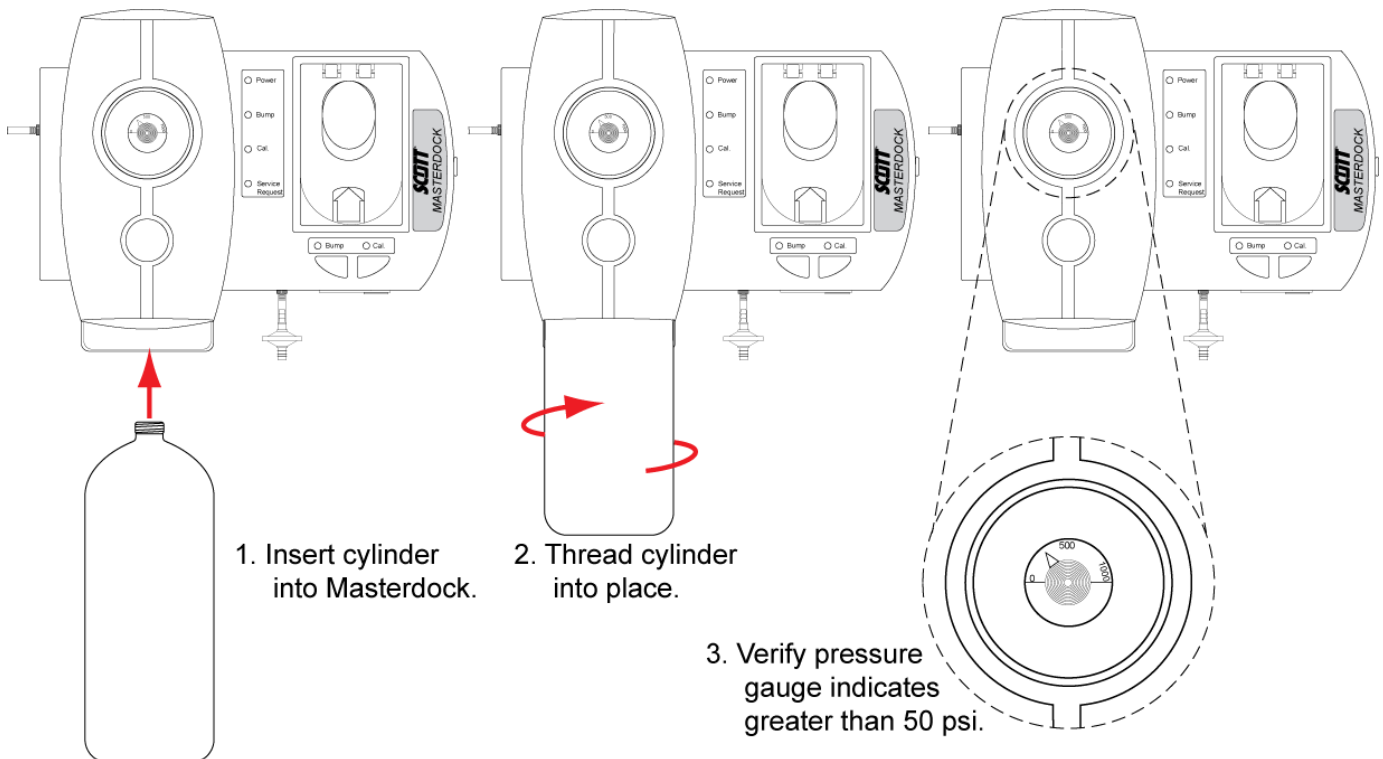

Figure 3-2. Installing Calibration Gas

### 3.4. Secure Digital Memory Card

The Masterdock docking station comes with an SD memory card for electronic storage of all bump tests and calibrations for transferring of data to a PC. The Masterdock will not perform a bump test or calibration with out the SD card installed and sufficient memory available. Do not use the SD card for saving any other file types or data.

To install the SD card, open the cover found on the bottom of the Masterdock next to the USB connection. Verify the SD card is unlocked prior to installation. Slide the SD card into the slot fully until it clicks and close the cover.

To remove the SD card, push the card in and allow it to release, then pull the card out.

Keep the SD port cover closed at all times when not removing or installing an SD card. This will prevent dust and contaminants out of the data drive.

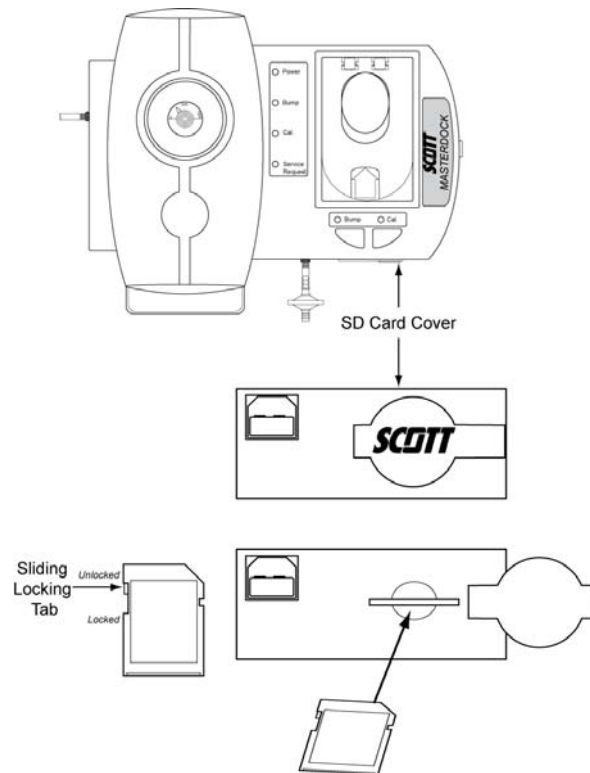

Figure 3-3. Installing SD Memory Card

The SD memory card that comes with the Masterdock has been formatted for use. New SD cards will need to be formatted prior to use with the Masterdock. Replacement SD cards must not exceed 2GB.

#### **NOTE**

***CUSTOMERS MUST SUPPLY AN EXTERNAL SD MEDIA CARD READER TO ACCESS THE DATA ON THE CARD. SCOTT HEALTH & SAFETY DOES NOT SUPPLY A READER.***

Each record contains roughly 200 bytes of data allowing a 2GB memory card to hold thousands of records.

### **3.4.1. Formatting an SD Card**

If the Service Requested LED blinks orange on the Masterdock or if you are using a new SD card for the first time, the SD card may need to be formatted. The Masterdock does not automatically format a card, it must be formatted using a PC.

SD cards typically come formatted by the manufacturer, but for an SD card to operate properly in the Masterdock, it must be formatted for FAT32, a 32-bit file allocation system. If the card is formatted for FAT or FAT16 or unformatted, it must be formatted for FAT32.

Before using an SD card or checking whether it needs formatting, verify the sliding locking tab is in the unlocked position as shown in Figure 3-3.

#### **NOTE**

***FORMATTING AN SD MEMORY CARD WILL ERASE ALL DATA ON THE CARD. BACKUP ANY DATA PRIOR TO FORMATTING.***

Verify the lock tab on the memory card is unlocked and connect the SD memory card to a PC. Open the My Computer icon on the desk top. Locate the SD card, it is typically identified as Removable Disk. Right click and select Format. When the Format Disk window appears, set or verify the File System is set to FAT32 and select Start. The PC will notify when the format is complete.

### **3.5. Air Filter**

Verify the Air Inlet port on the bottom of the Masterdock is not operated without the filter in place. The filter prevents dust and other contaminants from entering the Masterdock unit.

#### **CAUTION**

***OPERATING THE MASTERDOCK WITHOUT THE AIR FILTER IN PLACE MAY CAUSE CALIBRATIONS OR BUMP TESTS TO FAIL.***

Periodically inspect and replace the air filter as necessary.

### **3.6. Installing Software**

The Masterdock Utility software comes on the CD packaged with the docking station. The utility is used to upgrade firmware, set the date and time and to input calibration gas lot numbers for data recording.

Installation of the software onto a PC occurs in two stages. First a driver must be loaded for the USB, then the utility program is installed.

Insert the CD into a PC. Once the start-up screen appears click on the appropriate buttons and follow the on-screen prompts.

## 4. Operation

### 4.1. Bump Testing and Calibration

Prior to performing any bump test or calibration, the Protégé unit and the Masterdock must be powered on. Verify the Battery LED is green on the Masterdock and the pressure gauge indicates greater than 50 psi. Ensure the air inlet is not obstructed and the filter is clean.

- 1) Open the door to the docking station and insert the powered on Protégé unit face down so that that charging contacts of the Protégé align with contacts in the docking station door.
- 2) Close the door to the docking station.
- 3) Verify the Bump and Cal. LEDs are lit green. If not, open door and verify the Protégé is firmly seated in docking station.
- 4) Push Bump to perform a bump test or Cal. to perform a calibration. The LED above the selected button will turn off and the status LED will begin blinking orange.
- 5) When the status LED lights green, the Protégé unit has completed testing. If the LED lights red instead of green, the test has failed.

### 4.2. LED Alerts and Displays

Refer to Table 4-1 for Status LED indications and their meanings.

Table 4-1. Status LED Indications

Status LED	Red	Green	Orange (Blinking)
<b>Power</b>	Low Battery, external power not supplied	Battery power or external power is sufficient	N/A
<b>Bump</b>	Test Failed	Test Passed	Test in Progress
<b>Cal.</b>	Test Failed	Test Passed	Test in Progress
<b>Service Request</b>	SD card is not installed <b>OR</b> SD card memory is full <b>OR</b> a communication failure has occurred <b>OR</b> The date/time needs synchronization with the Masterdock Utility	N/A	SD card is locked <b>OR</b> SD cards needs formatting <b>OR</b> SD memory is low <b>OR</b> synchronize the date/time using the Masterdock Utility

### 4.3. Masterdock Utility

#### 4.3.1. Connecting Masterdock to a PC

- 1) Use the supplied USB cable to connect the Masterdock to a PC.
- 2) Right click on the My Computer icon found on the desktop and select properties.
- 3) Select the Hardware Tab.
- 4) Select Device Manager.
- 5) Click on the + icon to the left of Ports. Identify the COM number associated CP210x to UART Bridge Controller. This COM port number is necessary for configuring the Masterdock Utility.
- 6) Open the Masterdock Utility software.
- 7) Select Operation -> Setup Port. Select the COM number previously identified.

#### 4.3.2. Masterdock Utility Modes

The Masterdock utility can be used in User Mode or Administrator Mode. All options available in User Mode are available in Administrator Mode. However, Administrator Mode also allows users to set the Gas Lot Number, set the Location, synchronize the Masterdock to the time on the PC, and configure the Masterdock to perform a calibration in the event of a bump test failure.

The Administrator mode is password protected. To select Administrator Mode, Select Operation -> Operation Mode -> Administrator Mode. At the password prompt screen, a Change Password option is available.

### **NOTE**

***THE DEFAULT PASSWORD FOR THE ADMINISTRATOR MODE IS SCOTT (ALL CAPITAL LETTERS).***

### 4.3.3. Masterdock Utility Main Display

The Masterdock Utility Main Display shows Firmware Revision, the date and time, Gas Lot Number, Serial Number, and Location of the Masterdock. When in Administrator Mode, the options to sync time with the PC clock and Calibrate if a Bump test fails become available.

A toolbar located at the top of the display has three quick use buttons; Get Configurations, Upgrade Firmware, and Help.

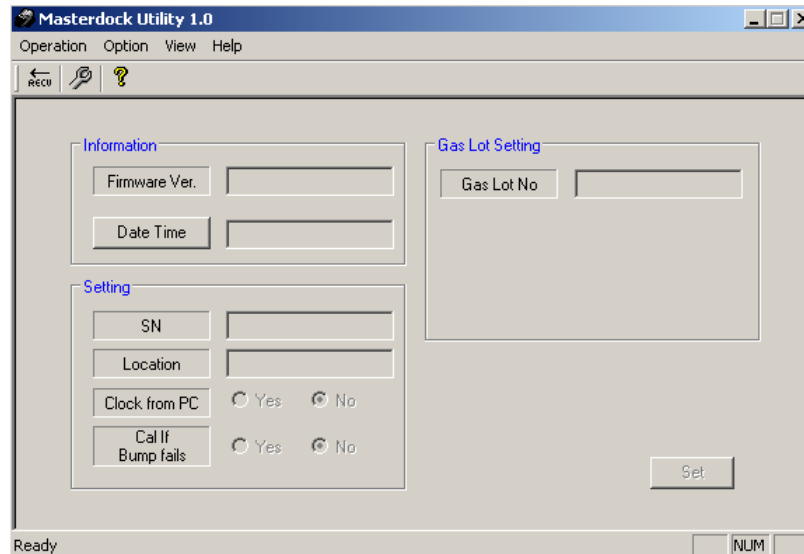

Figure 4-1. Masterdock Utility Main Display

### 4.3.4. Masterdock Utility Menus

Four Menus are available for use in the Masterdock, Operation, Option, View, and Help. Not all selections will be available depending on which mode is selected.

#### 4.3.4.1. Operation Menu

**Setup Port** - Used to change the COM port. Refer to Paragraph 4.3.1 for more information.

**Get Configurations** - Used to poll the Masterdock about current information for display including the Firmware Revision, Gas Lot Number, Serial Number, and Location of the Masterdock.

**Operation Mode** - Used to select either user mode or Administrator Mode. Refer to Paragraph 4.3.2. for more information.

**Upgrade Firmware** - Used to Upgrade the Firmware installed in the Masterdock.

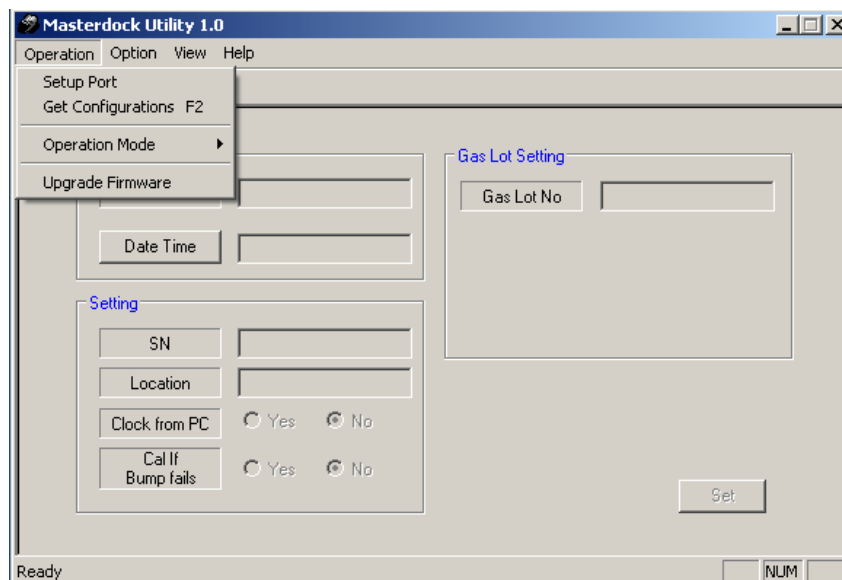

Figure 4-2. Masterdock Utility Operation Menu



#### 4.3.4.2. Option Menu

**Language** - Used to Select which language for the Masterdock utility to display.

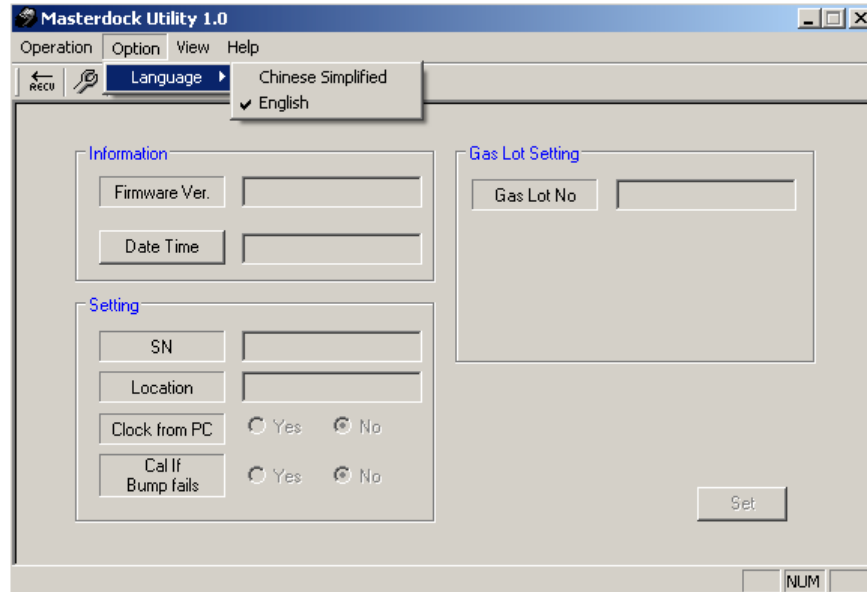

Figure 4-3. Masterdock Utility Option Menu

#### 4.3.4.3. View Menu

**Toolbar** - Used to display or hide the Toolbar.

**Status Bar** - Used to display or hide the Status Bar.

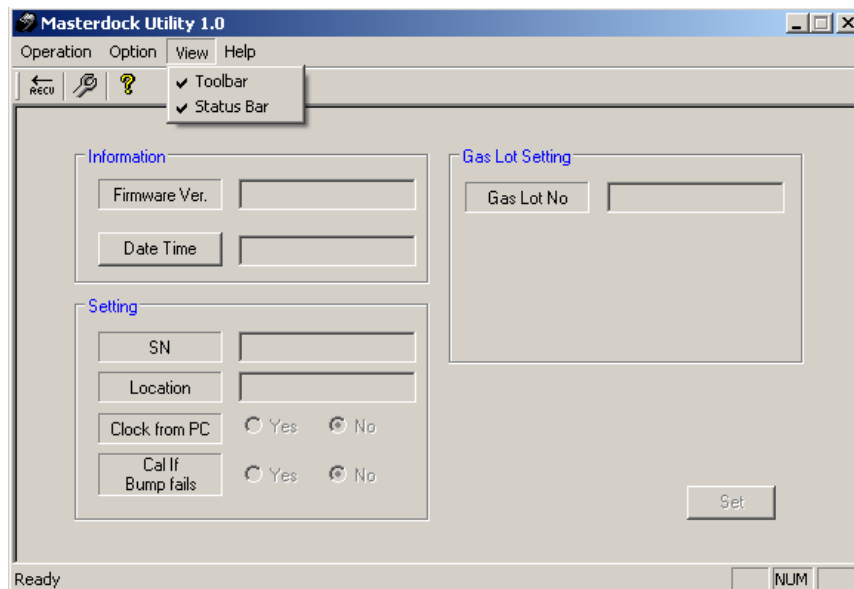

Figure 4-4. Masterdock Utility View Menu

#### 4.3.4.4. Help Menu

**About Masterdock Utility** - Used to display the current software revision level of the Masterdock Utility.

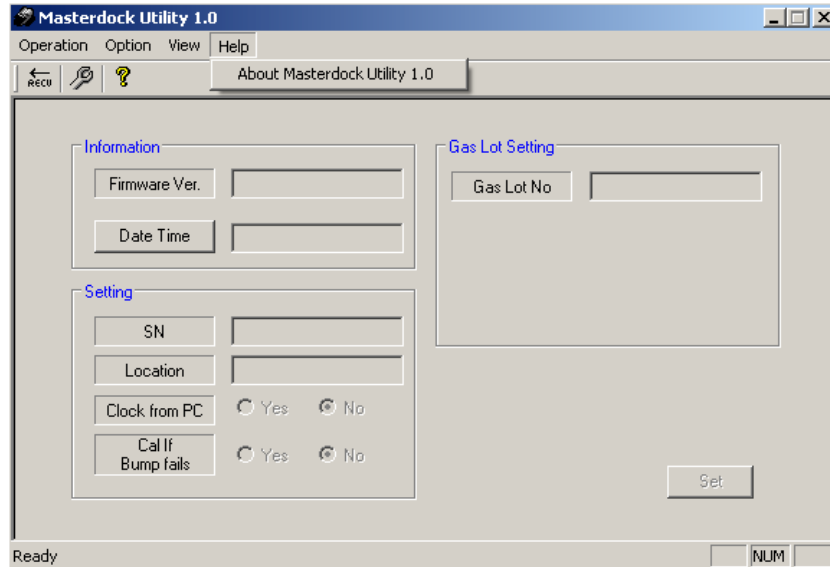

Figure 4-5. Masterdock Utility Help menu

## 5. Parts List and Maintenance

Table 5-1. Parts List

Part Description	Scott P/N
Masterdock	093-0526
Instruction Manual	087-0045
Scott Portable gas Detection CD (Masterdock Software and Instruction Manual Included)	096-3366
Quick Start Guide	062-0031
USB Cable	093-0527
12V Power Supply	028-0053
SD Memory Card	093-0532
Air Filter (5 pack)	093-0534
Cigarette Cable Supply	028-0054
Calibration Gas 34L	077-0351
Calibration Gas 58L	077-0352

### 5.1. Cleaning and Routine Maintenance

The Masterdock is designed to be free of routine maintenance unless operated with batteries. As needed, replace batteries with C-Cell batteries. Rechargeable batteries may be used in the Masterdock, however batteries will not recharge when installed in the Masterdock. Batteries must be charged with an external charger.

### **CAUTION**

***NEVER LEAVE DEAD BATTERIES INSTALLED IN THE MASTERDOCK AS THEY MAY LEAK OR CORRODE AND CAUSE DAMAGE TO COMPONENTS.***

Clean the Masterdock as needed using only compressed air or a clean dry cloth. If needed, a dampened cloth may be used for external cleaning, however do not use any cleaners or solvents.

5.2. Troubleshooting

Table 5-2. Troubleshooting Chart

Indication	Reason	Recommended Action(s)
All LEDs extinguished	Masterdock is not receiving power	Verify power source. If battery operated, verify batteries have sufficient charge. If powered externally, verify power source is connected. Verify AC adapter is not damaged. Check for loose or broken wires.
Service Request LED is red, unable to perform a Bump Test or Calibration	SD Card problem <b>OR</b> Date/Time Synchronization is required	Verify SD card is installed. Connect SD card to PC and remove data to clear memory on card. Replace SD memory card. <b>OR</b> Synchronize the Masterdock date/time using the Masterdock Utility.
LEDs indicate normal operation (Green) however unable to perform a Bump Test or Calibration	Empty calibration cylinder <b>OR</b> Defective gauge <b>OR</b> Obstruction in inlet line	Replace cylinder. Verify gauge indicates properly with a full tank. Verify inlet line and air filter are clear of obstructions.
Pump does not operate	Faulty pump <b>OR</b> Obstructed line	Check pump wiring, clear obstructions from air inlet, air outlet and port inside docking station door to Protégé, or replace pump.
Masterdock Utility fails to open COM port	Port has not been setup <b>OR</b> USB driver has not been installed correctly	Refer to <a href="#">Paragraph 3.6</a> and <a href="#">Paragraph 4.3</a> .
Bump and Cal. LED flash red	Pump is stalled, Cal Gas bottle is empty	Replace Calibration Gas bottle. Refer to <a href="#">Paragraph 3.3</a> .

### **5.3. Scott Repairs**

For quick and effective service of your instrumentation, and to reduce time spent on repairs, the SCOTT Instruments Service Department requires a Return Maintenance Authorization number be issued prior to any product being shipped for service repairs.

Contact the Service Department at:

Phone: 1- 800-247-7257 • Fax: 1-704-291-8330

Monday - Friday

8.30 AM to 5.00 PM EST.

e-mail: [techsupport.scotths.us@tycoint.com](mailto:techsupport.scotths.us@tycoint.com)

[www.scotthealthsafety.com](http://www.scotthealthsafety.com)



Health & Safety  
Monroe Corporate Center  
PO Box 569  
Monroe, NC 28111  
Telephone 1-800-247-7257  
FAX (704) 291-8330  
[www.scotthealthsafety.com](http://www.scotthealthsafety.com)

Printed in the USA

Copyright © 2010, SCOTT, All Rights Reserved