

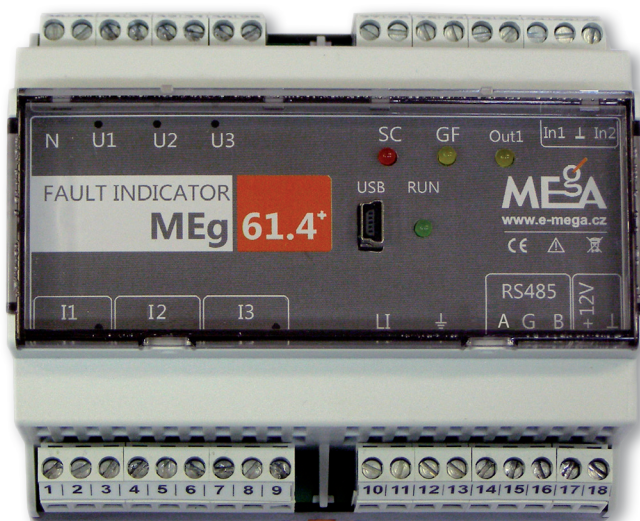

# Short-circuit and ground fault indicator MEg61.4<sup>+</sup>

User manual



**Měřicí Energetické Aparáty, a.s.**  
664 31 Česká 390  
Czech Republic





# Short-circuit and ground fault indicator

## MEg61.4<sup>+</sup>

### 1/ INTRODUCTION

The short-circuit and ground fault indicator MEg61.4<sup>+</sup> (hereinafter MEg61.4<sup>+</sup> indicator only) stems from well-proven functions of the previous ground fault indicators of MEg61.4 series which were supplemented with new recording functions. Thus one unit incorporates the ground fault indicator for MV levels where, except for identification of faults and registration of fault states, continuous monitoring and long-term recording of monitored quantities is performed as well.

The MEg61.4<sup>+</sup> indicator identifies the segment of overhead line in which a ground fault or a short-circuit (overcurrent) occurred. The MEg61.4<sup>+</sup> indicator can be used for outdoor installation on MV overhead line poles or for installation in internal environment with cable MV lines. Bolted, arc and low impedance ground faults and all types of short-circuits are indicated. It is primarily designed for use in compensated MV distribution networks; however, it can be used in MV distribution networks with grounded neutral.

The MEg61.4<sup>+</sup> indicator measures and records the data related to voltages, currents and powers in the non-destructive electronic memory in preselected intervals.

Ground fault records consist of the curves containing 10 ms values and the curves containing individual samples of basic quantities.

The MEg61.4<sup>+</sup> indicator has input circuits specially designed for connection of various measuring converters and sensors. The voltage can be connected from the measuring voltage transformer (MTN), from the capacitor or resistor dividers and from the electric field sensor. The current can be connected from the measuring current transformer (MTP), from the split-core current transformer (PTD), from the AMOS sensor (Rogowski coil) or from the magnetic field sensor.

The MEg61.4<sup>+</sup> indicator is provided with a possibility of connecting two input signals and one output signal. Types of ground connection and short-circuit faults are indicated by indicating lights on the instrument panel and with a free contact on the indicator ter-

minals. It is possible to connect an external light signalling and external signalling reset. It also includes the RS485 interface with MODBUS protocol.

A ground fault or a short circuit is signalled by interrupted light with the predefined activation time, by relay contact closing or on request by means of the MODBUS protocol command.

## 2/ TECHNICAL PARAMETERS

### Reference conditions

$U_{\text{supply}} = 12 V_{\text{DC}}$ , ambient temperature = 20 °C, relative humidity = 40 % to 70 %  
 $f = 50.0 \text{ Hz}$ , measured voltages and currents with identical frequency form a three-phase system.

### Basic parameters

Supply voltage:	$12 V_{\text{DC}}$
Supply current:	80 mA, $12 V_{\text{DC}}$ , 100 mA max.
Protection rating:	IP20
Operating temperature:	-25 °C to +60 °C
Relative humidity:	20 % to 90 % at 40 °C
Weight:	0.4 kg
Dimensions of the unit:	108 × 90 × 63 mm (length × width × height)
Installation:	DIN rail TC35 (35 × 7,5 mm) Installation case (160 × 120 × 90 mm)
Terminal block, max. wire diameter:	2.5 mm
Communication/connector:	USB/mini
RS485 (MODBUS), max. Baud rate:	115.2 kbit/s
Number or galvanically isolated outputs:	3 (SC, GF, Out1) maximum switched voltage: $30 V_{\text{AC}}$ , $30 V_{\text{DC}}$ maximum switched current: 30 mA
Number of inputs:	2 (dry contact)
Light activation time:	2 hrs (parametrizable)

Data memory:	4 MB + 4 MB (flash)
Data memory organization:	circulate memory
Recording interval:	from 1 sec to 15 minutes, set by software
Maximum number of recorded events:	1024
Maximum length of recorded event curve:	125 periods, 250 values $U_{\text{RMS1/2}}$
Fixed pre-trigger:	10 periods
Fixed post-trigger:	20 periods
Oscillogram:	64 samples/period
Oscillogram length:	selectable standard: 8 periods
Storage temperature:	-25 °C to +80 °C
Protection rating:	IP20 – accessible parts, IP00 – inaccessible parts
Pollution degree:	2

### **Electromagnetic compatibility**

ČSN EN 61326-1: 2006 Electrical equipment for measurement, control and laboratory use – EMC requirements Part 1: General requirements 31<sup>st</sup> December 2006.

(ČSN EN 61000-4-2, ČSN EN 61000-4-3, ČSN EN 61000-4-4, ČSN EN 61000-4-5, ČSN EN 61000-4-6, ČSN EN 61000-4-9, ČSN EN 61000-4-11)

ČSN EN 55011 ed. 3:2010 Industrial, scientific and medical equipment – Radio-frequency disturbance characteristics – Limits and methods of measurement.

## Voltage inputs

### 1. Transformer

Rated value $U_{nom}$ :	$100/\sqrt{3} V_{AC}$
Maximum measured value:	$120 V_{AC}$
Measuring accuracy:	better than 0.5 % $U_{nom}$
Maximum value:	$150 V_{AC}$

### 2. Resistor network

Rated value $U_{nom}$ :	$100/\sqrt{3} V_{AC}$
Maximum measured value:	$120 V_{AC}$
Measuring accuracy:	better than 0.5 % $U_{nom}$
Maximum value:	$150 V_{AC}$
Input impedance:	$> 1 M\Omega$

### 3. Resistor divider 22 kV

Rated value $U_{nom}$ :	$2.4 V_{AC}$
Maximum measured value:	$208 \% U_{nom}$
Measuring accuracy:	better than 0.5 % $U_{nom}$
Maximum value:	$260 \% U_{nom}$

### 4. Resistor divider 35 kV

Rated value $U_{nom}$ :	$2.4 V_{AC}$
Maximum measured value:	$208 \% U_{nom}$
Measuring accuracy:	better than 0.5 % $U_{nom}$
Maximum value:	$260 \% U_{nom}$

### 5. Capacitor divider

Capacitor divider range:	8 pF – 150 pF
Number of internal amplification stages:	8
Rated level of MV network:	22 kV, 35 kV

### 6. Electric field sensor

Sensor location:	under the wire
Number of internal amplification stages:	8
Rated level of MV network:	22 kV, 35 kV

## Current inputs

### 1. Transformer 1 A

Rated value $I_{nom}$ :	$1 A_{AC}$
Measuring range, basic range:	2 % to 120 % $I_{nom}$
Measuring range, high range:	120 % to 2000 % $I_{nom}$
Measuring accuracy, basic range:	0.5 % $I_{nom}$ + 0.1 % of measured value
Measuring accuracy, high range:	10 % of measured value

### 2. Transformer 5 A

Rated value $I_{nom}$ :	$5 A_{AC}$
Measuring range, basic range:	2 % to 120 % $I_{nom}$
Measuring range, high range:	120 % to 2000 % $I_{nom}$
Measuring accuracy, basic range:	0.5 % $I_{nom}$ + 0.1 % of measured value
Measuring accuracy, high range:	10 % of measured value

### 3. Input 20 mA

Rated value $I_{nom}$ :	$20 mA_{AC}$
Measuring range, basic range:	2 % to 120 % $I_{nom}$
Measuring range, high range:	120 % to 2000 % $I_{nom}$
Measuring accuracy, basic range:	0.5 % $I_{nom}$ + 0.1 % of measured value
Measuring accuracy, high range:	10 % of measured value

### 4. Rogowski sensor

Rated value $I_{nom}$ :	250 A, 500 A
Measuring range, basic range:	2 % to 120 % $I_{nom}$
Measuring range, high range:	120 % to 2000 % $I_{nom}$

### 5. Magnetic field sensor

Sensor location:	under the wire
Number of internal amplification stages:	4
Current sensing range:	up to 300 A
Rated level of MV network:	22 kV, 35 kV

### Active power

Rated value  $P_{nom}$ :

$$U_{nom} \cdot I_{nom}$$

Measuring range:

$$0.8 U_{nom} \leq U \leq 1.3 U_{nom}$$

$$0.02 I_{nom} \leq I \leq 1.2 I_{nom}$$

$$\cos \varphi \geq 0.5$$

### Reactive power

Rated value  $Q_{nom}$ :

$$U_{nom} \cdot I_{nom}$$

Measuring range:

$$0.8 U_{nom} \leq U \leq 1.3 U_{nom}$$

$$0.02 I_{nomM} \leq I \leq 1.2 I_{nomM}$$

$$\cos \varphi \leq 0.707$$

### Active energy

Measuring range:

$$0.8 U_{nom} \leq U \leq 1.3 U_{nom}$$

$$0.02 I_{nomM} \leq I \leq 1.2 I_{nomM}$$

$$\cos \varphi L \geq 0.5$$

$$\cos \varphi C \geq 0.8$$

### Voltage phenomena

Rated value:

$$U_{nom}$$

$U_{RMS1/2}$  measurement range:

$$0.05 U_{nom} \leq U \leq 1.3 U_{nom}$$

T measuring range:

$$0.02 \text{ s} < T \leq 60 \text{ s}$$

T measuring accuracy:

$$\pm 20 \text{ ms}$$

### Short-circuit currents $I_z$

Rated value  $I_{nomZ}$ :

$$20 \cdot I_{nom}$$

$I_z$  measuring range:

$$1.2 I_{nom} \text{ to } I_{nomZ}$$

$I_z$  measurement accuracy:

$$10 \% \text{ of measured value}$$

### Internal time

Accuracy:

1.0 sec / 24 hrs at ambient reference temperature

PLL (Phase Locked Loop) frequency range: 42.5 Hz to 57.5 Hz

Note: Measurement accuracies apply to the signal with fundamental frequency.

Overload capacity of current inputs:  $2 I_{nom} / 1 \text{ min}$ ,  $10 I_{nom} / 1.5 \text{ sec}$



### 3/ CONSTRUCTION, WIRING AND DESCRIPTION OF THE PANEL

The MEg61.4<sup>+</sup> indicator is installed in a polycarbonate self-extinguishing case with the dimensions of 108 × 90 × 63 mm designed for DIN rail mounting. The transparent panel of the device can be sealed.

It is possible to deliver the MEg61.4<sup>+</sup> indicator for installation also in the plastic EURONORD case with overall dimensions 160 × 120 × 90, transparent plastic top cover and cable grommets for connection of measured and other signals. The supply voltage fuse is located in the cover case as well.

On the unit's panel, there is a green **RUN** LED light signalling the activity of the MEg61.4<sup>+</sup> indicator. The red LED signalling the occurrence of a short-circuit (**SC**), yellow LED signalling the occurrence of ground fault (**GF**) and another yellow LED signalling the state of output **Out1** or the occurrence of unsuccessful reclosure (**NOZ**).

The USB mini connector designed for local communication is located on the unit's panel.

Lead connections for measured voltages, currents, power supply, communication lines and others are carried out by screw terminals for wire cross-section up to 4 mm<sup>2</sup>. Measured voltages are brought to their relevant terminals **U1** (34), **U2** (32), **U3** (30), common terminals (33, 31, 29) or possibly to **N** (35, 36).

Measured currents are brought to triplets of terminals **I1** (1, 2, 3), **I2** (4, 5, 6) and **I3** (7, 8, 9) whereas the input current terminal is marked with a dot. The black wires of the magnetic field sensor are connected to terminals **I1** (2), **I2** (5) and **I3** (8). For a different type of current sensor, the terminals **I1** (2), **I2** (5) and **I3** (8) will remain unconnected and the input current will make use of terminals **I1** (1, 3), **I2** (4, 6) and **I3** (7, 9).

The supply voltage is connected to terminals **+12V** (17) and  $\perp$  (18).

Terminals **IN** (19, 21) are used for connection of the two-valued input signal against the terminal  $\perp$  (20); terminals 19 and 21 are positive. The output signal **SC** (26, 27), **GF** (24, 25), **Out1** (22, 23) is implemented by a relay contact.

For remote communication, the RS485 interface at terminals 14, 15 and 16 is used.

The external light signalling is connected to terminal **LI** (10). The external light signalling is fed from +12 V with the other pole.

Fig. 1: MEG61.4+ basic indicator unit dimensions

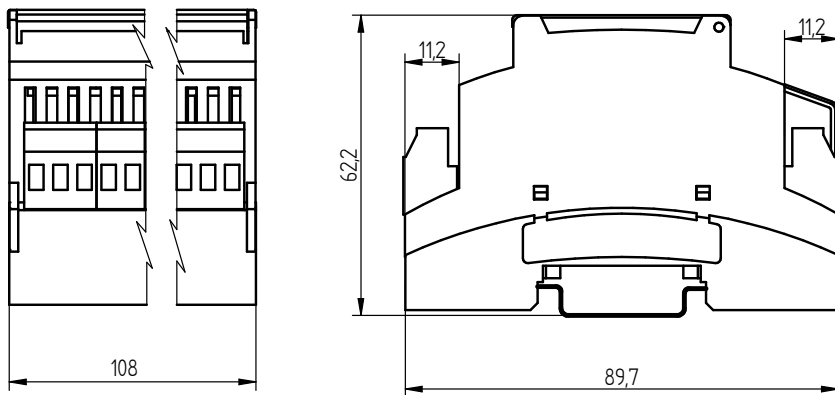
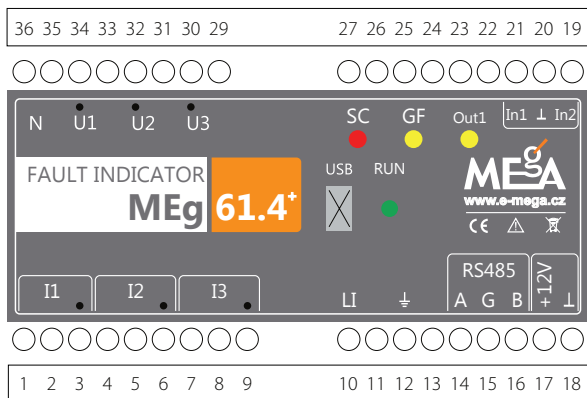

Fig. 2: MEG61.4+ indicator rating plate



Tab.1: Description of MEg61.4<sup>+</sup> indicator terminals

Terminal number	Terminal indication	Denotation
1	I1	I1 current input (MTI, PTD, AMOS, white sensor wire)
2		I1 current input (black sensor wire)
3		I1 current input (MTI, PTD, AMOS, red sensor wire)
4	I2	I2 current input (MTI, PTD, AMOS, white sensor wire)
5		I2 current input (black sensor wire)
6		I2 current input (MTI, PTD, AMOS, red sensor wire)
7	I3	I3 current input (MTI, PTD, AMOS, white sensor wire)
8		I3 current input (black sensor wire)
9		I3 current input (MTI, PTD, AMOS, red sensor wire)
10	LI	Output for external light signalling
11		
12	$\perp$	Common grounding
13		
14	A	<sup>1)</sup> RS485 signal A
15	G	<sup>1)</sup> RS485 ground
16	B	<sup>1)</sup> RS485 signal B
17	+12V	Supply voltage +12V
18	$\perp$	Supply voltage ground
19	In2	Signal input 2
20	$\perp$	Ground for inputs, common with power supply ground
21	In1	Signal input 1
22	Out1	Free relay contact out1
23		
24	GF	Free relay contact for ground fault
25		
26	SC	Free relay contact for short-circuit
27		

Terminal number	Terminal indication	Denotation
29	U3	U3 voltage input
30		U3 voltage input, active signal
31	U2	U2 voltage input
32		U2 voltage input, active signal
33	U1	U1 voltage input
34		U1 voltage input, active signal
35	N	Common point for input voltages
36		

<sup>1)</sup>RS485 interface is galvanically isolated

Tab.2: Types of voltage and current inputs

Input	Number code	Denotation	Comments
Voltage inputs	1	Transformer, $U_{nom} = 57,735 V$	MTN
	2	Resistor network, $U_{nom} = 57,735 V$	MTN
	3	Resistor divider, 22 kV	
	4	Resistor divider, 35 kV	
	5	Capacitor divider	
	6	Electric field sensor	
Current inputs	1	Transformer, $I_{nom} = 1 A$	MTP
	2	Transformer, $I_{nom} = 5 A$	MTP
	3	Input 20 mA	PTD
	4	Rogowski sensor	AMOSm
	5	Magnetic field sensor	

PTD: 100 A, 200 A, 300 A, 400 A, 500 A, 600 A

Rogowski sensor AMOSm: 250 A, 500 A

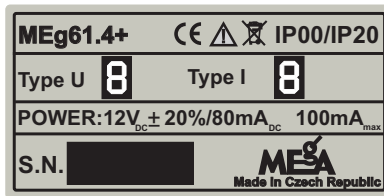
Fig. 3: MEg61.4<sup>+</sup> indicator rating plate

### Connection of input voltages and currents

The MEg61.4<sup>+</sup> indicator is set by the manufacturer for connection of input voltages and currents from the sensors indicated in Table 2. The type of input is marked with a number code. This number code is indicated on the rating plate of the MEg61.4<sup>+</sup> indicator and is stored in the indicator's internal memory as well.

A shielded cable is used for connection of the input voltages from the resistor and capacitor dividers and from the electric field sensor.

### Connection of input voltages

Fig. 4: Connection of input voltages from MTN – type 1

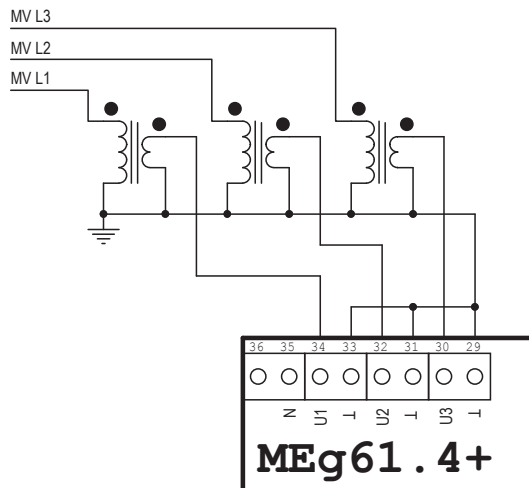

Fig. 5: Connection of input voltages from MTN – type 2

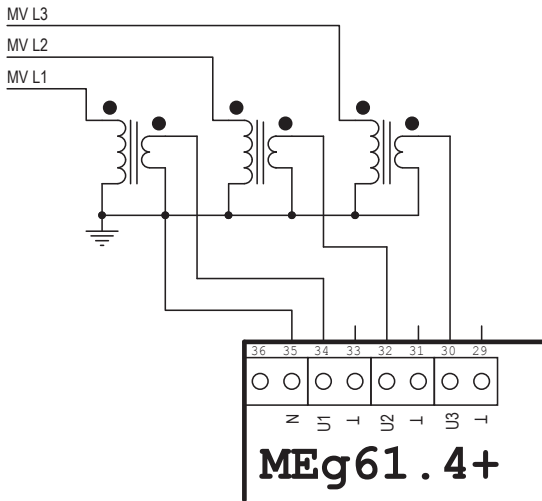

Fig. 6: Connection of input voltages from resistor divider – type 3,4

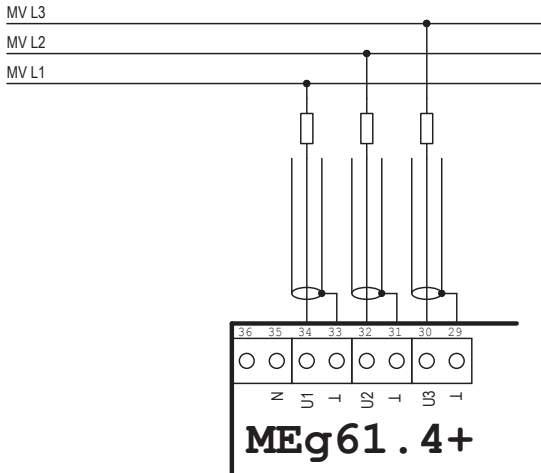

Fig. 7: Connection of input voltages from capacitor divider – type 5

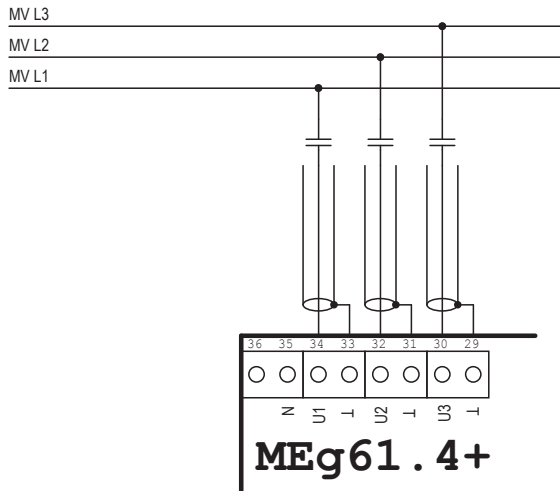
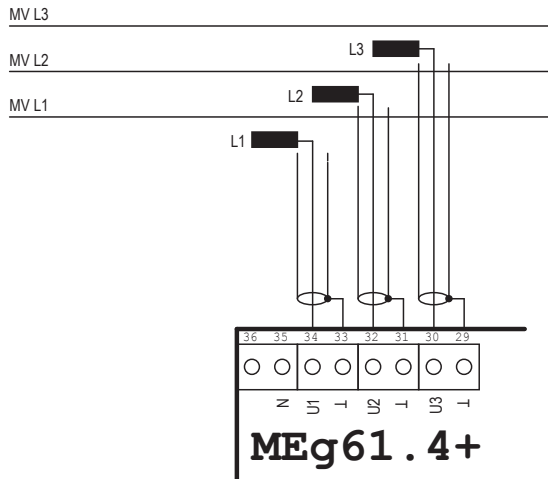

Fig. 8: Connection of input voltages from electric field sensor – type 6



**Connection of input currents**

Fig. 9: Connection of input currents from MTP – type 1, 2

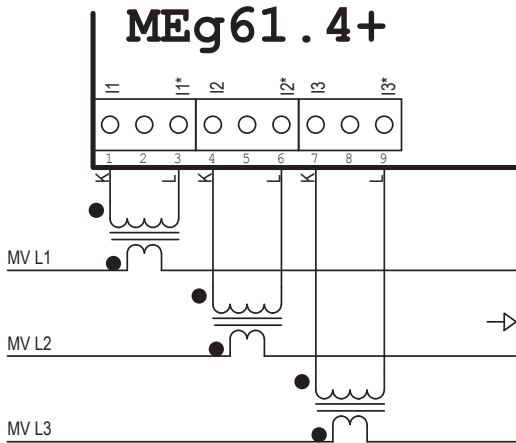

Fig. 10: Connection of input currents from PTD (20 mA) – type 3

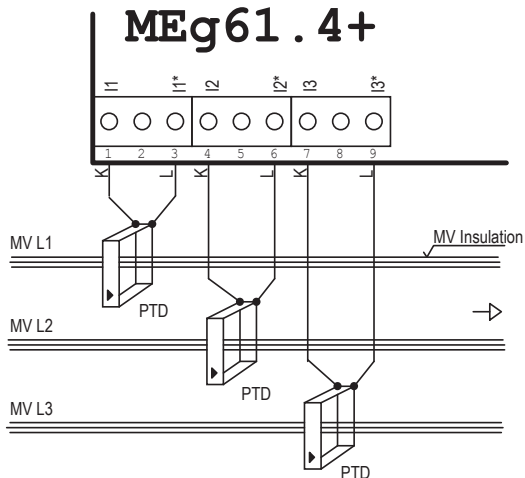



Fig. 11: Connection of input currents from AMOSm (Rogowski coil) – type 4

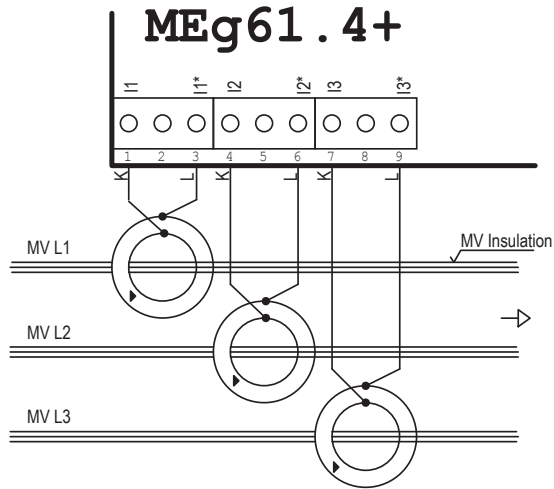
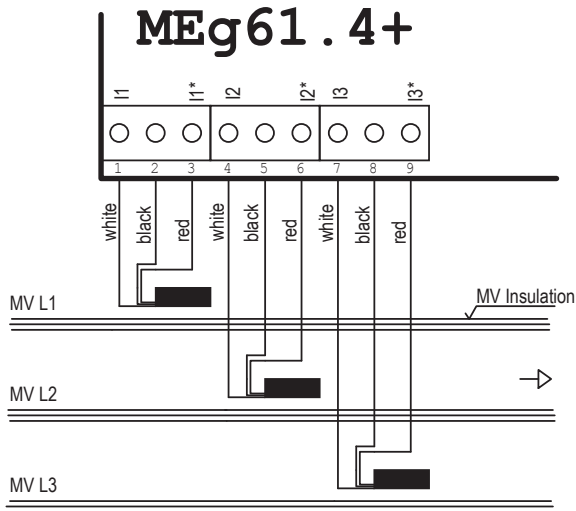

Fig. 12: Connection of input currents from magnetic field sensor – type 5



## Installation case

The basic MEG61.4<sup>+</sup> indicator unit can be delivered in the installation case with dimensions 160 × 120 × 90 mm. The installation case houses the OPVA10-1 fuse holder with 1 A fuse PVA10. In the lower part of the case there are grommets for insertion of cables. The case is provided with a transparent cover to enable monitoring of the states of the indicating elements.

In Figure 14, there is an example of wiring for voltage inputs from MTN and for current inputs from PTD. In Figure 15, there is an example of wiring for voltage inputs from capacitor dividers and for current inputs from PTD. Diagrams for individual voltage and current input connections are used for other types of sensing elements.

Fig. 13: Installation case dimensions

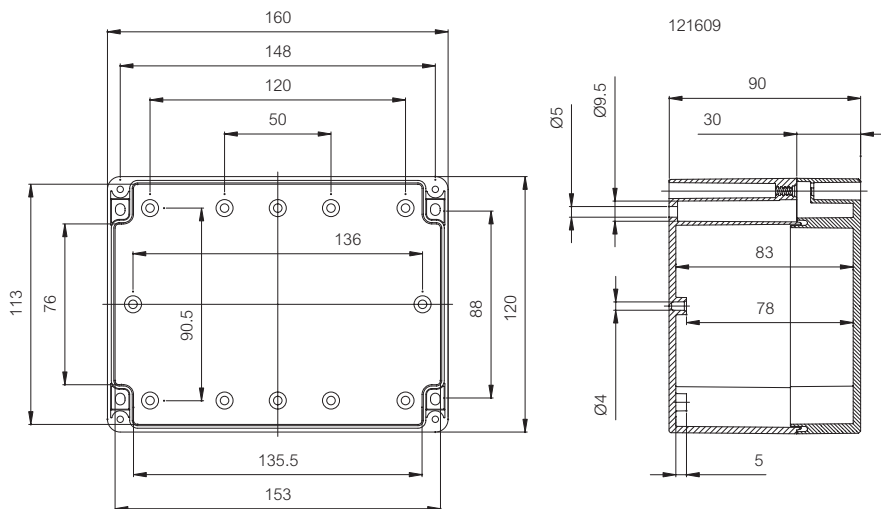

Fig. 14: Installation case wiring for input voltages from MTN and for input currents from PTD.

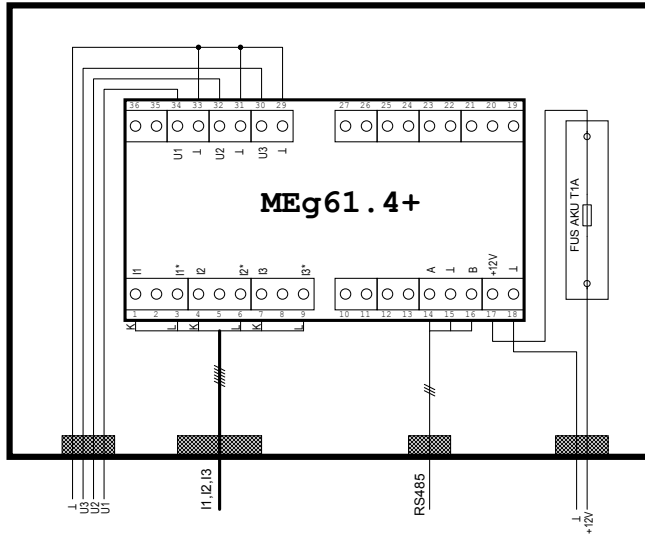
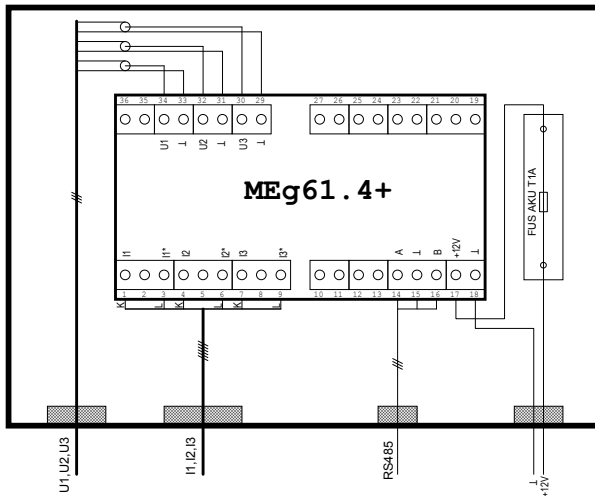

Fig. 15: Installation case wiring for input voltages from capacitor dividers and for input currents from PTD



## 4/ INSTALLATION PRINCIPLES

**Safety information.** Maximum attention must be paid to this information.



Warnings draw attention to the facts, constituting safety risks to the operator.



Cautions indicate conditions and facts that may cause damage to the MEG61.4\* indicator.

Explanation of symbols used in User Manual:



Danger, electric shock risk



Note in documentation / Danger, risk of danger



Ground, grounding terminal

IP code degree of protection provided by enclosure



The product is intended for recycling and collection spots.



Declaration of Conformity – European Community



### Warning

- **Be sure that the operator performing the installation must be equipped with and use personal protective equipment and other safety devices**
- **Warning: The installation of sensing elements at MV level is governed by special regulations, operating instructions and safety instructions not included in this manual.**
- **When using the MEG61.4<sup>+</sup> indicator in a way not intended by the manufacturer, the protection provided by the MEG61.4<sup>+</sup> indicator may be impaired.**
- **The MEG61.4<sup>+</sup> indicator is a Class A product designed for industrial environments. It may cause radio interference in other environments.**
- The operator installing and disassembling the MEG61.4<sup>+</sup> indicator must have qualifications for work near dangerous voltages. The operator must be trained in giving first aid.
- The MEG61.4<sup>+</sup> indicator may only be operated by qualified personnel equipped with personal protection equipment against electrical injury.
- It is not allowed to connect the indicator to voltages higher than 150 V<sub>AC</sub>, otherwise there is a risk of electrical injury.
- The MEG61.4<sup>+</sup> indicator may only be maintained and repaired by the manufacturer or service organizations trained by the manufacturer.
- It is not permitted to use other accessories than those included in the MEG61.4<sup>+</sup> indicator delivery.



### Caution

- The MEG61.4<sup>+</sup> indicator can be installed on the DIN rail by means of the plastic installation case with power supply fuse.
- The confusion of voltage and current types of MEG61.4<sup>+</sup> indicator inputs and sensing elements used may lead to indicator malfunction.
- Changing the type of voltage and current inputs can only be done by the manufacturer of MEG61.4<sup>+</sup> indicator.

### MEg61.4<sup>+</sup> indicator installation

The MEg61.4<sup>+</sup> indicator can be available for DIN rail installation or in plastic installation case. It is expected that the signals of already installed relevant sensors will be used.

1. Check the type of inputs for voltages and currents whether they correspond to sensing elements used.
2. Connect the three-phase voltage and current inputs. Bring the current terminals through additional short-circuiting terminal blocks. Use a shielded cable for voltage connections; use a two-core cable for current connections.
3. Connect +12V voltage with respect to correct polarity. For installation of the indicator in the installation case, connect the positive pole of the power supply to the terminal of the built-in fuse. Connect the power supply cables with the power supply switched off.
4. Use the communication cable to connect the MEg61.4<sup>+</sup> indicator with the master communication unit by means of RS485 line.
5. Connect other cables to the relevant terminals if appropriate. These are outputs of the relay contacts, input binary signals, resetting input and output to the external indication light.
6. Check the light of the green **RUN** LED after power supply is switched on.
7. Use the utility program to check if the output voltage and current are in phase. If not, use the short-circuiting current clamps and interchange the beginning and the end of the input current lines.
8. Use the utility program *MERCI* to set up necessary information for launching the indicator.

## 5/ INDICATION AND CONTROL

If the indicator is active, the green **RUN** LED is lit steadily. In the state of FW upgrade, the green LED flashes in a second interval.

For detecting the state of the indicator, its parametrization and reading out the current records the USB interface is used in collaboration with *MERCI* software.

For connecting to the remote communication, use the galvanically isolated serial interface RS485 with integrated MODBUS protocol.

The contacts of the **SC** relay are closed when a short-circuit (overcurrent) occurs. At the same time, the red **SC** LED starts flashing in a second interval. The LED is lit for a short time.

The contacts of the **GF** relay are closed when a ground fault occurs in the downstream direction of the indicator.

At the same time, the green **GF** LED starts flashing in a second interval. The LED is lit for a short time.

When SC and GF faults occur, the **LI** output controlling the external intensive light is released as well.

The states of indication can also be read out by means of the communication interface.

The states of indication can be cancelled after expiration of the set time (120 min as a standard) by sending a command by MODBUS protocol via the RS485 bus or using the user software.

If the indication is reset while the short-circuit is still present, the indication re-triggered immediately.

The USB or RS485 interfaces operate simultaneously. If the indicator is interconnected with the computer by means of the USB cable, the RS485 interface will not be blocked. To prevent from conflicts with remote control, it is necessary to disconnect the RS485 interface when local communication is requested.

The state at the **IN1**, **IN2** inputs can be transmitted remotely by the MODBUS protocol.

To evaluate the records use the *DataViewer-DVMEg* program.

## 6/ INDICATOR COMPONENTS

The MEg61.4<sup>+</sup> indicator incorporates these components:

- Basic unit
- Installation box with fuse and fuse holder

Sensing elements that can be connected to MV voltages and that provide the MEg61.4<sup>+</sup> indicator with input voltage and current quantities are described in separate manuals.

## 7/ MAINTENANCE REQUIREMENTS

Besides protection against dripping water and usual cleaning of the unit and its panel, the MEg61.4<sup>+</sup> indicator does not require any other maintenance. The MEg61.4<sup>+</sup> indicator has no rotary or moving parts.

## 8/ METHOD OF DELIVERY, HANDLING AND TRANSPORT

The place of delivery of the MEg61.4<sup>+</sup> indicator set if not specified otherwise, is the manufacturer's place of business. The components of the MEg61.4<sup>+</sup> indicator set are delivered in one box made of double-wall corrugated board. The boxes are recyclable. The other accessory components are provided in packages corresponding to their weights and mechanical dimensions.

Based on the specification in the purchase order, it is possible to send the MEg61.4<sup>+</sup> indicator with accessories by the transport service chosen by the customer.

Due to the weight of the individual wrapped parts up to 15 kg, no special measures are needed when handling the delivery.

Individual parts of the delivery are marked on their packages with the lists of components inside.



## 9/ ORDERING DATA

Basic:

- Quantity of short-circuit and ground fault indicators MEg61.4<sup>+</sup>
- Voltage level:
  - 22 kV level
  - 35 kV level
- Voltage input type
- Current input type:
  - Transformer:
    - 1 A
    - 5 A
  - PTD transformer with split core:
    - 100 A
    - 200 A
    - 400 A
    - 500 A
    - 600 A
  - Rogowski coil AMOS:
    - 250 A
    - 500 A

It is possible to deliver by special request:

- Plastic mounting case with grommets and circuit breaker.

The purchaser may place an order for training and calibration of the MEg61.4<sup>+</sup> indicator set with the manufacturer.

## 10/ WARRANTY

Two-year warranty is provided for the short circuit and ground fault indicator MEg61.4<sup>+</sup> and its accessories from its sale. Defects incurred during this period due to a provably defective construction, faulty workmanship or inappropriate materials will be repaired free of charge by the manufacturer and the place of performance is the seat of the manufacturer of the MEg61.4<sup>+</sup> indicator.

It is not permitted to open the MEg61.4<sup>+</sup> indicator unit during warranty period.

The warranty becomes invalid if the user carries out unauthorized modifications or changes on the MEg61.4<sup>+</sup> indicator or on its accessories if he connects the indicator incorrectly or if the indicator was operated contrary to technical conditions.

The defects on the MEg61.4<sup>+</sup> originating during the warranty period shall be claimed by the user to the manufacturer of the indicator. Claims without the warranty certificate enclosed will not be accepted.

The manufacturer bears in any case no responsibility for subsequent damages caused by using the MEg61.4<sup>+</sup> indicator. No responsibility which would exceed the price of the MEg61.4<sup>+</sup> indicator follows for the manufacturer from this warranty.

## 11/ MANUFACTURER

MEgA – Měřicí Energetické Aparáty, a.s.

664 31 Česká 390, Czech Republic

Tel. +420 545 214 988

e-mail: [mega@e-mega.cz](mailto:mega@e-mega.cz)

web: [www.e-mega.cz](http://www.e-mega.cz)





## Short-circuit and ground fault indicator MEg61.4<sup>+</sup>

User manual

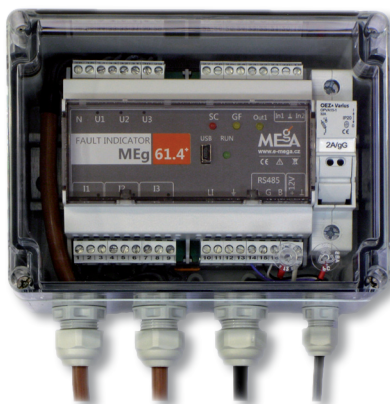

**Měřicí Energetické Aparáty, a.s.**

664 31 Česká 390

Czech Republic

[www.e-mega.cz](http://www.e-mega.cz)

Edition: 11/2014