



Orion BMS Thermistor Expansion Module

Product Manual

(document revision 2)



Revision A Model (metal case)



Revision B Model (plastic case)

Product Description:

The Orion BMS thermistor expansion module provides up to an additional 80 thermistor inputs (beyond the 4 that are supported by the main unit) for monitoring temperatures on large battery packs or situations where every cell temperature needs to be monitored. Up to 10 thermistor expansion modules can be used together with one BMS for a total of 804 thermistors.

Product Specifications:

- Operates with the Orion BMS from Ewert Energy Systems (BMS sold separately) or can be used as a standalone temperature monitoring device.
- Full automotive operating and sensing temperature range (-40C to 80C).
- High noise immunity.
- Communicates via CANBUS and can operate on several different CANBUS frequencies (125 Kbps, 250 Kbps, 500 Kbps, 1000 Kbps).
- Highest and lowest thermistor values are transmitted both via CANBUS and analog outputs.
- Can be configured to measure between 1 and 80 thermistors.

Installation & Wiring

All four thermistor connectors (the larger of the two different types of connectors) on the thermistor expansion module are identical in pin-out.

Connector Overview

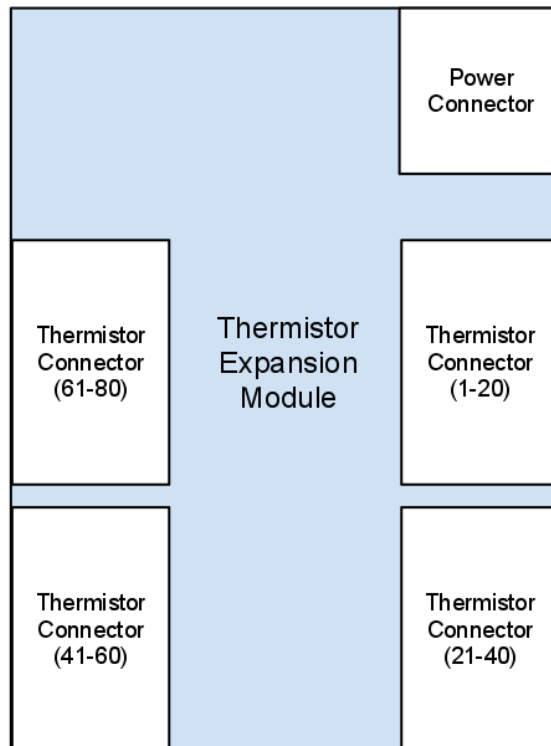

Thermistor Connector

Looking into back of connector (wires coming towards the viewer)

Therm GND	Therm 15	Therm 14	Therm 13	Therm 12	Therm 11	Therm GND	Therm 10	Therm 9	Therm 8	Therm 7	Therm 6
Therm GND	Therm 16	Therm 17	Therm 18	Therm 19	Therm 20	Therm GND	Therm 1	Therm 2	Therm 3	Therm 4	Therm 5

(pinout same for Rev A & Rev B)

Signal Name	Description
Therm X (Thermistor Input)	This is the input from a given thermistor and should register 0-5v depending on the temperature.
Therm GND (Thermistor Ground)	This is the ground side of a thermistor. In many cases there are several thermistor grounds tied together to reduce connector cost and board space.

Power Connector

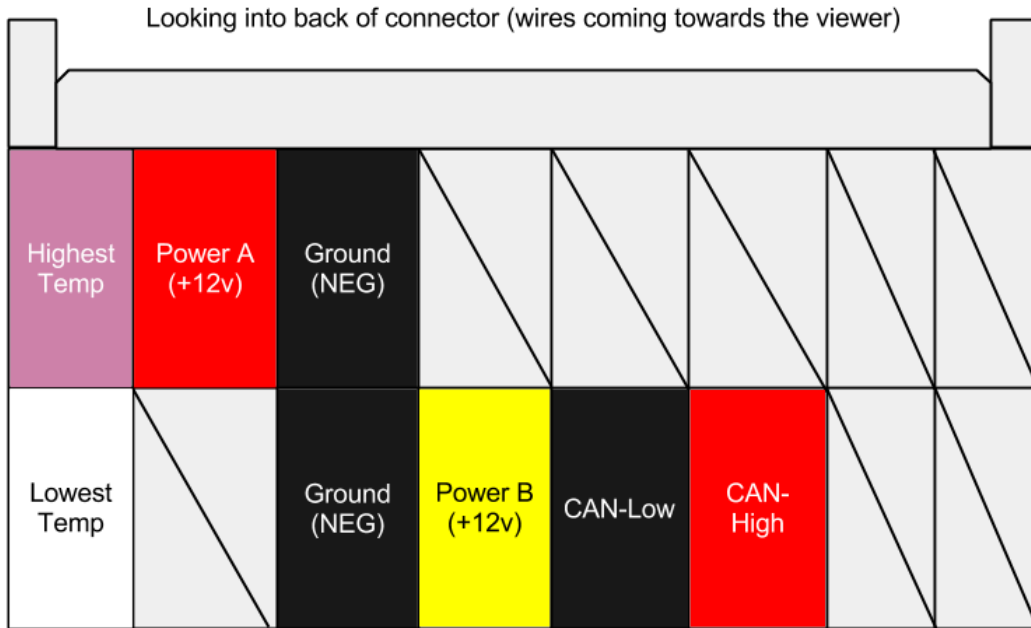

Revision A Power Connector (Metal Enclosure)

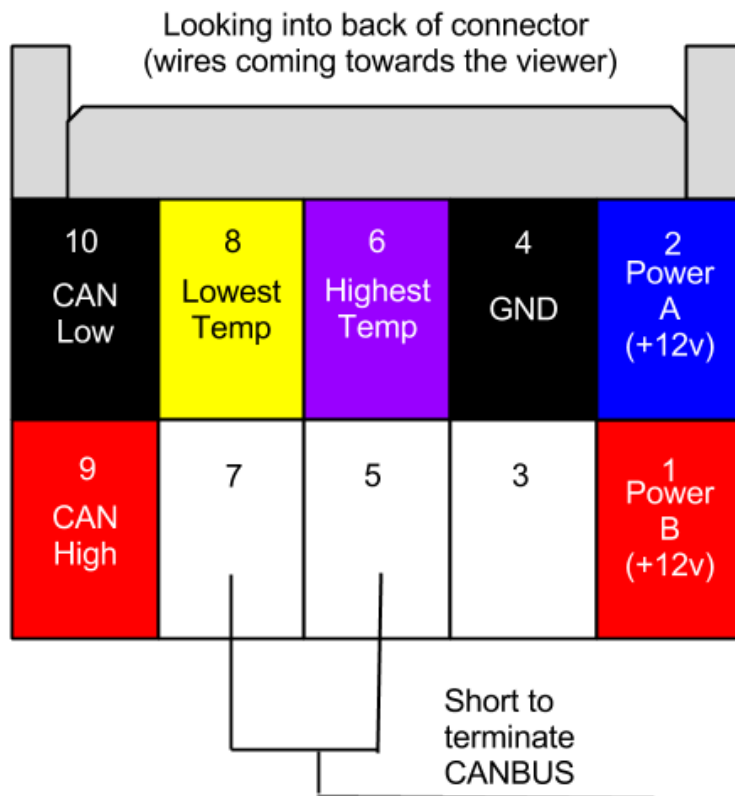

Revision B Power Connector (Plastic Enclosure)

Signal Name	Description
Power A (+12v)	<p>This is the primary +12v power source for the expansion module. The module will respond and act the same regardless of whether the power A or B signal is used to power it. A common configuration might be to use the Power A signal to power the module during normal operation and Power B signal to power it while charging. Another common configuration would be to power both A and B signals for redundancy.</p>
Power B (+12v)	<p>This is a secondary +12v power source for the expansion module. The module will respond and act the same regardless of whether the power A or B signal is used to power it. A common configuration might be to use the Power A signal to power the module during normal operation and Power B signal to power it while charging. Another common configuration would be to power both A and B signals for redundancy.</p>
Ground (NEG)	<p>This is the power ground for the board. It should be connected to ground.</p>
CAN-H	<p>This is the CANBUS high wire used to communicate with the Orion BMS. This should be shielded and twisted together with CAN-L.</p> <p>The CANBUS lines should be bridged with either the CAN1 or CAN2 interface on the Orion BMS.</p> <p>NOTE: There is NO internal termination resistor (120 Ohm) between CAN-H and CAN-L. It is the responsibility of the installer to verify that there are exactly two (2) termination resistors in the CANBUS network that the device is being installed in.</p>
CAN-L	<p>This is the CANBUS low wire used to communicate with the Orion BMS. This should be shielded and twisted together with CAN-H.</p> <p>The CANBUS lines should be bridged with either the CAN1 or CAN2 interface on the Orion BMS.</p> <p>NOTE: There is NO internal termination resistor (120 Ohm) between CAN-H and CAN-L. It is the responsibility of the installer to verify that there are exactly two (2) termination resistors in the CANBUS network that the device is being installed in.</p>

Highest Temperature	<p>This wire provides a voltage representation (0-3.3v depending on temperature) of the highest measured thermistor by the module.</p> <p>This can be directly connected to one of the 4 thermistor inputs on the main Orion BMS module if CANBUS communication is not possible (OPTIONAL, but not recommended).</p>
Lowest Temperature	<p>This wire provides a voltage representation (0-3.3v depending on temperature) of the lowest measured thermistor by the module.</p> <p>This can be directly connected to one of the 4 thermistor inputs on the main Orion BMS module if CANBUS communication is not possible (OPTIONAL, but not recommended).</p>

Software Configuration

There are two areas where the software (configuration) settings regarding the thermistor expansion module support can be adjusted. The first is the battery profile in the OrionBMS and the second is settings stored on the actual thermistor expansion module itself (CANBUS baud-rate, CANBUS ID, number of populated / loaded thermistors, etc).

Setting Up The OrionBMS Profile

The following instructions will enable the thermistor expansion module in the OrionBMS battery profile using the official OrionBMS utility (as shown below in screen shots). These steps assume that the user has already connected to the BMS and downloaded the most recent battery profile from the BMS (via the "Receive Current Profile From BMS").

Step 1: Under the "Addon Settings" tab in the "Battery Profile" section, enable the thermistor expansion module support, select which CAN ID the BMS should use to communicate with the expansion module and select how many modules are being connected.

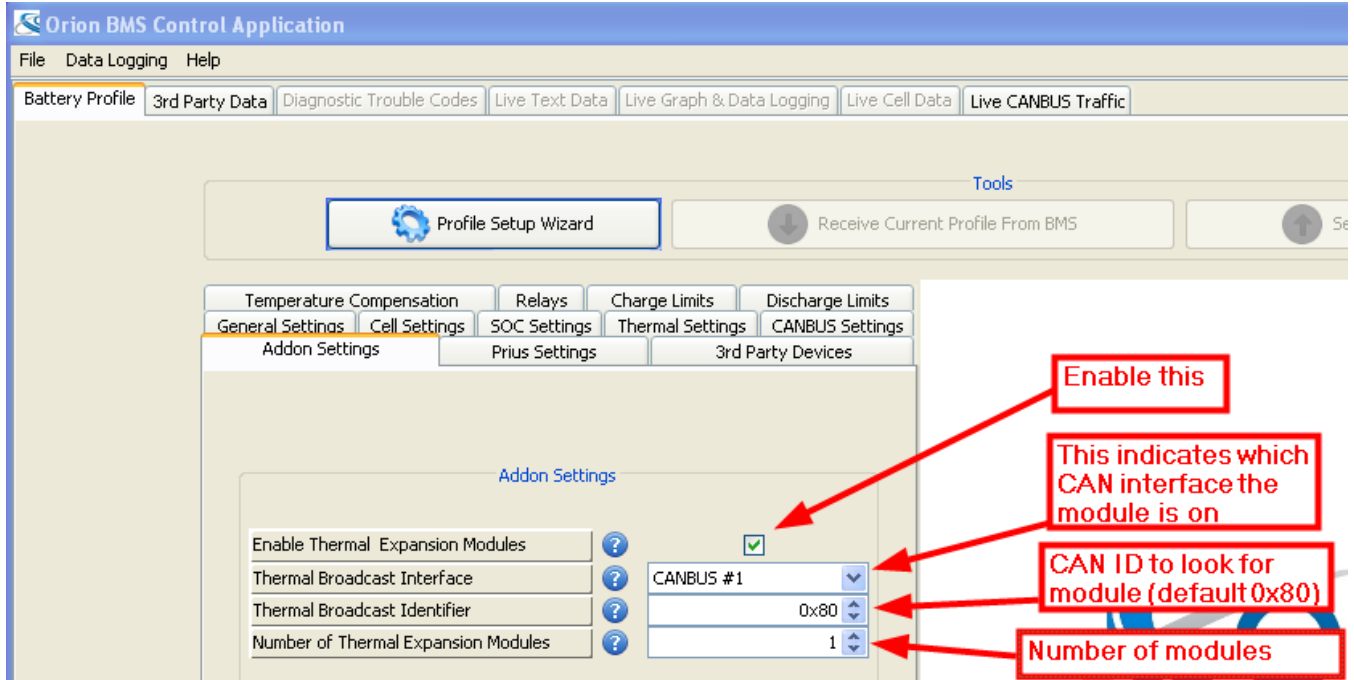

Step 2: Be sure to upload the new profile to the BMS using the "Send Profile Changes To BMS" button, otherwise the changes will not take effect.

Setting Up The Thermal Board Software

The following instructions assume that the user has installed the OrionBMS thermistor utility (available from <http://www.orionbms.com/support>).

Step 1: Connecting to the thermistor board is fairly straight forward. Make sure that a CANdapter (<http://www.candapter.com>) is connected to the computer and that the thermistor module is connected to the CANdapter via the CANBUS. Also make sure that the thermistor board is properly powered. If repeated attempts to connect to the thermistor board fail, please consult the troubleshooting section below.

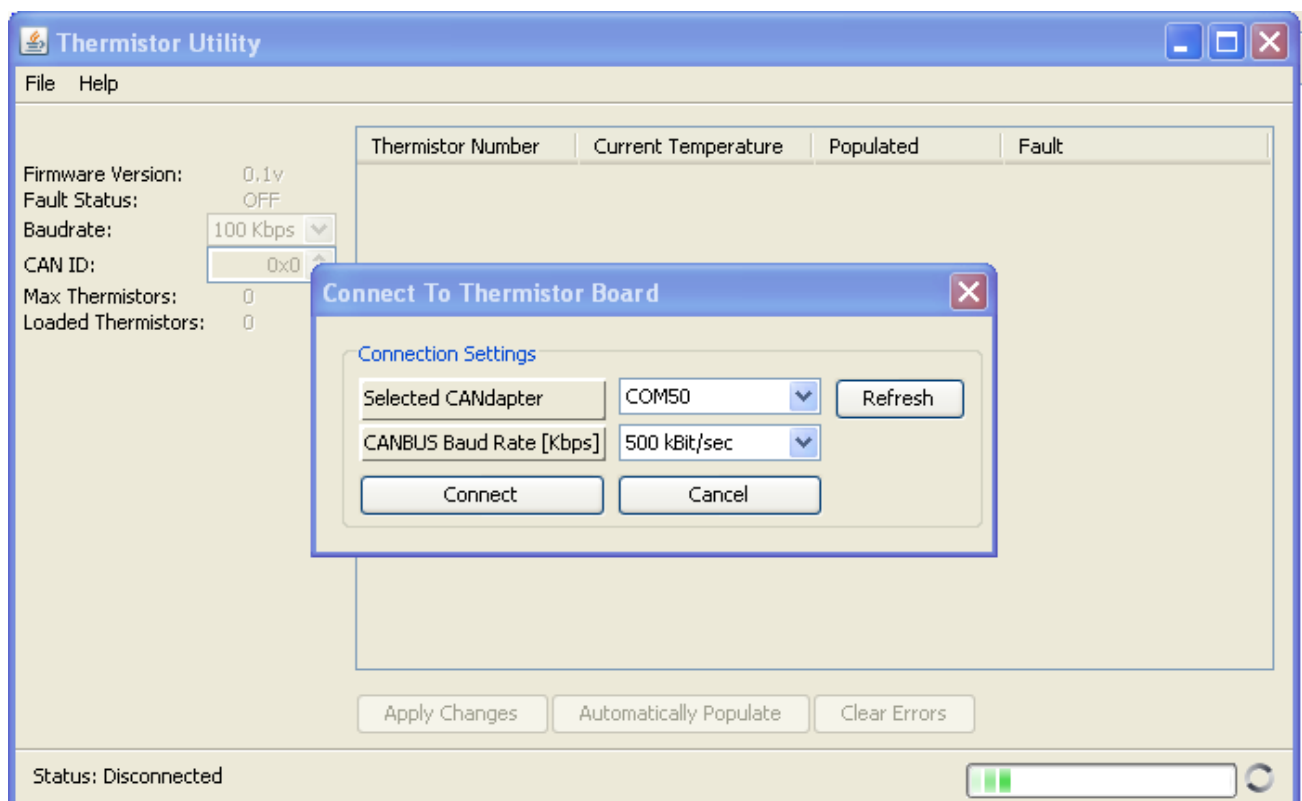
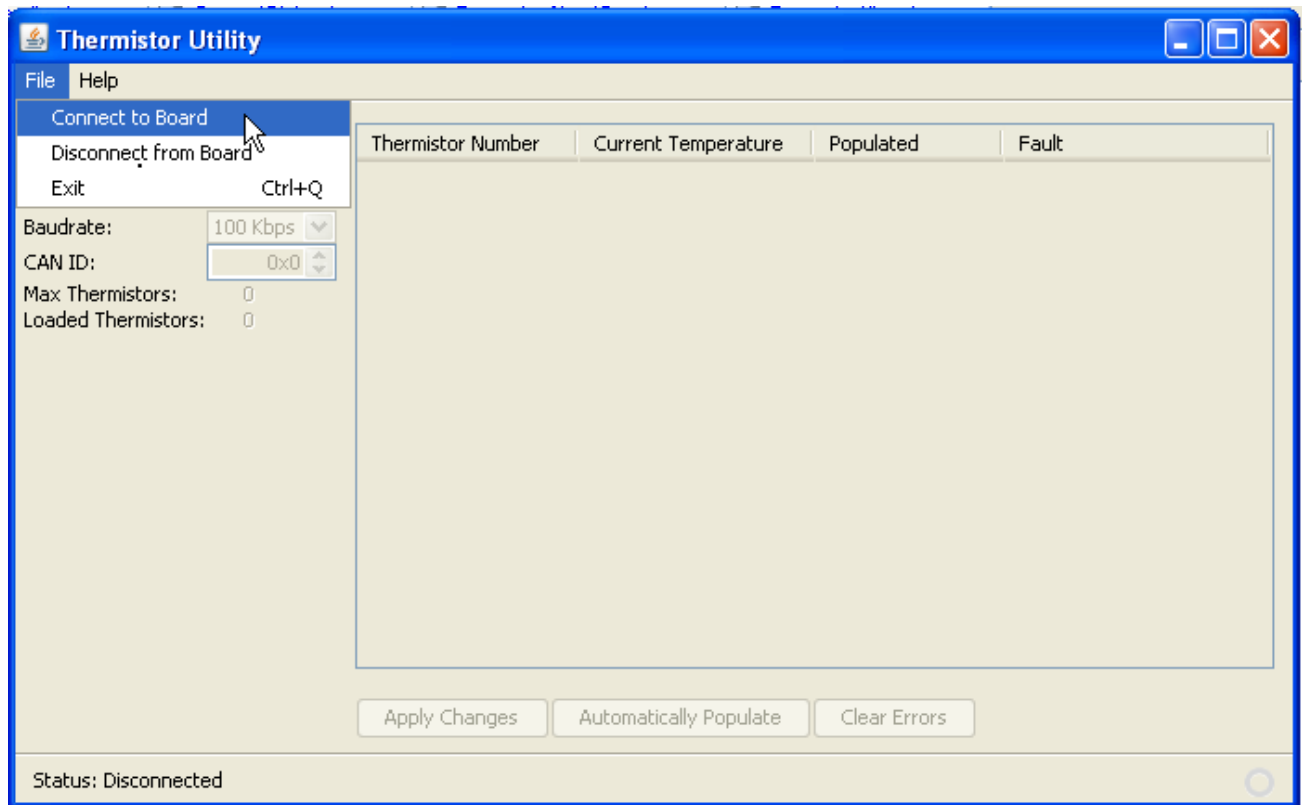

Step 2: Examine which thermistors are populated (loaded) and adjust these values accordingly. Any thermistors that are not loaded into the board connectors should be unchecked (unpopulated) to prevent an error code (fault code) from getting set.

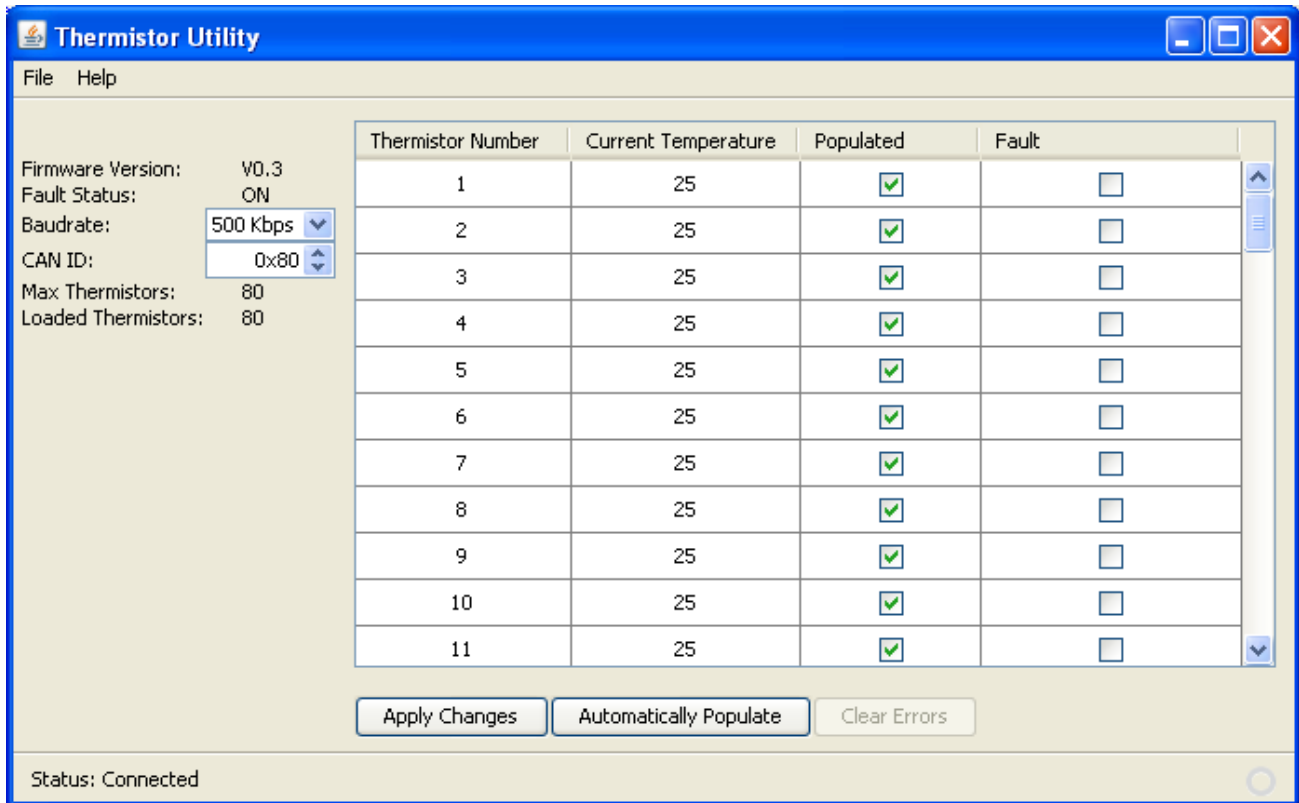

Step 3: Press the "Apply Changes" for any changes made to take effect.

Additional Thermistor Utility Features:

The thermistor utility allows the user to see all the measured thermistor values expressed in degrees Celsius (C). It also allows the user to see if any fault conditions are set (as noted by a checked box in the Fault column) on any given thermistors. The general "Fault Status" signal in the top left corner will turn "ON" if any thermistors are detected as faulty and will remain active until power to the board is lost (or the fault error codes are cleared using the "Clear Errors" button).

- The presence of any fault condition with any populated (loaded) thermistor measured by the board causes an error condition to be sent to the OrionBMS (if being used with the OrionBMS). The OrionBMS then sets a thermistor fault DTC (diagnostic trouble code) for the thermistor expansion module.
- Fault conditions with thermistors can be cleared using the "Clear Errors" button.
- The utility can automatically guess which thermistors are loaded if you push the "Automatically Populate" button. This cannot be trusted under all circumstances as it

- only is aware of thermistors that are connected and properly wired.
- Any changes made to the configuration (either by the drop down menus or the checkboxes) must be applied before they take effect (this is done by pushing the "Apply Changes" button).

Operation

During normal operation, the thermistor expansion board will constantly be monitoring each populated thermistor and reporting the highest and lowest observed temperatures to the Orion BMS via CANBUS (a secondary method is available using the analog outputs as well).

In the event of a thermistor fault (a thermistor is registering a temperature outside of the maximum temperature sensing range of -40 to +80C), the board will flag the offending thermistor as faulty, set the error flag and omit that thermistor from the calculated highest and lowest thermistor values.

Using the Thermistor Expansion Utility (not the main Orion BMS utility), thermistor faults can be read and cleared and real-time thermistor values can be read. This is helpful for diagnosing problems and determining temperature variance within a battery pack.

Troubleshooting

Problem Symptoms	Likely Cause & Solution
The Orion BMS sets a thermistor fault on this thermistor module.	<ul style="list-style-type: none"> • Verify that the thermistor expansion module is powered. • Verify that the CANBUS communication wires are connected properly (try connecting to the module using the Thermistor Expansion Utility). • Verify that the populated thermistor table is properly setup (ie: only thermistors that are loaded are enabled in the software, this can be accomplished through the Thermistor Expansion Utility). • Verify that the CANBUS baud-rate and broadcast identifier are correct both in the Orion BMS profile (through the main BMS utility) and in the thermistor expansion module settings (through the thermistor expansion utility).
I had an error condition with a thermistor but I fixed the problem and it is still reporting that there is a fault on that thermistor.	<ul style="list-style-type: none"> • The thermistor board will not clear fault conditions until either the power is cycled on the board (power reset) or the thermistor utility calls for faults to be cleared (via the "Clear Errors" button). This feature allows the thermistor board to ignore intermittently faulty thermistors entirely.

	<ul style="list-style-type: none"> • Either power cycle the board or clear the errors using the utility to solve this problem.
<p>The Thermistor Expansion Utility cannot establish connection to the thermistor expansion module.</p>	<ul style="list-style-type: none"> • Verify that the thermistor expansion module is powered (at least one of the redundant power supplies (power A or power B or both) is reading +12v). • Verify that the CANBUS wiring is correct (CAN-H and CAN-L must be correct). • Verify that there is the proper number of termination resistors on the CANBUS (there must be exactly 2 termination resistors [120 Ohm each]). This can be verified by checking the resistance between CAN-H and CAN-L. It should read approximately 60 Ohm. <u>There is NO internal termination resistor inside the thermistor module.</u>

Electrical & Product Specifications

Thermistor Electrical Specifications:

10K NTC Thermistors with a B25/50 value of 3380K

Expansion Module Dimensions:

14.3 cm (W) x 9.3 cm (L) x 4.4 cm (H)

Item	Min	Typ	Max	Units
Supply Voltage	9		16	Vdc
Operating Temperature Range	-40		80	C
Temperature Sensing Range	-40		80	C
Module Weight		11		oz



An Ewert Energy Systems, Inc Product

The Orion BMS and this expansion module are designed and manufactured by Ewert Energy Systems, Inc which is a research & development company focusing on developing solutions for plug-in hybrid and electric vehicles. Ewert Energy provides custom solutions as well as off the shelf components.