

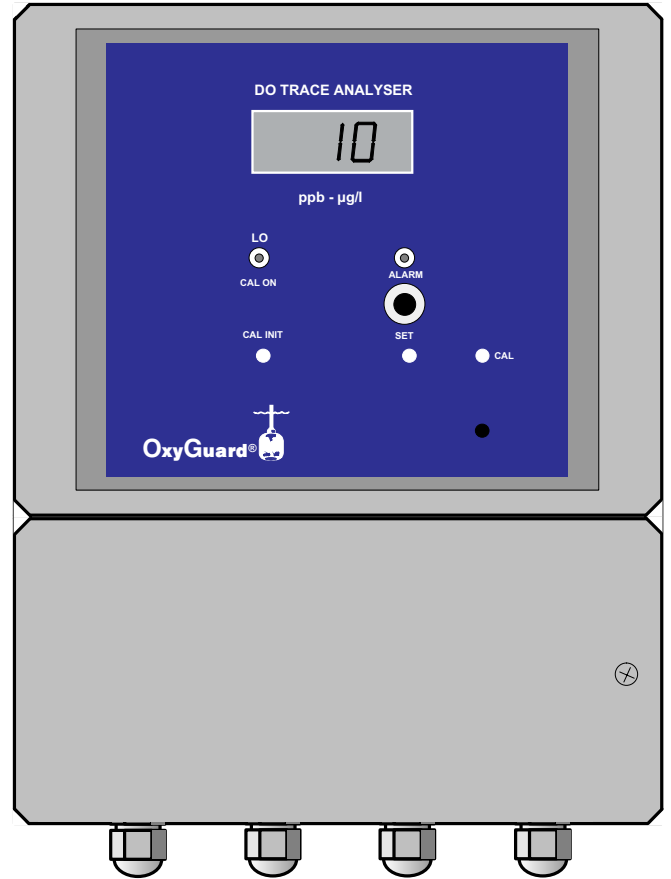

# Oxyguard PPB

for the measurement of Dissolved Oxygen at ppb levels (microgram per liter)

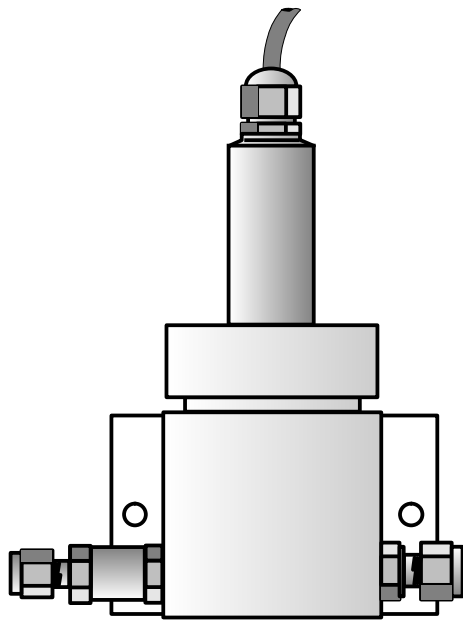

## Information

The OxyGuard PPB is specially designed for the measurement of dissolved oxygen in boiler feed water, condensate, district heating water and other types of water with low dissolved oxygen content.

The analyzer consists of a probe mounted in a measurement chamber, and a transmitter unit with alarm and analogue output signals. The unit is mains powered.

The instrument is extremely easy to use and maintain - no special training being needed. The probe, a galvanic cell that generates a voltage in the presence of oxygen, never needs replacing, and is insensitive to wide changes in sample flow and temperature. The system exhibits excellent accuracy, long-term stability and response time.

## **Probe**

This is manufactured almost entirely in stainless steel to give the greatest possible mechanical stability and maximum protection from electrical interference. The sensor itself uses new technology. The result is a probe with short response time and excellent calibration stability. The very robust membrane can, if necessary, be changed in a few minutes.

## **Measurement Chamber**

This is manufactured from clear acrylic plastic with stainless steel fittings. The clear plastic permits observation of the probe, an advantage when removing air bubbles after calibration. All the probe and measurement chamber materials can withstand high radiation levels, and can be used in nuclear power stations.

## **Transmitter**

This consists of a high-quality industrial type instrument amplifier in an IP65 cabinet, with digital display, 0-20 or 4-20 mA analogue output that is galvanically isolated from the input, and a high level alarm with potential-free change-over contacts. A special circuit disables the alarm during calibration. This is controlled by a timer, but can be reset manually.

## **Commissioning and Use**

Procedures for the connection and use of the instrument are straightforward, as verified by an independent testing institute (KEMA, Holland). Calibration is performed in air and usually takes about 1 minute. This short time ensures negligible contamination of the probe by atmospheric air, resulting in a return to accurate measurement in low (ppb) oxygen concentrations in the course of a few minutes!

## **Service and Maintenance**

The probe is constructed to operate for many years without needing maintenance. The choice of anode, cathode and electrolyte is such that only the anode is consumed, and this has a nearly infinite calculated lifetime at 10 ppb! The electrolyte remains unaltered, and does not need changing as in conventional systems. Practical tests indicate that the probe, used at 10 ppb, will only need service if the membrane should be damaged, and this is very seldom since the membrane is very robust - it is 0.05 mm thick. If membrane replacement should be necessary the procedure is easy and can be performed by anyone, without prior training.

## Transmitter Unit

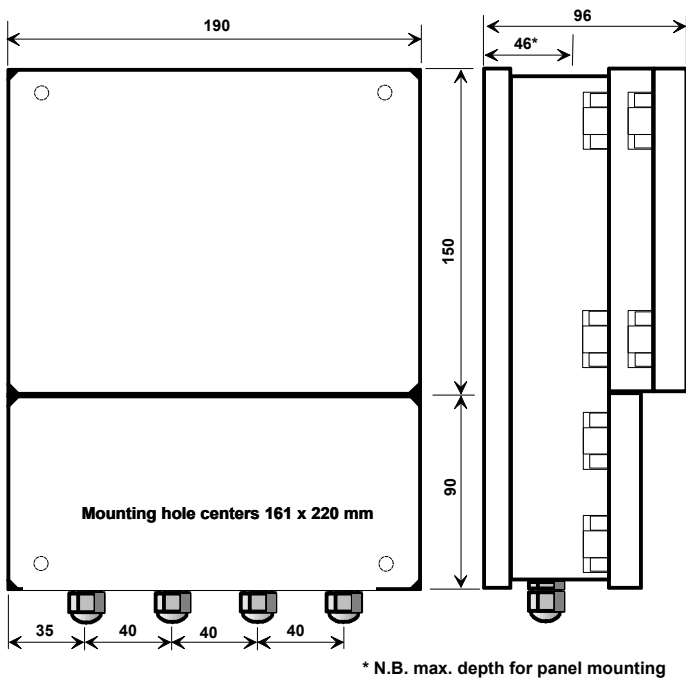

## Measurement Chamber with Probe

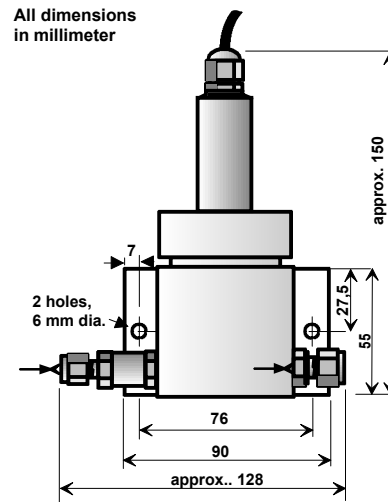

## Installation Example with Sample Cooler

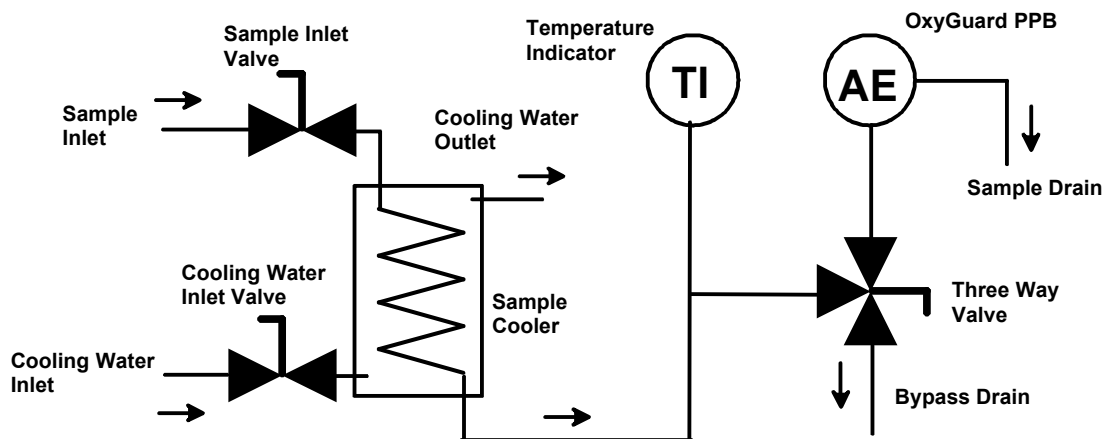

# Teknisk specifikation

## Probe

Type:	Self polarizing (galvanic) membrane covered amperometric cell
Sample temperature:	5°C to 50°C
Sample flow:	Depends on oxygen content and temperature - min. 50 ml/min, max 2000 ml/min.
Sample pressure:	Atmospheric
Connections:	6 mm compression ring fittings
Response Time:	20 sec for 0-5 and 0-80 ppb up-scale and down-scale. From 1 minute in air (calibration) to 100 ppb in approximately 40 sec, and to 10 ppb in less than 3 minutes.

## Transmitter

Measuring range:	0-100 ppb (or on request) (2-range version available)
Output:	0/4-20 mA, isolated from input
Indicator:	LCD display, digit height 12 mm
Alarm:	1 high alarm. Potential free change over switch, max. 200 VA
Encapsulation:	IP 65
Operating temperature:	-5°C to 60°C

## Practical System Performance

Accuracy:	Error max. 0.5 ppb (or 3%).
Repeatability:	Better than 0.5 ppb (or 2%).
Conformity:	Linear.
Limit of Detection:	0.8 ppb.
Long term stability:	0,5 ppb (1 month).
Commissioning:	Straightforward.
Probe renovation:	Easy. (N.B. only necessary if the membrane is damaged).

**N.B. The system has EMC (CE) approval**

## Standard Accessories

2 m flexible sample tubing	Membranes	User Manual
O-rings	Electrolyte	

## Ordering Information

L01S1: Stationary PPB oxygen meter.  
L01S2: Stationary 2-range PPB oxygen meter.

## Spares:

L01XPB:	PPB Probe
L01EL50:	50 ml PPB electrolyte.
L01XMEM:	Set of membranes and O-rings