

INDEX

CHAPTER 1- SUMMARY OF USER'S COMMANDS.....	3
CHAPTER 2 – ABOUT THE KEYPAD	4
DSM-205KP (LED KEYPAD)	4
LED INDICATION AND KEYS.....	5
FUNCTION AND OPERATION.....	6
1. Setting/Changing and Deleting User's Code	7
2. Setting Date and Time	8
3. Setting Follow-me Number	9
4. Quick Arming	9
5. Code Arming.....	10
6. Bell Squawk on Arming.....	10
7. Disarming.....	10
8. On/Off Audible kiss-off	10
9. Duress Disarming	10
10. Cutting off Sounder and Stop Auto-dialing	11
11. Bypassing/ Un-bypassing a Zone.....	11
12. Escape Key [ESC]	12
13. Emergency Keys.....	12
14. Entry and Exit Delays	12
15. 24-Hour Zone.....	12
16. Trouble Display	13
17. Zone Features	13
18. On/Off Door Chime	14
CHAPTER 3 - INSTALLATION.....	15
BEFORE INSTALLATION	15
FAQ. OF INSTALLATION AND SOLUTION	15
THE MAIN BOARD	16
INSTALL CONTROL PANEL AND KEYPAD.....	20
CONNECT THE TELEPHONE LINE.....	20
CONNECT THE STANDBY BATTERY	20
CONNECT TRANSFORMER.....	20

CONNECT SIREN.....	20
CONNECT DETECTOR(S).....	21
CONNECT VOICE MODULE	21
CONNECT WIRELESS RECEIVER	22
CHAPTER 4 - FUNCTION AND TECHNICAL DATA.....	25
MAIN FEATURES OF DSM-205KP	25
MAIN FEATURES OF DSM-205MB	25
RESTORING FACTORY DEFAULTS	29
PROGRAM EXPLAIN.....	29
CHECK LOCATION DATA.....	29
CHECK LOCATIONS OCCUPY MORE THAN ONE DIGIT WITH LED KEYPAD.....	30
ENTRY/EXIT PROGRAM	31
A PROGRAMMING TUTORIAL.....	31
General System Parameters: Locations 00-07	32
Installer Code : Location 08-10	33
SYSTEM TIME : LOCATIONS 11-13	33
INTRUSION ZONE TYPES AND ZONE SOUNDS : LOCATIONS 14-18.....	34
UTILITY OUTPUTS- EVENT AND RESULT : LOCATIONS22, DEFAULT 00.....	36
COMMUNICATION PARAMETERS : LOCATIONS26-29	38
CENTRAL STATION PROTOCOLS : LOCATION 27, DEFAULT: 00.....	39
CS PROTOCOLS: LOCATION 28, DEFAULT: 03.....	41
PERIODIC TEST TIME : LOCATION 31	43
COMMUNICATOR REPORTING CODES : LOCATIONS 32-94	43
REPORTING CODES FOR ALARM EVENTS:	43
DSM-205 CONTROL PANEL CONTACT ID REPORTING CODES.....	46
ROISCOK'S WARRANT.....	错误！未定义书签。

CHAPTER 1- SUMMARY of USER'S COMMANDS

The Summary of User's Commands offers installers and users a quick and convenient way to operate control panel. All can be done under the state of disarm and so it doesn't need to enter programming statue. For detailed information, please go chapter 2.

Function	Procedure
Quick arm	[ARM]
Arm by code	[ARM]+[master code]
Quick Stay Home Arm	[STAY]
Arm within zones by code	[STAY]+[master code]
Silencing an Alarm	[user code]
Duress disarm	[duress code]
System Disarm	[user code]
Bypass/unbypass a zone	[*]+[1]+[user code]+[zone number]
Bypass/unbypass a zone	[zone No.]at least 2 seconds
Set/change the master code	[*]+[5]+[master code]+[0]+[new code]
Set/change a user code	[*]+[5]+master code+[1-9]+[new code]
Set date	[*]+[6]+[1]+[master code]+[MM][DD][YY]
Set time	[*]+[6]+[2]+[master code]+[H][H][M][M]
Daily Auto arm	[*]+[6]+[3]+[master code]+[H][H][M][M]
Set follow-me phone no. 1	[*]+[7]+[1]+[master code]+[phone No. 1]+[#]
Set follow-me phone no. 2	[*]+[7]+[2]+[master code]+[phone No. 2]+[#]
Set follow-me phone no. 3	[*]+[7]+[3]+[master code]+[phone No. 3]+[#]
Set follow-me phone no. 4	[*]+[7]+[4]+[master code]+[phone No. 4]+[#]
On/off buzzer	[*]+[8]+[master code]+[1]
On/off door chime	[*]+[8]+[master code]+[2]
Audible kiss-off	[*]+[8]+[master code]+[3]
Test system	[*]+[0]+[master code]
keypad panic alarm	[1]+[2] at least 2 seconds
keypad fire alarm	[4]+[5] at least 2 seconds
keypad special emergency	[7]+[8] at least 2 seconds
Escape	[ESC]

Trouble Table	LED	Trouble
	Zone 1	The Backup Battery Power is low.
	Zone 2	AC Power is lost.
	Zone 3	Clock have not been set
	No Siren	The Siren connection is in trouble.

CHAPTER 2 – ABOUT THE KEYPAD

DSM-205KP (LED Keypad)

The DSM-205 support LED Keypad.

The keypad in your system reports its status by its LED (lighted) indicators. Through its keys, you can enter commands to Arm and Disarm the system, bypass intrusion zones, report emergencies, stop the siren, checking the trouble, programming the system and other handling.

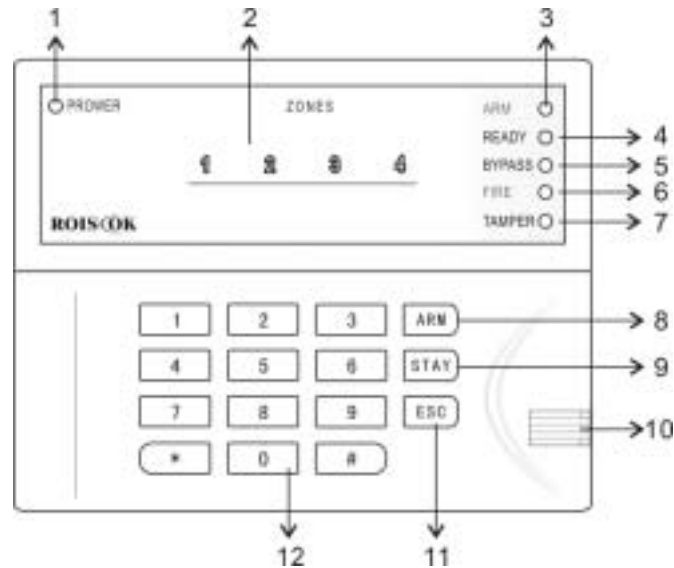

Fig.1 Layout of the DSM-205KP

Keypad Instruction

- | | |
|------------|-----------------------------------|
| 1 - Power | 7- Tamper |
| 2 - Zones | 8 - Arm key-press |
| 3 - Arm | 9 - Stay key-press |
| 4 - Disarm | 10 - Buzzer |
| 5 - Bypass | 11 - Exit/Delete key-press |
| 6 - Fire | 12 - Digit and Function key-press |
-

LED Indication and Keys

1. Power LED

- On--The system is operating properly from commercial (AC) power; its backup battery is in good condition.
- Off--The system is inoperative due to the lack of power (from both commercial AC and backup battery).
- Flash-- Indicates a trouble condition.

2. Zone LEDs

The **LED(s)** indicate the status of each of the system, including zones Triggered, Armed/Disarmed system, Trouble, Time and other programming information.

3. ARM LED

The **ARM LED** indicates whether or not the system is armed. In armed condition, the ARM LED is on, in case of any violations, there will be an alarm. The ARM LED is flashing, which means burglar, fire or emergency alarm once has/have occurred in the corresponding zone(s). The ARM LED is off when the system is disarmed.

Statue	EXPLANATION
On	When the system is armed, in case of any emergency, an alarm will occur. The Siren will sound, and system will also dial the follow-me numbers and send alarm report to alarm center.
Off	The system is disarmed.
Flashing	Burglar, fire and/or has/have once occurred.

4. READY LED

The Ready LED indicates whether the system is working normally or not, and also indicates whether system can be armed or not. When disarm, the LED will be on; when arm, the LED will be off.

STATUS	EXPLANATION
On	All the zones are working normally, and then the system can be armed now.
Off	1. Someone is moving in the zone. 2. The system is armed.
Flashing	The system is under the programming status

5. BYPASS LED

The **BYPASS LED** Indicate that one or more of the system's intrusion zones have been bypassed; for more information on bypassing.

6. FIRE LED

When fired the LED flashing rapidly.

7. TAMPER LED

When the detector(s) or the keypad is /are tampered or destroyed, a Tamper Code report will be sent and the LED will be flashing.

8. System Arming [ARM]

When [ARM] key depress, all the zones are all armed.

9. Stay Home Arming [STAY]

Home Arming (or Stay Arming) allows individuals to remain inside and move about the premises even after the system is armed. Home Arming arms the perimeter detectors (e.g. door and windows), while leaving interior detectors (e.g. motion detectors) disarmed (bypassed). When [STAY] key is depressed, the interior zones will not be armed.

10. Exit/Delete [ESC]

Key [ESC] is suitable for correction system operation

11. Digit Keys

When programming, key in 0-9 digits.

12. Function Key [*] [#]

When programming, key [*] to enter function mode; and [#] for confirmation.

Function and Operation

Keys and Functions

The Keys can support the following functions:

1. Enter digit(s) for Arming, Disarming, Panic Alarm, Programming etc.
 2. Enter user's function mode.
 3. Key [ARM] is for Quick Arming and Code Arming. By pressing it, the system will be fully armed.
 4. Key [STAY] is for Quick Stay Arming and Code Stay Arming. By pressing it to arm, only part of the zone is armed. Each zone can be set as interior zone or external zone. When use [STAY] for arming, the external zone is armed while leaves the interior zone disarmed.
 5. Under the disarmed status, press [*] to enter user's function mode.
- Reference to **CHAPTER 1- SUMMARY of USER'S COMMANDS**

1. Setting/Changing and Deleting User's Code

The default Master Code of DSM-205 is 1-2-3-4. Unless your alarm company has already changed it to suit your preference, it's best to modify this code to one which is unique and personalized. DSM-205 can set 10 of Codes, one is Master Code and another 9 are User's Codes. To change the Master Code, and /or to set up User Coeds, follow the steps. Make sure the system is disarmed when setting the code. The User's Codes are only for Arming and Disarming the system

Functions of the Master Code:

- Adding, changing and deleting User's Code
- Setting Time Clock
- Operating and testing
- Setting the follow-me numbers

Setting / Changing the master Codes

Step	Operation
1	The system must be disarmed (the ARMED LED will be OFF). Enter the User Functions Mode [*][5]
2	Enter the current 4-digit Master Code: For example, Press [1][2][3][4]
3	Press [0]
4	Enter the new 4-digit code selected will emit a one-second confirming tone. The selected User Code is now in effect. For example, press[5][6][7][8]
5	If successful, the keypad will emit a confirming tone "Beep - ". The selected User Code is now in effect.

Setting/Changing 1-9 User Codes

At times, it may be desirable to completely delete a User Code. Note that it is impossible to delete the Master Code (although it can be changed).

Step	Operation
1	The system must be disarmed. Enter the User Functions Mode [*] and choose Codes [5] Press [*][5]
2	Enter the current 4-digit Master Code: For example, [5][6][7][8]
3	To set/delete the User Code 1, press [1] To set/delete the User Code 2, press [2] To set/delete the User Code 3, press [3] ... The other Codes can be set/deleted in the same way.
4	Enter the new User Code: For example, [3][3][5][5]
5	If successful, the keypad will emit a confirming tone "Beep - ". The selected User Code is now in effect.

Deleting User's Codes

At times, it may be desirable to completely delete a User Code. Note that it is impossible to delete the Master Code (although it can be changed).

Step	Operation
1	The system must be disarmed. Enter the User Functions Mode [*] and choose Codes [5], Press [*][5]
2	Enter the current 4-digit Master Code: [5][6][7][8]
3	To delete the User Code1, press [1] To delete the User Code1, press [2] To delete the User Code1, press [3] ... The other Codes can be deleted in the same way.
4	Enter the [#]
5	If successful, the keypad will emit a one-second confirming tone. The selected User Code is now deleted.

2. Setting Date and Time

Set date: [*][6][1][MASTER CODE][MM][DD][YY]

Month, Date and Year should all be two digits.

Set time: [*]+[6]+[2]+[MASTER CODE]+[HH][MM]

Use a 24-Hour format. Hour and Minute should be two digits.

For example, if you want to enter 16:28, August 18, 2006, operate as :

[*]+[6]+[1]+[MASTER CODE]+[08][18][06]

[*]+[6]+[2]+[MASTER CODE]+[16] [28]

3. Setting Follow-me Number

In case of an alarm event, a phone call can be made to one or more predefined phone number. There are three different tone types that represent burglary, fire and special emergency alarms.

The Follow-Me function can support four phone numbers for each system.

Make sure the numbers are all correct; then enter [#]. Operate as:

Set Follow-Me Phone NO.1: [*]+[7]+[1]+[MASTER CODE]+Phone NO.1+[#]

Set Follow-Me Phone NO.2: [*]+[7]+[2]+[MASTER CODE]+Phone NO.2+[#]

Set Follow-Me Phone NO.3: [*]+[7]+[2]+[MASTER CODE]+Phone NO.3+[#]

Set Follow-Me Phone NO.4: [*]+[7]+[2]+[MASTER CODE]+Phone NO.4+[#]

4. Quick Arming

DSM-205 can be divided as interior zone and external zone by programming.

Zone 7 and Zone 8 are defaulted as interior zone.

Press [ARM], and all the zones will be armed.

Press [STAY], then external zone will all be armed while leaves the interior zones disarmed.

Step	Operation
1	Before you arm your system, all of its zones must either be secured or bypassed .The keypad's READY LED, if lit, indicates that all zones are secured.
2	Quick Arming and Code Arming: <ul style="list-style-type: none">● Quick Armed : Armed the system just by press [ARM].● Quick Stay Armed : Stay Armed just press [STAY].
3	Three short Beep from the keypad when there are some errors in entering. Then re-operate it.
4	When arming the system, there will be one confirmation sound, which means the exit delay begin now. Then leave here before the exit delay time is over to avoid false alarm. The exit delay

	time is defaulted as 30 seconds.
--	----------------------------------

5. Code Arming

Your DSM-205 offers two methods of arming, Quick Arming and Code Arming. It's defaulted as quick arm. If the user requires code arm, it should be set when programming in advance.

When DSM-205 is set as code arm, it can not support [ARM] and [STAY] for quick arming. And it should be operated as: [ARM] + [Master Code], or [STAY] + [Master Code] to arm or stay arm.

6. Bell Squawk on Arming

If selected, Bell Squawk on Arming will produce a brief confirmation "chirp" from the system's external sounder(s) once the system is armed and the Exit Delay expires. To cancel it, refers to Location 30 in Chapter 5.

7. Disarming

DSM-205 can set 10 Codes (4 digits), one Master Code and 9 User Codes. In arming status, simply enter any code of the 10 codes to disarm.

Step	Operation
1	When enter the arming zone, the keypad will "beep" one time, which means the system is in entry delay status. The entry delay time is defaulted as 30 seconds.
2	<p>Disarming an armed system</p> <p>Before the Entry Delay expires, enter the four digits of your User Code. Or it will alarm.</p> <p>NOTE: If you make a mistake when entering your User Code, the keypad will produce three short beeps and the LCD keypad will display error. If so, press ECS and re-enter the above sequence correctly.</p>

8. On/Off Audible kiss-off

When disarm the keypad will send out a long Beep at the end of the Delay time. Press [*]+[8]+[User's Code]+[3] to on/off the buzzer.

9. Duress Disarming

If you are ever coerced to disarm your system, you can comply with the

intruder's wishes while sending a silent, duress alarm, to the Central Station. To do so, you must use a special Duress Code.

Which when used, will disarm the system in the regular manner, while simultaneously transmitting a silent alarm to the central station. All 10 codes (including one Master Code and 9 User Codes) can activate the Duress disarming by adding 1 to The last digit of your user codes. The Duress Code and the User code share the first 3 digits. Example:

User code =1-2-3-4; duress code is 1-2-3-5

User code =5-6-7-8; duress code is 5-6-7-9

User code= 7-8-9-0; duress code is 7-8-9-1

Note: Under no circumstances must the Duress Code be used haphazardly or without reason. Central Stations, along with Police Departments, treat Duress Codes very seriously and take immediate action.

10. Cutting off Sounder and Stop Auto-dialing

If outside premises, open an entry door; the keypad(s) will beep indicating that the Entry Delay period has begun. The entry delay is defaulted as 30 seconds.

Silencing an alarm in progress

Observe the keypad. If any of the following conditions is evident, an alarm has occurred and enter the master or user's code to silencing an armed system:

- The ARM LED is flashing
- Zone(s) LED will turn on

Disarming an armed system

Before the Entry expires, enter the four digits of your User Code.

NOTE: If you make a mistake when entering your User Code, the keypad will produce three short beeps and the LCD keypad will display error. If so, press ECS and re-enter the Code.

11. Bypassing/ Un-bypassing a Zone

When an intrusion zone is bypassed, the zone will not be armed when arming.

When disarming, all the bypassed zones will be automatically un-bypassed.

There are two methods of Bypassing:

Quick Bypassing: It's defaulted that all the zones of DSM-205 can be set as Quick Bypass. Bypass a zone, simply press the corresponding key for or above 2 seconds. For example, to bypass Zone 3, press digit 3 for 2 seconds. Use the same way to un-bypass the bypassed zone.

Code Bypassing: If DSM-205 was programmed as code bypassing, then press: [*]+[1]+[Disarming Code]+[Zone No] to bypass the zone. Use the same way to un-bypass the zone.

12. Escape Key [ESC]

Keypad [ESC] is suitable for correction system operation.

13. Emergency Keys

The keypad (DSM-205KP) provides three emergency keys, which can be pushed at anytime, and the police, fire department, or medical assistance is required. Emergency Alarm is defaulted as silence alarm.

- Press 1 and 2 simultaneously, and for at least two seconds, will activate a Panic Alarm.
- Press 4 and 5 simultaneously, and for at least two seconds, will activate a Fire Alarm.
- Press 7 and 8 simultaneously, and for at least two seconds, will activate a Medical Emergency.

14. Entry and Exit Delays

Your security system must incorporate in and from the premises without causing inadvertent alarms. A delay period was chosen during your system's installation to provide suitable time to allow for your entry and exit. Entry/Exit Delays can be set by programming, and it's defaulted as 30 seconds. To change the delay time, refer to location 11-13 of Chapter 5.

15. 24-Hour Zone

DSM-205 support several kinds of zones. All other forms of protection, including fire and 24-hour panic alarms (i.e. police, fire, and medical) are always ready to report alarms and do not need to be armed.

16. Trouble Display

When the keypad sends out three short beep regularly, indicating that the system exists some troubles. When get rid of the troubles, the system will restore to normal status and stop beeping. Troubles include Battery Low, AC power, No Clock, No Communication, No Siren etc. Press [*]+[3] to search on the Zone's LED. The troubles displayed as follow:

Trouble Table	LED	Trouble
	Zone 1	The Backup Battery Power is low.
	Zone 2	AC Power is lost.
	Zone 3	Clock have not been set
	TAMPER	The Siren connection is in trouble.

17. Zone Features

DSM-205 has 5 programmable zones. Each zone can be programmed as Entry/Exit Delay Zone, Instant (Intrusion) Zone, Panic Zone, Fire Zone, Tamper Zone, Remote Zone etc.

Entry/Exit Delay Zone: A delay period was chosen during your system's installation to provide suitable time to allow for your entry and exit. Exit Delay is the max time from pressing the ARM key to exit the zone; Entry Delay is the max time from entering the zone to DISARM. If the time exceeds the max time and the detector is triggered again, then the system will alarm at once.

Instant Intrusion Zone: When it is triggered, the system will alarm instantly.

Panic Zone: Used for panic button, which is 24-Hours Zone

Fire Zone: Used for smoke detector and gas detector, which is 24-Hours Zone

Tamper Zone: Used for connecting with the tamper connector of detector, which is 24-Hours Zone

Remote Zone: Used for connecting with remote receiver, which is 24-Hours Zone

For user's convenience, all DSM-205 zones have been defaulted as following:

Zone 1: Entry/Exit Delay Zone;

Zone 2: Instant (Intrusion) Zone;

Zone 3: Panic Zone;

Zone 4: Tamper Zone;

Zone 5: Fire Zone;

18. On/Off Door Chime

Assigned to an opening which, when violated during the disarmed, will cause the system's keypad(s) to beep once during an alarm, the external sounding device will annunciate continuously, without interruption. When alarm occurs during armed system only the external sounder will be activated. Enter [*]+[8]+[Master Code]+[2] to turn on/ off the door chime.

CHAPTER 3 - INSTALLATION

The Series of Control Panel Which is Designed and Produced by ROISCOK Integrate Perfect Function and Advanced Technology. ROISCOK's Control Panels Use the Separated Control Keypads and Has Strong Ability to Prevent Destroy. All Zones Are Programmable, Have Built-in Digital Communicator, Flexible Connecting to Alarm Centre, Compatible to All Popular Communication Format, Attached Duress Code, Consecutive Output. With Easier Programming and More Elegant Shape, Everywhere Shows the Products' Luxury.

The **DSM-205** are intended to address the needs of many homes, offices, and small businesses. Its operation is designed around microprocessor and EEPROM (Electrically Erasable Programmable Read-Only Memory) technology, which stores, without the need for a source of power, the system's operating program and its programmable parameters.

System programming can be performed through keypad.

Before Installation

You shall read the all the subjects in manual deeply before installation to avoid unnecessary damage to the products.

Please use the tool correctly, you should install the system first, then power the systems.

Please make sure the systems are not powered when you handle the connection. Otherwise this can make the system self-protection, the components burning or other problems!

The 2.2kΩ resistors which dispensed with the systems should connect with the nearest location of the detector (Fig.3).

FAQ. of Installation and Solution

The DSM-205 has self-protection system and self-check function. The Keypad will make a sound to prompt the user to check up and Correction when systems are installed or set in error.

1. Please check if the tamper button on the back of the keypad installed in the correct and under working conditions when keypad emit the continuous "beep-" after system installation is complete and be powered.
2. Please review the chapter 2 No.16 Trouble Display, when keypad notified a rhythmic "beep, beep, beep". In that case may including the following situation: battery power shortages, AC power off, no set clock (time and date), the phone lines for communications or the line for alarm has a fault.
3. Keypad will emit three sound "beep, beep, beep" when input the wrong operation.
4. Please check whether the connect between the port "ALARM" on the detector and control panel is connected firm and connected the 2.2k ohm resistor correctly when the Siren alarmed under armed state.
5. Please check whether the cover of detectors is installed correctly , the tamper switch of detector is ready, The connect between the port "TAMPER" on detector and control panel is connected firm and connected the 2.2k ohm resistor correctly when the Siren alarmed under disarmed state.

The Main Board

As Figure 2, the function as following:

- 1 - The port "LINE" for telephone line input
 - 2 - The port "PHONE" for telephone set
 - 3 - Dialing LED Indicator
 - 4 - The connector for the voice module
 - 5—Eligible label and production serial number
 - 6 - The jumper "DEFAULT" for restore factory defaults
 - 7 - The CPU and type and version number
 - 8 - "AUX" safety for assistant power, 0.5A
 - 9— "BELL" safety for siren power, 1A
 - 10 - "BAT" safety for standby power, 2A
 - 11/12 - "AC" input to the main board (AC16.5V)
 - 13 - Connect to the ground
 - 14 - "BAT-" the cathode of the standby power
 - 15 - "BAT+" the anode of the standby power
-

- 16 - "AUX" connect to the anode of detector(s) "DC12V+"
 - 17 - "BELL+" connect to the anode of detector
 - 18 - "BELL-" connect to cathode of detector
 - 19 - "UO" Utility Outputs
 - 20 - "Z1" the port for zone 1, defaults as Entry/Exit Delay Zone. Connect to one port of "ALARM" on the detector.
 - 21/24 - "COM" the communal port
 - 22 - "Z2" for zone 2
 - 23 - "Z3" for zone 3
 - 25 - "Z4" the port for zone 4
 - 26 - "Z5" the port for zone 5
 - 27 - "GRN" the port should connect to the green line on the keypad.
 - 28 - "YRL" the port should connect to the yellow line on the keypad.
 - 29 - "BLK" the port should connect to the black line on the keypad.
 - 30 - "RED" the port should connect to the red line on the keypad.
-

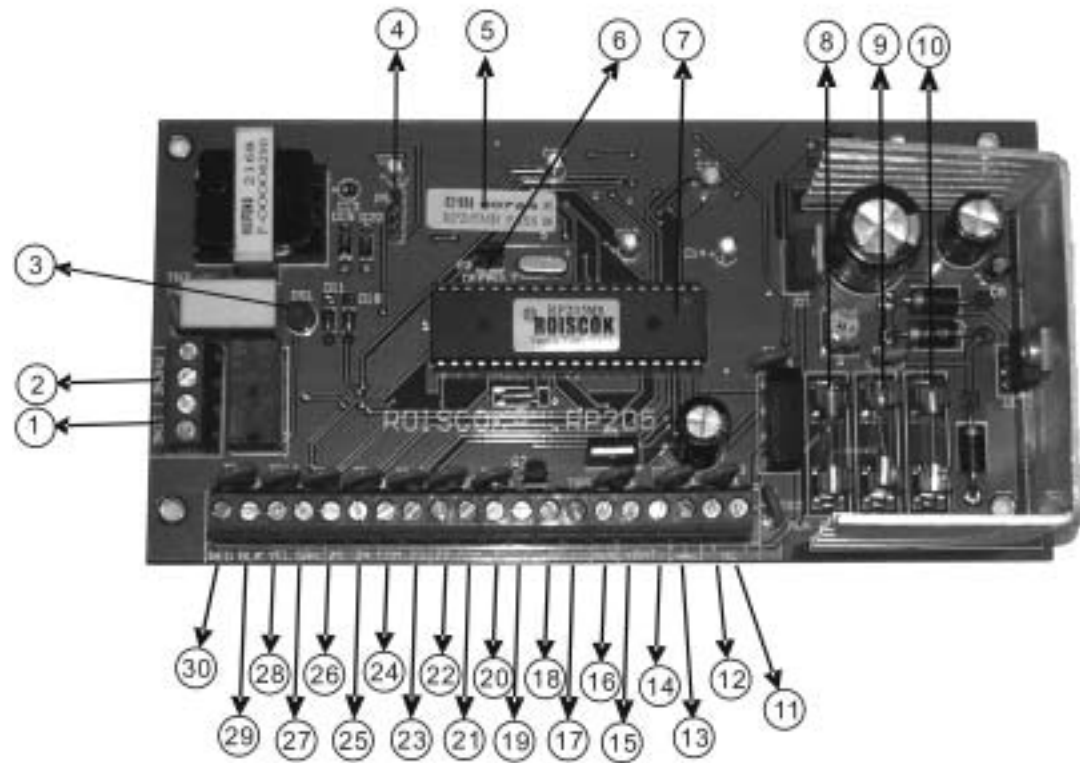

Fig.2 DSM205MB

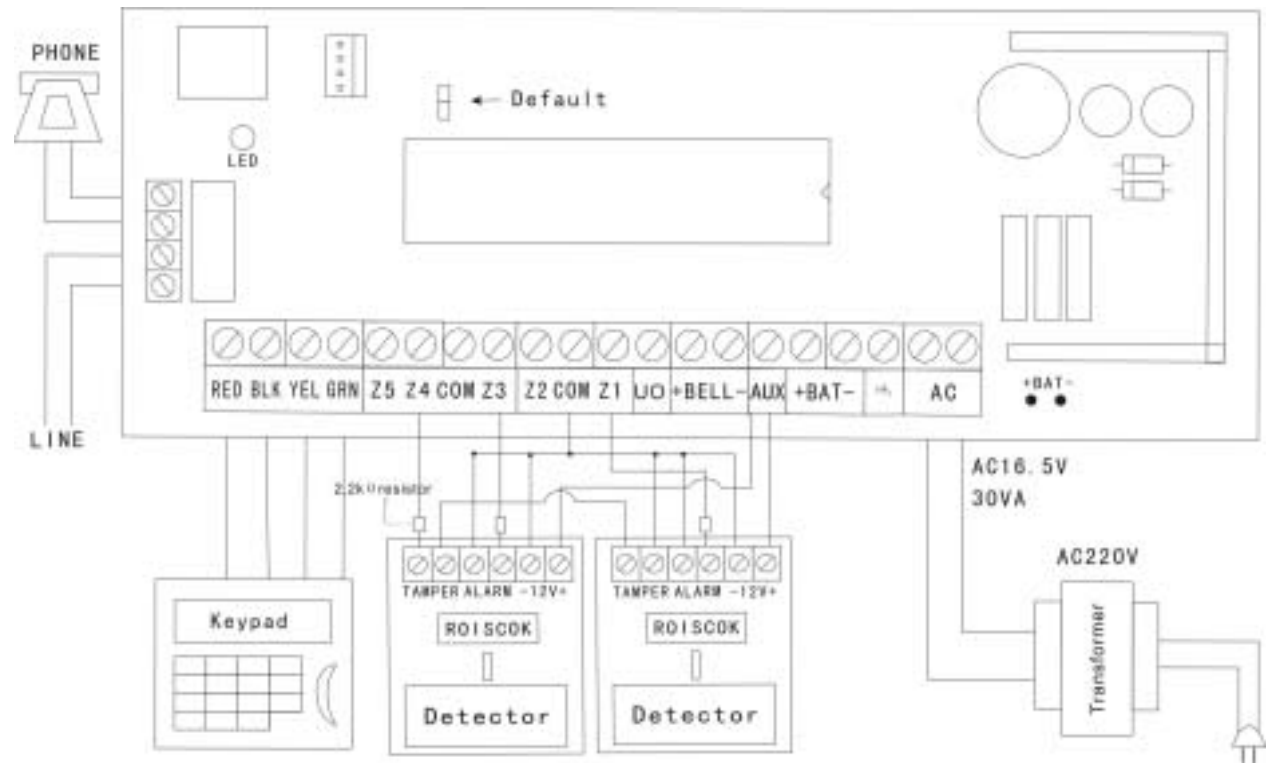

Fig.3 Connection Instruction

Install Control Panel and Keypad

The DSM-205 control panel should install in the aridity, near by AC power supply which can't be power off and connect the ground well and be easy to connect the phone line. Use correct tool, avoiding the damage toward the equipments.

The keypad is generally installed in the open side of the entry, the height should be easy to user. The Tamper Button on the back cover of the keypad can prevent the keypad from being broken or tore down, turn on it and press it tightly to the wall while installing.

Please connect the 4 lines of the keypad with the main board respectively according to the red, black, yellow and green sequence. Such as Fig.3 shows.

Connect the Telephone Line

There are two twin ports of telephone lines on the mainboard. The ports which mark LINE used for input, PHONE for telephone. Such as Fig.3 shows.

Connect the Standby Battery

Please provide a standby battery (DC12V) inside to panel in case of the AC power is cut off.

Two lines marked BAT link the battery with anode+ (red) and the cathode -(black) respectively. Such as Fig.3 shows.

Don't conjunction any power before connected all the lines well.

Connect Transformer

The output of transformer should be AC16.5V, connecting into the AC two ports on the mainboard. When AC power is different, please carefully choose a right transformer to be applicable to AC220V or perhaps AC110V. Remember: The red lines for the high -voltage, do not mix with blue which is the low-voltage.

Don't power the system before the installation finished well.

Connect Siren

The port BELL is used for connect siren. Please watch for cathode and anode when connecting.

Connect Detector(s)

As the Fig.3 shows, the wiring work must be done without power.

1. Used and unused zone should connect with 2.2k Ω termination resistors. When connecting detector, please install termination resistors in the detector, to ensure the system of self-protection function.
2. The two ports of ALARM, one for COM port and another for alarm zone ports respectively on the mainboard.
3. TAMPER ports of detector, connected to tamper zone and COM. When there are many detectors, TAMPER port in series to access tamper zone and COM port.
4. "+ DC12V -" in the detector connect AUX and COM respectively. Do not mix anode and cathode.
5. Please connect the port of UO when need.

Connect Voice Module

As Fig.4, connecting voice module just need to insert it into the connector on the control panel.

- 1(record) - recording button
 - 2(play)-test record button
 - 3 - the eligible label including production serial number, tester number, production type and version number.
 - 4 - recording microphone
-

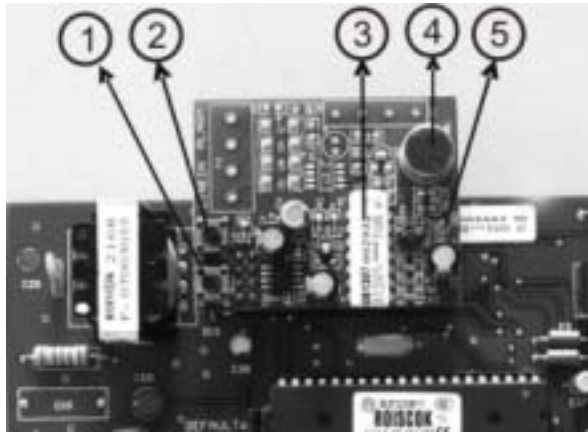

Fig.4 Voice Module

Connect Remote Receiver

When arm or disarm by a remote controller, please programming a zone as switch lock zone. And connect the remote receiver as following:

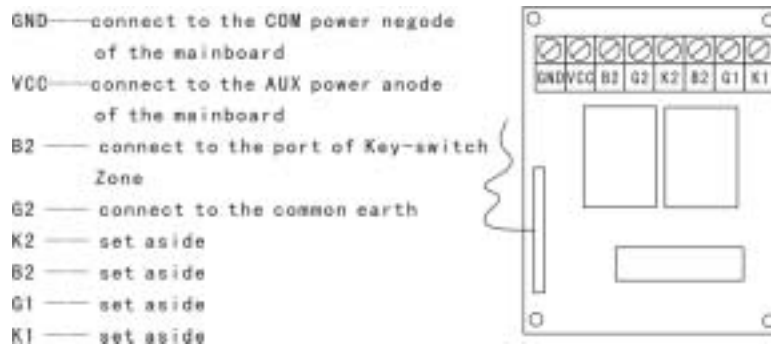

Fig.5 Remote Receiver

Connect Wireless Receiver

The function of the port on RP208EW4 wireless receiver:

1	12VDC Power	11	Zone-1 Indicating Light
2	Set Aside	12	Zone-2 Indicating Light
3	Remote Armed	13	Zone-3 Indicating Light
4	Set Aside	14	Zone-4 Indicating Light
5	Trouble Output	15	Receive Data Indicating Light
6	Zone 1 Connector	16	Interfered
7	Zone 2 Connector	17	Setting Indicating Light

8	Zone 3 Connector	18	Trouble Indicating Light(1)
9	Zone 4 Connector	19	Trouble Indicating Light(2)
10	Dial Switch	20	Touch Switch
		21	Antenna Connector

1. 6-9 are corresponding 1-4 receiver's channels, should be connected 4 of the zones on DSM-208MB
2. The port +12v should connect to AUX on control panel, the GND port to the COM.
3. When using remote controller, the port 3 should connect switch lock zone of DSM-205
4. In normal, the dial 1 and 2 on the dial switch 10 should be set at the position ON.

Please refer to RP208EW4 User's Manual for more details.



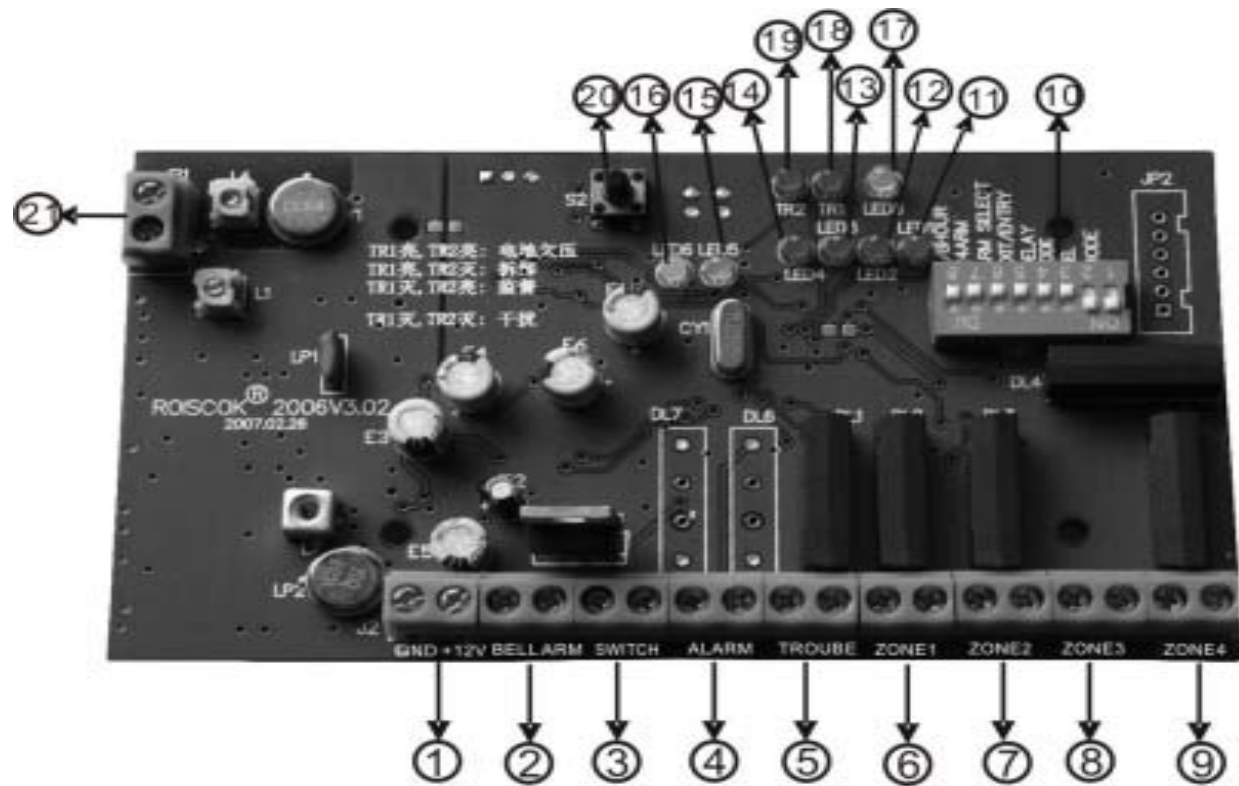

Fig.6 Wireless Receiver (DSM-208EW4)

CHAPTER 4 - FUNCTION AND TECHNICAL DATA

You can communicate your DSM-205 through the Keypads (DSM-205KP). With the Keypad, you can operate your system by arm/disarm, bypass, emergency, closing the siren, inspecting trouble, programming the system and so on.

All of your system's detectors are wired to the control panel. As such, your system always knows the status of any protected door, window, hallway, room, or area.

The main board of DSM-205 is DSM-205MB.

The main features of DSM-205 include the DSM205KP and DSM205MB.

Main Features of DSM-205KP

- LEDs indicate the functions of system
- 3 Keypad Emergency Zones: Panic[1]+[2], Fire[4]+[5], Medical[7]+[8]
- Key-press with Audible Feedback
- System Status Display
- LED Indication: Alarm, Power, Armed, Bypass, Ready, Tamper
- Tamper is Supervised
- Disarm by Code
- Disarm by Remote Controller
- Disarm By Duress Code
- LED Display Bypassing and Not-ready Zones
- Quick Arm
- Quick Arm by Code
- Quick Stay Arm
- Stay Arm by Code
- Bypass zone quickly
- Bypass zone by Code

Main Features of DSM-205MB

Zones

- 5 programmable zones on Main Board
 - Special zones: Zone 4 -tamper Zone (default) and Zone 5 - Fire Zone (default)
-

- 11 types of Programmable Zones, 7 types of Voice Formats
- Zone Terminal: NC, NO, Single End with Resistor 2.2KΩ
- End Calling Function
- Disarm/Arm Report can be set

Siren Driver

- Built-in Siren Driver(750mA)

Clock

- Built-in Digital Clock

Siren Voice Output

- Siren Voice type is Programmable. Current output : 750mA(max)

Built-in Digital Communicator

- Attached Digital Communicator, Compatible with Contact ID , 4+2
- 4 Follow-me Phone Numbers
- 2 Central Station Numbers

Code

- 1 Installation Code
- 1 Master Code, this Code Can Create Duress Code Automatically
- 9 User Codes, Each Code Can Create Duress Code Automatically

Periodic Test

- Offer Testing Report to Alarm Center Automatically Every Day

Peripheral Equipment

- Voice module
- Remote Control, Using for Disarm/Arm and Emergency
- Wireless Receiver

Timing Function

- Auto Daily Arm
- Auto Daily Test report
- Windows Disarm/Arm Report

Monitor Function

- Trouble Data can be Displayed on Keypad, and Also can be Transmitted to Central Station
- Battery in Low Power
- Siren Circuit in Trouble
- AC Supply in Trouble
- System Clock is Not Set
- Tamper Prevention
- Fire Alarm Circuit Trouble

UO Port

- UO port can be activated when the system is Alarm, Arm or Disarm. (Welcome check the location 22 in Chapter 5 for details)

Charging of Standby Battery

- Main Board attaches charging circuit, the Standby Battery can be charged via BAT port

TECHNICAL DATA

Main Board

Input power	16.5VAC 25VA via transformer
Back-up Battery	DC12V 4Ah, or DC12V 7Ah
Auxiliary Power	12VDC 400mA maximum
Siren port output	12VDC 750mA maximum
Programmable output	Open collector Active pull down 70mA max
Switch zone output	250mA
Circuit Response Time	500mS
Fuse AUX	Auxiliary Power 0.5A
Fuse BELL	Bell/LS Power 1A
Fuse BAT	Battery Power 2A
Dimension/weight	80*167mm/0.17kg

Keypads

	LCD Keypad
Current consumption	70mA typical, 90mA max
Control panel connections	4-wire up to 100M from panel
Dimensions	110*130*25mm

CHAPTER 5 – PROGRAMMING DIRECTION

Restoring Factory Defaults

Recover the default of the control panel before program:

1. Connect the keypad and the control panel
2. Check if the line have linked correctly on all the other port
3. Turn off all the power
4. Short circuit the DEFAULT jumper of the mainboard (reference the Fig.2 in page 13)
5. Re-power the system (AC or the standby battery)
6. When you hear a brief sound "beep - ", cut off the DEFAULT. The default has been recovered already.
7. Please check the signal light, when you are in programming mode, the light of READY is flicker.

Program Explain

First confirm the DEFAULT jumper is cut off.

Programming is a process of altering or setting the location data of the control panel, DSM-205 has 91 locations 01-91 for setting data, and each data will correspond to a different function of the control panel. The location are made up of 2 digital, the data of location are made up of 1 digital, 2 digital or many digital. DSM-205 has the advantage of agility and compact in programming, user only have to alter or set part or all the data of location. Not all location need to be set, and most of the location can only use the default data.

Connect the mainboard and the control panel, use the DSM-205KP keypad to program when the power is on.

Check Location Data

Check location data need in the state of program mode. LED display the relative information after enter to the location which need to be checked, but the Code won't display.

It's often necessary to check the data stored in a memory location to be sure it's correct. If improper data is found, it must be corrected in order to obtain the

desired system response. The data in a location can either be a number (from 0-9) or a letter numbering system. For our purposes, the characters A through F will be referred to as hexadecimal digits.

Whenever the installer Programming mode is active, the first 4 keypad's Zone LEDs (1-4) are used to reveal each digit in a LEDs, the contents of any location can be determined. See table below.

	ZONE LEDs			
I.D.	1	2	3	4
Value	8	4	2	1
0	Off	Off	Off	Off
1	Off	Off	Off	ON
2	Off	Off	ON	Off
3	Off	Off	ON	ON
4	Off	ON	Off	Off
5	Off	ON	Off	ON
6	Off	ON	ON	Off
7	Off	ON	ON	ON
8	ON	Off	Off	Off
9	ON	Off	Off	ON
A	ON	Off	ON	Off
B	ON	Off	ON	ON
C	ON	ON	Off	Off
D	ON	ON	Off	ON
E	ON	ON	ON	Off
F	ON	ON	ON	ON

EXAMPLE: Zone 4-ON Zone 3-off Zone 2-off Zone 1-ON TOTAL = 1

EXAMPLE: Zone 4-ON Zone 3-On Zone 2-Off Zone 1-ON TOTAL =B

Hexadecimal Digits

In some locations you may be required to enter hexadecimal digits A-F to do so see the following table.

"A" is entered by pressing **[STAY]+[1]** "B" is entered by pressing **[STAY]+[2]**

"C" is entered by pressing **[STAY]+[3]** "D" is entered by pressing **[STAY]+[4]**

"E" is entered by pressing **[STAY]+[5]** "F" is entered by pressing **[STAY]+[6]**

Check Locations Occupy More Than One Digit with LED Keypad

When a location contains more than one digit, they cannot be viewed simultaneously on the LED Keypad. As soon as a location is accessed, the first digit is displayed automatically. Additional digits (if they exist) can be displayed by pressing the following keys. **[STAY]** **[STAY]** Used to display the next digit in a location containing at least two digits; e.g. if 5-6-7-8 is store in a location, the "5" is displayed first; by pressing **[STAY]** **[STAY]**, the "6" will be displayed; continue this

process to display the entire contents of the chosen location. Error beeps will be produced when it's attempted to display digits which don't exit. **STAY ARM** Used to move backwards among the digits stored in a location containing at least two digits. Error beeps will be produced when it's attempted to display digits which don't exit.

ENTRY/EXIT Program

According to the operation as below, you can enter into or exit the program state, check location data, change the location data and so on

1. Enter into program mode: pres [#]+[master code]
2. Enter into the appointed location: [enter 2 digital location No.]+[ARM]
3. Enter into the next location: press [ARM]
4. Change location data: change the location data, press [#] to affirm. The keypad will make a long sound "beep—" to show operating right, "beep, beep, beep" short sound show operating wrong.
5. Exit programming mode: input the master code +[ARM]

A Programming Tutorial

To get acquainted with some programming basics, a short tutorial has been prepared. It involves changing the Installer Code from the factory default of 0-2-0-6 to a sequence of you own choosing. If you can master this operation, subsequent programming should be easy.

	Operation	Action	Comments
1	Enter the Programming Mode	Enter the factory default Installer Code : [#][0205]	A long beep will sound, confirming successful entry into Installer Programming.
2	Access the Installer Code(stored in Location"08")	Press[0][8][ARM]	No confirming beep
3	Enter a unique Installer Code (for this tutorial, we'll use 5-6-7-8)	Enter[5][6][7][8]	No confirming beep
4	Store the data you have entered	Press[#]	A long beep will sound confirming that data has been properly stored if a wrong number of digits entered three (error) beep

			will sound after pressing [#]
5	Check the data stored in Location"08"	The LED display [5].Press [STAY][STAY] check the next	[5678]
6	Go to another location of your choice	Press the desired two-digit location and [ARM]	Press[ARM] along to go to the next sequential location
7	Exit programming	Enter your Installer Code and press [ARM]	A long beep will confirm your actions

Data In the Location

General System Parameters: Locations 00-07

Location: 01	Preparation	Default: 00
---------------------	--------------------	--------------------

Location: 02	the First Central Station phone number

Explain: To input or alter the phone number is required to enter the location and input the telephone number and then press [#] to store it. Up to 20 digits can be entered to the location.

To delete an existing phone number, just press the Key [#].

Location: 03	the Second Central Station phone number

Same as in Location 02

Location: 04	Preparation
---------------------	--------------------

Location: 05	User's No.	Default: 0000
---------------------	-------------------	----------------------

PURPOSE: to assign the system's Central Station Account Number.

Hexadecimal account numbers (those using 0 through 9 and A through F) are accepted by DSM-205. Use the key combinations below to enter hexadecimal digits "A" through "F"

Hex digit	Press
A	[STAY], 1
B	[STAY], 2
C	[STAY], 3

Hex digit	Press
D	[STAY], 4
E	[STAY], 5
F	[STAY], 6

Acct No.			

"0" will not send a digit to the central station, to send "0" use "A" digit

Location: 06	Preparation
---------------------	--------------------

Location: 07	Preparation
---------------------	--------------------

Installer Code : Location 08-10

Location: 08	Installer Code I					Default: 0205
---------------------	-------------------------	--	--	--	--	----------------------

The installer code used by installer authorized to modify the system's parameters. It is recommended to change the "factory default" Installer Code to one of your own choice. It is made up by 4 digits. **Default : 0205**

Location: 09	Installer Code II					Default: 1205
---------------------	--------------------------	--	--	--	--	----------------------

Same as the Installer Code 1, but with a few limitations: It can't modify the "default code", observe and modify the first installer's codes, modify any phone number, nor observe & modify MS lock code.

Location: 10	Master Code					Default: 1234
---------------------	--------------------	--	--	--	--	----------------------

PUPROSE: to establish the keypad code for the system's "chief user"; the Master Code provides the following special privilege:

1. Alter the master code and users' code
2. Setting the clock ;
3. Checking the trouble and the events record or other operation
4. System testing ;
5. Set follow-me phone number

Note: the Master Code cannot be seen through the keypad.

System Time : Locations 11-13

Location: 11	Exit Delay	Default: 030
---------------------	-------------------	---------------------

Location 11 is used to set the time of exit delay, which unit is second. The time of delay is made up of 3 digits, 1 second at least, 255 second at most. For example, 030 means the delay time is 30 seconds. When arm, it won't alarm to leave the

locale in the time of exit delay.

Location: 12	Entry Delay	Default: 030
---------------------	--------------------	---------------------

Location 12 is used to set the time of enter delay between 001 and 255. For example, 030 means the delay time is 30 seconds. When enter into the locale, it won't alarm to disarm in the time of enter delay.

Location: 13	Bell cutoff Time	Default: 03
---------------------	-------------------------	--------------------

Location 13 is used to set auto alarm time of the External Sounder, before it shuts down automatically. Enter the number of minutes between 01 and 90

Intrusion Zone Types and Zone Sounds : Locations 14-18

Locations 14 through 21 are identical and are corresponding to Zone 1 through 8 respectively. Each of these locations contains two digits. The first digit is used to set the type of the zone, the second digit is used to set the type of the sound. Attention: Each zone must be connected to an EOL 2.2K Ω resistance when installing, even if the zone not in used.

1stDigit	Zone Type and comment of Zone 1-5
0	Not Used All unused zones should be given this designation. It is also used to disable a zone
1	Enter/Exit Delay If violated, a zone with this designation will not cause an intrusion alarm during the Entry and Exit Delay periods.
2	Instant(Intrusion) Causes an immediate intrusion alarm if violated when the system is in arm state.
3	Entry Follower A zone(s) given this designation will cause an immediate intrusion alarm when violated unless an Entry/Exit zone was violated first if so, an Entry Follower zone(s) will remain bypassed until the end of the Entry Delay period.
4	Interior + Entry Delay Follower If the system is armed to AWAY (ARM) mode: this type of zone behaves like the Entry Follower, described above If the system is armed to the STAY mode: this type of zone will be bypassed.

5	<p>Fire Zone Intended for smoke or other types of fire detectors. If violation, will cause an immediate fire alarm, regardless of the system's armed/disarmed state. Suggest Zone 5 can be programmed as a fire zone. A fault in the wiring of any fire zone, if supervised, will cause a fire alarm , manifested by a rapid flashing of the keypad's Fire LED.</p>
6	<p>Tamper Zone If violation, will cause an immediate tamper alarm, regardless of the system's armed/disarmed state. Suggest Zone 6 on DSM-205 to be a Tamper Zone.</p>
7	<p>Panic Zone If violated an immediate panic alarm will be announced , regardless of the system's armed /disarmed state.</p>
8	<p>Key-switch Zone-Instant If desired for system arming and disarming an external SPST spring-loaded, normally open, momentary type key switch can be added. The key switch permits an instant disarming of the system after tripping. And when arming the system an exit delay will follow.</p>

2 nd Digit	Zone sound and comments of Zone 1-8
0	<p>Silent A violation during the armed period will produce no sound. The resulting alarm can still be reported to the Central Station</p>
1 (default)	<p>External sounder (continuous) Cause the external sounding device to annunciate steadily, without breaks in the sound cadence the sound will continue until the sounder "times out" or the system is disarmed</p>
2	<p>External sounder (pulses) Cause the external sounding device to produce a pulsed (of staggered) annunciation this sound is usually recommended for fire alarm annunciation.</p>
3	<p>Keypad sounder Only Cause the piezo sounder within the system's keypad(s) (only) to beep rapidly</p>
4	<p>External sounder +Keypad Sounder Causes the external sounding device to annunciate continuously, without breaks in the sound cadence causes the piezo sounder within the system's keypad(s) to beep rapidly</p>
5	<p>External Sounder When Armed/keypad Sounder When Disarmed Related to 24H Zones. When alarm during disarm, the keypad's buzzer will be activated When alarm during armed system, the external sounder will be activated.</p>

6	<p>Door Chime Assigned to an opening which, when violated during the disarmed, will cause the system's keypad(s) to beep once during an alarm, the external sounding device will annunciate continuously, without interruption. When alarm occurs during armed system only the external sounder will be activated.</p>
----------	---

For example :if the zone 1 need to set to be entry/exit delay zone, and need the exterior alarm intermittent sound at the same time keypad buzzer sound when need to alarm, then input 14 in location 14. If the 3 zone need to set to be active zone, and need the exterior alarm intermittent alarm, then input 32 in locate 16. The zone characteristic of default:

Zone 1: Entry/Exit Delay Zone; zone type is 11

Zone 2: Instant (Intrusion) Zone; zone type is 21

Zone 3: Panic Zone; zone type is 70

Zone 4: Tamper Zone; zone type is 61

Zone 5: Fire Zone; zone type is 52

Special Zones Suggestion:

- a. Zone 5 is reserved as a Fire Zone, Supports Smoke Detectors and/or Gas Detectors. A fire zone cannot be disabled or bypassed. For fire zone the recommended (default) zone sound is "External sounder pulsed". However it is possible to change the zone sound and type to any of the ones provided in the previous list.
- b. Urgency zone alarm doesn't result the siren sound but calling to the CMS or follow-me numbers.
- c. Zone 4 on the DSM-205 is reserved as a Tamper Zone. This zone can be programmed to any zone type. If the zone was programmed as Tamper, in violation, a Tamper Code report will be sent and the Tamper LED on the keypad will light up.

Utility Outputs- Event and Result : Locations22, Default 00

The DSM-205 supports one open collector Utility Output (derived between the UO/ECL and AUX terminals) which can be used for switching an external device on or off. Once the Utility Output is activated the device will be connected between AUX (+12V) and ground (0V). This connection is capable of switching

light loads of no more than 70mA.

When input different data in locate 22, UO will active in different way.

Digit	Event and Result
00 (default)	Not Active UO offers no response to any system activity UO
01	preparation
02	Arm Follow (Latch) UO is activated when the system is armed. The activation occurs after the expiration of the exit/delay period. The UO remains active (latched) while the system is armed. When disarming the system the UO deactivates (Unlatches).
03	Arm Follow (Pulse) UO is activated when the system is armed .The activation occurs after the expiration of the exit/delay period. The UO is activated for several seconds (pulse), after which is deactivated.
04	Alarm Follow (Latched) UO is immediately activated when the system goes into any type of alarm (i.e. intrusion, fire, keypad-initiated panic) UO remains active (latched) for the duration of the alarm-even after the system's sounder "times out" UO is deactivated when the system is disarmed.
05	Alarm Follow (Pulse) UO is immediately activated of several seconds and then deactivated whenever the system goes into any type of alarm (i.e. intrusion, fire, keypad-initiated panic)
06	Panic Follow (Latched) UO is activated immediately when a PANIC alarm is triggered by a violation of a zone, defined as Panic, or by pressing the keypad's [1] and [2] keys simultaneously for two seconds. UO is deactivated when the system is disarmed.
07	Panic Follow (Pulse) UO is activated for several seconds when a PANIC alarm is triggered by a violation of a zone, defined as Panic, or by pressing the keypad's [1] and [2] keys simultaneously for two seconds.
08	Fire Keying Follow (Latched) UO is activated immediately when a Fire alarm is triggered by a violation of zone 5, defined as Fire, or by pressing the keypad's [4] and [5] keys simultaneously for two seconds, UO is deactivated when the system is disarmed.
09	Fire Keying Follow (Pulse) UO is activated when a Fire alarm is triggered by violation of zone 5, defined as Fire, Or by pressing the keypad's [4] and [5] keypad's simultaneously for two seconds.
10	Special Emergency Keying Follow (Latched) UO is activated immediately when pressing the keypad's [7] and [8] keys simultaneously for two seconds. UO is deactivated when the system is disarmed.

11	Special Emergency Keying Follow (Pulsed) UO is activated for several seconds when pressing the keypad's [7] and [8] keys simultaneously for two seconds.
12	Duress Code Follow(Pulse) UO is activated for several seconds (and then deactivates) when any duress code is entered.
13	Duress Code Follow (Latched) UO is activated when any duress code is entered.
14	AC Loss Follow (Latched) UO is activated due to a lack of power from the commercial AC. UO is deactivated when the system is operating properly from commercial (AC) power.
15	AC Loss Follow (Pulse) AC UO is activated for several seconds (and then deactivates) due to a lack of power from the commercial AC.
16	Low Battery Follow (Latched) UO is activated due to low power from the backup battery. UO1 is deactivated when the battery is in good condition.
17	Low Battery Follow (Pulse) UO is activated for several seconds due to low power from the backup battery.
18	Zone 1 Alarm Follow (Latched) UO is immediately activated when an alarm occurs on Zone 1. UO remains active (latched) for the duration of the alarm-even after the system sounder "times out". UO is deactivated when Zone 1 goes into normal condition.
19	Zone 1 Alarm Follow(Pulse) UO is immediately activated for several seconds (pulse) and then deactivates whenever Zone 1 goes into alarm.
20	Zone 2 Alarm Follow(Latched)
21	Zone 2 Alarm Follow(Pulse)
22	Zone 3 Alarm Follow(Latched)
23	Zone 3 Alarm Follow(Pulse)
24	Zone 4 Alarm Follow(Latched)
25	Zone 4 Alarm Follow(Pulse)
26	Zone 5 Alarm Follow(Latched)
27	Zone 5 Alarm Follow(Pulse)

Communication Parameters : Locations26-29

Locations 26 and 27 allow you to define the manner in which the DSM-205 communicates with the Central Station when it reports alarms, Restores, troubles, openings/closings, and tests.

Digital Communicator Controls : Locations 26, Default 41

- First digit: determines the number (or hexadecimal digit) corresponding to

the Dialing Method/Duty Cycle /Redial Time desired

- Second digit: determines the number corresponding to the Attempts /Answering Machine Use /UL Installation
- Attempts: Attempts sets the Number of times the control panel will redial the Central Station after failing to establish a successful communication,
- Voice Module: If enabled ("YES") voice messages will be sent. If "NO" then tones will be used to represent an active alarm.

Location: 26		Dialer Controls:(1 st Digit)	
1Digit	Dialing Method	Duty Cycle	Redial Central Station
1	Pulse @20 pps	67/33	After 30 seconds
2	Pulse @10 pps	67/33	After 30 seconds
3	Pulse @10 pps	61/39	After 30 seconds
4 (default)	DTMF	N/A	After 30 seconds

Location: 26		Dialer Controls: (2Digit):	
2Digit	Attempts	Voice Module	
0	8	No	
1 (default)	3	No	
8	3	Yes	
9	8	Yes	

Central Station Protocols : Location 27, Default: 00

To understand and modify the Code format according to a specific central station see the following

- **First digit:** determine the number corresponding to the desired combination of: Kiss-off/ Handshake Freq/ Message Validation/ Extended-Non-Extended Format
- **Second digit:** determine the number (or letter) corresponding to the desired Combination of: Dialing Rate/ Inter digit Time /Date Frequency

Location: 27		CS Protocols: (1 st Digit)	
1 st Digit	Format	Kiss-off/Handshake Freq	Message Validation
0(default)	Non-Extended	1400Hz	Dual Round Compare
1	Non-Extended	2300Hz	Dual Round Compare
2	Non-Extended	1400Hz	Parity
3	Non-Extended	2300Hz	Parity

4	Extended 扩展	1400Hz	Dual Round Compare
5	Extended	2300Hz	Dual Round Compare
6	Extended	1400Hz	Parity
7	Extended	2300Hz	Parity

Location:27		CS Protocols:(2 nd Digit)	
2 nd Digit	Date Rate	Inter digit Time	Date Frequency
0(default)	40 pulses/sec	390ms	1800Hz
1	33 pulses/sec	390ms	1800Hz
2	20 pulses/sec	390ms	1800Hz
3	10 pulses/sec	390ms	1800Hz
4	40 pulses/sec	650ms	1800Hz
5	33 pulses/sec	650ms	1800Hz
6	20 pulses/sec	650ms	1800Hz
7	10 pulses/sec	650ms	1800Hz
8	40 pulses/sec	390ms	1900Hz
9	33 pulses/sec	390ms	1900Hz
A	20 pulses/sec	390ms	1900Hz
B	10 pulses/sec	390ms	1900Hz
C	40 pulses/sec	650ms	1900Hz
D	33 pulses/sec	650ms	1900Hz
E	20 pulses/sec	650ms	1900Hz
F	10 pulses/sec	650ms	1900Hz

Format Name	(PPS) pulses/sec	Kiss off/ Handshake	Validation	Inter Digit Time	Code Format
Silent Knight/ADEMCO Slow	10	1400Hz	Dual round	650	0F
Silent Knight/ADEMCO Slow Extended	10	1400Hz	Dual round	650	4F
Radionics /DCI/Franklin Slow	10	2300Hz	Dual round	650	17
Silent Knight Fast	20	1400Hz	Dual round	650	0E
Silent Knight Fast Extended	20	1400Hz	Dual round	650	4E
Sescoa / Franklin/ Vertix/DCI Extended	20	2300Hz	Dual round	650	56
Universal high speed	20	2300Hz	Dual round	390	12
Radionics	20	1400Hz	Dual round	390	02

Radionics	20	2300Hz	Dual round	390	12
Radionics Extended	20	1400Hz	Dual round	390	42
Radionics Extended	20	2300Hz	Dual round	390	52
Radionics	40	1400Hz	Dual round	390	00
Radionics	40	2300Hz	Dual round	390	10
Radionics Extended	40	1400Hz	Dual round	390	40
Radionics Extended	40	2300Hz	Dual round	390	50
Radionics	40	1400Hz	Parity	390	20
Radionics	40	2300Hz	Parity	390	30
Radionics Extended	40	1400Hz	Parity	390	60
Radionics Extended	40	2300Hz	Parity	390	70

CS Protocols: Location 28, default: 13

When selecting 01 (the contact ID) format, all the reporting codes will be automatically applied to the locations of the reporting codes.

When selecting 03 (the Pulsed Protocol) the default for all the reported codes will be "00" and any other code should be entered manually follow the CMS software.

Digit	Format Name	Inter-digit Time	Date Frequency
01	Contact ID	NA	NA
03(default)	4+2		

Location: 29	Preparation	
---------------------	--------------------	--

System Controls : Location 30, Default 13

Location 30 allows you to specify some additional parameters, which determine how the control panel will operate. The location contains two digits.

Comments on system controls (Location 30:1stDigit)

Quick Arm: Eliminates the need for entering a User Code when arming to the STAY or AWAY modes. Simply pressing [STAY] or [ARM] will arm the system to the respective mode

Loudspeaker/Bell-Siren: Select **Loudspeaker** if the external sounder(s) NOT equipped with a built-in sound driver; doing so causes the panel to produce an oscillating frequency for the device, select **Bell/Siren** if the external sounder(s) is

a bell or a buzzer or equipped with a built-in electronic sound driver

Quick Bypass: Eliminates the need to enter a User Code when bypassing a zone.

Silent Panic: If "NO", the panic alarm will be AUDIBLE at the External Sounder and visual on the keypad. If "YES", the panic alarm will be INAUDIBLE at the External Sounder and invisible on the keypad and there will be no audible kiss-off.

Bell Squawk On Arming: If selected, Bell Squawk on Arming will produce a brief confirmation "chirp" from the system's external sounder(s) once the system is armed and the Exit Delay expires.

3 Minute Bypass Enabled: If selected, 3-Minute Bypass Enabled bypasses all zones automatically for 3 minutes when power is restored to an "un-powered" system-to prevent potential false alarms by allowing time for the stabilization of motion and/or smoke detectors.

- **First digit:** determine the number(or letter)corresponding to the choices involving Quick Arm/Quick Bypass/Loudspeaker/Bell-Siren
- **Second digit:** determine the number (or letter)corresponding to the use of silent Panic/Bell Squawk on Arming /3 Minute Bypass

Location:30	System Controls: (1 st Digit)		
1 st Digit	Loudspeaker/Bell-Siren	Quick Bypass	Quick Arm
0	Bell-Siren	NO	YES
1(default)	Bell-Siren	YES	YES
4	Bell-Siren	NO	YES
5	Bell-Siren	YES	YES
8	Loudspeaker	YES	NO
Location:30	System Controls:(2 nd Digit)		
2 nd Digit	3 Minute Bypass	Silent Panic	Bell Squawk On Arm
0	Enabled	NO	NO
1	Enabled	YES	NO
2	Enabled	NO	YES
3(default)	Enabled	YES	YES
4	Disabled	NO	NO

Periodic Test Time : Location 31

If desired, the DSM-205 can send a daily test transmission to the Central Station to Verify the operation of the Unit's Digital Communicator.

Location:31	Periodic Test Time	Default: 0000
--------------------	---------------------------	----------------------

Sets a fixed, daily time for sending an test transmission to the Central Station. The chosen time is expressed in 24-Hour format (following examples): 8:30 AM=0830 11:15AM=1115, 4:30 PM=1630 If desired, disable the test transmission capability by accepting (or entering) the default (0000)

Note: Failure to set the systems' time clock, will prevent the code from being sent to the Central Station.

Communicator Reporting Codes : Locations 32-91

The reporting codes is a report when the system has something happened to give a report to the alarm center. Different status will send different report.

Reporting Codes for Alarm Events:

To program the codes that will be transmitted by the DSM-205 to the Central Station.

To prevent the corresponding event from being reported, use a "double-zero"(00, the default) in the location.

Notes on Alarm Restores:

An DSM-205 Restore Report informs the Central Station that the external sounder's operation, initially triggered by the respective alarm condition, has either "timed out" or been silenced by the act of system disarming. Be sure to check with Central Station personnel if restore are permitted and, if so, what codes are required.

Annotate: When the communicate protocol is CID, separated codes is the same as restore codes(ABC), input the last 3 digit: OABC;

When the communicate protocol is4+2, the first 2 digit are separated reporting codes(AB), the last 2 digit are restore reporting codes(CD), total are 4 digit:

ABCD

Hex date fast operation A=[STAY]+[1] B=[STAY]+[2]
 C=[STAY]+[3] D=[STAY]+[4]
 E=[STAY]+[5] F=[STAY]+[6]

Location	Description	Num	Digit	Report Code
32	Zone 1 Alarm Reporting code		3	000
33	Zone 2 Alarm Reporting code		3	000
34	Zone 3 Alarm Reporting code		3	000
35	Zone 4 Alarm Reporting code		3	000
36	Zone 5 Alarm Reporting code		3	000
37	Prepare		3	000
38	Prepare		3	000
39	Prepare		3	000
40	Keypad Fire Alarms Reporting code		3	000
41	Keypad Panic Reporting code		3	000
42	Keypad Special Emergency Reporting code		3	000
43	Zone 1 Restore code		3	000
44	Zone 2 Restore code		3	000
45	Zone 3 Restore code		3	000
46	Zone 4 Restore code		3	000
47	Zone 5 Restore code		3	000
48	Prepare		3	000
49	Prepare		3	000
50	Prepare		3	000
51	Keypad Fire Restore code		3	000
52	Keypad Panic Restore Code		3	000
53	Keypad Special Emergency Restore Code		3	000
54	User 0 arm (the "Master" Code, "Quick Arm" OR "Keyswitch" Arm)0		3	000
55	User 1 arm Reporting code		3	000
56	User 2 arm Reporting code		3	000
57	User 3 arm Reporting code		3	000
58	User 4 arm Reporting code		3	000
59	User 5 arm Reporting code		3	000
60	User 6 arm Reporting code		3	000
61	User 7 arm Reporting code		3	000
62	User 8 arm Reporting code		3	000
63	User 9 arm Reporting code		3	000
64	User 0, disarm Reporting code (Key switch disarm)		3	000
65	User 1, disarm Reporting code		3	000

66	User 2, disarm Reporting code		3	000
67	User 3, disarm Reporting code		3	000
68	User 4, disarm Reporting code		3	000
69	User 5, disarm Reporting code		3	000
70	User 6, disarm Reporting code		3	000
71	User 7, disarm Reporting code		3	000
72	User 8, disarm Reporting code		3	000
73	User 9, disarm Reporting code		3	000
74	Auto ARM report code		3	000
75	Forced arm (when the system is armed with a bypassed zone) Reporting code		3	000
76	Stay arm when the system is armed to the Stay (At Home mode) Reporting code		3	000
77	Duress Disarm		3	000
78	Daily test Report Code sent everyday at the time specified in Location 24		3	000
79	Low Battery Reporting code		3	000
80	Loss of AC Power(for at least 15 min) Reporting code		3	000
81	Fire zone trouble Reporting code		3	000
82	Bell Loop Interrupted Reporting code		3	000
83	Low Battery restore Reporting code		3	000
84	Loss of AC Power restore Reporting code		3	000
85	Fire zone trouble restore Reporting code		3	000
86	Bell Loop Restored Reporting Code		3	000
87	Zone 1 Bypass / Restore Reporting code		4	ABCD
88	Zone 2 Bypass / Restore Reporting code		4	ABCD
89	Zone 3 Bypass / Restore Reporting code		4	ABCD
90	Zone 4 Bypass / Restore Reporting code		4	ABCD
91	Zone 5 Bypass / Restore Reporting code		4	ABCD

DSM-205 Control Panel Contact ID reporting codes			
Event reporting	Contact ID		
Zone alarm/unarm		Report code	
Entry/exit alarm		134	
Entry/exit Restore		134	
Panic alarm		130	
Panic Restore		130	
24 hours zone alarm		133	
24 hours zone Restore		133	
Tamper zone alarm		137	
Tamper zone Restore		137	
Smoke induce zone alarm/Restore		111	
Fire zone alarm/Restore		112	
Waterproof zone alarm/Restore		113	
High temperature zone alarm		114	
High temperature zone Restore		114	
Pipeline zone alarm/Restore		116	
Fire zone alarm/Restore		117	
Warning sound alarm		122	
Warning sign alarm		123	
Perimeter zone alarm/Restore		131	
Interior zone alarm/Restore		132	
Daytime/nights zone alarm/Restore		135	
Open zone alarm/Restore		136	
System zone alarm/Restore		140	
Detector tamper zone alarm/Restore		144	
24 hours zone alarm/Restore		151	
gas-fired alarm		151	
gas-fired alarm Restore		151	
Low temperature zone alarm/Restore		152	
temperature dissipate alarm/Restore		153	
Liquid leak alarm		154	
Liquid leak Restore		154	
Oil leak alarm/Restore		155	
Gas leak alarm/Restore		157	
High temperature alarm/Restore		158	
temperature dissipate alarm/Restore		159	
Airflow unsteady alarm		161	

special function				
urgency key-press alarm		100		
urgency key-press Restore		100		
Fire zone alarm		110		
Fire zone Restore		110		
Fire key-press alarm		115		
Fire key-press Restore		115		
Medical treatment emergency alarm		120		
Medical treatment emergency Restore		120		
menace alarm		121		
Menace Restore		121		

Fault reporting				
AC fault		301		
AC Restore		301		
Battery power low		302		
Battery power Restore		302		
Warning sign fault		321		
Warning sign Restore		321		
Fire zone fault		373		
Fire zone Restore		373		

On/off reporting				
User arm	6A	401		
User unarm	6A	401		
User 0 quick arm/unarm	62	408		
Force arm	63	574		
periodic test	64	602		

DSM-205 Installer Programming Worksheet	Customer _____
	Address _____
Customer Phone No:() _____	City_____ State_____ Zip_____
Central Station Account No: _____	Date of Installation:_____
Comments _____	Installer(s): _____
	Comments: _____

Location	Description	Entry	Remark
01	Preparation		
02	Phone No. CS 1		
03	Phone No. CS 2		
04	Preparation		
05	CS Account No.		
06	Preparation		
07	Preparation		
08	Installer Code 1		
09	Installer Code 2		
10	Master Code		
11	Exit Delay		
12	Entry Delay		
13	Bell cutoff Time		
14	Zone 1 Settings		
15	Zone 2 Settings		
16	Zone 3 Settings		
17	Zone 4 Settings		
18	Zone 5 Settings		
19	Zone 6 Settings		
20	Zone 7 Settings		
21	Zone 8 Settings		
22	Utility Output		
23	Preparation		
24	Preparation		
25	Preparation		
26	Dialer Controls		
27	CS Protocols 1		
28	CS Protocols 2		
29	Preparation		
30	System Controls		
31	Periodic Time Set		
32	Zone 1 Alarm		
33	Zone 2 Alarm		
34	Zone 3 Alarm		
35	Zone 4 Alarm		
36	Zone 5 Alarm		

37	Preparation		
38	Preparation		
39	Preparation		
40	Keypad Panic Alarm		
41	Keypad Fire Alarm		
42	Keypad SP Alarm		
43	Restore Code Zone 1		
44	Restore Code Zone 2		
45	Restore Code Zone 3		
46	Restore Code Zone 4		
47	Restore Code Zone 5		
48	Preparation		
49	Preparation		
50	Preparation		
51	Restore Keypad Fire		
52	Restore Keypad Panic		
53	Restore Keypad Special Panic		
54	User 0 Arm		
55	User 1 Arm		
56	User 2 Arm		
57	User 3 Arm		
58	User 4 Arm		
59	User 5 Arm		
60	User 6 Arm		
61	User 7 Arm		
62	User 8 Arm		
63	User 9 Arm		
64	User 0 disarm		
65	User 1 disarm		
66	User 2 disarm		
67	User 3 disarm		
68	User 4 disarm		
69	User 5 disarm		
70	User 6 disarm		
71	User 7 disarm		
72	User 8 disarm		
73	User 9 disarm		
74	Auto ARM		
75	Forced arm		
76	Stay Arm		
77	Duress Disarm		
78	Daily test Report		
79	Rpt Code Low Bat		
80	Rpt Code AC Loss		
81	Rpt Code Fire Trouble		
82	Rpt Code Bell Loop		
83	Restore Code Low Bat		

84	Restore Code AC Loss		
85	Restore Code Fire Tbl		
86	Restore Code Bell Loop		
87	Zone 1 Bypass / Restore		
88	Zone 2 Bypass / Restore		
89	Zone 3 Bypass / Restore		
90	Zone 4 Bypass / Restore		
91	Zone 5 Bypass / Restore		

Phone1	
Phone2	
