

**Sivy SA-4340S
Hardware User Manual**

Ultra 320 SCSI to Serial ATA II

Disk Array Systems

Version 1.1

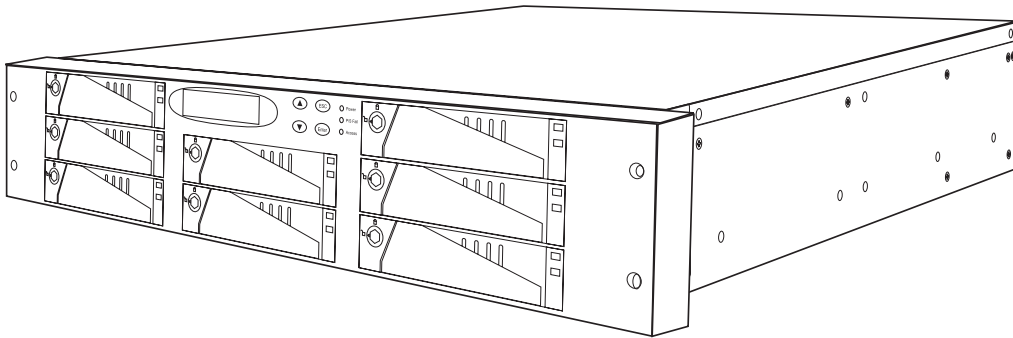

SA-4340S

**Ultra 320 SCSI to Serial ATA II
Disk Array System**

Hardware User Manual

Table of Contents

Preface.....	i
--------------	---

Chapter 1 System Requirements

Operating Environment	1
VT100 Terminal Settings	1
Host Interface	2

Chapter 2 Basic Configuration

Unpacking	3
Components	4
SA-4340S Front Panel	4
Disk Tray	5
SA-4340S Rear View	6
Installing Disks	7
Making Connections	10
Connecting the Host Interface	10
Connecting a network	11
Connecting and Turning on the Power	12

Chapter 3 Maintenance

Replacing a Disk	13
Replacing a Power Supply	14
Upgrading Memory	16

Appendix

Hardware Specifications	19
-------------------------------	----

Preface

About this Manual

This manual is designed to make the disk array system as easy to use as possible. Information contained in this document has been checked for accuracy, but no guarantee is given that the contents are correct. Information and specifications are subject to change without notice.

Copyright Notice

© Copyright 2006 MaxTronic International Co., Ltd.

All rights reserved. This disk array system and related documentation are protected by copyright and are distributed under licenses restricting their use, copying, and distribution. No part of this documentation may be reproduced in any form by any means without prior written authorization of MaxTronic International Co., Ltd. and its licensors, if any.

Conventions



Caution

This symbol is used to remind users to pay attention to important descriptions regarding usage and maintenance (repair) or additional important information related to this disk array system.



Note

This symbol is used to remind users of useful information that can make procedures such as configuration easier to accomplish.

Important Safety Instructions, Care and Handling



Before starting, take a few minutes to read this manual. Read all of these instructions and save this manual for later reference.



Protect the disk array system from extremely high or low temperatures. Let the disk array system warm (or cool) to room temperature before using it.



Protect the disk array system from being bumped or dropped. Do not place the disk array system on an unstable cart, stand, or table. It may fall, causing serious damage to the product.



Keep the disk array system away from magnetic forces.



Do not use the disk array system near water.



Keep the disk array system away from dust, sand, or dirt.



Gaps and openings in the cabinet are provided for ventilation. Never block or cover these openings, because the disk array system may overheat and become unreliable. Don't place the disk array system on a bed, sofa, rug, or other similar surface.



Do not place the disk array system near or over a radiator or other heat source.



Refer to the rating plate for the correct voltage and ensure that the appliance voltage corresponds to the supply voltage.

	<p>The appliance must be grounded. The disk array system is equipped with a 3-wire grounded type of power cord. This power cord will only fit into a grounded type of power outlet.</p>
	<p>If an extension cord or a power center is used with the disk array system, make sure that the total current consumption of all products plugged into the wall outlet does not exceed the ampere rating.</p>
	<p>Do not place the disk array system where the cord will be walked on.</p>
	<p>Never push any kind of object into the disk array system through cabinet gaps and openings, since they may touch dangerous voltage points and cause a risk of fire or electric shock.</p>
	<p>Unplug the power cord from the wall outlet before cleaning. Keep the disk array system dry. Do not use liquid cleaners, aerosol cleaners, or a wet cloth. Use a damp cloth for cleaning.</p>
	<p>Except as specifically explained in this User Manual, do not attempt to service the disk array system by yourself. Opening or removing the covers may expose you to dangerous voltages.</p>
	<p>Unplug this product from the wall outlet and refer servicing to qualified service personnel under the following conditions.</p> <ul style="list-style-type: none"> • If the disk array system has been exposed to water or any liquid. • If the disk array system has been dropped or the cabinet damaged.
	<p>Users should not remove the cover.</p>
	<p>Disconnect all power supply cords before servicing.</p>

Placement Notes



- The disk array system LCD panel can be damaged by exposure to direct sunlight. Limit exposure to subdued or indirect sunlight only.
- The disk array system should be used only in clean environments that are free from airborne contaminants such as dust, dirt, and smoke. Excessive moisture or oil particles in the air can also hinder disk array system performance.
- To reduce the possibility of data errors caused by electromagnetic interference, locate the disk array system at least five feet away from electrical appliances and equipment that generates magnetic fields.

Power Supply Safety Notes



- To avoid electric shocks, do not use an extended power cord or an outlet that does not match the disk array system plug or leaves the plug exposed.
 - The disk array system has a 3-wire grounded plug. The third pin connects to ground; do not remove it.
 - If the power cord or plug is damaged or worn, unplug it immediately and contact a qualified service technician for maintenance.
 - To avoid fire or electric shocks, do not overload electric power outlets.
-

1 System Requirements

Ensure that the following requirements are met before installing the disk array system.

Operating Environment

- 15 cm (6-inches) of space around the disk array system for proper ventilation
- ambient temperature of 5°C to 40°C (40°F to 104°F)
- ambient non-condensing relative humidity of 10% to 85%
- dust, smoke, and oil free environment
- no large magnetic fields, such as those generated by a high voltage power cables and motors, etc.
- no direct sunlight
- a flat, stable surface capable of supporting the disk array system

VT100 Terminal Settings

Refer to the following table for a summary of VT100 terminal settings required to communicate with the disk array system. Refer to your system manual for instructions on setting up the VT100 terminal settings.

Item	Required Setting
Connection	Serial Port (COM1 or COM2)
Protocol	RS232 (Asynchronous)
Cabling	Null Modem cable
Baud Rate	115200
Data Bits	8
Stop Bit	1
Parity	None

Host Interface

The disk array system has dual SCSI interfaces. Refer to the following sections to understand host interface system requirements.

Small Computer Systems Interface

The SA-4340S has dual Ultra320 SCSI interfaces that are compatible with previous SCSI standards. Refer to the following table to understand SCSI bus requirements.



Note

Subtract the internal cable length (30 cm) from the maximum SCSI bus length to calculate the maximum external SCSI cable length.

SCSI Standard	Maximum SCSI Bus Length in Meters	Data Rate in Megabytes per Second	Maximum Number of Devices
Ultra320	12	320	15
Ultra160	12	160	15
Ultra2	12	80	15
Ultra Wide	1.5	40	7
Fast Wide	3	20	15
Ultra	1.5	20	7

2 Basic Configuration

This chapter describes disk array system connections and disk installation.

Unpacking

Contact your supplier if any of the following items are missing or damaged.

Caution



The disk array system is heavy. Be careful when lifting and moving it.

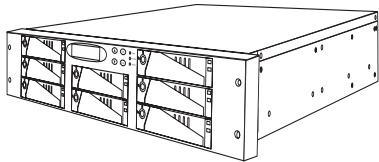

Disk Array System

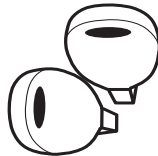

Disk Tray Keys



RS-232 Cable

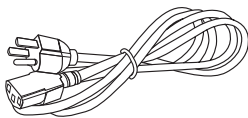

Power Cables



Hardware and software user Manuals

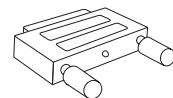

Terminator

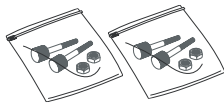

Fix Screw pack M4

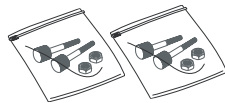

Fix Screw pack UNC #10-32

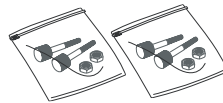

Fix Screw pack M5



Screw pack

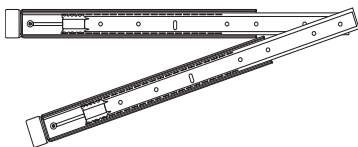

Rails(option)

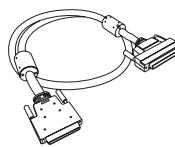

HPD to VHDC Ultra320 SCSI Cable

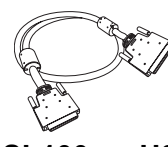

SCSI-100cm U320

Components

SA-4340S Front Panel

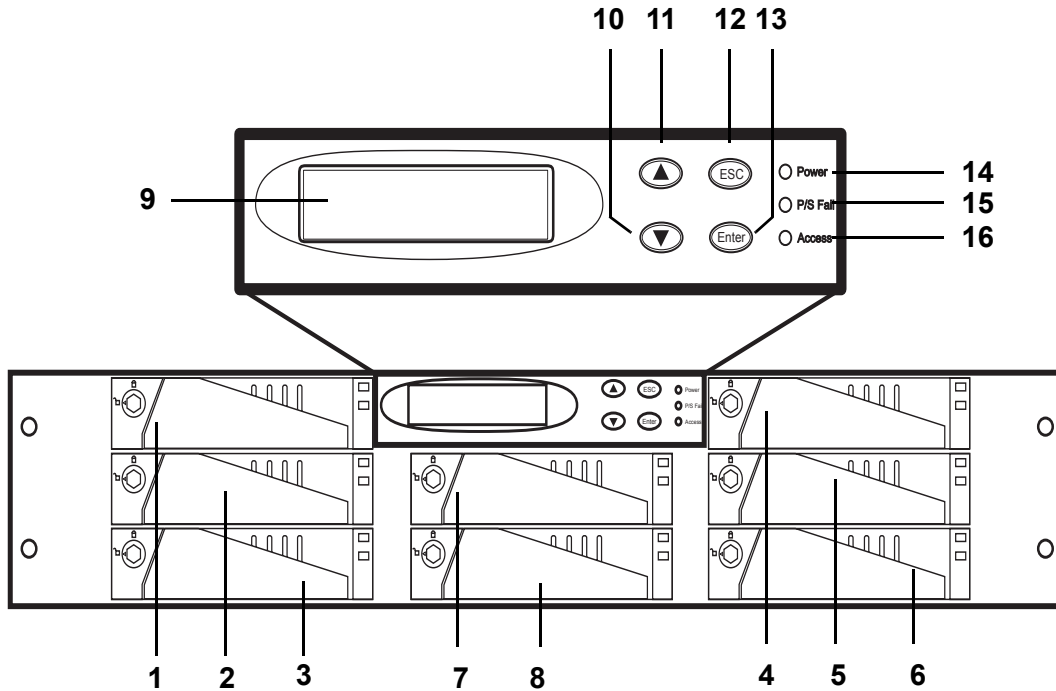

No.	Name	Description
1-8	Disk trays 1 to 8	Removable hot swap disk trays.
9	LCD panel	Displays warning, operating, and configuration information.
10	Down function button	Moves down in the LCD menus.
11	Up function button	Moves up in the LCD menus.
12	Escape function button	Returns to the previous LCD menu without making changes.
13	Enter function button	Selects a menu item or confirms a choice or entry.
14	Power-on indicator (green)	Indicates the disk array system power is on.
15	Power supply fail indicator (red)	Indicates a failed power supply.
16	Host computer access indicator	Indicates data transfer between the disk array system and the host computer.

Disk Tray

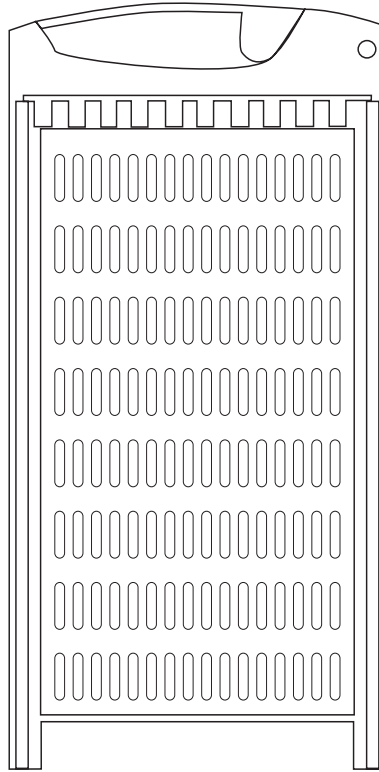

Front

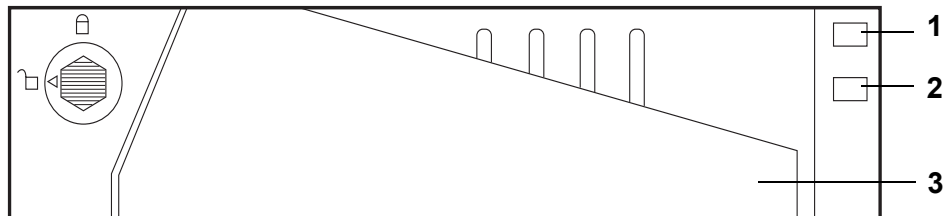

No.	Name	Description
1	Status LED	<ul style="list-style-type: none"> Green-Disk online Red-No Disk
2	Access LED	This blue LED indicates that the disk is being accessed.
3	Tray handle	Releases the disk tray.

SA-4340S Rear View

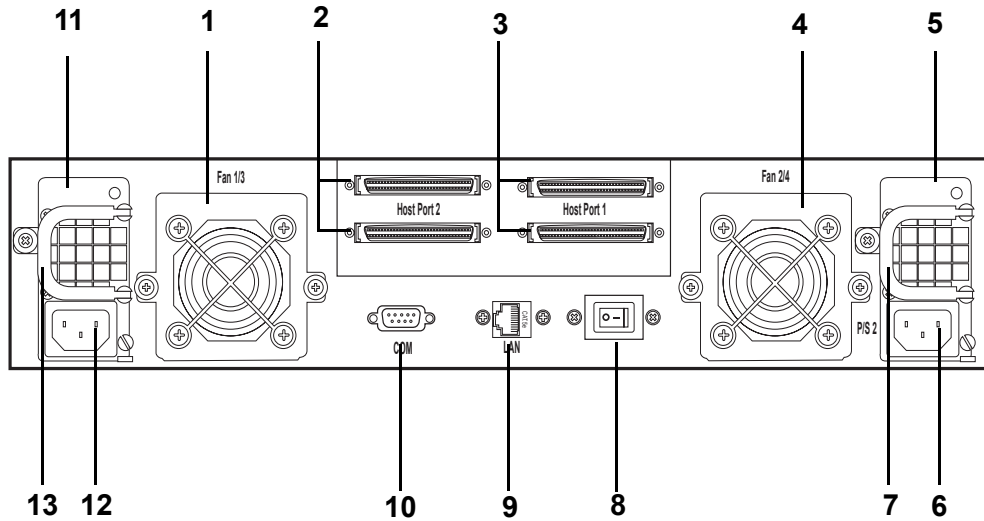

No.	Name	Description
1	Cooling fan 1/3	System cooling fan.(Fan1 is standard, Fan3 is optional)
2	Host Port 2 (Secondary SCSI channel)	Connects to the host server.
3	Host Port 1 (Primary SCSI channel)	Connects to the host server.
4	Cooling fan 2/4	System cooling fan.(Fan2 is standard, Fan4 is optional)
5	Power Supply 2	Removable redundant power supply 2.
6	Power Supply AC In	Connects to a 100-240 VAC power source.
7	Power Supply Handle	For power supply removal.
8	Power Switch	Switches the power on or off.
9	Ethernet Port	Used for browser-based configuration.
10	RS-232 Port	Connects to a VT100 terminal or equivalent.
11	Power Supply 1	Removable redundant power supply 1.
12	Power Supply AC In	Connects to a 100-240 VAC power source.
13	Power Supply Handle	For power supply removal.

Installing Disks

This section describes how to install disks in the disk array system.

- 1 Unlock the disk tray with an included disk tray key

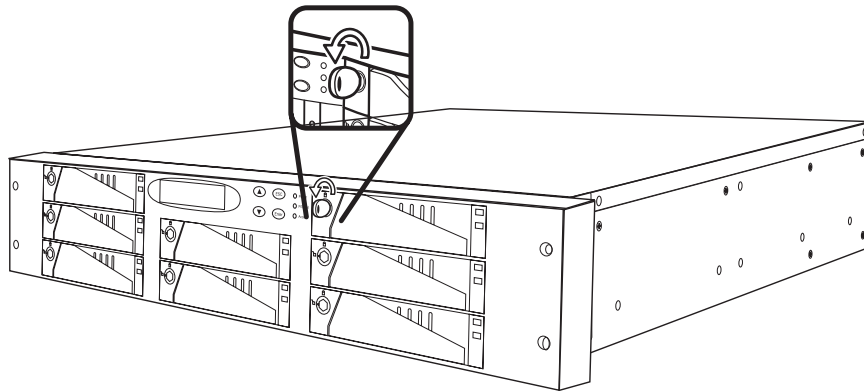

- 2 Gently pull the disk tray handle to the opened position.

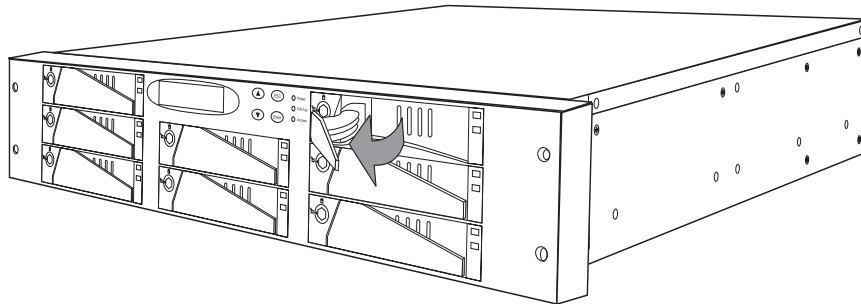

- 3 Remove the disk tray

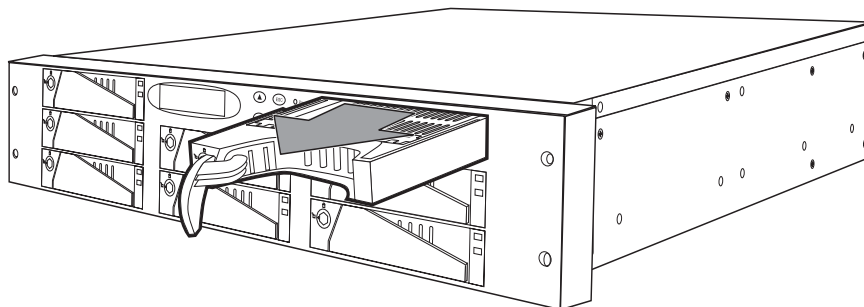

SA-4340S Serial ATA II Disk Array Systems

- 4 Insert the disk into the disk tray and fix into place with screws supplied with the disk.

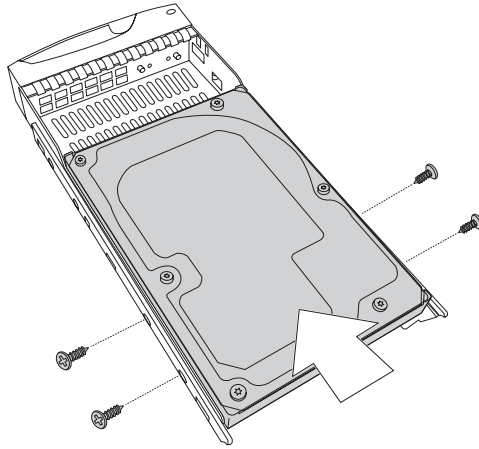

- 5 Slide the disk tray back into the empty slot.

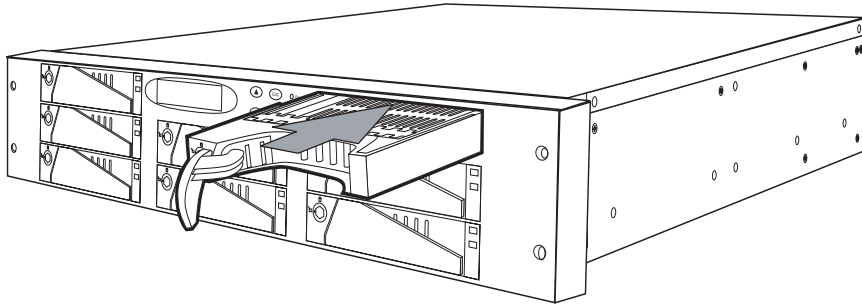

- 6 Slowly push the disk tray handle closed.

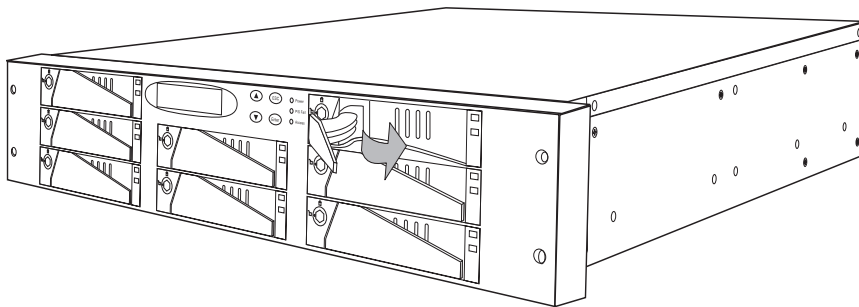

- 7 Lock the disk tray with the key.

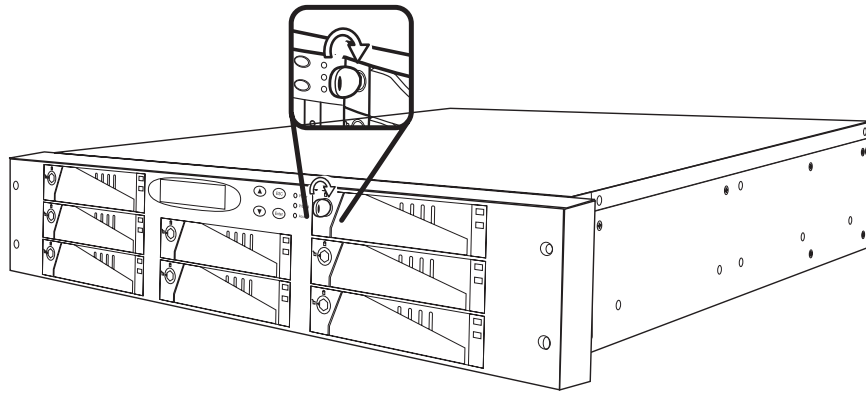

- 8 Repeat steps 1 to 8 until all of the required disks have been installed.

Making Connections

After the required number of disks have been installed, external connections to the disk array system must be made. This section describes how to make all of the necessary connections.

Connecting the Host Interface

The disk array system has either dual SCSI interfaces or dual fibre channel interfaces. Refer to the following sections to make host interface connections.

Small Computer Systems Interface

The SA-4340S has dual Ultra320 SCSI interfaces. Follow these instructions to make connections.

- 1 Connect the SCSI terminator (**A**) to the right top connector of the SA-4340S host port 1 (primary SCSI channel) at the rear of the disk array system.

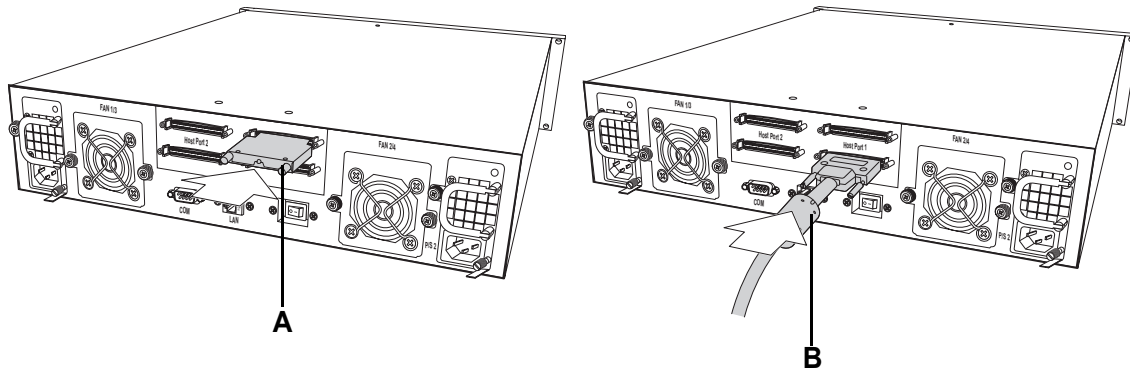

- 2 Connect the Ultra320 SCSI cable (**B**) to the right bottom connector of the SA-4340S host port 1 (primary SCSI channel) at the rear of the disk array system.

Connecting a network

Connect the network cable to the RJ-45 port at the rear of the unit.

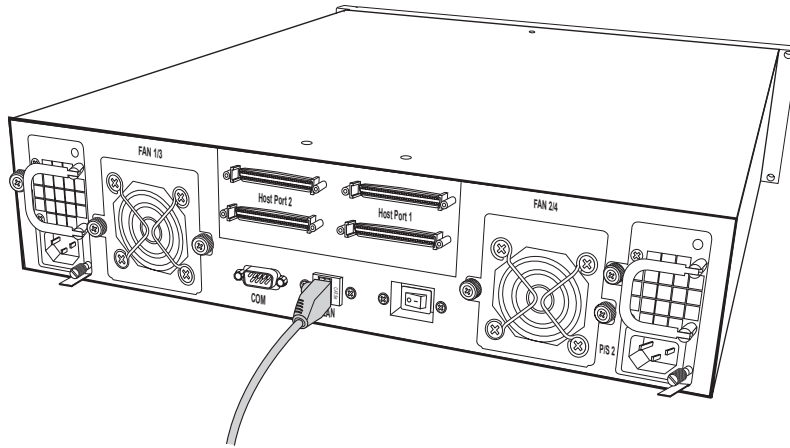

Connecting and Turning on the Power

- 1 Plug a power cable (**A**) to a power connector at the rear of the unit, then plug the second power supply cable into the second power connector (**B**).



Note

The system is equipped with auto switching power supplies that can run on 100 to 240 VAC.

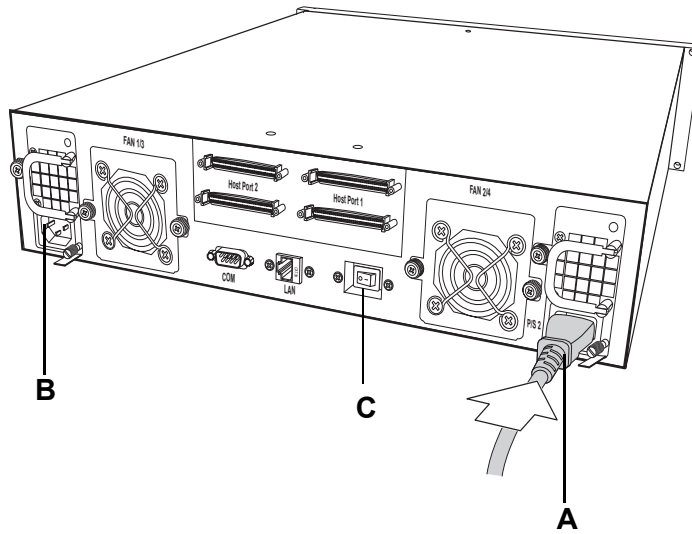

- 2 Switch (C) on the disk array system.

3 Maintenance

Replacing a Disk

A disk failure is indicated when the Power/Error LED at the front of the drive tray turns red and the audible alert sounds.



Note

Turn off the audible alert by pressing the Up ↑ and Down ↓ function buttons on the front panel twice simultaneously.

The LCD panel displays the failure with the symbol “R” or “W”. “R” indicates a disk failure or error, and “W” indicates that there are too many bad sectors on the disk.

Example:

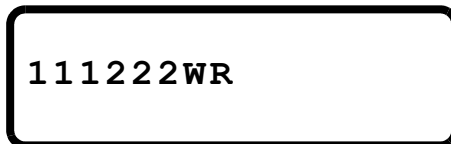

- Disks 1 to 3 are members of array group 1.
- Disks 4 to 6 are members of array group 2.
- Disk 7 has too many bad sectors.
- Disk 8 has an error or a fault.

Disks are hot swappable, which means that they can be inserted and removed while the disk array system is powered on and operating. Follow these instructions to replace a failed disk.

- 1 Unlock the front panel door, then pull it open.
- 2 Pull the tray handle away from the disk tray to release it; and pull the disk tray out.
- 3 Remove the screws from the failed disk, then remove the disk from the disk tray.
- 4 Align the rear of the new disk with the rear of the disk tray.
- 5 Insert the new disk into the disk tray.



Note

The new disk must have the same or a greater capacity than the faulty disk that was removed. If the disk capacity is smaller, the audible alert sounds and the auto-rebuild operation doesn't start. For best performance, it is recommended that the new disk be identical to the failed disk.

- 6 Attach the disk to the disk tray with the screws that came with the disk.
- 7 Slide the disk tray back into the empty slot, then close the disk tray handle.
- 8 Push the front panel door closed, and lock it.

Replacing a Power Supply

The disk array system is equipped with a Power Supply Fail Indicator LED at the front of the unit that turns red when one of the power supplies fails. The message “Power x failure” also appears on the LCD panel, where x refers to power supply 1, or 2, and an audible alert sounds.



Note

Turn off the audible alert by pressing the Up ↑ and Down ↓ function buttons on the front panel twice simultaneously.

Power supplies are hot swappable, which means that they can be inserted and removed while the disk array is powered on and operating. Follow these instructions to replace a failed power supply.

- 1 Identify the power supply that has failed.

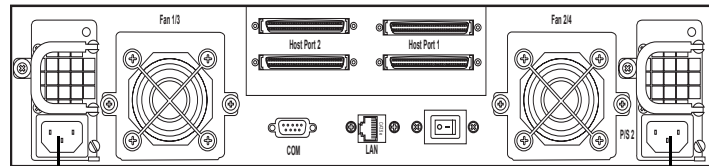

Power Supply 1

Power Supply 2

- 2 Remove the power cable from the power supply connector at the rear of the unit.



Note

The system is equipped with auto switching power supplies that can run on 100 to 240 VAC.

- 3 Loosen the power supply retaining screw.

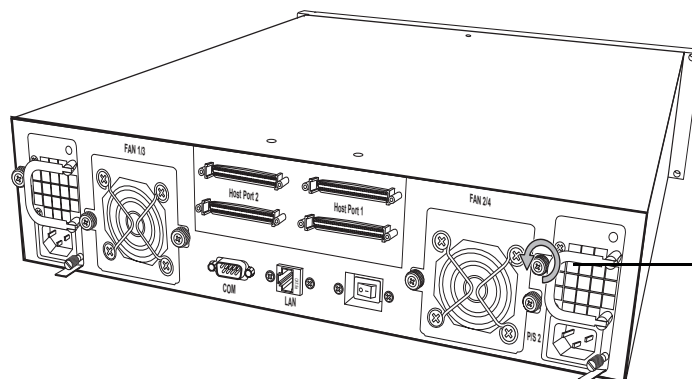

Power Supply retaining screw

- 4 Pull the power supply handle out.

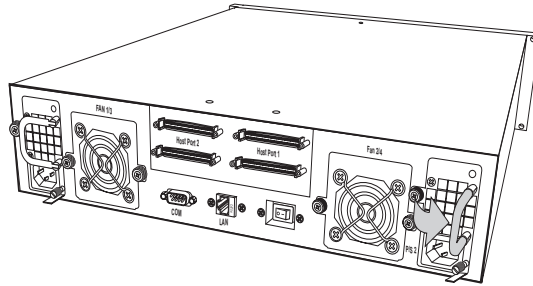

- 5 Remove the faulty power supply by pulling the power supply handle **A** and pressing the release catch **B** at the same time.

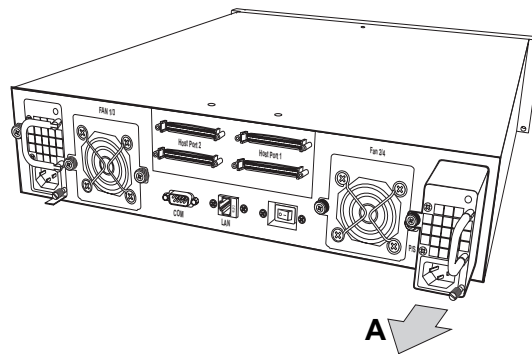

- 6 Insert a new power supply.

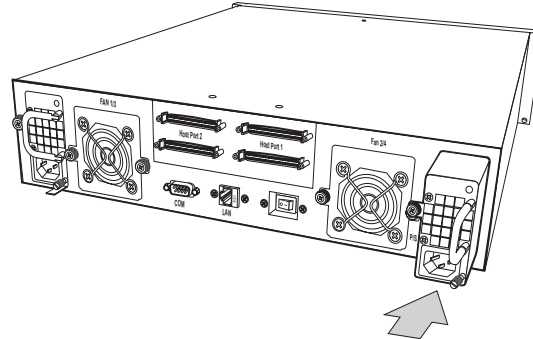

- 7 Push the power supply handle into place.

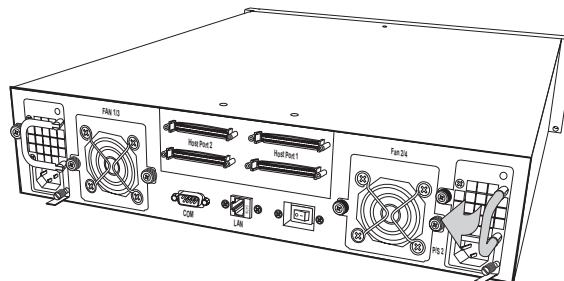

SA-4340S Serial ATA II Disk Array Systems

- 8 Tighten the power supply thumbscrew

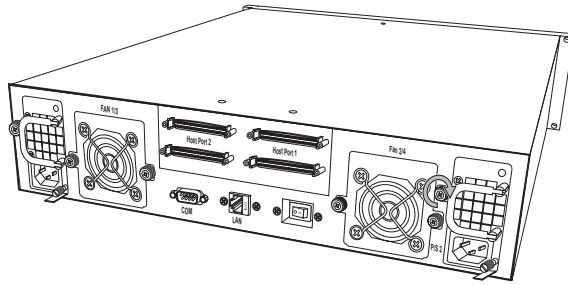

- 9 Reconnect the power cable.

Upgrading Memory

The disk array system takes a single DDR-333 200-pin DIMM with a maximum capacity of 1 GB. Follow these instructions to upgrade the memory.

- 1 Remove the screws from the disk array system top cover and lift the cover as illustrated.

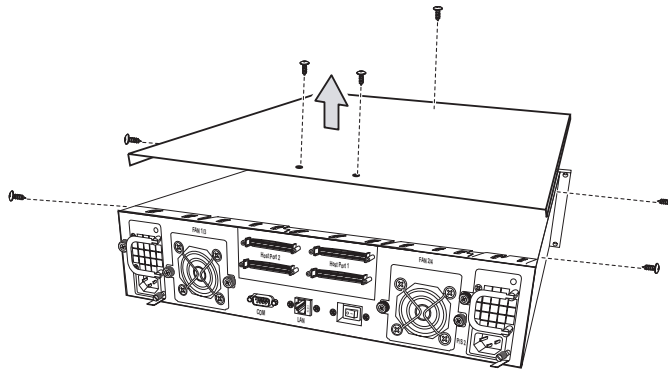

- 2 When open the cover, the controller can be seen clearly and the DIMM just on it. Pull the DIMM retaining clips away from the DIMM.

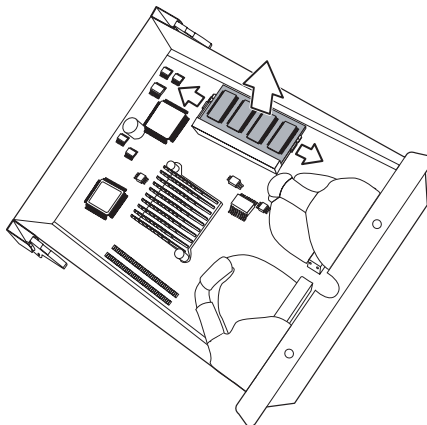

- 3 Then remove the DIMM. The DIMM springs out of the socket.

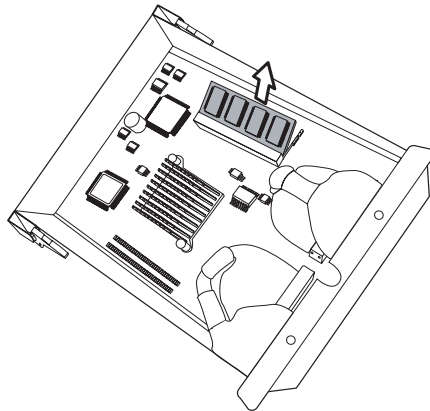

- 4 Gently push the new DIMM into the stock at 45 degrees.

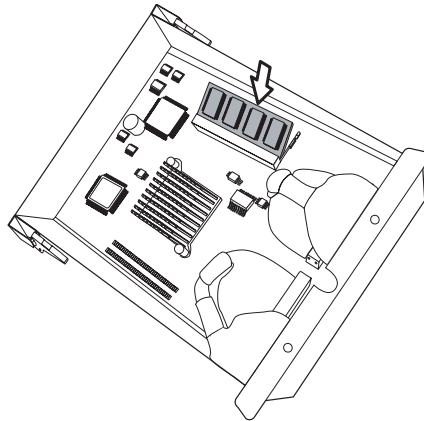

- 5 The push the corners of the DIMM down. The DIMM is secured by the DIMM socket retaining clips.

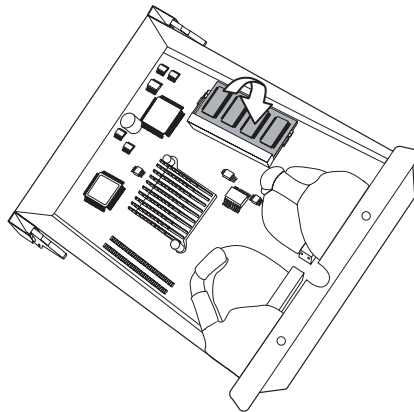

Note

The DIMM module will fit in only one direction. Do not force the DIMM into place.

SA-4340S Serial ATA II Disk Array Systems

- 6 Place the top cover on the disk array system and replace the screws to fix the top cover on the disk system chassis.

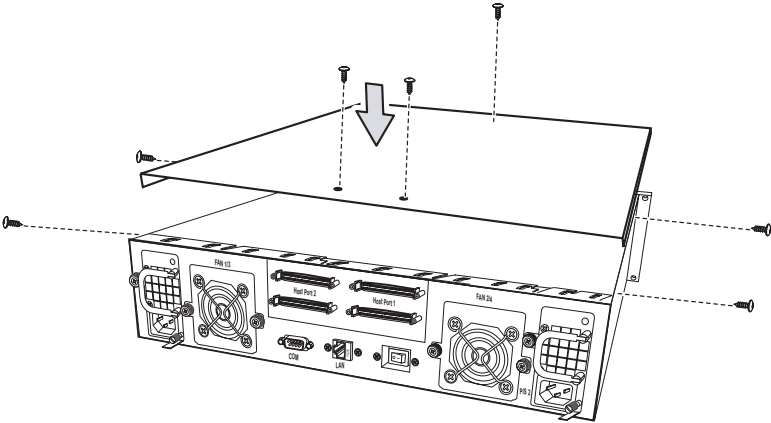

Appendix

Hardware Specifications

Item	Specification
Host Interface	SCSI Ultra320
Disk Interface	SATA II, 3.0 Gb/s
Dimensions	88 mm (H) x 480 mm (W) x 470 mm (D)
RAID Functions	<ul style="list-style-type: none">• Raid levels: JBOD, 0, 1, 0+1, 3, 5, 30, 50, 6, TP, NRAID• Hot spare support• Disk hot swapping with automatic online rebuilding• Multiple RAID (max. 8)
Disk Array Functions	<ul style="list-style-type: none">• O/S independent and transparent• Up to 1GB DDR SDRAM• LCD panel operation indicator• Audible alarm/disable alarm• LED indicator on disk failures
Connectors	<ul style="list-style-type: none">• 4 x Ultra320 SCSI ports(2 channels) (SA-4340S)• 1 x RS-232 Serial port (115200, 8, N, 1)• 1 x RJ-45 Ethernet port (10/100 Mbps)
Power Supply	<ul style="list-style-type: none">• Redundant, 300 Watt• 100 - 240 VAC, 47-63 Hz, 6~3A +/- 10%• Over voltage, current, power, and short circuit protection• LED indicates power status• Operating temperature: 5°C ~ 40°C• Operating humidity: 10 ~ 85% (non condensing)• Output: +5V, +3.3V, +12V
Warranty	3 year warranty
Safety	UL, CE and FCC Class B

SA-4340S Serial ATA II Disk Array Systems

Item	Specification	
Controller	CPU	Intel i80331 64-bit RISC microprocessor
	Disk Interface	SATA II (3.0 Gb/s)
	Disk Channels	8 channels (SA-4340S)
	Memory Type	DDR-333 200-pin DIMM
	Memory Sockets	1
	Memory Size	Up to 1 GB
	Button Interface	Up, Down, Enter, and ESC
	Backplane Interface (connector)	Compact-PCI
	Temperature Sensors	2
	Backplane	Disk Channel Support
Disk Number Supported		8 channels (SA-4340S)
Disk Connector Type		Serial ATA II
Temperature Sensors		5
Power Connector Type		2 x Slot-2
Fan Connector Type		4 x Slot-2