



est. 1878

USER- MANUAL TV7000MKII

Tamson Instruments bv

Van 't Hoffstraat 12
2665 JL Bleiswijk, The Netherlands
T. 31 (0) 10 522 43 73
F. 31 (0) 10 521 19 41
tv7000mkII-man.doc Rev. 2.1 UK 5-13

E-mail: sales@tamson.com
Website: www.tamson.com

VAT: NL 80 66 34 984 B01
Bank account no.: Rabobank 16 01 00 046
Chamber of commerce 27 16 95 41
IBAN Code: NL95 RABO 0160100046

Page 1/29



est. 1878

1	SAFETY AND WARNINGS	4
2	WARRANTY	4
3	PRECAUTIONS AND HAZARDS	5
4	INSTALLATION	5
4.1	IMPORTANT	5
4.2	UNPACKING	5
4.3	BATH LIQUID	6
4.4	BATH FLUID LEVEL	7
4.4.1	Minimum level	7
4.4.2	Maximum level	8
4.5	BATH FLUIDS	9
COOLING		13
4.6	CONNECTING	14
5	INTRODUCTION	15
5.1	GENERAL	15
5.2	CONSTRUCTION	15
5.3	STIRRER	15
5.4	TEMPERATURE CONTROL AND SETTING	15
5.5	SAFETY SYSTEMS	16
5.6	ADJUSTING THE MECHANICAL OVER-TEMPERATURE PROTECTION THERMOSTAT	16
5.7	FRONT PANEL	16
5.8	OVERVIEW MENU ITEMS	17
5.9	SAFETY THERMOSTAT	17
5.10	DISPLAY	18
6	OPERATING THE SYSTEM	19
6.1	QUICK START	19
7	MENU ITEMS	19
7.1.1	Menu item "Set point"	19
7.1.2	Menu item "Offset"	19
7.1.3	Menu item "Max Power"	20
7.1.4	Menu item "Boost heater"	20
7.1.5	Menu item "Time const"	20
7.1.6	Menu item "Stirrer"	20
7.1.7	Menu item "Low alarm"	20
7.1.8	Menu item "High alarm"	20
7.1.9	Menu item "PID parameter"	20
7.1.10	Menu item "Backlight"	20
7.1.11	Menu item "Temp units"	21
7.1.12	Menu item "Baudrate"	21
7.1.13	Menu item "Offset 0.005"	21
7.1.14	Menu item "Restart"	21
7.2	PID SETTINGS	22
7.3	MANUAL TUNING	23
7.4	PRECISION OF CONTROL	24
7.5	LONG TERM STABILITY	24
8	STANDARD DEV : 0,002°C RS232 COMMANDS	24
9	TROUBLE SHOOTING	25
9.1	APPLICATION ERRORS	25
9.2	BATH MALFUNCTION	25
9.3	PROBLEMS WITH SET POINT	25
9.4	FAULTY TEMPERATURE READING OR TEMPERATURE OFFSET	25
9.5	BATH TEMPERATURE DOES NOT BECOME STABLE	25

Tamson Instruments bv

Van 't Hoffstraat 12
2665 JL Bleiswijk, The Netherlands
T. 31 (0) 10 522 43 73
F. 31 (0) 10 521 19 41
tv7000mkII-man.doc Rev. 2.1 UK 5-13

E-mail: sales@tamson.com
Website: www.tamson.com

VAT: NL 80 66 34 984 B01
Bank account no.: Rabobank 16 01 00 046
Chamber of commerce 27 16 95 41
IBAN Code: NL95 RABO 0160100046



est. 1878

9.6 BATH DOESN'T REACH SP26

10 SPARE PARTS LIST27

11 DIMENSIONS 27

12 EC DECLARATION OF CONFORMITY THERMOSTATIC BATH TV-SERIES 28

13 DISCLAIMER 29

Tamson Instruments bv

Van 't Hoffstraat 12
2665 JL Bleiswijk, The Netherlands
T. 31 (0) 10 522 43 73
F. 31 (0) 10 521 19 41
tv7000mkII-man.doc Rev. 2.1 UK 5-13

E-mail: sales@tamson.com
Website: www.tamson.com

VAT: NL 80 66 34 984 B01
Bank account no.: Rabobank 16 01 00 046
Chamber of commerce 27 16 95 41
IBAN Code: NL95 RABO 0160100046

1 SAFETY AND WARNINGS

Make sure before installing or operating the equipment to read and understand all instructions and safety precautions listed in this manual. If there are any questions concerning the operation of the equipment or about the information given in this manual please contact your local dealer or our sales department first.

Performance of installation, operation, or maintenance other than those described in this manual may result in a hazardous situation and may void the manufacturer's warranty.

Never operate equipment that is not correctly installed. Unqualified personnel must not operate the equipment. Avoid damage to the equipment, or its accessories, caused by incorrect operation.

Important:

- When performing service, maintenance or moving the apparatus, always disconnect the apparatus at the main's socket,
- Proper skilled and trained personnel are only allowed to operate this equipment,
- Take notice of warning labels and never remove them,
- Refer service and repairs to qualified technician,
- If a problem persists, call your supplier or Tamson Instruments bv.

2 WARRANTY

Tamson Instruments bv. warrants that all their manufactured equipment is free from defects in material and workmanship, preventing the machine from normal operation. Tamson Instruments bv does not warranty that the equipment is fit for any other use than stated in this manual. The manufacturer can only be held responsible for the security, reliability and performance of the equipment, when operated in accordance with the operating instructions, extensions, adjustments, changes and/or if repair is performed by Tamson Instruments bv. or authorized persons only. This warranty is limited to one year from the date of invoicing. All equipment and materials are subject to standard production tolerances and variations.

3 PRECAUTIONS AND HAZARDS

Before attempting to operate the bath read all parts of this manual carefully to insure smooth operation and avoid damage to the equipment or its accessories.

If a malfunction occurs, consult section "TROUBLE SHOOTING", page 25 at the end of this manual. If a problem persists, call your supplier or Tamson Instruments bv. Never operate the equipment if not correctly installed. The equipment must be operated only by qualified personnel. Avoid damage to the equipment or its accessories through incorrect operation.

4 INSTALLATION

4.1 Important

Tamson Instruments bv is not responsible for any consequential damage or harm caused by using this bath. Repairs on the electrical system of the bath may only be carried out by well trained and authorized persons.

4.2 Unpacking

Before leaving the factory Tamson baths are adequately packed to prevent damage during normal transportation. Check the packing for external damage and make a note on the shipping documents if any damage is found. Always retain the cartons and packing material until the bath has been tested and found in good condition. (Transport companies generally will not honor a claim for damage if the respective packing material is not available for examination).

The shipment contains at least the bath as mentioned in the delivery checklist. Further the consignment might contain one or more viscometers, individually packed in small boxes with the calibration certificate included in the box, as well as ASTM thermometers, thermometer holders etc. Please see the packing list for details concerning total contents of consignment.

Before filling the bath remove any remaining packing material from its interior. The interior of the bath can be accessed by taking off the lid on the top of the bath.

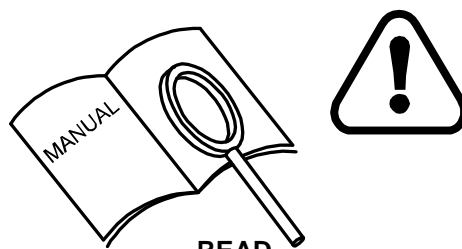

READ CAREFULLY

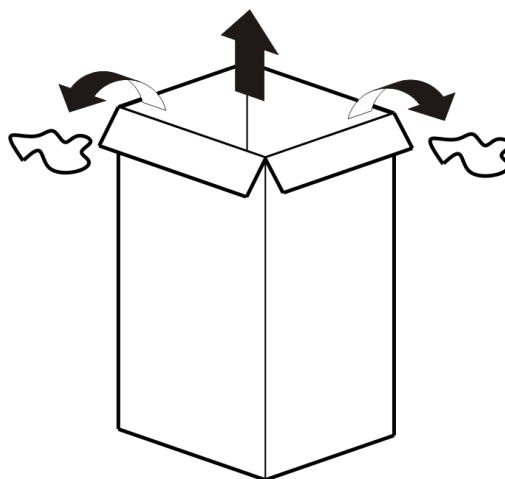
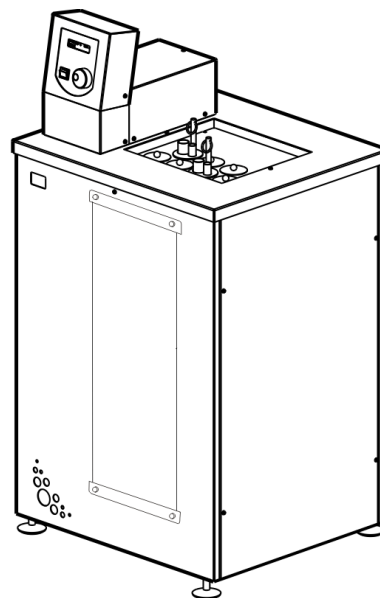

REMOVE ALL PACKAGE MATERIAL

4.3 Bath liquid

The bath must be filled with a liquid suitable for the minimum operating temperature.

It is very important to select a liquid with a viscosity preferably less (e.g. 10 cSt) at the operating temperature and a flash point which is well above the operating temperature.

The use of other liquids is allowed as long as the viscosity of the fluid is low enough at the operating temperature. Following products can not be used as bath fluid:

- Distilled water,
- Aggressive fluids when in contact with stainless steel 304, 316, glass or PTFE and silicon sealing.

The fluid flashpoint must be well above the maximum operating temperature.

Drain bath fluid

The TV7000 can be emptied via the drain tap located at the left side of the apparatus. For safety reasons the tap can only be opened when using a screwdriver. The thread inside the tap is 3/8".

Take necessary precautions against fire hazard when removing flammable bath fluid.

**When removing bath fluid do not inhale toxic vapor
Always use appropriate ventilation.**

Handle old bath fluid as toxic waste.

Cool down bath fluid to ambient before removing.

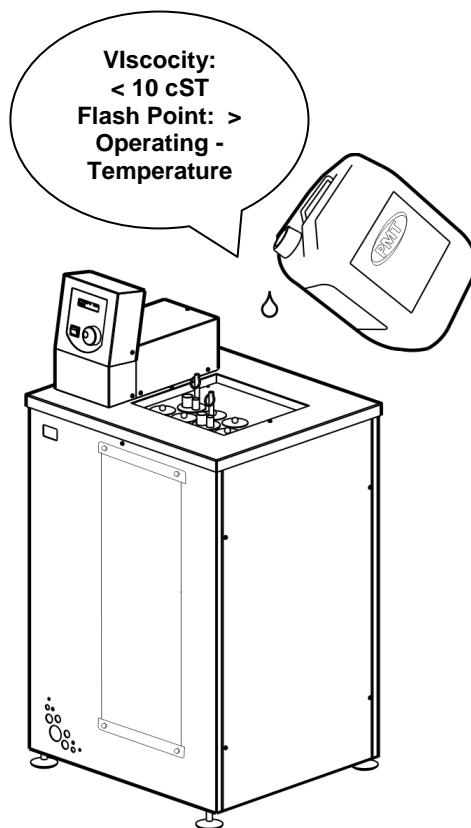

**USE SCREWDRIVER
TO OPEN TAP**
3/8" BSP inside thread

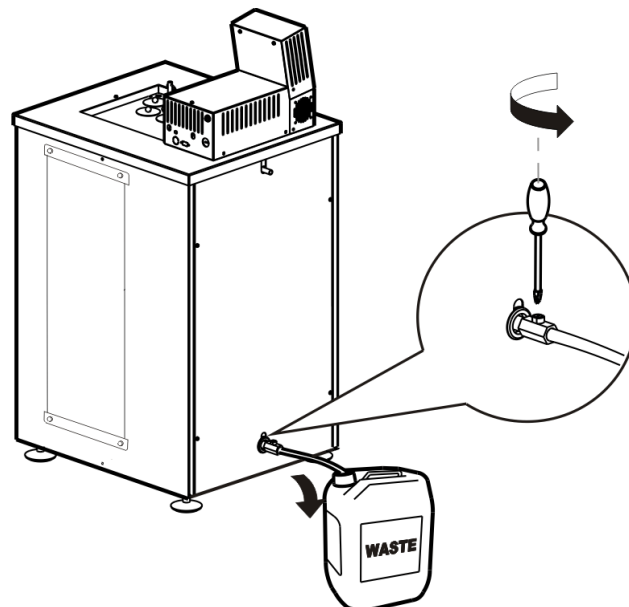

4.4 Bath fluid level

4.4.1 Minimum level

The heating element must be fully covered by the bath fluid.

The practical minimum level is indicated below

The level indicator(optional) will start to blink (blue light) when the fluid level is too low.

When the bath has been installed it must be filled with an appropriate liquid. When working with water the bath should be filled to 1 cm below the lid. For oil the bath should be filled to not more than 5 cm below the lid. Depending on the operating temperature the liquid level in the bath should be observed and excessive fluid should be removed.

The liquid level should be maintained between 1 and 3 cm below the lid during normal operation.

The heating element will be damaged when not fully submerged in the bath fluid. A lower level than 5 cm below the lid may damage the heaters. A high bath level can cause overflow and will might also damage the bath insulation.

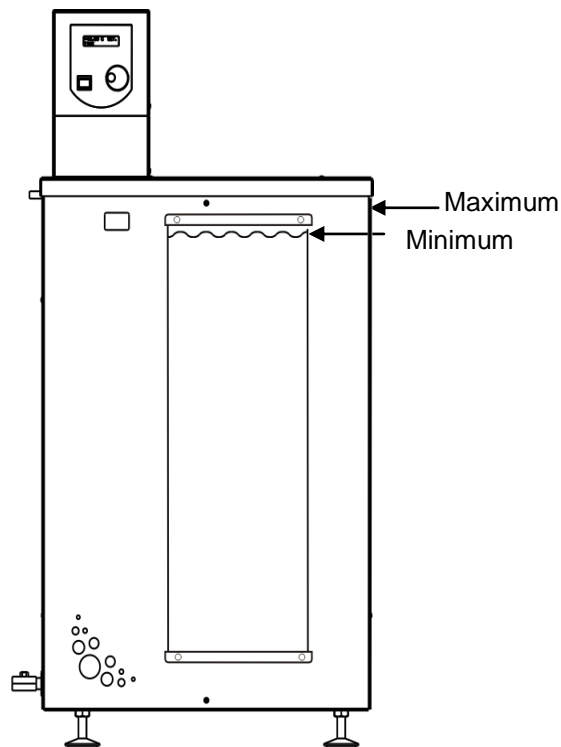

4.4.2 Maximum level

If the fluid level is too high, it will leave the bath via the overflow outlet (10mm outside diameter pipe). Prevent fluid from the overflow outlet entering the backside of the TV7000. For this reason the overflow outlet must be connected to a waste container.

When the bath is working at high temperatures, tubing and waste container must be chemical resistant and able to withstand high temperatures (>150°C / 302°F).

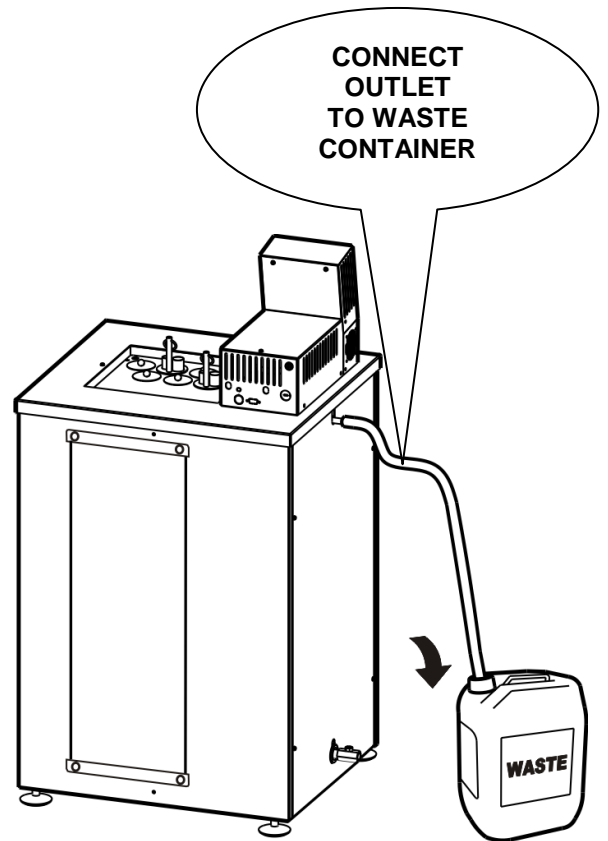

**TUBING AND CONTAINER:
CHEMICAL RESISTANT
WITHSTAND HIGH
TEMPERATURE**

PREVENT OVERFLOW

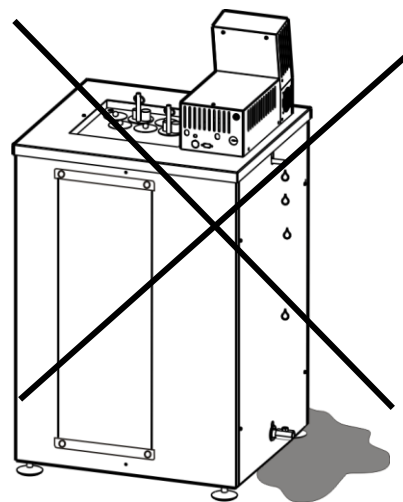

4.5 Bath fluids

We recommend the use of oil with viscosity < 10cSt.

Recommended bath fluids		
Range	Ordering code	Description
Ambient to 80°C/176°F	N.A.	Clean tap water NOT DISTILLED
80..150°C / 176..302°F	00T0220 (20 litres)	Tamson mineral oil 150. Transparent, 20cSt. @ 80°C/176°F; 3cSt. @ 150°C/302°F; F.P. 200°C/392°F.
20..150°C / 68..302°F	08T0001 (gross 20 Kg = 20 ltrs)	Silicon oil 200-10, transparent. 10 cSt. @ 25°C/77°F; 10 cSt. @ 150°C/301°F. F.P. 211°C/411°F. Lifetime >2 years.

The oil used has a limited lifetime.

The type, brand and operating temperature mainly determines lifetime. Spilling of sample may also reduce lifetime, in some cases can start chemical reactions. Silicon oil has the tendency to form gel, for this reason silicon oil has to be replaced as soon as visible changes are noticed like string forming. Within a few hours silicon oil can transform itself into solid gel, which is very difficult to remove. When not totally cleaned, very small pieces of left over gel will catalyze new oil to form gel!

Do not use distilled water. This will cause corrosion and wear of stirrer bearings.

Only use water as a bath fluid below 80°C/176°F. Working for a longer period with water at temperatures above 80°C will damage the stirrer bearings.

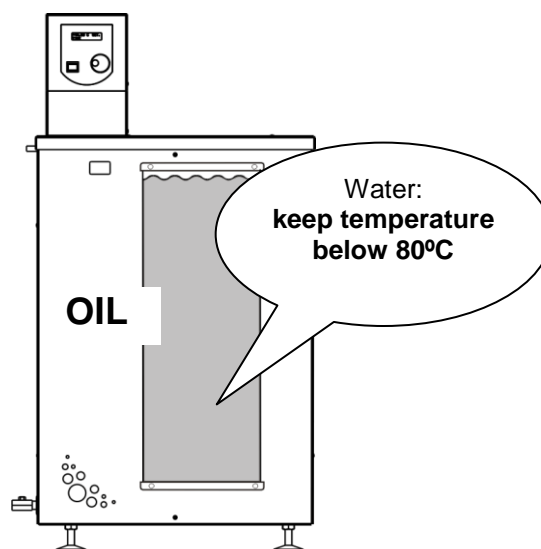

Using the bath for long periods at low temperatures will cause condensation on the glass window resulting in complete invisibility of material placed inside the bath.

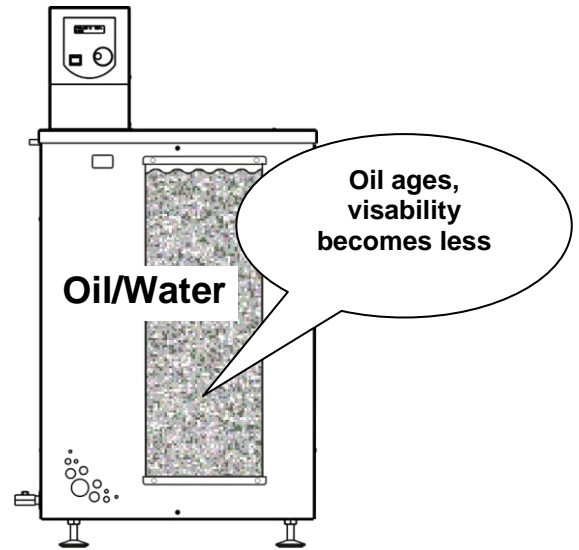

Tamson Instruments bv

When operating at high temperatures the lid (of the bath), top plate and the window section of the bath become very hot. Always use heat protective gloves. Care must be taken when placing or removing material from the bath.

WEAR PROTECTIVE GLOVES, CLOTHING AND EYE PROTECTION.

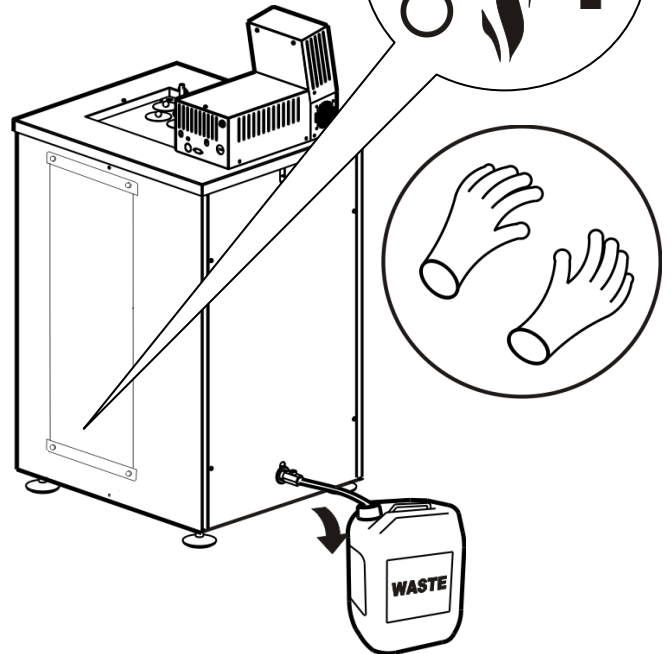

Pay attention when removing hot fluid:

Use heat protective clothing and wear gloves and safety glasses.

WEAR HEAT PROTECTIVE GLOVES

When changing the bath fluid from water to oil for operating at temperatures above 80°C, completely remove all the water from the bath. Small drops of water may result in hazardous situations while reheating the bath with oil.

Water and oil must at all times be kept separate within the bath. Never mix oil and water in or around the bath.

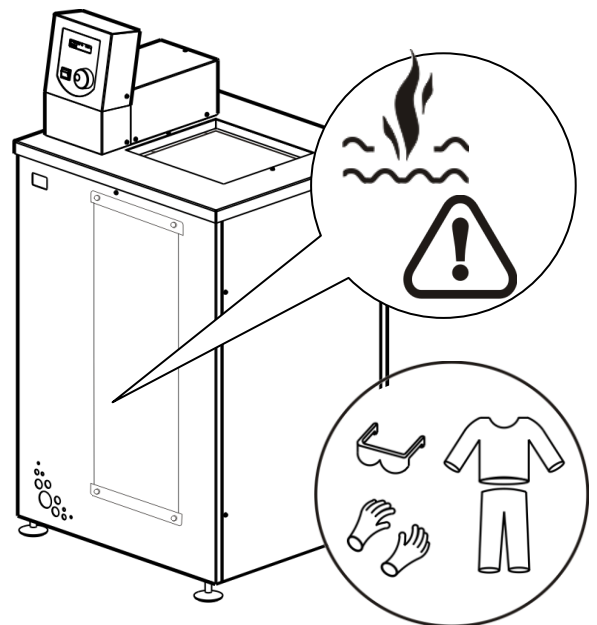

Do not spill water in hot oil.

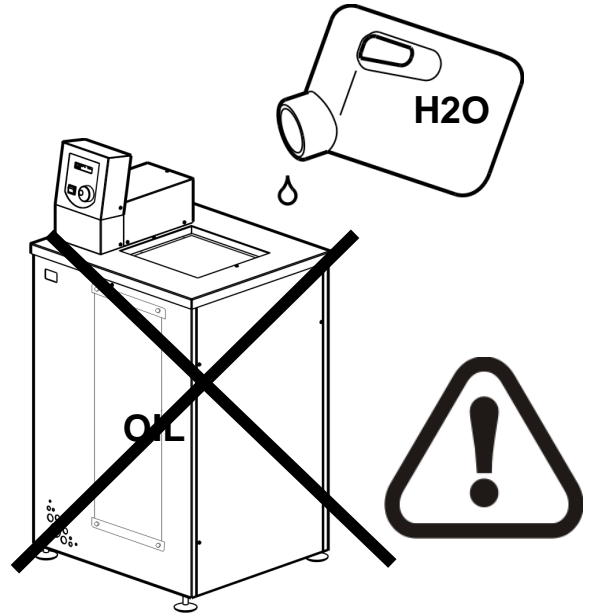

Never empty hot oil into a plastic container.

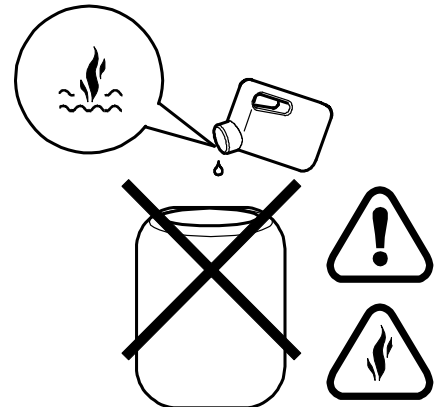

Heated bath fluid can cause toxic fumes. Take precautions and read material safety sheet if applicable.

Remove fumes from hot oil or bath medium. Use fume cabinet or proper air ventilation

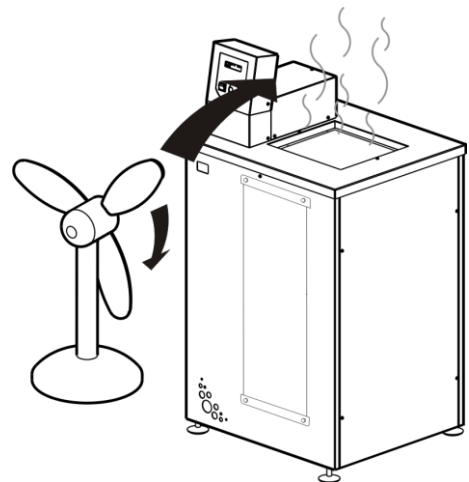

Cooling

The bath is provided with an integral cooling coil. Because of the friction-heat generated by the stirrer mechanism the bath will heat-up slowly. The lowest operating temperature at which the bath can be controlled depends on the fluid used and the ambient temperature. When operating at temperatures around or below ambient it is necessary to pass a small amount of tap water through the cooling coil. Generally the temperature of the cooling coil water should be 5 degrees (or more) below the desired operating temperature of the bath. To operate around ambient temperature a flow of 1 to 2l/min. is sufficient.

Instead of using tap water a Tamson cooling circulator can be connected to the TV7000 to provide cooling. The TLC15-3 provides sufficient cooling to operate at ambient temperatures.

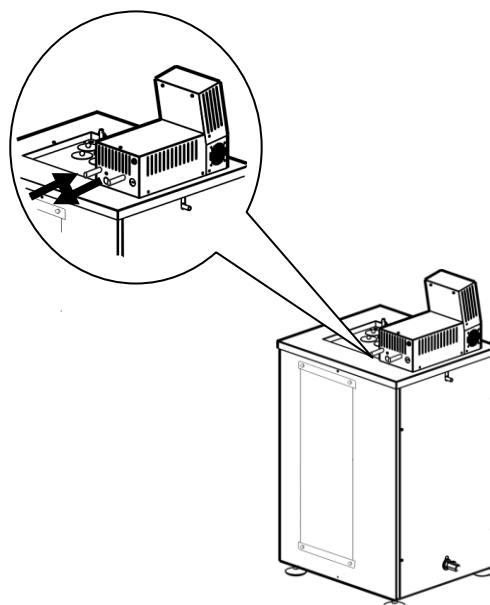

**TLC15-3
COOLING CIRCULATOR**

4.6 Connecting

Before plugging TV7000 into the mains socket, make sure the voltage of the bath corresponds to the local voltage.

Use a mains supply that is well earthed, clean of interference and suitable for the acquired electrical load of the bath.

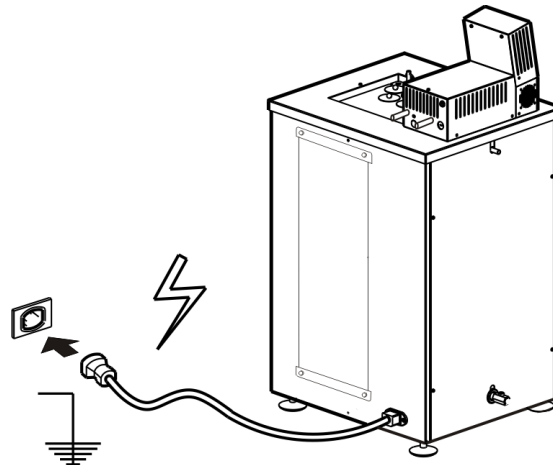

**CHECK VOLTAGE
USE WELL EARTHED MAINS**

5 INTRODUCTION

The TAMSON model TV7000 baths is designed to perform as very stable visibility bath. The intended use is kinematic viscosity measurement and sensor calibration.

5.1 General

The heat input is controlled by a microprocessor system. A special optimized electronic temperature measurement circuit ensures reproducibility of operation conditions. The baths have an integrated cooling coil as standard, for rapidly reducing bath temperature alternatively for working at or slightly below ambient temperature.

5.2 Construction

The TAMSON baths are constructed entirely from corrosion-resistant materials – stainless steel and PTFE – entirely. The central microprocessor within the control module manages and controls the functions for temperature measuring regulation, program storage, safety control and error coding.

5.3 Stirrer

A circulation stirrer is built-in for uniform temperature distribution within the bath.

5.4 Temperature control and setting

The bath temperature is regulated using a Pt-100 temperature probe Class A connected to a microprocessor module. The advanced electronic control system continually computes the energy input required for optimal temperature accuracy and stability. The controller will activate the heaters partially or in full, taking into account the difference between actual bath temperature and set point taking into account the type of bath fluid used and working conditions. This process does not interfere electrically with other equipment since all heating elements are switched in zero-cross mode. Through the application of an especially developed inlet circuit for the temperature probe, the sensitivity to external interference has been reduced to a minimum. The required temperature is set by means of membrane switches on the front panel. An absolute temperature offset is provided with a resolution of 0.01°C. This fine-tuning can be carried out at any time during operation of the bath.

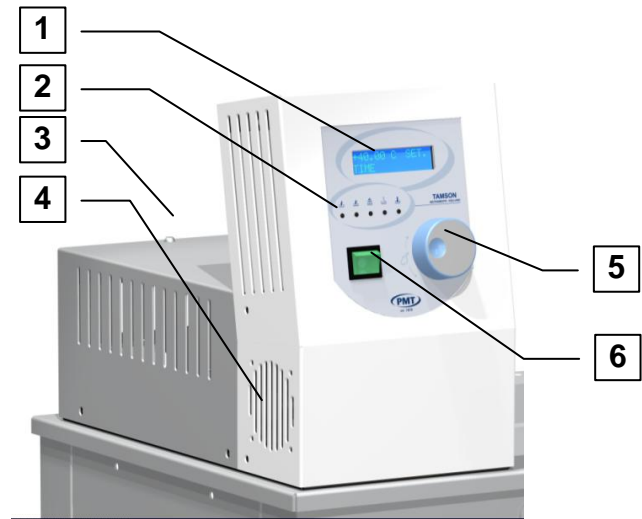

- 1: Display
- 2: Indicator lights
- 3: Overtemperature cut-out
- 4: Fan
- 5: Encoder switch
- 6: Mains switch

5.5 Safety systems

In case of electronic failure the possibility exists that the heater element is continuously switched on. This will cause extreme temperature raise. To prevent high temperatures the bath is fitted with a mechanical over-temperature protection thermostat. This thermostat will switch-off the bath at a preset temperature in the range from 50 to 270°C.

We advise to adjust the mechanical over temperature to approximately + 25°C above the bath set point.

This safety construction prevents for example oil to be heated above flaming-point which will cause fire or prevent evaporation of bath fluid due to high temperatures.

The thermostat will automatically reset when the bath temperature drops approximately 10°C below the pre-set temperature. To continue normal operation the bath has to be switched off and on again.

5.6 Adjusting the mechanical over-temperature protection thermostat

The over temperature thermostat is located on the back of the top compartment of the TV7000. Turn the thermostat clockwise (2, drawing 1) to its maximum. Be aware that the safety thermostat is now only functioning at 270 °C. Heat the bath to the appropriate set point. Gently turn the thermostat anti-clockwise, until the over-temperature protection is activated, and system switches off, Turn the thermostat approximately 30°...40° higher (turn clockwise). Switch the bath off and on again. The bath is ready to operate safely.

5.7 Front Panel

- 1 LC Display
- 2 Over temperature indicator (Red)
- 3 Level indicator, optional (Blue)
- 4 Error (Yellow)
- 5 Heater indicators (Green)
- 6 Mains switch
- 7 Safety thermostat
- 8 Turn-push button

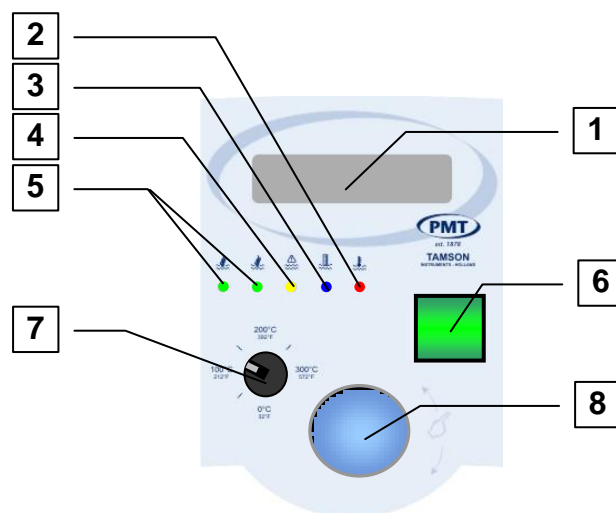

Use well grounded mains. Before plugging the TV7000 into the mains socket, make sure the voltage of the bath corresponds to the local voltage.

The front panel layout shows the turn-push button:

Next / increase: Turn right



Previous / decrease: Turn left



Select: Press

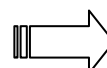

5.8 Overview menu items

- Set point
- Offset (press: $<-5.00 .. +5.00^{\circ}\text{C}$ resolution 0.01°C)
- Max Power (press: low 25, med, hi, max)
- Boost heater (press on / off)
- Time const (press: fast, medium slow, precise)
- Stirrer
- Low alarm
- High alarm
- PID parameter :
 - PID set 1,
 - PID set 2,
 - PID set 3,
 - PID set 4.Each PID set offers settings for
 - Proportional band value
($P_b=1/P$ where P is proportional value)
 - Integral value
 - Differential value
- Backlight
- Temp units
- Baudrate
- SP Offset
- Restart

5.9 Safety thermostat

When the bath temperature becomes higher than the set point temperature of the safety thermostat (Indicated as 7, see page 16), the heating electronics and controller are switched-off. The red LED on the display will light. When the temperature of the bath has been lowered with approximately 20°K , the thermostat re-sets itself automatically, however to continue normal operation the bath has to be switched off and on again.

5.10 Display

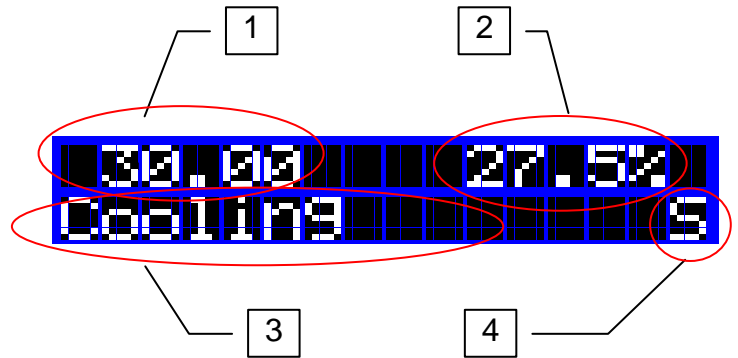

- 1 Temperature readout
- 2 Applied percentage of power
- 3 Operating mode
- 4 Indicator, alarm high, alarm low, control stable

Ad 1: When the controller starts or is restarted, the displayed value increases to a stable readout appears after a few seconds.

Ad 2: The controller calculates every second the amount of power which should be applied for stable control. The value is displayed with a resolution of 0.1% and ranges from 0% to 99.9%.

- Ad 3: Boost Bath is heating to set point using boost heater
- Heating Bath is heating to set point, boost heater is off
- Cooling Bath is cooling down to set point
- Tuning Ratio Bath is tuning for power needed at set point, first step
- Tuning SA Bath is tuning, second step
- PID SP=25.00 Bath is controlling, set point is 25.00°C (example)

Ad 4:

- Bath control is stable
- Alarm high, press button to reset
- Alarm low, press button to reset



6 OPERATING THE SYSTEM

When the bath is ready for use it can be switched on by pressing the mains switch.

The electronics are suited for both 50 and 60 Hz. Check whether the voltage of the system conforms to the mains voltage

6.1 QUICK START

To start operating the bath in a quick way do the following:

Fill the bath with fluid as indicated in "Bath fluid level", page 6,

Place the power plug, connect to mains socket,

Switch the bath on using the mains switch,

Select appropriate set point,

PID settings

All measuring results have been acquired using following PID settings:

Pb := 25

I := 16

D := 0

Under different settings its possible to achieve even better values by trimming the PID settings.

Place the bath spirit level. The 4 supporting feet can be turned in and outwards for exact adjustment.

7 Menu items

Use the turn-push button to select a menu item and select the item by pressing the button. After pressing a sign appears next to the value indicating the value can now be changed. Pressing the button again activates the value immediately. When the value is altered but the button is not pressed the value will be accepted and stored after 5 seconds automatically. The menu returns back to normal operating mode.

7.1.1 Menu item "Set point"

Select the set point temperature. Resolution is 0.01°C +/- the system accuracy.

7.1.2 Menu item "Offset"

The temperature displayed can be increased or decreased with an offset ranging from +5.00 down to -5.00 °C in steps of 0.01°C. This way the temperature reading on the display can be synchronised with an independent separate thermometer.

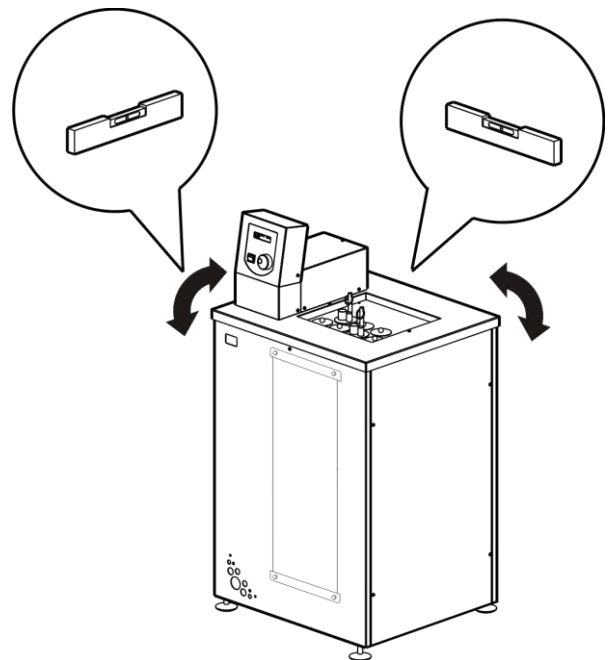

SPIRIT LEVEL

7.1.3 Menu item "Max Power"

(press: low 25, med, hi, max)

Limits the applied power by a maximum value:

Low	Maximum of 25% applied
Medium	Maximum of 50% applied
High	Maximum of 75% applied
Maximum	100% power is applied

7.1.4 Menu item "Boost heater"

A secondary heater is used to quickly heat up the bath.

This menu item enables or disables the heater.

Standard value: On

7.1.5 Menu item "Time const"

Used to select time to tune. The option precise has to be used to reach maximum temperature accuracy. Options are:

- Fast	60 seconds
- Medium	120 seconds
- Slow	180 seconds
- Precise	240 seconds

Standard value: Precise

7.1.6 Menu item "Stirrer"

Optional: Stirrer 0 .. 100% (step 6%). Inactive

7.1.7 Menu item "Low alarm"

Optional: min SP to max SP. resolution 0.1°C. No hardware connected, display function only.

7.1.8 Menu item "High alarm"

Optional: min SP to max SP. resolution 0.1°C. No hardware connected, display function only.

7.1.9 Menu item "PID parameter"

PID set 1	-	First set of parameters
PID set 2	-	Second set of parameters
PID set 3	-	Third set of parameters
PID set 4	-	Activated when communication via RS232

Each set offers individual PID settings for:

Proportional band value
Integrating value
Differentiating value

Default settings

Pb*	:=	25
I	:=	16
D	:=	0

*Pb= proportional band. Proportional value P is found to be 100/Pb.

7.1.10 Menu item "Backlight"

On



est. 1878

Off

Standard value: On

7.1.11 Menu item "Temp units"

°C

°F

Standard value: °C

7.1.12 Menu item "Baudrate"

300

600

1200

2400

4800

9600

19200

38400

Standard value: 9600

7.1.13 Menu item "Offset 0.005"

This menu item (optional) offers an additional offset of 0.005°C. The value of 0.005°C is added to the selected SP value. The SP can be selected with 0.01°C accuracy.

7.1.14 Menu item "Restart"

Restarts system and activates tuning

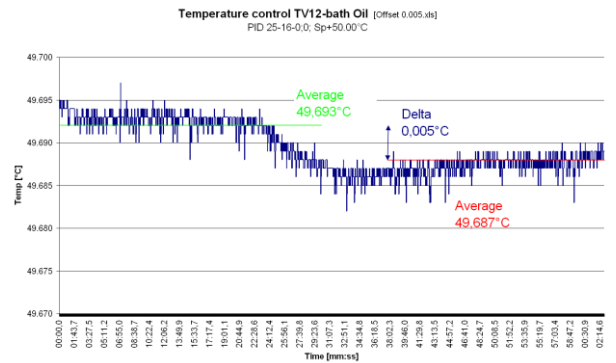

Tamson Instruments bv

Van 't Hoffstraat 12
2665 JL Bleiswijk, The Netherlands
T. 31 (0) 10 522 43 73
F. 31 (0) 10 521 19 41
tv7000mkII-man.doc Rev. 2.1 UK 5-13

E-mail: sales@tamson.com
Website: www.tamson.com

VAT: NL 80 66 34 984 B01
Bank account no.: Rabobank 16 01 00 046
Chamber of commerce 27 16 95 41
IBAN Code: NL95 RABO 0160100046

7.2 PID settings

Following shows influence on stability with different PID settings

Temperature : 75°C
 Proportional band (Pb) : 25
 Integrator : 16
 Differentiator : 0
 Min/max : ± 0,015

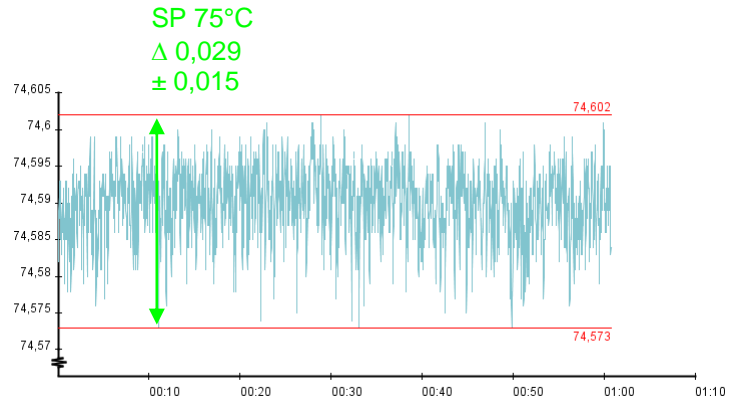

Temperature : 75°C
 Proportional band (Pb) : 50
 Integrator : 25
 Differentiator : 0
 Min/max : ± 0,018°C

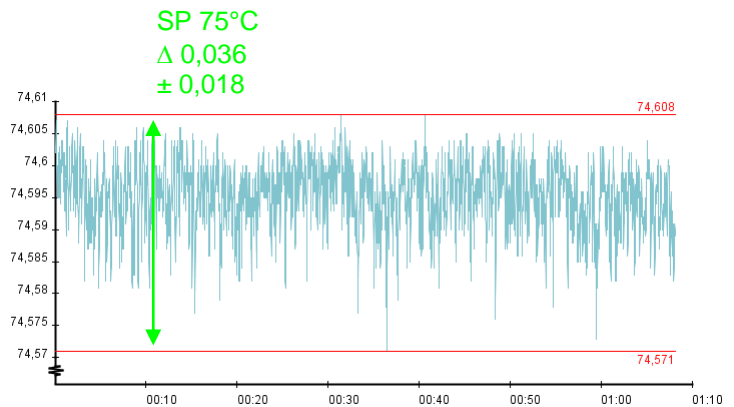

Temperature : 75°C
 Proportional band (Pb) : 100
 Integrator : 25
 Differentiator : 0
 Min/max : ± 0,045°C

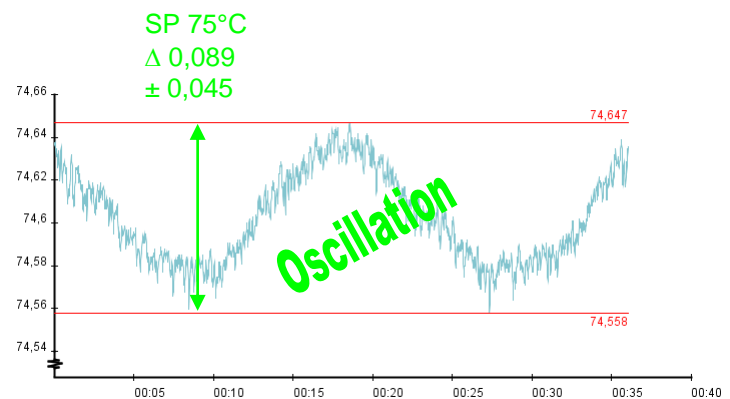

7.3 Manual tuning

The parameters for the PID control can be changed manually.

The control of the PID parameters allow setting of the I and D values to zero. The bath will then function as a proportional system. The "P" parameter can than be varied to an optimal value by trial and error. A higher P will stabilize the system when I and D are off. The PID parameters can also be determined with the use of the Ziegler Nichols method described below.

The PID parameters can also be determined with the use of the Ziegler Nichols method described below. With the process at its normal process value.

Ignore the fact that the temperature may not settle precisely at the set point. If the temperature is stable, reduce the proportional band P_b so that the temperature just starts to oscillate. If the temperature is already oscillating, increase the proportional band until it begins oscillating. Allow enough time between each adjustment for the loop to stabilize. Make a note of the proportional band value "B" and the period of oscillation "T" Set the P_b , T_i and T_d parameter values according to the calculations given in the table below:

Type of control	Proportional band	Integral time "ti"	Derivative Time "td"
Proportional only	2xB	Off	Off
P + I control	2,2xB	0,8xT	Off
P + I + D control	1,7xB	0,5xT	0,12xT

7.4 Precision of control

Temperature : 40°C
 Proportional band (Pb) : 25
 Integrator : 16
 Differentiator : 0
 Min/max : ± 0,008°C

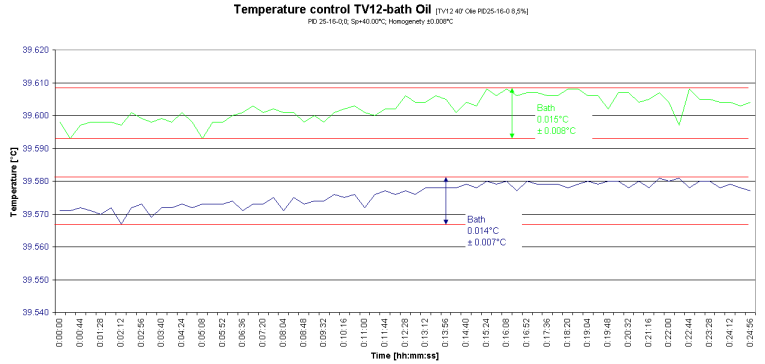

Temperature : 50°C
 Proportional band (Pb) : 25
 Integrator : 16
 Differentiator : 0
 Min/max : ± 0,008°C

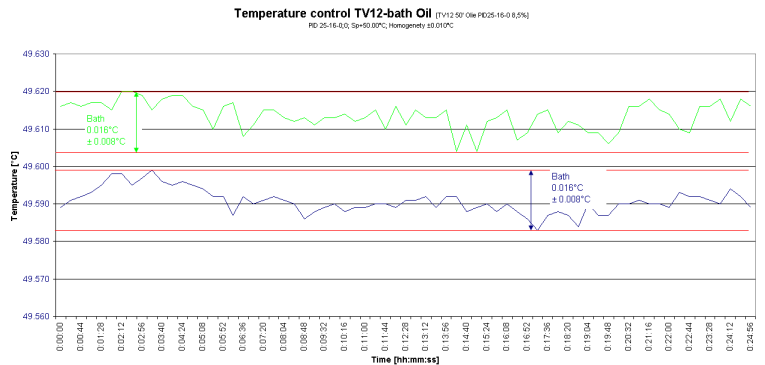

Temperature : 60°C
 Proportional band (Pb) : 25
 Integrator : 16
 Differentiator : 0
 Min/max : ± 0,011°C

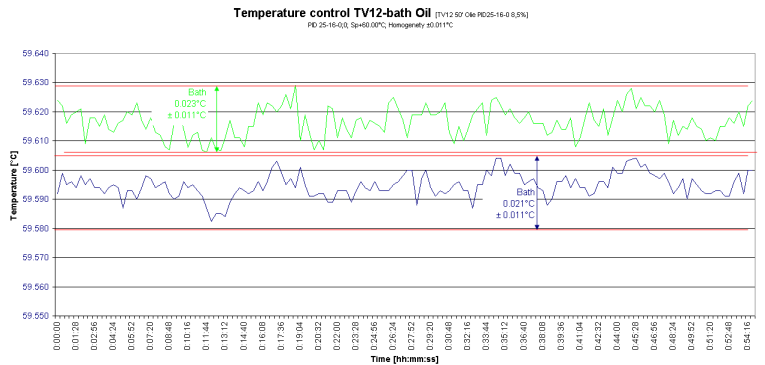

7.5 Long term stability

Temperature : 40°C
 Time period : 4 hrs
 Proportional band (Pb) : 25
 Integrator : 16
 Differentiator : 0
 Min/max : ± 0,008°C
 Standard dev : 0,002°C

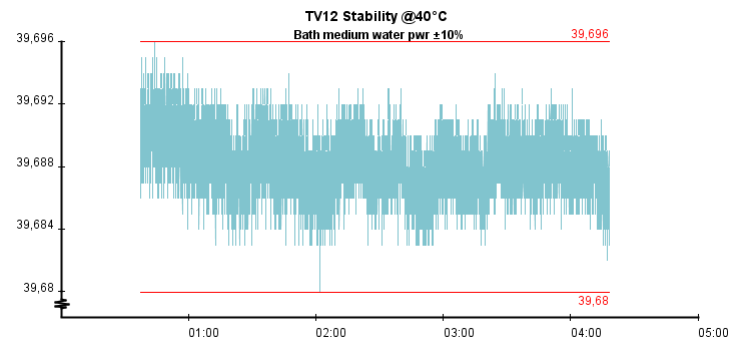

8 TROUBLE SHOOTING

8.1 Application errors

All Tamson products are well designed and thoroughly tested before shipping. This will not fully prevent small problems in the field. Following will help you to locate commonly known problems and how to fix them. In case of doubt please check your local dealer or Tamson instruments bv.

8.2 Bath malfunction

- The pump motor is not running and electronics are dead.

Check mains and main fuse.

Check over-temperature protection see "Temperature control and setting" page 16.

- Motor is not turning

The motor fuse is activated. *Restart the motor by pressing the motor fuse. This fuse is located at the backside of the top casing. Also check viscosity of the bath fluid. High viscosity will activate the motor fuse.*

Electrical defect.

Motor capacitor defective, replace capacitor or contact local dealer or Tamson instruments bv

8.3 Problems with set point

- Heater LED is not burning, motor is turning and temperature rises above set point.

Set point too near to room temperature. *Cooling of the bath is needed.*

- Temperature doesn't reach set point, motor turns fast.

Bath fluid evaporates too quickly. Use other fluid.

Heater malfunctions. *Measure mains electrical current output. Low power consumption indicates a problem with the heating element.*

Cooling capacity is too high. *Reduce cooling.*

- Temperature not stable

See explanation "Bath temperature does not become stable" page 25.

8.4 Faulty temperature reading or temperature offset

- The temperature readout on the display does not correspond to the temperature measured.

PT100 is defective,

PT100 has aged. Check offset see page

8.5 Bath temperature does not become stable

If the bath temperature does not stabilize after 30 minutes after set point has been reached the following points might cause this problem:

The operating temperature is around or below 30°C. To stabilize the bath at set-points just above the ambient temperature it is necessary to apply cooling water to the cooling coil or to increase or decrease the flow of cooling water through the cooling coil.

If the operating temperature is far above the ambient temperature it is most likely that the viscosity of the bath fluid used is too high. The maximum viscosity of the bath fluid lies below 20 cSt at the operating temperature but is preferably less than 10 cSt. If the viscosity of the bath fluid used is too high the circulating system is incapable to mix it thoroughly resulting in poor stability.

Check PID constant of the bath.

- P) 25
- I) 16
- D) 0

Position of the stirrer fan must be exactly in the center of the hole in the baffle plate (both in horizontal and vertical position).

Check possible heat transfer from additional apparatus close to the bath i.e. oven or central heating.

Check any possible strong magnetic field from other apparatus.

Check overheating of electronics inside apparatus. Cooling fan at backside must run.

Check if stirrer is turning.

8.6 Bath doesn't reach SP

Check menu item MAX power, raise value.



est. 1878

9 Spare parts list

230 Volt 50-60Hz	115 Volt 60Hz	Description
04T0063	04T0163	Stirrer Complete
25T1343	n.a.	Capacitor 2uF
n.a.	25T1344	Capacitor 7uF
28T4022	28T4032	Heater 1500 Watts control
28T4022	28T4022	Heater 1500 Watts boost
24T8081	n.a.	Motor fuse 0.3 Amp.
n.a.	24T8080	Motor fuse 0,6 Amp.
06T0512	06T0522	PCB Mains board with filter and relay
24T8581		Over-temperature protection thermostat
24T8545		Mains switch
24T8546		Protective cover mains switch
28T4009		Front keypad
28T4026		PT-100 sensor
11T0023		Filter 16A Mains

n.a. = Not Applicable

10 Dimensions

Dimensions		
Depth	352 [mm]	(402mm hen drain included)
Width	503 [mm]	
Height	105 [mm]	
Weight*	50 [kg]	
Bath		
Depth	600mm	
Opening	260x240mm	
Power consumption		
Nominal	600 [W]	
Maximum	3000 [W]	
Accuracy		
Standard deviation	0,004 [°C]	Measured with water over 1hr 1 sec interval
Min/Max	0,012 [°C]	Measured with water over 1hr 1 sec interval
Temperature drift		
per year	0,001 [°C]	
per [°C] ambient	0,0005 [°C]	
Homogeneity		
Standard deviation	0,004 [°C]	
Min/Max	0,012 [°C]	

Tamson Instruments bv

Van 't Hoffstraat 12
2665 JL Bleiswijk, The Netherlands
T. 31 (0) 10 522 43 73
F. 31 (0) 10 521 19 41
tv7000mkII-man.doc Rev. 2.1 UK 5-13

E-mail: sales@tamson.com
Website: www.tamson.com

VAT: NL 80 66 34 984 B01
Bank account no.: Rabobank 16 01 00 046
Chamber of commerce 27 16 95 41
IBAN Code: NL95 RABO 0160100046



est. 1878

11 EC DECLARATION OF CONFORMITY THERMOSTATIC BATH TV-SERIES

Manufacturer: **Tamson Instruments BV**
van 't Hoffstraat 12
2665 JL Bleiswijk
The Netherlands

Product: Thermostatic bath

Model: TV7000MKII

We declare that the product mentioned above conforms to the essential's exigency of the directive 2006/42/EC relative to machinery, directives 2004/108/EC relatives to electromagnetic compatibility and directive 2006/95/EC relative to low voltage.

The products are in conformity with the following specifications:

EMC (2004/108/EG)

Conducted emission	- EN55016-2-1 + EN61326+A1
Radiated emission	- EN55016-2-3 + EN61326+A1+A2+A3
Harmonics	- EN61000-3-2
ESD	- EN61326 +A1+A2+A3 and EN61000-4-2 +A1+A2
Radiated immunity	- EN61000-4-3 +A1
Electrical Fast Transients	- EN61000-4-4+A1+A2
Surges	- EN61000-4-5+A1
Conducted immunity	- EN 61000-4-6+A1
Voltage dips and Voltage variations	- EN61000-4-11 +A1

Low voltage (2006/95/EC):

Safety requirements for electrical equipment for measurement, control, and laboratory use Part 1,
General requirements,
EN 61010-1-2010

Safety requirements for electrical equipment for measurement, control, and laboratory use Part 2,
Particular requirements for laboratory equipment for the heating of material,
EN 61010-2-010-2003

Machinery directive (2006/42/EC) 2006-42-ec-2nd-2010

January 2011, Tamson Instruments bv, The Netherlands

Ing. R.C. van Hall
Director

Tamson Instruments bv

Van 't Hoffstraat 12
2665 JL Bleiswijk, The Netherlands
T. 31 (0) 10 522 43 73
F. 31 (0) 10 521 19 41
tv7000mkII-man.doc Rev. 2.1 UK 5-13

E-mail: sales@tamson.com
Website: www.tamson.com

VAT: NL 80 66 34 984 B01
Bank account no.: Rabobank 16 01 00 046
Chamber of commerce 27 16 95 41
IBAN Code: NL95 RABO 0160100046



est. 1878

12 DISCLAIMER

Information given herein is offered in good faith as accurate, but without guarantee. Conditions of use and suitability of the product for particular uses are beyond our control; all risks of use of the product are therefore assumed by the user.

We expressly disclaim all warranties of every kind and nature, including warranties of merchantability and fitness for a particular purpose in respect to the use or suitability of the product.

Nothing is intended as a recommendation for uses which infringe valid patents or as extending license under valid patents. Appropriate warnings and safe handling procedures should be provided to handlers and users. Alteration of this document is strictly prohibited. Except to the extent required by law, republication or retransmission of this document, in whole or in part, is not permitted. Tamson Instruments bv assume no responsibility for accuracy of information. Tamson Instruments neither represent nor warrant that the format, content or product formulas contained in this document comply with the laws of any other country except the Netherlands.

Tamson Instruments bv, All rights reserved.

Tamson Instruments bv

Van 't Hoffstraat 12
2665 JL Bleiswijk, The Netherlands
T. 31 (0) 10 522 43 73
F. 31 (0) 10 521 19 41
tv7000mkII-man.doc Rev. 2.1 UK 5-13

E-mail: sales@tamson.com
Website: www.tamson.com

VAT: NL 80 66 34 984 B01
Bank account no.: Rabobank 16 01 00 046
Chamber of commerce 27 16 95 41
IBAN Code: NL95 RABO 0160100046