



GE Fanuc Automation

Programmable Control Products

***Series 90™-30
PROFIBUS Master Module***

User's Manual

GFK-2121

June 2002

Warnings, Cautions, and Notes as Used in this Publication

Warning

Warning notices are used in this publication to emphasize that hazardous voltages, currents, temperatures, or other conditions that could cause personal injury exist in this equipment or may be associated with its use.

In situations where inattention could cause either personal injury or damage to equipment, a Warning notice is used.

Caution

Caution notices are used where equipment might be damaged if care is not taken.

Note: Notes merely call attention to information that is especially significant to understanding and operating the equipment.

This document is based on information available at the time of its publication. While efforts have been made to be accurate, the information contained herein does not purport to cover all details or variations in hardware or software, nor to provide for every possible contingency in connection with installation, operation, or maintenance. Features may be described herein which are not present in all hardware and software systems. GE Fanuc Automation assumes no obligation of notice to holders of this document with respect to changes subsequently made.

GE Fanuc Automation makes no representation or warranty, expressed, implied, or statutory with respect to, and assumes no responsibility for the accuracy, completeness, sufficiency, or usefulness of the information contained herein. No warranties of merchantability or fitness for purpose shall apply.

The following are trademarks of GE Fanuc Automation North America, Inc.

Alarm Master	Genius	PowerMotion	VersaMax
CIMPLICITY	Helpmate	PowerTRAC	VersaPro
CIMPLICITY 90-ADS	Logicmaster	Series 90	VuMaster
CIMSTAR	Modelmaster	Series Five	Workmaster
Field Control	Motion Mate	Series One	
FrameworkX	ProLoop	Series Six	
GEnet	PROMACRO	Series Three	

Content of This Manual

This manual provides instructions for installing, programming, and troubleshooting control systems that use the Series 90-30 PROFIBUS master module, IC693PBM200. It is assumed that you have a basic understanding of Series 90-30 PLCs and are familiar with PROFIBUS-DP protocol.

Related Publications

Series 90-30 Profibus Slave Module User's Manual, GFK-2193

Series 90-30 Installation and Hardware Manual, GFK-0356.

Series 90-30/20/Micro PLC CPU Instruction Set Reference Manual, GFK-0467

Series 90-30 System Manual, GFK-1411

CIMPLICITY® Machine Edition Getting Started, GFK-1868

Chapter 1	Overview and Specifications.....	1-1
	Overview.....	1-1
	PROFIBUS Information.....	1-1
	Specifications.....	1-3
	PROFIBUS Basics.....	1-4
	PROFIBUS Network Overview.....	1-4
	Bus Communication.....	1-4
	Network Topology.....	1-5
	Network Connectors.....	1-6
Chapter 2	Installation	2-1
	Reviewing System Power Requirements.....	2-1
	Installing the PROFIBUS Module in the PLC Rack.....	2-2
	Connecting the Master to the PROFIBUS Network.....	2-2
	Network Segment Length.....	2-3
	PROFIBUS Cable Types.....	2-4
	Network Termination.....	2-5
	Network Baud Rate.....	2-6
	Removing the Module from the Rack.....	2-6
Chapter 3	Configuration.....	3-1
	Configuring the PROFIBUS Master Module.....	3-1
	Parameters.....	3-5
	Using Sync/Freeze Control.....	3-8
	Example.....	3-8
	Configuring Network Settings for PROFIBUS Master.....	3-9
	General Tab of the Master Properties Dialog Box.....	3-9
	Network Tab of the Master Properties Dialog Box.....	3-10
	Time Sub-Tab of Network Tab.....	3-10
	Parameters Sub-Tab of Network Tab.....	3-11
	Parameters Tab of the Master Properties Dialog Box.....	3-11
	Adding Slave Devices to the IC693PBM200 Master.....	3-13
	Adding Slaves and Modules.....	3-13
	Configuring Module Data Areas.....	3-17
	Data Area Parameters.....	3-17
Chapter 4	Status and Diagnostics	4-1
	PROFIBUS Module LED Indicators.....	4-2
	Slave Status Bit Array.....	4-2
	PLC Fault Table Entries.....	4-3
	Communication Requests.....	4-4
	COMMREQ Ladder Instruction.....	4-4
	Operation of the Communications Request.....	4-5
	COMMREQ Programming Requirements and Recommendations.....	4-6

Contents

Error Detection and Handling	4-6
COMMREQ Status Word	4-7
PROFIBUS Master Module COMMREQ Reference	4-8
Memory Types	4-8
Get Device Status (1)	4-9
Get Device Status Command Block – Basic Example	4-9
Get Device Status Reply Data Format – Response written to location specified by Words 8 & 9	4-10
Get Master Status (2)	4-12
Get Master Status Command Block – Basic Example	4-12
Get Master Status Reply Data Format – Response written to location specified by Words 8 & 9	4-13
Get Device Diagnostics (4)	4-15
Get Device Diagnostics Command Block – Basic Example	4-15
Get Device Diagnostics Reply Data Format – Response written to location specified by Words 8 & 9	4-16
Read Module Header (5)	4-17
Read Module Header Command Block – Basic Example	4-17
ReadModuleHeader Reply Data Format for Master	4-19
Clear Counters (6)	4-20
Clear Counters Command Block – Basic Example	4-20
ClearCounters Reply Data Format	4-21

Chapter 1

Overview and Specifications

Overview

The Series 90-30 PROFIBUS Master (scanner) module allows the host Series 90-30 CPU to send and receive I/O data from a PROFIBUS-DP network. Its features include:

- supports all standard data rates
- supports a maximum of 125 DP slaves
- supports 244 bytes of input and 244 bytes of output for each slave
- supports Sync and Freeze modes
- has PROFIBUS-compliant Module and Network Status LEDs
- provides an RS-232 serial port (the Service port) for upgrading the firmware

PROFIBUS Information

Please refer to the following sources for PROFIBUS information:

- PROFIBUS standard DIN 19245 parts 1 (low-level protocol and electrical characteristics) and 3 (DP protocol)
- European standard EN 50170
- ET 200 Distributed I/O system, 6ES5 998-3ES22
- IEEE 518 Guide for the Installation of Electrical Equipment to Minimize Electrical Noise Input to Controllers

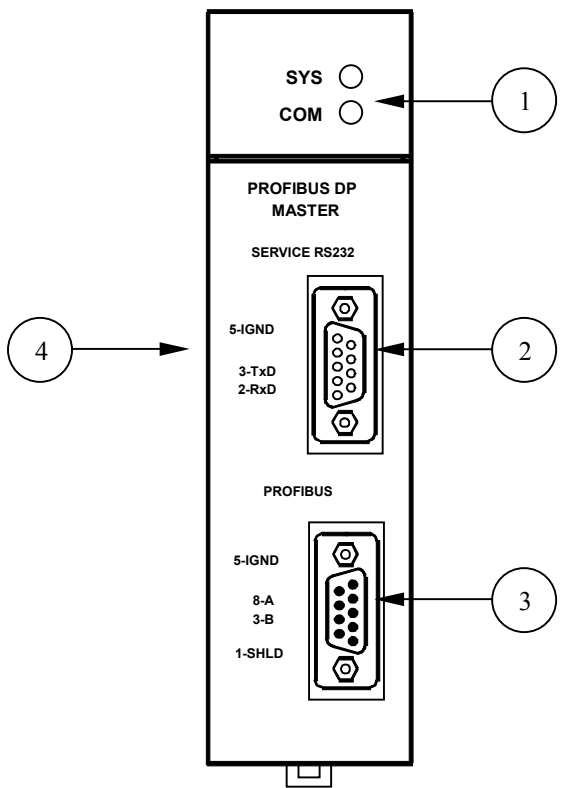

IC693PBM200
Profibus Master
Module

Key

1	LEDs System (SYS) and Communications (COM) indicators
2	Service Port RS232, 9-pin male, D-shell connector. Used for module firmware upgrades.
3	PROFIBUS Port 9-pin female D-shell connector. Used for connecting to a PROFIBUS network.
4	Label (not shown, on side of module) Contains catalog number, description, standard conformance, and serial number information

Figure 1-1. PROFIBUS Master Module

Specifications

Catalog Number	IC693PBM200
Description	Series 90-30 Master module for PROFIBUS DP networks
Configuration Software Requirement	CIMPLICITY Machine Edition Logic Developer version 2.6 or later
CPU Version Requirement	CPU firmware version 8.00 or later
Mounting Location	Any Series 90-30 baseplate (CPU, expansion, or remote) slot except slot 1 of a modular CPU baseplate
Environment	Storage temperature = -40°C to 85°C Operating temperature = 0°C to 60°C
Backplane Current Consumption	450mA @ 5VDC (typical)
Data rates	Supports all standard data rates (9.6K, 19.2K, 93.75K, 187.5K, 500K, 1.5M, 3M, 6M and 12M Baud)
Status Information Available	Slave Status Bit Array table Network diagnostic counters DP master diagnostic counters Firmware module revision Slave Diagnostic Address

PROFIBUS Basics

PROFIBUS Network Overview

- PROFIBUS is an open, vendor independent FieldBus standard for a wide range of applications in industrial automation, including motion control.
- PROFIBUS is a dynamic technology that grows functionally while complying with the European FieldBus Standard EN 50 170.
- PROFIBUS Guidelines and Profiles provide the means for further technical development based on the ever-changing communication requirements of the networks, systems, and devices used in today's industrial automation applications.

PROFIBUS specifications reference three different protocols to cover a range of industrial requirements:

- *PROFIBUS-DP* High speed data communication. DP stands for *Decentralized Periphery*. In practice, the majority of slave applications are DP applications.
- *PROFIBUS-FMS* Object oriented general-purpose data communication. FMS stands for *FieldBus Message Specification*. FMS protocol devices may exchange data on the same bus used for DP devices.
- *PROFIBUS-PA* Meets requirements for intrinsic safety and non-intrinsic safety areas and includes bus powered field devices.

Note: The PROFIBUS logo is a registered trademark of the PROFIBUS International Organization. Membership in the organization is open to all individuals, companies and organizations. More information about the organization and the protocol is available at <http://www.profibus.com>

Bus Communication

The PROFIBUS specification defines the technical characteristics of a serial field bus system that links distributed digital controllers on the network, from field level to cell level. PROFIBUS is a multi-master system that allows the joint operation of several automation, engineering or visualization systems with their distributed peripherals on one bus. PROFIBUS distinguishes between the following types of devices:

- **Master devices** determine the data communication on the bus. A master can send messages without an external request when it holds the bus access rights (the token). Masters are also called active stations.
- **Slave devices** include motion controllers, drives, I/O devices, valves, and transducers. Slaves do not have bus access rights and can only acknowledge received messages or send messages to the master when requested to do so. Slave devices are passive stations and require only small portions of the bus protocol.

The majority of PROFIBUS-DP applications are located at the field level. The field level typically includes slave devices such as the S2K motion controller station and host devices like PLC or PC control systems for the PROFIBUS-DP master station. Operator interfaces and DCS type systems usually operate at the cell level.

Table 1-1. Data bandwidth Demands on PROFIBUS Communications Systems

	Amount of Data	Transmission Duration	Transmission Frequency
Management level	Mbytes	Hours/Minutes	Day/Shift
Cell level	Kbytes	Seconds	Hours/Minutes
Field Level	Bytes	Several 100 microseconds to 100 milliseconds	10 to 100 milliseconds
Actuator sensor level	Bits	Microseconds to milliseconds	Milliseconds

Network Topology

A PROFIBUS-DP network may have up to 127 stations (address 0-126), however address 126 is reserved for commissioning purposes. The bus system must be sub-divided into individual segments to handle this many participants. These segments are linked by repeaters. The function of a repeater is to condition the serial signal to allow connection of segments. In practice, both regenerating and non-regenerating repeaters may be used. Regenerating repeaters actually condition the signal to allow increased range of the bus. *Up to 32 stations are allowed per segment and the repeater counts as a station address.*

A specialized “link” segment consisting only of optical fiber modem repeaters may be used to span long distances. Plastic fiber optic segments are typically 50 meters or less while glass fiber, optic segments may extend several kilometers.

The user assigns a unique PROFIBUS station address to identify each master, slave, or repeater in the entire network. Each participant on the bus must have a unique station address.

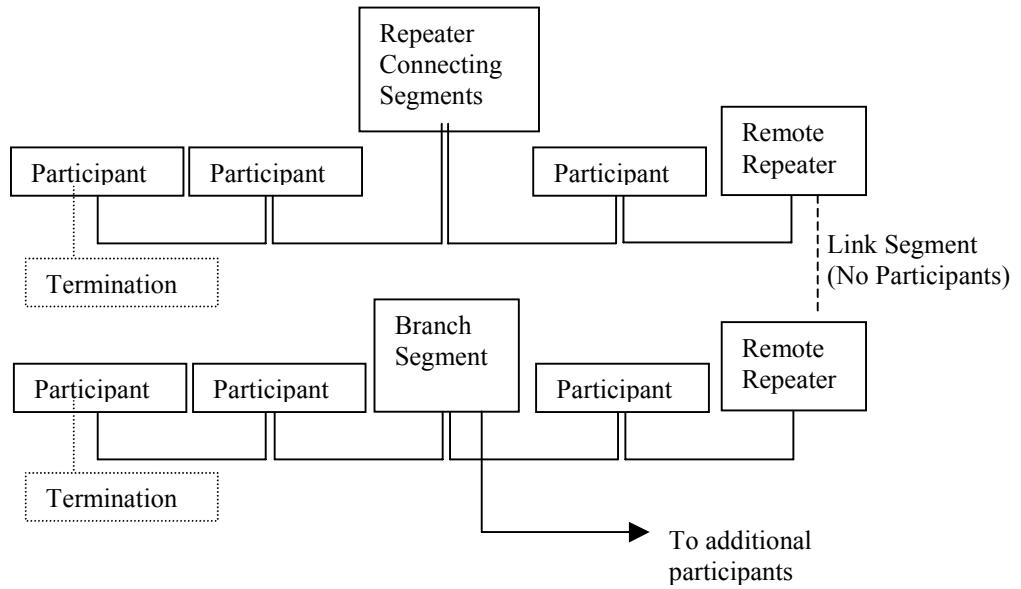

Figure 1-2. Repeaters and bus termination

Network Connectors

PROFIBUS connections are typically created with a 9-pin sub-D connector. Other connectors are used for IP67 devices. A minimum connection consists of a shielded twisted-pair cable (shield to pin 1 and twisted-pair wires to pins 3 and 8) with terminating connections in the appropriate bus plugs. The pin to signal conventions for a 9-pin sub-D connector are described below.

Table 1-2. Pin-out Listing for the PROFIBUS Bus Plug Connector

Pin No.	Signal	Designation
1	Shield	Shield / Protective Ground
2	M24	Ground / Common of the 24V output voltage
3	RxD/TxD-P	Receive data / transmission data plus
4	CNTR-P	Control signal for repeaters (direction control)
5	DGND	Data transmission potential (ground to 5V)
6	VP	Supply voltage of the terminating resistance (+ 5V)
7	P24	Output voltage (+ 24V)
8	RxD/TxD-N	Receive data / transmission data negative
9	CNTR-N	Control signal for repeaters (direction control)

Note: For information on network segment length, network connectors and network termination, and network baud rate, refer to Chapter 2, “Installation.”

Chapter 2

Installation

This chapter contains information on the following procedures:

- Reviewing system power requirements
- Installing the PROFIBUS module in the PLC rack
- Installing PROFIBUS wiring
 - Connecting the Master to the PROFIBUS network
 - Selecting the proper line type
 - PROFIBUS cable types
 - Installing bus termination

Reviewing System Power Requirements

Review the power requirements of your system to ensure that your power supply has sufficient capacity to support the PROFIBUS Master. Power supply load is automatically calculated by the SIMPLICITY Machine Edition configuration software. Details on manually calculating power supply load can be found in GFK-0356, the *Series 90-30 Installation and Hardware Manual*.

Note: High capacity Series 90-30 power supplies IC693PWR330 or IC693PWR331 are recommended, particularly for systems with CPU350 or higher, or that have Ethernet adapters and/or multiple PROFIBUS modules. The Series 90-30 PROFIBUS Master module consumes 450mA at 5VDC (typical).

Installing the PROFIBUS Module in the PLC Rack

1. Remove power from Series 90-30 rack.
2. Turn off power to rack.
3. Place the module into slot 1 or higher in the rack (slot 2 or higher in the Main rack) by hooking the top of the module on the notch above the slot and slowly lowering the module until it snaps into place.
4. Attach the PROFIBUS cable and terminate as required.

Note: For details about installing Series 90-30 rack systems and modules, refer to the *Series 90-30 Installation Manual and Hardware Manual*, GFK-0356.

Connecting the Master to the PROFIBUS Network

The module contains a standard female DB9 connector, labeled “PROFIBUS,” that can be connected to a PROFIBUS bus terminal.

- **PROFIBUS DB-9 connector recommendation:** Siemens 6ES7-972-OBB50-OXAO (12MB)

Table 2-1. Pin-out Listing for PROFIBUS Connector

Pin #	Pin Description	DB9 Line * Termination
1	rack ground	
2	reserved	
3	data +	connect this pin to pin 8 (data -) with 220 ohm resistor
4	TX Enable	
5	Isolated ground	connect this pin to pin 8 (data -) with 390 ohm resistor
6	Isolated +5V	connect this pin to pin 3 (data +) with 390 ohm resistor
7	reserved	
8	data -	
9	reserved	

* For line A cable (135-165 ohm impedance)

The module has no built-in termination. If you require termination, you must use a bus terminal that has built-in selectable termination.

Warning

Do not connect any devices to the +5V pin (pin 6). It is to be used for termination purposes only.

Network Segment Length

A PROFIBUS network uses either fiber optic or RS-485 copper media. The copper bus line specified in EN 50 170 is “Line Type A” and is the recommended cable type. A more economical copper cable “Line Type B” is commonly used for smaller installations; however, it is not specified in EN 50 170. It is extremely important to use cable rated to PROFIBUS specifications. The higher the baud rate selected and the longer the distances involved, the more critical cable selection becomes. (PROFIBUS cable has a distinctive purple color.)

Stub or “T” type branch connections are supported if the total stub (branch) lengths do not exceed 6.6 meters. Do not use stubs at all on 12 Mbaud networks.

The data rates for network communication with maximum segment trunk length per cable type are provided below. Multiple segments may be connected via repeater stations to extend the total bus length.

Table 2-2. Line Types

Baud Rate	Line A Distance (Max) ^{1, 2}	Line B Distance (Max) ^{1, 2}	Glass Fiber
9.6KBps, 19.2KBps and 93.75KBps	1200 m	1200 m	6Km
187.5KBps	1000 m	600 m	6Km
500KBps	400 m	200 m	6Km
1.5MBps	200 m	NA	6Km
3, 6 and 12MBps	100 m	NA	6Km

¹ If using a combination of both line types, divide the lengths shown by two.

² Values shown are the sum of all bus segment and drop cable lengths.

NA = Not Applicable

Termination Note: The two physical ends of the PROFIBUS network should be terminated. There should be two, and only two, terminators on a network.

PROFIBUS Cable Types

The recommended cable is:

- Belden 3079A PROFIBUS cable

This is a shielded, 150 ohm twinaxial (single twisted pair) cable. It has 22 AWG conductors and a mutual capacitance of 9.0pF per foot, nominal. For complete specifications on this cable, please contact your Belden dealer or visit their website at www.belden.com.

Alternate cable types are:

- Siemens 6XV1 830-OAH10 Two Core shielded
- Siemens 6XV1 830-OBH10 w/PE Sheath
- Siemens 6XV1 830-3AH10 for underground burial
- Siemens 6XV1 830-3BH10 trailing cable
- Bosch Comnet DP #913 548 Flexible PROFIBUS cable
- Bosch Comnet DP #917 201 Trailing PROFIBUS Cable
- Bosch Comnet DP #917 202 Massive PROFIBUS Cable

Note: Allen Bradley “blue hose,” which has an impedance of 78 ohms, is *not* recommended for this application.

Table 2-3. Cable Specifications

Cable Parameter	Type A	Type B
Impedance	135 to 165 ohms f = 3 to 20MHz	100 to 130 ohms f > 100KHz
Capacitance	<30pF/m	<60pF/m
Resistance	<110 W/Km	-
Conductor area	0.34mm ² (22 AWG)	0.22mm ² (24 AWG)

Network Termination

Termination resistors are needed, as defined in DIN 19245 Part 1 section 3.1.2.5.

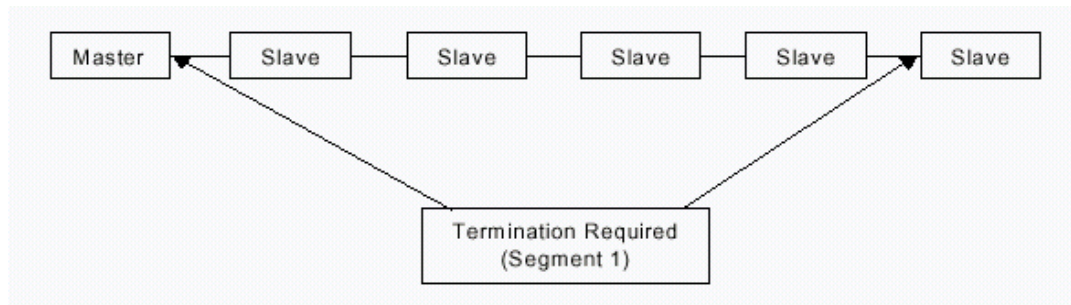

One terminator must be applied at each end of a network segment.

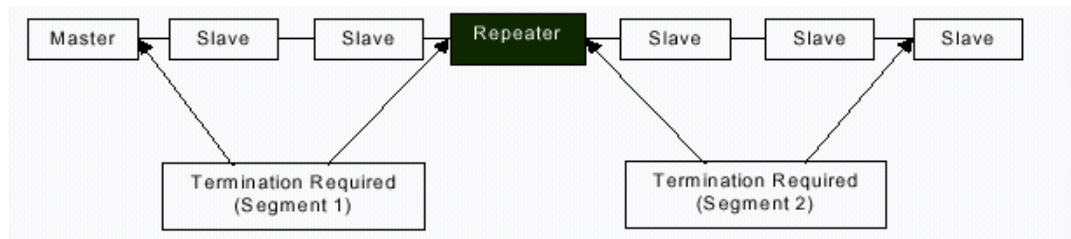

Generally, termination is provided in commercially-available PROFIBUS standard network connectors. Some connector vendors provide termination capability in the connector and a switch on the connector to enable/disable termination. Some connector vendors provide both terminated and unterminated connectors.

Important: For proper network termination, it is essential that the terminating devices maintain power. Power is provided by the device on Pin 6 and Ground on Pin 5. If power is lost to either terminating device, the network may not operate correctly. Generally, the lone network master device is one of the terminating devices. Therefore, a loss of power to the network master renders the network inoperable anyway. The other terminating device may be a critical slave device which must maintain power or a separately powered, stand-alone terminator. These stand-alone devices are commercially available.

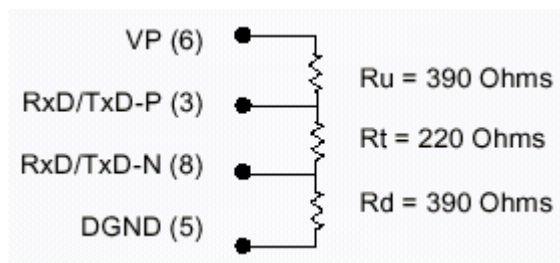

Figure 2-1. Bus Termination for Type A Cable in Accordance to PROFIBU Specifications

In addition to the termination shown in figure 2-1, the following compensation should be added for 12 Mbit bus technology:

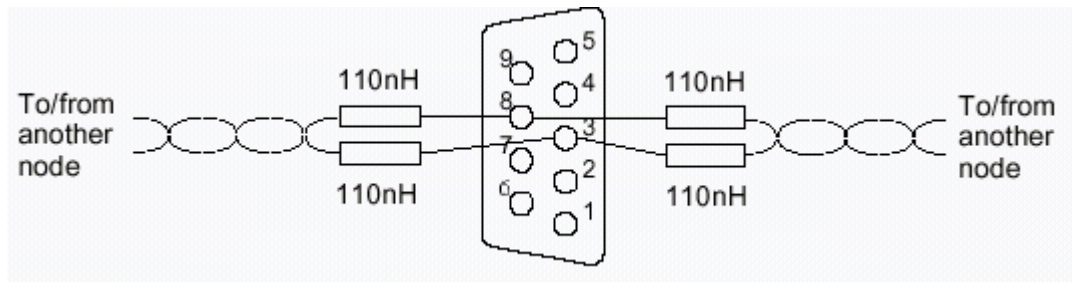

Figure 2-2. 12 Mbit Bus Compensation

Network Baud Rate

The master configures the appropriate network baud rate for each station on the network. Typical baud rate values are: 9.6KBps; 19.2KBps; 45.45KBps; 93.75KBps; 187.5KBps; 500KBps; 1.5MBps; 3MBps; 6MBps; or 12MBps. For details on using the configuration software, refer to chapter 3.

Removing the Module from the Rack

The following procedure describes how to remove a module from the Series 90-30 rack:

1. Turn off power to rack.
2. Remove all cabling from the module.
3. Press the release located on the bottom of the module and slowly raise the module from the bottom until it comes out of the slot.

Chapter 3

Configuration



These configuration procedures are written for users with at least a basic knowledge of the CIMPPLICITY Machine Edition Logic Developer software and the Series 90-30 PLC. For help with using the software, please see the software's built-in help system.

Note: The PROFIBUS Master is only supported in CIMPPLICITY Machine Edition Logic Developer. The following software packages do not support the PROFIBUS Master: Logimaster™, VersaPro™, and Control software.

Note: The PROFIBUS Master module does not support redundant masters.

Configuring the PROFIBUS Master Module

Add the IC693PBM200 module to the PLC rack configuration.

1. In the  Project tab of the Navigator,  expand the  Hardware Configuration folder.
2. In the Hardware Configuration folder, right click the PLC Slot where you wish to install the PROFIBUS Master module. Note that a PROFIBUS module is not a valid choice for slot 1 of a modular CPU rack.

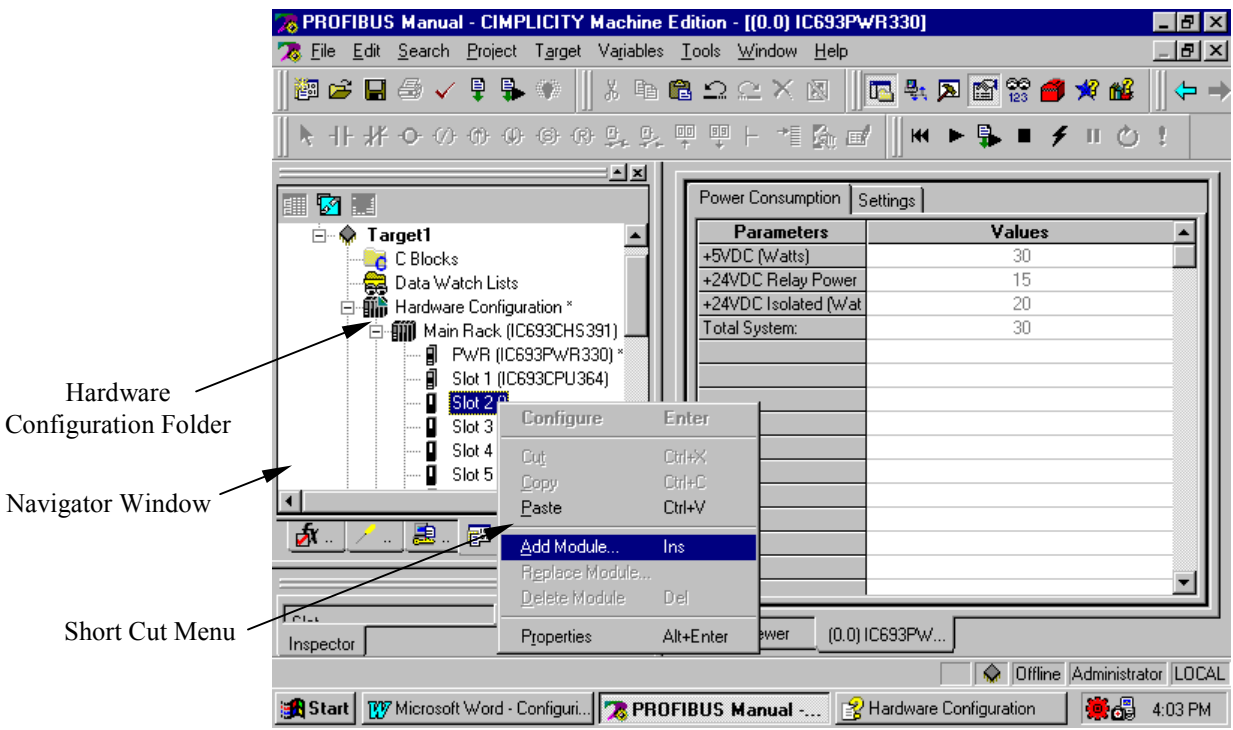

Figure 3-1. Adding a Module

3. Select Add Module from the shortcut menu. The Module Catalog dialog box appears.
 - Note:** To edit a module that already appears in the rack, right click the module and select Configure. The module’s Parameter Editor window opens.
4. Click the Bus Controller tab. The Bus Controller module list appears.

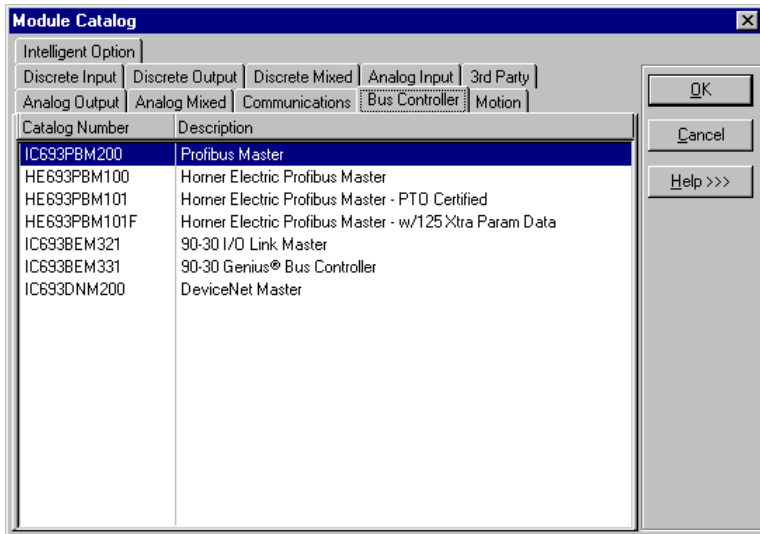

Figure 3-2. The Module Catalog Window’s Bus Controller Tab

5. Select the IC693PBM200 PROFIBUS Master and click the OK button. The module is added to the PLC configuration in the Navigator window, and the module’s Parameter Editor window appears in the InfoViewer window space.

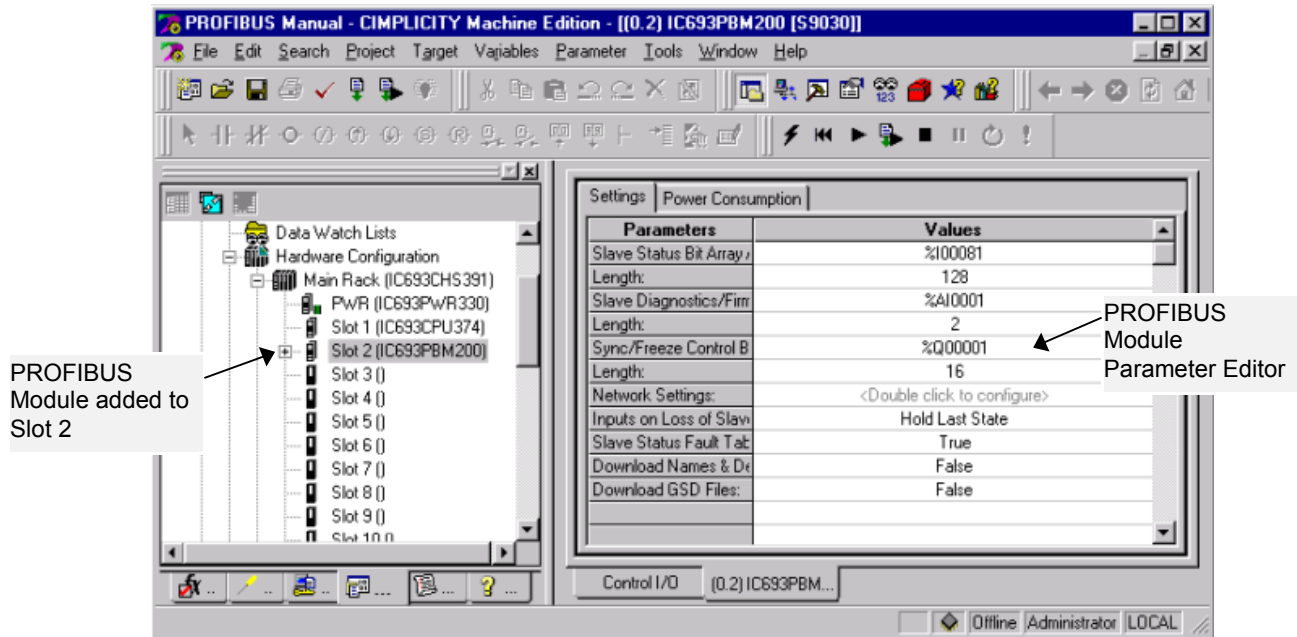

Figure 3-3. The PROFIBUS Master Parameter Editor Window

- In the Configuration window, double click a parameter in its Values column to open its dialog box. For example, the next figure shows the result of double clicking the Slave Status Bit Array Address parameter.

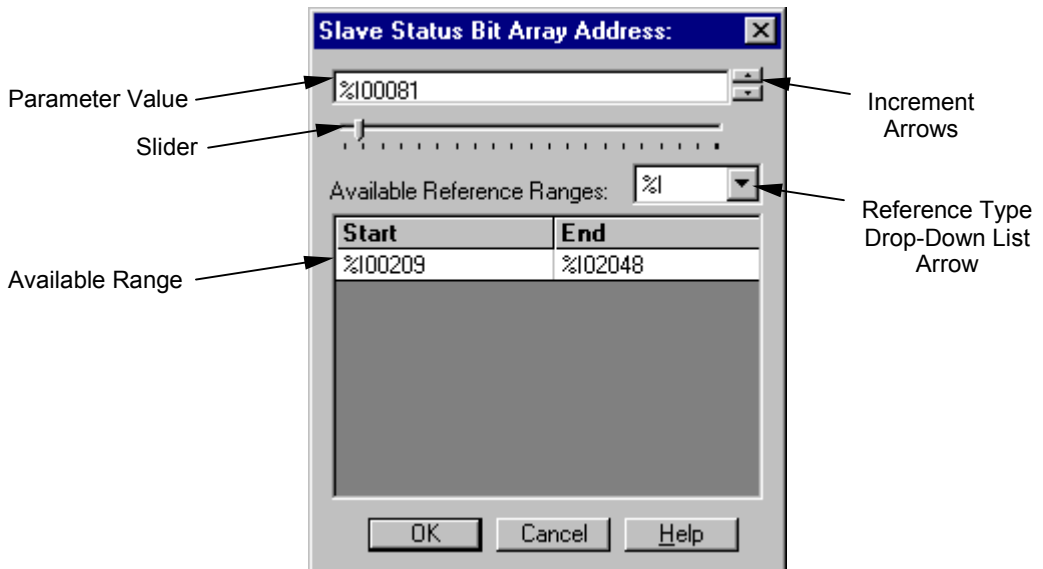

Figure 3-4. Typical Parameter Value Dialog Box

Note: To change a value in a parameter’s dialog box, such as the one shown above, you can (1) type in a different value, (2) use the Increment Arrows at the right end of the address field,

or (3) drag the Slider below the address field. To change the reference type (such as %I, %Q, %R, etc.), click the arrow at the right end of the Available Reference Ranges box and select a reference type from the drop-down list. When done, click the OK button to verify your changes.

Parameters

Settings tab	
Slave Status Bit Array Address	<p>The Slave Status Bit Array is an array of bits indicating the health of each node on the PROFIBUS network. This parameter is the starting address for the array of slave status bits. Slave Status Bit Array Address is a consumed range and as such must be a non-overlapping range in %AI, %I, %Q, %G, %AQ, %R, %T, or %M. It defaults to %I memory.</p> <p>A slave's status address equals Start Address + Station Address of the slave. For example, if the status bits are mapped to %I00001, the status for the slave at Station Address 5 would be found at %I00001 + 5=%I00006.</p> <p>The master's status is located in the same way as the slaves' (Start Address + Station Address). The master is configured as station 0 by default, but can be set to any valid address (0-125).</p> <p>Tips:</p> <ul style="list-style-type: none"> ■ To change the master's Station Address, right click the master and choose Network Settings. To change a slave's Station Address, right click the slave and choose Configure. The Station Address parameter is located on the General tab of the Properties dialog box. ■ Use the Communication Request task 1 (GetDeviceStatus) or task 2 (GetMasterStatus) to retrieve the status information that is reported in this memory area. For details, see "Communication Requests" in chapter 4.
Length (of slave status bit array)	<p>For discrete memory, Length can be any multiple of 16 between the values of 16 to 128. The entered value is automatically rounded up to the next multiple of 16. The default is 128, which contains all possible status bits, since 126 (125 Slaves + master) is the maximum number of stations on the PROFIBUS network.</p> <p>For word memory (16-bit memory) types, Length can be 1 through 8.</p> <p>Note: To conserve PLC memory space, you may reduce the Slave Status Bit Array Length from the default of 128. The Slave Status Bit Array length actually required depends on the highest address on your network. For example, if 29 is your highest address station, and you are using a discrete memory type for slave status memory, the Slave Status Bit Array length could be set to 32. It cannot be set to 29 because Slave Status Bit Array length values must always be multiples of 16 (16, 32, 48, 64, etc). If you were using word type memory in this example, you would set Length to 2 (2 words = 32 bits).</p>
Slave Diagnostics/Firmware ID Address	<p>The starting address for this two-word array. The Slave Diagnostic is the first word, The Firmware ID is the second word. Slave Diagnostic/Firmware ID Address is a consumed range and as such must be a non-overlapping range in %AI, %I, %Q, %G, %AQ, %R, %T, or %M. Defaults to %AI memory.</p> <ul style="list-style-type: none"> • The Slave Diagnostics word provides a way for the master module to inform the host (the CPU of the PLC that the master resides in) that there are diagnostics pending. If there are diagnostics pending, the module places the address of the first slave that has diagnostics into the Slave Diagnostics word. The diagnostics can be read using the GetSlaveDiagnostics mailbox message via a Communications Request. This clears the field and the module then places the next pending diagnostic address into the Slave Diagnostics field. If the field is zero there are no pending interrupts. • The Firmware ID word contains the current firmware version running on the master module. This information is in HEX format. The Major Revision number resides in the upper byte and the Minor Revision number resides in the lower byte of this word. <p>Tip: Use the Communication Request task 4 (GetSlaveDiagnostics) to retrieve the information that is reported in this memory area.</p>

Length (of slave diagnostics/firmware ID array)	For discrete memory, Length can be in the range 0 ,16,or 32. For word-type memory, Length can be in the range 0, 1, or 2. Slave Diagnostics/Firmware ID Length defaults to 2 to include both the Slave Diagnostic area and the Firmware ID. Setting Length to 1 will provide only the Slave Diagnostic.
Sync/Freeze Control Bits Address	<p>Defines the reference areas for the Sync/Freeze command data. Sync/Freeze Control Bits Address is a produced range and must be a non-overlapping range in %AI, %I, %Q, %G, %AQ, %R, %T, or %M. Defaults to %Q memory.</p> <p>Sync and Freeze are global control functions used to synchronize remote I/O stations. You can use these functions to cause a group of slaves to operate at the same time in your system. (For additional information, see “Using Sync/Freeze Control” on page 3-8.</p> <ul style="list-style-type: none"> ■ The Sync command is used to control a slave’s outputs. When a slave receives a Sync command, it holds its last output data to the master until the slave receives another sync command from the master. ■ Freeze is used to control a slave’s inputs. When a Freeze command is sent to a slave, the slave freezes its current inputs and does not accept any new input data until it receives another Freeze command.
Length (of sync/freeze control bits)	For discrete memory, Length can be 0 or 16 and defaults to 16. For word-type memory, Length can be 0 or 1 and defaults to 1.
Network Settings	Double-clicking this field opens the Master Properties dialog box. This dialog box is discussed in “Configuring Network Settings.”
Inputs on Loss of Slave	Determines the values that the master module reports for a particular slave if communications between master and slave are lost. Choices are Hold Last State (default) and Clear.
Slave Status Fault Table Entries	If set to True (default), slave communications status events (loss and re-establish) are reported as fault table entries. If set to False, slave status events are not reported to the fault table.
Download Names/Descriptions	If set to True, names and descriptions for the slaves and the master are sent to the PLC and do not revert to default upon uploading.
Note:	Downloading names and descriptions may take up too much memory in the PLC. It is recommended that this parameter remain set to False (Default). Names and descriptions are a convenience only. Omitting them from the download does not affect system operation.

Download GSD Files	<p>Determines whether a <i>Full Upload</i> or <i>Generic Upload</i> can be performed from the downloaded configuration.</p> <p>If you set this parameter to False (default), GSD files are not downloaded to the PLC. Subsequent upload operations are Generic.</p> <p>If set to True, the GSD files required by the network configuration are sent to the PLC. Subsequent upload operations are Full uploads.</p> <p>Full Upload -- A full upload of a hardware configuration containing a PBM200 has the following characteristics:</p> <ul style="list-style-type: none">Occurs if Download GSD Files is set to True on download.You have full configuration capability, including adding slaves and adding new modules to existing slaves.The Toolchest is populated with GSD files from the uploaded configuration, allowing you to add more of an existing slave to the configuration.Download/upload of text fields, such as descriptions, is controlled by the Download Names/Descriptions parameter. <p>Generic Upload -- A generic upload of a hardware configuration containing a PBM200 has the following characteristics:</p> <ul style="list-style-type: none">Occurs if Download GSD Files is set to False (default) on download.If the project is uploaded from the PLC and the GSD files are in the Toolchest, the network is rebuilt. If the GSD files that were used to build the network are not present in the Toolchest, the network is rebuilt but new modules cannot be added to the slaves.Existing slaves for which there is no GSD file in the Toolchest are made generic. You cannot add or remove modules under the generic slave. The following operations can be performed on a generic slave:<ul style="list-style-type: none">- Change its station number.- Edit its parameters in hex mode.- Delete the slave.New, fully functioning slaves can be added from GSD files in the Toolchest. <p>Note: Downloading GSD files may consume too much memory in the PLC. It is recommended that this parameter remain set to False (default).</p>
Power Consumption tab	<p>The information in this tab is read-only. It indicates the power consumed by the module from the PLC backplane.</p>

Using Sync/Freeze Control

The Sync/Freeze control is optional, two bytes in length, and the default is to map to the first available address in %Q . The Sync/Freeze control can be mapped to any PLC memory area and must have a length of either 16 bits if mapped to discrete PLC memory (%Q, %I, %T, %M, %G) or, one word if mapped to Word PLC memory (%AI, &AQ, %R).

To use the Sync/Freeze control, you need to specify a Group Select and a command.

Note: The Series 90-30 PROFIBUS Slave Module (IC693PBS201) does not support receipt of Sync/Freeze commands.

Group Select

The Group Select, which specifies which group of slaves to send this command to, is specified in the LSB (bits 1 through 8). Each slave can be in one or more groups (0 through 7) and is selected on the Parameters tab of the slave .

Command

The command is specified in the MSB (bits 9 through 16).

The command can be one of the following (HEX):

UNFREEZE=0x04

FREEZE=0x08

UNSYNC=0x10

SYNC=0x20

TRIGGER=0x80*

* Indicates the most significant bit used to trigger the command to be sent.

Example

If you wanted to send a SYNC command to all the slaves with group ID 04, you would write 0x04 to the location starting at byte 1 and 0x20 to the byte location starting at byte 9.

To actually send this command, toggle the trigger bit of the command (byte 16).

Configuring Network Settings for PROFIBUS Master

To configure network settings for the master, double-click the Network Settings field in the Parameter Editor Settings tab. The Master Properties dialog box opens.

Note: You can also open this dialog box by selecting the Project tab of the Navigator and expanding the Hardware configuration folder and the rack that contains the module. Right click the slot containing the IC693PBM200 module, and choose Network Settings.

General Tab of the Master Properties Dialog Box

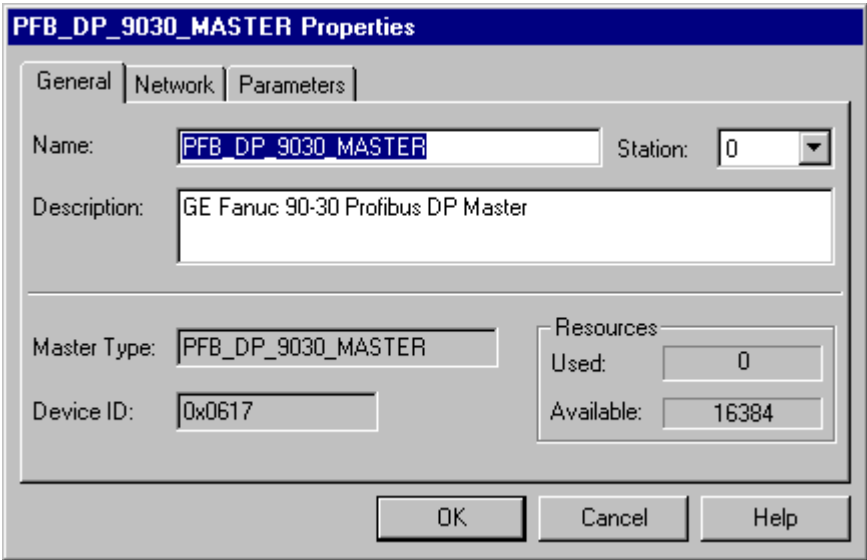

Figure 3-5. General Tab of MASTER Properties Dialog Box

Name	The name assigned to the PROFIBUS Master. You can edit the name or use the default name. The name appears in the title bar of the dialog box (in the figure above, the default name is PFB_DP_9030_MASTER).
Station	The address of the PROFIBUS Master module on a PROFIBUS DP network. The master module is configured as Station 0 by default. In a multiple master configuration, you can share station numbers between the master and slaves of the same type that are configured in another master device.
Description	A optional user-defined description for the PROFIBUS Master device. The Inspector displays a maximum of 254 characters. However, more than 254 characters can be entered in the dialog box.
Master Type	The type of PROFIBUS Master device. This is a read-only field.
Device ID	The ID of the PROFIBUS Master device. This is a read-only field.
Resources - Used	The number of bytes used by the PROFIBUS Master device. This is a read-only field.
Resources - Available	The number of bytes available for use by the PROFIBUS Master device. The maximum resource size is 16382 bytes. The amount of available resources depends on the PROFIBUS slave(s) that are configured and each slave's modules, parameters, and diagnostic messages. This is a read-only field.

Network Tab of the Master Properties Dialog Box



Figure 3-6. Network Tab of MASTER Properties Dialog Box

Network parameters are automatically set. This tab provides additional configuration for advanced users.

Baud rate	The baud rate of the PROFIBUS network. The choices are 9.6 Kbps, 19.2 Kbps, 93.75 Kbps, 187.5 Kbps, 500 Kbps, 750 Kbps, 1.5 MBps, 3 MBps, 6 MBps, 12 MBps. Default is 1.5 MBps.
Highest Station	The highest possible station address for any active station on the network. This affects how much time is spent soliciting for new PROFIBUS Master devices. Default is 126.
Token Rotation Time	The maximum target token rotation time for the network, expressed in t_bits (and milliseconds).

Time Sub-Tab of Network Tab

Slot	The amount of time (microseconds) the PROFIBUS Master waits for a reply to a message.
Idle 1	The amount of time (microseconds) the PROFIBUS Master waits after it receives a reply or an acknowledgement.
Idle 2	The amount of time (microseconds) the PROFIBUS Master waits after sending a message and before sending another message.
Ready	The number of t_bits the PROFIBUS Master waits before sending an ACK response, after sending a command.
Quiet	The number of t_bits the PROFIBUS Master waits after it turns on its transmitter, before it begins to send data.

Parameters Sub-Tab of Network Tab

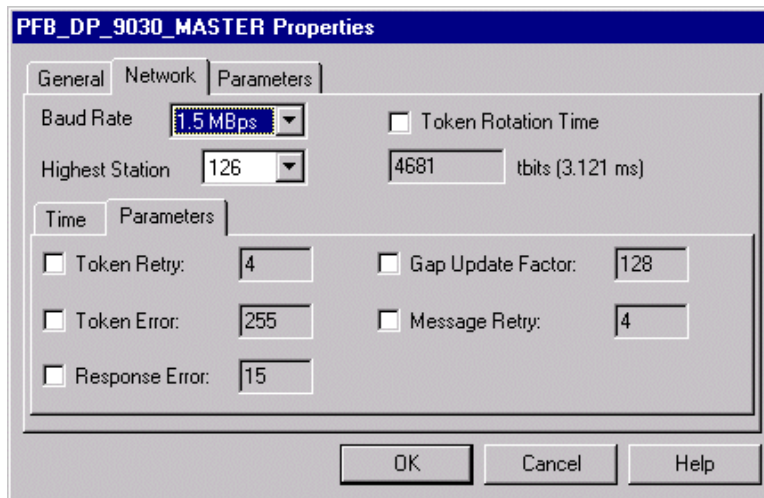

Token Retry	The number of times the PROFIBUS Master tries to pass the token before deciding that a station is not there.
Token Error	The maximum number of errors in 256 token cycles.
Response Error	The maximum number of message failures in 16 successive messages.
Gap Update Factor	The number of token rotations between solicitations for a new PROFIBUS Master card.
Message Retry	The maximum number of times the PROFIBUS Master tries to send a message when the slot time expires.

Parameters Tab of the Master Properties Dialog Box

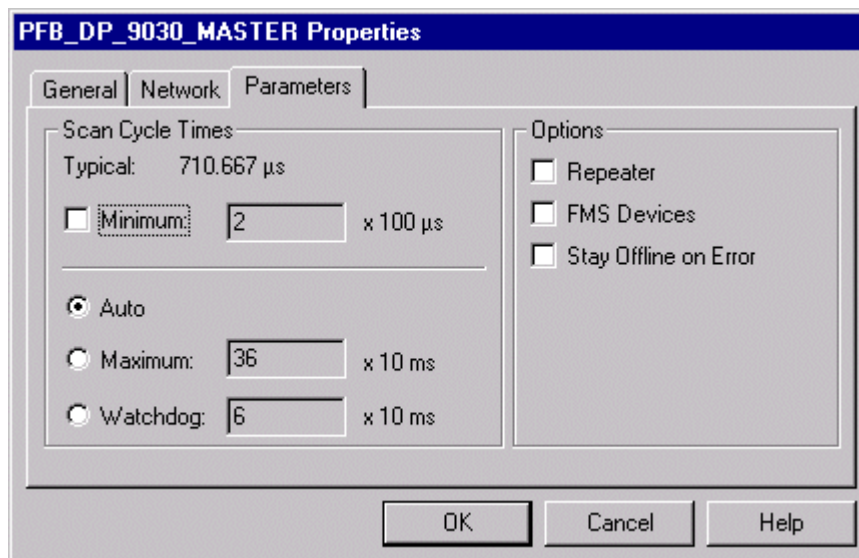

Scan Cycle Times	
Typical	This field displays the estimated time (μ s) required for one scan of the PROFIBUS network. This is a read-only field.
Minimum	The minimum I/O scan time in 100 microsecond increments. This may be required if the I/O modules are restricted in how often they can be scanned. To use this parameter, click the Minimum check-box to activate it, then enter the value in the field next to it. The value you enter here represents the number of 100 microsecond increments. For example, in the figure above, the value is $2 \times 100 = 200$ microseconds.
Scan Cycle Times Parameter Group	These parameters allow you to set minimum and maximum scan cycle times for the Watchdog timer.
Auto	The maximum I/O scan time and Watchdog timer are assigned automatically.
Maximum	The maximum I/O scan time in 10 millisecond increments. If the scan time exceeds this value, the PROFIBUS Master faults all the slaves, reinitializes them, and brings them back online. When the maximum I/O scan time is updated, the Watchdog timer is also updated.
Watchdog	If a PROFIBUS Slave does not receive any communication from its master within the Watchdog time, the Slave generates a fault, the outputs are set to 0, and the Slave is reinitialized by the PROFIBUS Master card. Assigning a value affects the maximum cycle time.
Options Parameter Group	
Repeater	Select this check box if there are repeaters on the network.
FMS Devices	Select this check box if there are PROFIBUS FMS (FieldBus Message Specification) devices on the network.
Stay Offline on Error	Select this check box if you want the PROFIBUS Master to stay offline when the Token Error Limit or response Error Limit is exceeded within 256 token cycles.

Adding Slave Devices to the IC693PBM200 Master

Adding Slaves and Modules

1. In the Navigator window, right click the IC693PBM200 Master module and choose Add Slave. The Slave Catalog dialog box appears.

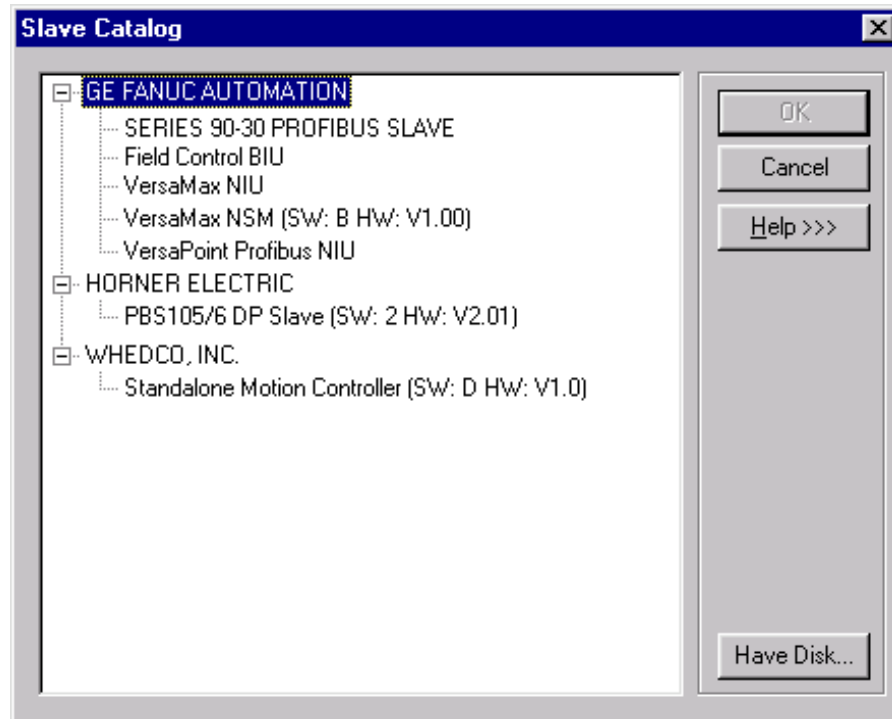

2. Select a Slave device and click OK. The Slave Properties dialog box opens.

Note: If the Slave module is not in the list but you have a GSD file, click the “Have Disk” button.

Note: The following figures use the IC693PBS201 PROFIBUS Slave module as an example.

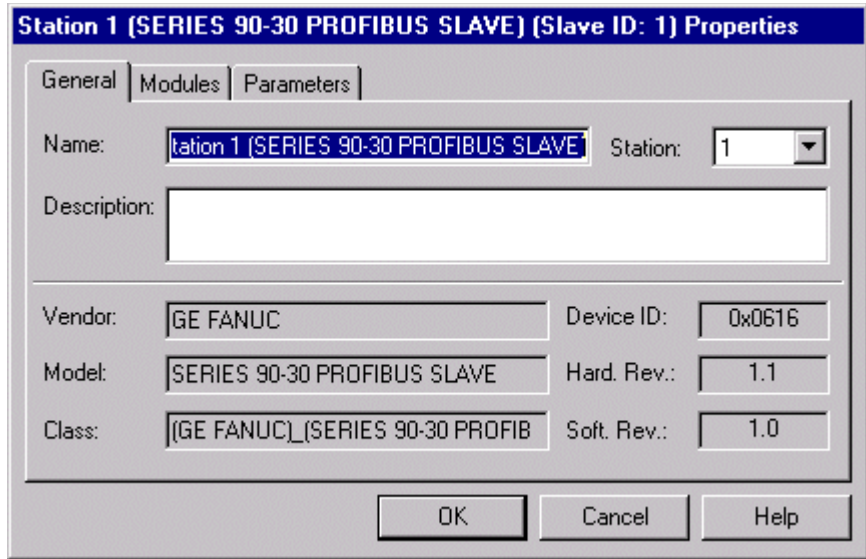

Name	The name assigned to the Slave. You can edit the name or use the default name. The name appears in the title bar of the dialog box (in the figure above, the default name is Station 1 (SERIES 90-30 PROFIBUS SLAVE)).
Station	The address of the Slave on a PROFIBUS DP network. The Slave module is defaulted to the next highest available address.
Description	A optional user-defined description for the Slave device. The Inspector displays a maximum of 254 characters. However, more than 254 characters can be entered in the dialog box.
Vendor	The manufacturer of the Slave device, from the GSD file. This is a read-only field
Device ID	The ID of the PROFIBUS device. This is a read-only field.
Model	The model of the Slave device. This is a read-only field.
Hardware Rev.	The hardware revision of the device, from the GSD file.. This is a read-only field.
Class	The class of the Slave device. This is a read-only field.
Software Rev.	The software revision of the device, from the GSD file.. This is a read-only field.

3. Enter “Name”, “Description” and “Station” if desired.

- To add modules to the Slave, select the Modules tab and click Add. The Select New Module dialog box appears.

Note: To add the Slave to the configuration, you must configure at least one module.

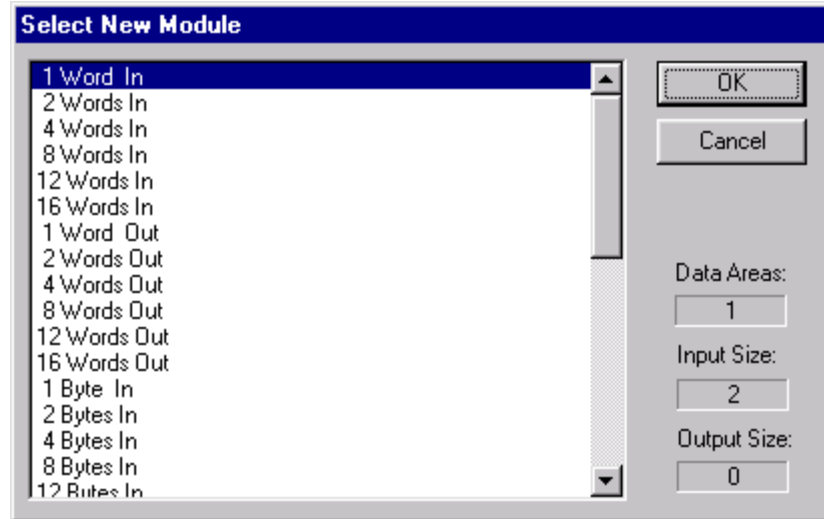

Note: The Select New Module list of items to choose from depends on the Slave. Each type of Slave is likely to have a different list of modules.

- Select a module and click OK. The module is added to the Modules list in the Slave Properties dialog box. Add additional modules as required for your system. The following figure shows the Modules tab after several modules have been added.

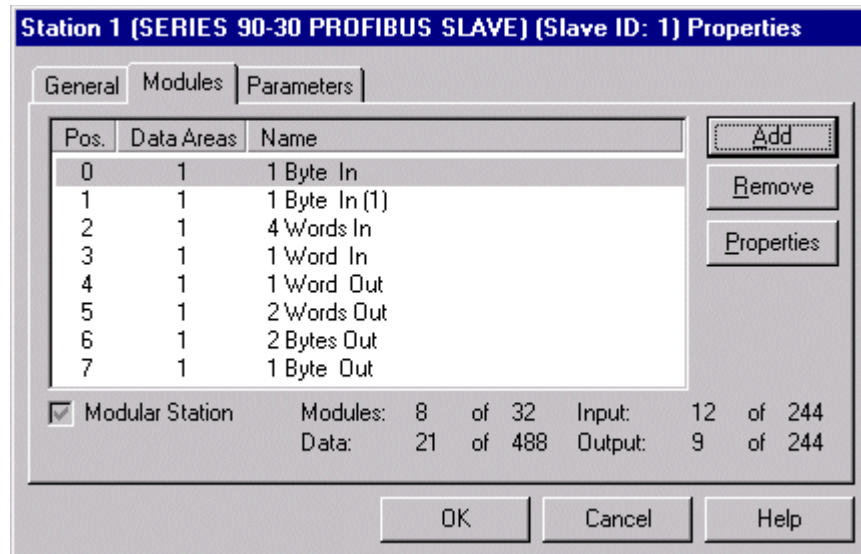

Note: To change the order (position) of a module, select it and click Properties. The module Properties dialog box opens. Enter the numerical value of the new position the module is to have. The position numbering starts at 0.

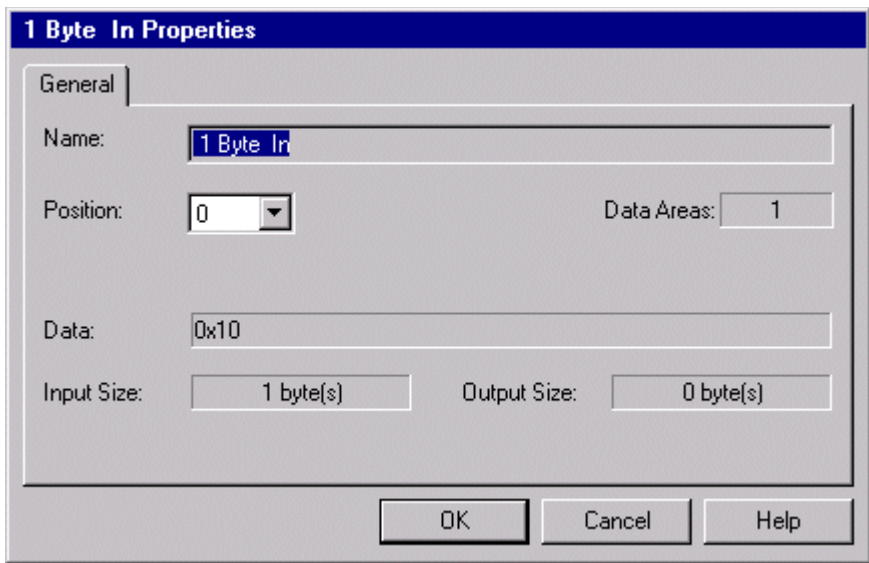

6. When you have finished adding modules, click OK. The modules appear under the Slave node in the Hardware Configuration.

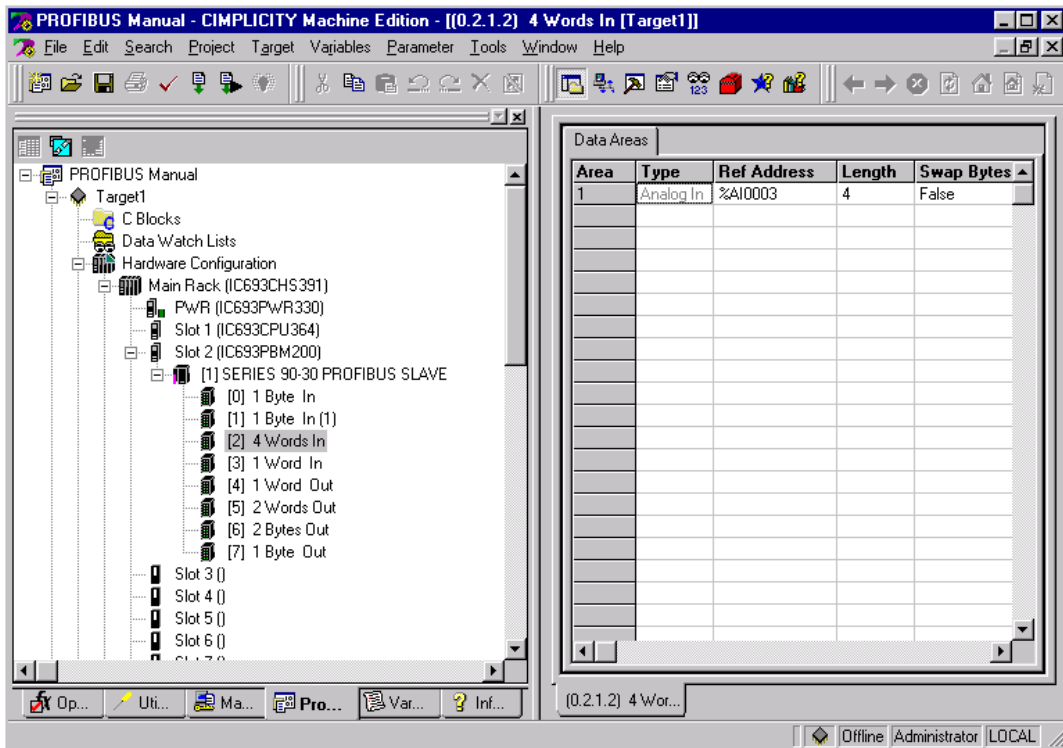

Note: To add, remove, or change the order of modules associated with an existing Slave, right click the Slave node in the Hardware Configuration and choose Configure. The Properties dialog box for the selected Slave opens. (See page 3-13.)

Configuring Module Data Areas

To configure module data areas, right click the module node in the Hardware Configuration, and choose Configure. The Parameter Editor window for the module appears.

The values for read-only parameters are supplied from the GSD text file that defines the Profibus module's characteristics. Most devices have one data area with inputs, outputs or both. Some devices have multiple data areas that are shown as additional rows.

Data Area Parameters

Area	This value is an index beginning at 1. Read-only.
Type	Specifies whether the data is input or output as well as type, digital or analog. Value can be Digital In, Analog In, Digital Out, or Analog Out.
Ref Address	Specifies the memory area that is used to map the data area. Regardless of the reference type used, input areas are considered as consumed and cannot overlap, while output areas are considered as produced and may overlap. Allowable Ranges: %AI, %AQ, %I, %Q, %G, %R, %T, %M. If the number of bytes is odd, analog memories are not allowed and selections are limited to: %I, %Q, %G, %M
Length	Specifies the length of the reference. Includes the entire data area by default. If set to 0, the data area is not mapped.
Allowable Ranges:	For discrete memories, the allowable range is [0, 8, 16, ..., X] For analog memories, the allowable range is [0, 1, 2, ..., X]
Swap Bytes	The swap bytes field is used to manipulate the byte order. Because Profibus devices often do not follow the standard, the ability to change byte ordering is provided. The analog areas travel in MSB and should be swapped if LSB is required. <ul style="list-style-type: none"> ■ If Type is Digital and the module has an odd number of bytes, Swap Bytes is set to False (no swapping) and read-only. ■ If Type is Digital and the module has an even number of bytes, default is set to False. Setting Swap Bytes to True causes the LSB and MSB to be swapped before the data is mapped into PLC memory. ■ If Type is Analog, default is set to False. Setting Swap Bytes to True causes the LSB and MSB to be swapped before the data is mapped into PLC memory.

There are four methods for obtaining status and diagnostic data:

- Observing and interpreting the LED indicators on the PROFIBUS modules
- Using the Slave Status Bit Array
- Observing the PLC Fault Table
- Utilizing Communications Request (COMMREQ) ladder logic instructions to instruct the PROFIBUS Master to gather diagnostic or status data and report it to the PLC CPU.

This chapter is divided into four sections:

- PROFIBUS Module LED Indicators, page 4-2
- Slave Status Bit Array, page 4-2
- PLC Fault Table Entries, page 4-3
- Communication Requests, page 4-4

PROFIBUS Module LED Indicators

Table 4-1. LED Patterns Before and During PROFIBUS Module Configuration

LED Pattern	Meaning
SYS off and COM blinking green	PROFIBUS Master not configured in PLC
The following blinking sequence repeats continually: SYS off, COM blinking green SYS off, COM blinking red SYS red, COM off	PROFIBUS Master configured in PLC but no slaves added
SYS red, COM green	PROFIBUS Master configured and slaves added. Note: This condition will continue until all the slaves are added and the configuration of each and every slave matches the master configuration.

Table 4-2. Patterns After PROFIBUS is Configured

LED Pattern	Meaning
Both LEDs solid green	Normal operation; no errors.
COM and SYS LEDs flash alternately	Module is in System Configuration mode (loading firmware)
SYS LED	
Red	One or more slaves is indicating a fault condition.
Amber	The module or CPU is in <i>Stop</i> or the module is in <i>Test</i> mode.
Green	The module is scanning in <i>Run</i> mode.
Flashing Green	System startup. Note: This LED flashes green for two seconds at system startup
COM LED	
Red, flashing at 1-second intervals	A network error has occurred.
Green	No network errors exist.

Slave Status Bit Array

The Slave Status bit array contains a bit for each slave. If communication with a slave has no errors, the bit corresponding to the slave (determined by its network address) is set. If the communication has errors or is not occurring for any reason, the bit is cleared. Also, the Master maintains its own status in the bit corresponding to its network address. The starting Address of the references for the Slave Status bit array is set in the PROFIBUS Master software configuration. For details, see “Parameters” in chapter 3.

PLC Fault Table Entries

Communications errors are displayed in the PLC fault table. For information on using fault tables, refer to the programming software's online help. For details on the effects of the different types of faults on PLC behavior, refer to the *Series 90-30 System Manual*, GFK-1411 or the *Series 90-30 Reference Manual*, GFK-0467.

Note: Slave communications status events (loss and re-establish) are reported to the PLC fault table by default. If the **Slave Status Fault Table Entries** parameter in the PROFIBUS Master software configuration is set to False, these events are not reported to the fault table. (For information on software configuration, see chapter 3.)

There are two I/O Faults that can be logged by the Profibus Master module

- Loss of Device - This fault is logged whenever there is a PROFIBUS fault detected on a configured slave, such as a timeout. That is, whenever the device bit in the Slave Status Table transitions from 1 to 0, this fault will be logged if there is not a LossOfNetwork.
- Addition of Device - This fault is logged whenever the device bit in the Slave Status Table transitions from 0 to 1, indicating that a device is active in the PROFIBUS scanlist.

The following figure shows the I/O fault table display.

The screenshot shows the 'Fault Table Viewer' interface. On the left, there are controls for 'Choose Fault Table' (PLC or I/O), 'Print Fault Tables', 'Fault Extra Data Format' (Byte, Word, ASCII), 'Sort Order' (Location, Description, Date/Time, None), and 'Clear I/O Fault Table'. The main display area shows two fault entries. The first entry is 'Add'n of Device' at location 0.2, CIRC No. 0, Ref. Address %I 00209, with a date/time of 02-11-2000 19:30:06. The second entry is 'Loss of Device' at the same location, CIRC No. 0, Ref. Address %I 00209, with a date/time of 02-11-2000 19:29:47. Each entry has a detailed view below it showing I/O Bus, Bus Address, Point Address, Group, Action, Category, and Fault Type.

Loc (rck.slt)	CIRC No.	Ref. Address	Fault Category	Fault Type	Date/Time
0.2	0	%I 00209	Add'n of Device	Undefined	02-11-2000 19:30:06
0.2	0	%I 00209	Loss of Device	-	02-11-2000 19:29:47

Communication Requests

The Communication Request function (COMMREQ) allows the program to communicate with a GE Fanuc intelligent module, such as a PROFIBUS Master module.

The COMMREQ function uses a *command block* that contains the data to be communicated to the other device, plus information related to the execution of the COMMREQ. The command block must be placed in the designated memory area using data move instructions, such as MOVE or BLKMOV (Block Move).

The CPU reports the result of the COMMREQ in the *status word*, which is a single location in PLC data memory. The status word address is specified in the command block. For a list of status codes reported in the status word, see “COMMREQ Status Word” on page 4-7.

For a list of COMMREQ tasks supported by the PROFIBUS Master module, see “PROFIBUS Master Module COMMREQ Reference” on page 4-8.

COMMREQ Ladder Instruction

This discussion provides an overview of the COMMREQ instruction. For details of the COMMREQ ladder instruction, refer to the online help provided with the programming software. The Communications Request begins when the COMMREQ Ladder Instruction is activated. The COMMREQ ladder instruction has four inputs and one output:

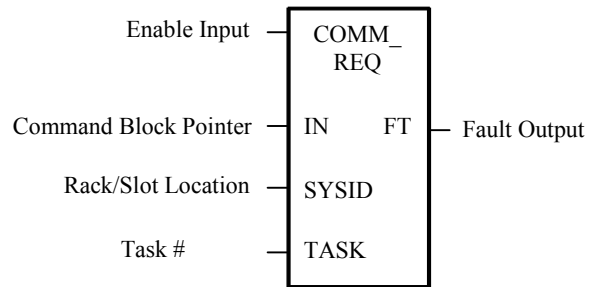

Figure 4-1. COMMREQ Ladder Instruction

Enable Input: Must be Logic 1 to enable the COMMREQ Instruction. It is recommended that the enabling logic be a contact from a transition (“one-shot”) coil.

IN: The memory location of the first word of the Command Block. It can be any valid address in word-type memory (%R, %AI, or %AQ). For example, %R00100 at IN would indicate that the starting address of the Command Block is %R00100.

SYSID: A hexadecimal value that gives the rack and slot location of the module that the COMMREQ is targeting. The high byte (first two digits of the hex number) contains the rack number, and the low byte contains the slot number. The table below shows some examples of SYSIDs:

SYSID Examples		
Rack	Slot	Hex Word Value
0	4	0004h
3	4	0304h
2	9	0209h

TASK: Must be 1.

FT Output: The function’s FT (fault) output can provide an output to optional logic that can verify successful completion of the Communications Request. The FT output can have these states:

FT Output Truth Table		
Enable Input Status	Does an Error Exist?	FT output
Active	No	Low
Active	Yes	High
Not active	No execution	Low

- The FT output is set High if:
 - The specified target address is not present (for example, specifying Rack 1 when the system only uses Rack 0).
 - The specified task number is not valid for the device.
 - Data length is set to 0.
- The FT output can either be connected to another device, such as a set coil, or can be left open.

Operation of the Communications Request

The figure below illustrates the flow of information between the PLC CPU and the PROFIBUS Master module:

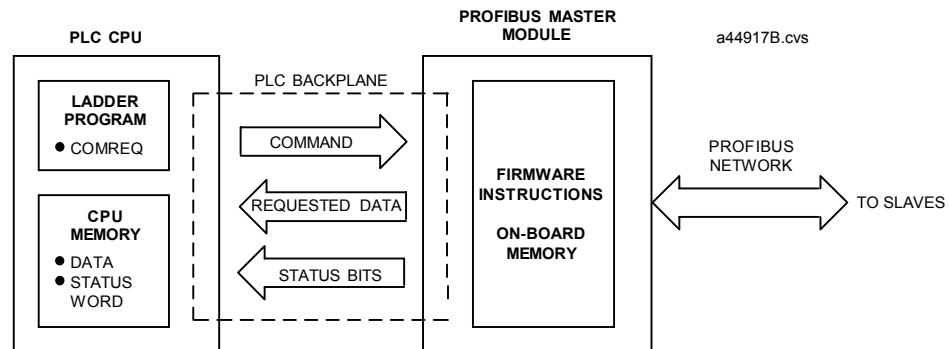

Figure 4-2. Operation of the PROFIBUS Communications Request

A Communications Request is initiated when a COMMREQ ladder instruction is activated during the PLC scan. At this time, a command from the PLC via the Communications Request is sent to the PROFIBUS Master module (PBM).

At the conclusion of every request, the PLC CPU reports the status of the request to the Status Word, which is a location in PLC memory that is designated by the Status Word Pointer in the Command Block.

In the figure above, the PBM is shown in the CPU rack and communications occur over the PLC backplane. If the PBM is located in an expansion or remote rack, the commands and data are sent over the CPU rack’s backplane, through the expansion or remote cable to the rack containing the PBM, and across that rack’s backplane to the PBM.

COMMREQ Programming Requirements and Recommendations

- COMMREQ instructions should be enabled by a contact from a transition coil.
- If using more than one COMMREQ in a ladder program, verify that a previous COMMREQ executed successfully before executing another one. This can be done by checking the Status Word and the FT (Fault) output.
- The FT output is held False if the Enable Input is not active. This means that if the COMMREQ is enabled by a transitional (one-shot) contact and a fault occurs, the FT output is High for only one PLC scan. To capture the fact that a fault occurred, you can program the fault output as a Set coil, which would not be automatically reset at the end of a scan. Additional logic would then be needed to reset the fault output coil after the fault is acknowledged and before the next execution of the COMMREQ.
- Programming a device, such as a Set Coil, on the FT output of the COMMREQ is optional; this output may be left open if desired.
- It is necessary to initialize the data in the Command Block before executing the COMMREQ instruction. Since the normal PLC sweep order is from top to bottom, initializing the Command Block in an earlier rung (or rungs) than the rung that contains the COMMREQ will satisfy this requirement.
- If you use MOVE instructions to load values into Command Block registers, use a Word-type MOVE to load a hexadecimal number, and an Integer-type MOVE to load a decimal number.

Error Detection and Handling

As shown in “COMMREQ Status Word”, a value of 1 is returned to the Status Word if communications proceed normally, but if any error condition is detected, a value greater than 1 is returned. If you require error detection in your ladder program, you can use a Greater Than (GT) compare instruction to determine if the value in the Status Word is negative (less than zero). If an error occurs, the GT instruction’s output (Q) will go high. A coil driven by the output can be used to enable fault handling or error reporting logic.

The FT output of the COMMREQ, described on page 4-5, goes high for certain faults and can be used for fault detection also. Additionally, the first Status Word can be monitored by error message logic for display on an Operator Interface device, in which case, Status Word codes would correspond to appropriate error messages that would display on the operator screen.

To dynamically check the Status Word, write a non-significant positive number (0 or 99 are typically used) into the Status Word each time before its associated COMMREQ is executed. If the instruction executes successfully, the CPU will write the number 1 there. This method lets you know that if the number 1 is present, the last COMMREQ definitely executed successfully, and that the 1 was not just left over from a previous execution.

When multiple COMMREQs are used, it is recommended that each be verified for successful communications before the next is enabled. Monitoring the Status Word is one way to accomplish this.

Corrective Actions for COMMREQ Errors

The type of corrective action to take depends upon the application. If an error occurs during the startup or debugging stage of ladder development, you should verify the COMMREQ parameters. The same is true if an error occurs right after a program is modified. But, if an error occurs in a proven application that has been running successfully, the problem is more likely to be hardware-related. The PLC fault tables should be checked for possible additional information when troubleshooting Status Word errors.

COMMREQ Status Word

The following table defines the format of the Status Block used during the COMM_REQ handshake.

Table 4-3. Status Word Format

Word	Name	Description
Word 1	State (see table 4-4)	The state of the current COMM_REQ request
Word 2	LostCommand	Command code of the last command lost when the CRL bit is set in Flags.
Word 3	ErrorCode	Not Used
Word 4	AdditionalCode	Additional code for error reporting

Table 4-4. Status Word State Codes

Value (hex)	Description
0x00	Module has not yet processed the COMM_REQ
0x01	Command Complete Note: This status does not necessarily mean success. Some commands have reply data that must also be checked.
0x02	Command Terminated – module busy
0x03	Command Terminated – invalid command
0x04	Command Terminated – invalid command data
0x05	Command Terminated – not enough data
0x06	Command Terminated – command collision An identical command, which has already reported completion, is currently being processed and has not replied yet.
0x07	Command Terminated – not enough memory in reply area The command did not specify sufficient PLC memory for the reply. Command will be ignored.
0x08	Command Terminated – command-specific error. See AdditionalCode in the Status Block for more information.

PROFIBUS Master Module COMMREQ Reference

The PROFIBUS Master module supports the following COMMREQ tasks and responses.

Table 4-5. PROFIBUS Master COMMREQs

Task	Name	Description	Page No.
1	Get Device Status	Retrieves detailed status information for the specified node.	4-9
2	Get Master Status	Retrieves detailed status information for the Master.	4-12
4	Get Slave Diagnostics	Retrieves diagnostics for a specified Slave.	4-15
5	Read Module Header	Retrieves module header information.	4-17
6	Clear Counters	Clears counters in ReadModuleHeader	4-20

Memory Types

The following table lists the memory types that can be used by the PROFIBUS Master for the Status Block and Reply Data areas.

Table 4-6. COMMREQ Status Word Memory Type Codes

Memory Type Abbreviation	Memory Type	Decimal code to enter
%I	Discrete input table (BYTE mode)	16
%Q	Discrete output table (BYTE mode)	18
%R	Register memory	8
%AI	Analog input table	10
%AQ	Analog output table	12
%T	Discrete temporary memory (BYTE)	20
%M	Discrete internal memory (BYTE)	22

Get Device Status (1)

The Get Device Status Command retrieves detailed status information for the specified device

Get Device Status Command Block – Basic Example

The following command block accomplishes the following:

Get Device Status for Device 1.
 Return the COMMREQ Status Words to %R10—%R13.
 Return the Device Status to %R251-%R259.

Word	Dec (Hex)	Definition
Word 1	00005 (0005)	Length of command Data Block
Word 2	00000 (0000)	Always 0 (no-wait mode request)
Word 3	00008 (0008)	Memory type of COMMREQ status word (%R)
Word 4	00009 (0009)	COMMREQ status word address minus 1 (%R10)
Word 5	00000 (0000)	Reserved
Word 6	00000 (0000)	Reserved
Word 7	00001 (0001)	Get Device Status command number
Word 8	00008 (0008)	Memory type to write response (%R)
Word 9	00250 (00FA)	Starting Address to write response (response written to %R251)
Word 10	00009 (0009)	Maximum size of response area
Word 11	00001 (0001)	Slave number (0—125)

(Word 7) Command Code: Word 7 specifies the Command code for the COMMREQ to be executed . Get Device Status = 1

(Word 8) Local PLC - Memory Type: Words 8—9 specify the location in the PLC where the response will be written. Valid values for Word 8 are listed below

Type	Value (Decimal)	Description
%R	8	Register memory (word mode)
%AI	10	Analog input memory (word mode)
%AQ	12	Analog output memory (word mode)
%I	16	Discrete input memory (byte mode)
%Q	18	Discrete output memory (byte mode)
%T	20	Discrete temporary memory (byte mode)
%M	22	Discrete momentary internal memory (byte mode)

(Word 9) Response Memory Starting Address: Word 9 determines the starting address in the PLC in which the response is to be written. The value entered is the offset (0-based) from the beginning of PLC memory for the memory type and mode specified in Word 8. This offset will be either in bits, bytes, or words depending on the mode specified (for example, if Word 8=16 and Word 9=2, then the starting address will be %I9). Valid ranges of values depend on the PLC’s memory ranges

(Word 10) Response Memory Size: Word 10 specifies the size of the memory block for the response. The COMMREQ has built-in future expansion space in the response field. The Response

Memory Size (including the future expansion space) is 9 words. In the current version of firmware 1.12, the response size is 2 words and only 2 words are written to memory. The user is responsible for assuring that this area is large enough to contain the requested data without overwriting other application data. The user is responsible for assuring that this area is large enough to contain the requested data without overwriting other application data. It is recommended that the future expansion space be allocated initially, to avoid problems if future firmware upgrades use more than 2 words for the response.

(Word 11) Slave Number: Word 11 specifies the address of the device the COMMREQ is retrieving device status from. If the address of the master, or a slave which is not, on the bus is entered a COMMREQ Status Word response of 4 will be returned.

Get Device Status Reply Data Format – Response written to location specified by Words 8 & 9

Word	Name	Description
Word 1	CommandCode	Echo of Command code that this data block is replying to (0x0001).
Word 2	StatusCode/Extended Status Code	Code indicating the status of the client connection to the device. See status code tables below.
Word 3—9	Reserved for future use.	Word 10 of the Get Device Status command block should specify a minimum of 9 words to accommodate possible future use of this space.

Get Device Status Codes – Low Byte of Word 2

Status	Meaning
00h	Slave Ok.
01h	Failure while trying to configure slave. Check table below for extended Status Code.
02h	Slave real ID does not match slave's configured ID.
03h	Frame delivery problem while updating slave data. Check following tables for Extended Status Codes.
04h	Frame delivery problem while reading slave diagnostics.
05h	Error in diagnostic status byte #1 during configure.
06h	Error in diagnostic status byte #2 during configure.
07h	Error in diagnostic status byte #1 during diagnostic read.
08h	Error in diagnostic status byte #2 during diagnostic read.
09h	Station address from diagnostic read does not match.
0Ah	Timeout waiting for IO update.
0Bh	Warning: Slave watchdog is not enabled.

Note: If the Status code is 01 or 03, the upper byte must be interpreted using the following “Extended Status” tables.

Get Device Status Code 01h Extended Status Codes – High Byte of Word 2

Status	Meaning
00h	No Extended codes available.
01h	No response or NAK (not acknowledged) after sending the first diagnostic status request to the slave.
02h	No response or NAK after sending parameter data to the slave.
03h	No response or NAK after sending configuration check data to the slave.
04h	No response or NAK after sending the second diagnostic status request to the slave.
05h	Invalid response after sending the first diagnostic status request to the slave.
06h	Invalid response after sending parameter data to the slave.
07h	Invalid response after sending configuration check data to the slave.
08h	Response to configuration check packet was non-zero length(slave should never return anything).
09h	Invalid response after sending the second diagnostic status request to the slave.

Get Device Status Code 03h Extended Status Codes – High Byte of Word 2

Status	Meaning
0Ah	Error in data update during configuration.
0Bh	No response or NAK when updating data while online.

Get Master Status (2)

The Get Master Status Command provides detailed status information about the Master module.

Get Master Status Command Block – Basic Example

The following command block accomplishes the following:

Get Master Status.

Return the COMMREQ Status Word to %R10—%R13.

Return the Device Status to %R251—%R259.

Word	Dec (Hex)	Definition
Word 1	00004 (0004)	Length of command Data Block
Word 2	00000 (0000)	Always 0 (no-wait mode request)
Word 3	00008 (0008)	Memory type of COMMREQ status word (%R)
Word 4	00009 (0009)	COMMREQ status word address minus 1 (%R10)*
Word 5	00000 (0000)	Reserved
Word 6	00000 (0000)	Reserved
Word 7	00002 (0002)	Get Master Status command number
Word 8	00008 (0008)	Memory type to write response (%R)
Word 9	00250 (00FA)	Starting Address to write response (response written to %R251)
Word 10	00009 (0009)	Maximum size of response area

(Word 7) Command Code: Word 7 specifies the Command code for the COMMREQ to be executed . Get Master Status = 2

(Word 8) Local PLC - Memory Type: Words 8—9 specify the location in the PLC where the response will be written. Valid values for Word 8 are listed below.

Type	Value (Decimal)	Description
%R	8	Register memory (word mode)
%AI	10	Analog input memory (word mode)
%AQ	12	Analog output memory (word mode)
%I	16	Discrete input memory (byte mode)
%Q	18	Discrete output memory (byte mode)
%T	20	Discrete temporary memory (byte mode)
%M	22	Discrete momentary internal memory (byte mode)

(Word 9) Local PLC - Memory Starting Address: Word 9 determines the starting address in the local PLC in which the response is to be written. The value entered is the offset (0-based) from the beginning of PLC memory for the memory type and mode specified in Word 8. This offset will be either in bits, bytes, or words depending on the mode specified (for example, if Word 8=16 and

Word 9=2, then the starting address will be %I9). Valid ranges of values depend on the PLC's memory ranges.

(Word 10) Response Memory Size: Words 10 specifies the size of the memory block for the response. The COMMREQ has built-in future expansion space in the response field. The Response Memory Size (including the future expansion space) is 9 words. In the current version of firmware 1.12, the response size is 2 words and only 2 words are written to memory. The user is responsible for assuring that this area is large enough to contain the requested data without overwriting other application data. It is recommended that the future expansion space be allocated initially, to avoid problems if future firmware upgrades use more than 2 words for the response.

Get Master Status Reply Data Format – Response written to location specified by Words 8 & 9

Word	Name	Description
Word 1	CommandCode	Echo of Command code that this data block is replying to. (0x0002)
Word 2	StatusCode	Code indicating the status of the Master module. See tables below for meaning of the code
Words 3—9	Reserved for future use	Word 10 of the Get Master Status command block should specify a minimum of 9 words to accommodate possible future use of this space.

Get Master Status Network Parameter Errors

The following status errors may occur when you set the network parameters. Values are in hexadecimal.

Status	Meaning
00h	No error
01h	Bad command
02h	Bad baud rate
03h	Bad station address
04h	Bad high station address
05h	Bad token rotation time
06h	Bad slot time
07h	Bad idle time 1
08h	Bad idle time 2
09h	Bad ready time
0Ah	Bad quiet time
0Bh	Bad gap update time
0Ch	Bad token retry
0Dh	Bad message retry
0Eh	Bad token error limit
0Fh	Bad response error limit
10h	Baud detect error

Get Master Status Configuration Errors

The following errors may occur when you configure the Master through the init file generated by the configuration tool.

Status	Meaning
20h	Bad check pattern
21h	Binary configuration too short
22h	Binary configuration too long
23h	Bad checksum
24h	Invalid CPU header
25h	Invalid slave Rx type
26h	Rx overflow
27h	Tx overflow
28h	Master extended allocation error
29h	Invalid Configuration Fileformat
2Ah	Parse Configuration file error
2Bh	Failed to go online

Get Master Status Flash Programming Errors

The following errors may occur when you program flash memory.

Status	Meaning
30h	No configuration
31h	Bad ID
32h	Erase error
33h	Programming error
34h	Verification error
35h	Timeout waiting for IO update
36h	Warning: Slave watchdog is not enabled

Get Master Status Fatal Errors

The following are fatal errors. The module must be reset to resume operation.

Status	Meaning
80h	Internal error
81h	Out of Data Structure Buffers
82h	Host Watchdog byte
83h	Heap allocation failure
84h	Shared heap allocation failure

Get Device Diagnostics (4)

The Get Device Diagnostic command retrieves detailed status information for the specified device.

Get Device Diagnostics Command Block – Basic Example

The following command block accomplishes the following:

Get Device Diagnostics for Device 1 (a PBS201Release 1).
 Return the COMMREQ Status Word to %R10—%R13.
 Return the Device Status to %R251—%R259.

Word	Dec (Hex)	Definition
Word 1	00005 (0005)	Length of command Data Block
Word 2	00000 (0000)	Always 0 (no-wait mode request)
Word 3	00008 (0008)	Memory type of COMMREQ status word (%R)
Word 4	00009 (0009)	COMMREQ status word address minus 1 (%R10)
Word 5	00000 (0000)	Reserved
Word 6	00000 (0000)	Reserved
Word 7	00004 (0004)	Get Device Diagnostics command number
Word 8	00008 (0008)	Memory type to write response (%R)
Word 9	00250 (00FA)	Starting Address to write response(response written to %R251)
Word 10	00009 (0009)	Maximum size of response area. If this value is not large enough to fit all the diagnostic data, a 7 is returned in the COMMREQ Status Word. The user is responsible for allocating enough space to contain the requested data without overwriting other application data.
Word 11	00001 (0001)	Slave number (0—125)

(Word 7) Command Code: Word 7 specifies the Command code for the COMMREQ to be executed. Get Device Diagnostics = 4

(Word 8) Local PLC - Memory Type: Words 8—9 specify the location in the PLC where the response will be written. Valid values for Word 8 are listed below.

Type	Value (Decimal)	Description
%R	8	Register memory (word mode)
%AI	10	Analog input memory (word mode)
%AQ	12	Analog output memory (word mode)
%I	16	Discrete input memory (byte mode)
%Q	18	Discrete output memory (byte mode)
%T	20	Discrete temporary memory (byte mode)
%M	22	Discrete momentary internal memory (byte mode)

(Word 9) Local PLC - Memory Starting Address: Word 9 determines the starting address in the local PLC in which the response is to be written. The value entered is the offset (0-based) from the beginning of PLC memory for the memory type and mode specified in Word 8. This offset will be either in bits, bytes, or words depending on the mode specified (for example, if Word 8=16 and Word 9=2, the starting address will be %I9). Valid ranges of values depend on the PLC's memory ranges.

(Word 10) Response Memory Size: Word 10 specifies the size of the memory block for the response. If the Diagnostic data does not fit in this memory block, a value of 7 is returned in the COMMREQ Status Word. The user is responsible for assuring that this area is large enough to contain the requested data without overwriting other application data

Note: A GE Fanuc 90-30 PROFIBUS Slave (PBS201) returns 13 bytes (7 words) of data. Word 10 needs to be 9 or larger.

(Word 11) Slave Number: Word 11 specifies the address of the slave to which COMMREQ is directed. If the address of the master or a slave that is not on the bus is entered ,a Status response of 4 is returned.

Get Device Diagnostics Reply Data Format – Response written to location specified by Words 8 & 9

Word	Name	Type	Description
Word 1	CommandCode	UINT2	Command code that this data block is replying to. (0x0004)
Word 2	Size of Diagnostics	UINT2	The size of the data. If it is greater than the memory area specified in word 10 of the Get Device Diagnostics command block, the COMMREQ will fail, returning a 7 in the COMMREQ Status Word (page 4-7).
Word 3	Diagnostics	BYTE	The diagnostics of the given slave.

Read Module Header (5)

The Read Module Header command retrieves Network Diagnostic Information and statistics from the Device

Read Module Header Command Block – Basic Example

The following command block accomplishes the following:

Get Module Header Data.

Return the COMMREQ Status Word to %R10—%R13.

Return the Device Status to %R251—%R283.

Word	Dec (Hex)	Definition
Word 1	00004 (0004)	Length of command Data Block
Word 2	00000 (0000)	Always 0 (no-wait mode request)
Word 3	00008 (0008)	Memory type of COMMREQ status word (%R)
Word 4	00009 (0009)	COMMREQ status word address minus 1 (%R10)
Word 5	00000 (0000)	Reserved
Word 6	00000 (0000)	Reserved
Word 7	00005 (0005)	Read Module Header command number
Word 8	00008 (0008)	Memory type to write response (%R)
Word 9	00250 (00FA)	Starting Address to write response(response written to %R251)
Word 10	000033 (0021)	Size of response area, 33 for master

(Word 7) Command Code: Word 7 specifies the Command code for the COMMREQ to be executed . Read Module Header = 5

(Word 8) Local PLC - Memory Type: Words 8—9 specify the location in the PLC where the response will be written. Valid values for Word 8 are listed below:

Type	Value (Decimal)	Description
%R	8	Register memory (word mode)
%AI	10	Analog input memory (word mode)
%AQ	12	Analog output memory (word mode)
%I	16	Discrete input memory (byte mode)
%Q	18	Discrete output memory (byte mode)
%T	20	Discrete temporary memory (byte mode)
%M	22	Discrete momentary internal memory (byte mode)

(Word 9) Local PLC - Memory Starting Address: Word 9 determines the starting address in the local PLC in which the response is to be written. The value entered is the offset (0-based) from the beginning of PLC memory for the memory type and mode specified in Word 8. This offset will be either in bits, bytes, or words depending on the mode specified (for example, if Word 8=16 and Word 9=2, the starting address will be %I9). Valid ranges of values depend on the PLC's memory ranges.

(Word 10) Response Memory Size: Word 10 specifies the size of the memory block for the response. The Response Memory Size is 33 words. If the Response Memory Size is set smaller than 33, the COMMREQ will fail with a 7 in the COMMREQ Status Word. The user is responsible for assuring that this area is large enough to contain the requested data without overwriting other application data

ReadModuleHeader Reply Data Format for Master

Word	Name	Description
Word 1	Command Code	Echo of Command Code that this data block is replying to (0x0005)
Word 2	ModuleType	A value of 2 indicates the module is a Master. Contains 1 if the module is a Slave.
Word 3	PfbStatus	PROFIBUS Status register, also can be read using the Get Master Status COMMREQ. For definitions, see page 4-13.
Word 4	ModuleVersion	Module firmware version 0112h = 1.12
Word 5	ErrLanOffline	Counter. LAN went offline due to errors.
Word 6	DiagConf	Total confirmations
Word 7	DiagInd	Total indications
Word 8	ErrNotOk	Total not OK confirmations and indications
Word 9,10	DiagTokHldTime	Instantaneous token hold time
Word 11,12	DiagMinTokHldTime	Minimum token hold time
Word 13	DiagMasterUpdate	Master I/O update cycles completed
Word 14	ErrMasErr	Master->DP slave errors
Word 15	ErrMasReConfig	Master->DP went offline and had to be reconfigured
Word 16,17	DiagMasScanTime	Master scan time(μ s)
Word 18,19	DiagMasMaxScanTime	Maximum master scan time(μ s)
Word 20	ErrInvReqLen	Invalid request length error counter
Word 21	ErrFifo	FIFO overflow error counter
Word 22	ErrRxOverun	Receive overrun error counter
Word 23	ErrDbtTok	Double token error counter
Word 24	ErrRespErr	Response error counter
Word 25	ErrSynErr	General network error counter
Word 26	ErrNetTout	Network timeout error counter
Word 27	ErrHsa	Station higher than HighestAddressedStation was heard counter
Word 28	ErrStn	Duplicate station detected counter
Word 29	ErrPasTok	Unable to pass token counter
Word 30	ErrLasBad	Active station list is invalid
Word 31	ErrInternal	Internal errors
Word 32	ErrArg	Argument errors
Word 33	ErrEventOverun	A new event occurred before the last one was cleared

Note: If the Name starts with Err, the value stops at the maximum. If the Name starts with Diag the count rolls over to zero.

Clear Counters (6)

The Clear Counters Command clears the counters in the PROFIBUS Master module to zero.

Clear Counters Command Block – Basic Example

The Clear Counters Command sets the counters to zero.

In the following command block, Status is returned in %R251—%R252 (words 8 and 9).

Word	Dec (Hex)	Definition
Word 1	00004 (0004)	Length of command Data Block
Word 2	00000 (0000)	Always 0 (no-wait mode request)
Word 3	00008 (0008)	Memory type of COMMREQ status word (%R)
Word 4	00009 (0009)	COMMREQ status word address minus 1 (%R10)
Word 5	00000 (0000)	Reserved
Word 6	00000 (0000)	Reserved
Word 7	00006 (0006)	Clear Counters command number
Word 8	00008 (0008)	Memory type to write response (%R)
Word 9	00250 (00FA)	Starting Address to write response(response written to %R251)
Word 10	00002 (0002)	Maximum size of response area

(Word 7) Command Code: Word 7 specifies the Command code for the COMMREQ to be executed. Clear Counters = 6

(Word 8) Local PLC - Memory Type: Words 8—9 specify the location in the PLC where the response will be written. Valid values for Word 8 are listed below

Type	Value (Decimal)	Description
%R	8	Register memory (word mode)
%AI	10	Analog input memory (word mode)
%AQ	12	Analog output memory (word mode)
%I	16	Discrete input memory (byte mode)
%Q	18	Discrete output memory (byte mode)
%T	20	Discrete temporary memory (byte mode)
%M	22	Discrete momentary internal memory (byte mode)

(Word 9) Local PLC - Memory Starting Address: Word 9 determines the starting address in the local PLC in which the response is to be written. The value entered is the offset (0-based) from the beginning of PLC memory for the memory type and mode specified in Word 8. This offset will be either in bits, bytes, or words depending on the mode specified (for example, if Word 8=16 and Word 9=2, then the starting address will be %I9). Valid ranges of values depend on the PLC's memory ranges.

(Word 10) Response Memory Size: Words 10 specifies the size of the memory block for the response. The Response Memory Size is 2 words. If the Response Memory Size (word 10 in the Clear Counters command block) is set greater than 2, the COMMREQ will succeed. The unneeded memory locations are not written.

Clear Counters Reply Data Format

Word	Name	Description
Word 1	CommandCode	Echo of Command code that this data block is replying to. (0x0006)
Word 2	StatusCode	Reports 1 for success and 0 for failure.

C

- Cable specifications, 2-4
- Cable types, 2-4
- Clear Counters (6), 4-20
- COMMREQs
 - Clear Counters (6), 4-20
 - Get Device Diagnostics (4), 4-15
 - Get Device Status (1), 4-9
 - Get Master Status (2), 4-12
 - memory types, 4-8
 - PROFIBUS Master, 4-8
 - Read Module Header (5), 4-17
- COMMREQs, general information, 4-4
 - error detection and handling, 4-6
 - ladder instruction, 4-4
 - operation, 4-5
 - programming recommendations, 4-6
 - status word, 4-7
- Configuration, 3-1

F

- Fault table entries, 4-3
- Features, 1-3

G

- Get Device Diagnostics, 4-15
- Get Device Status, 4-9
- Get Master Status, 4-12

I

- Installation procedures, 2-1
 - connecting the Master to the PROFIBUS network, 2-2
 - installing bus termination, 2-5
 - installing the module in the rack, 2-2
 - reviewing system power requirements, 2-1

N

- NAK (not acknowledged), 4-11

O

- Overview, 1-1

P

- Pin-out
 - PROFIBUS bus plug connector, 1-6
 - PROFIBUS connector, 2-2
- PLC fault table entries, 4-3

- Power consumption, 1-3
- Power supplies, 2-1
- PROFIBUS

- baud rate, 2-6
- bus communication, 1-4
- cable types, 2-4
- network connectors, 1-6
- network overview, 1-4
- network topology, 1-5
- references, 1-1

R

- Read Module Header, 4-17
- Redundant masters, 3-1
- Removing the module from the rack, 2-6
- Reviewing system power requirements, 2-1

S

- Selecting the proper line type, 2-3
- Specifications
 - cable, 2-4
 - CPU firmware, 1-3
 - environment, 1-3
 - master module, 1-3
 - mounting location, 1-3
 - power consumption, 1-3
 - status information available, 1-3
- Status and diagnostic methods, 4-1
- Status Word codes, 4-7