



Microwave Linear Intrusion Sensors

FMW-3/1

FMW-3/2

FMW-3(200m,300m)

User manual

Document Part Number 4372-43071246-004

Conformance certificate

№ POCC RU.OC03.B01413

CERTIFICATE OF CONFORMITY

2013

CONTENTS

1. Introduction	3
2. Purpose	3
3. Specifications	3
4. Sensor Components	5
5. Sensor Structure & Operation	5
5.1. Sensor Principle of Operation	5
5.2. Adjustment, Control and Indication Parts	6
5.3. Sensor Operation	6
6. Sensor Construction	7
6.1. Rx-3, Rx 3/1, Rx 3/2	7
6.2. Tx Construction (Tx-3, Tx-3/1, Tx-3/2)	7
6.3. MK (mounting kit)	7
7. Safety Measures	10
8. Mounting Procedure	10
8.1. Requirements for the preparation of the sector and the arrangement of Rx and Tx	10
8.2. Sensor Mounting	10
8.3. Sensor Connection	12
9. Sensor preparation for the Operation & Adjustment	15
9.1. Sensor Preparation for its Operation	15
9.2. Tx and Rx adjustment	15
9.3. Rx threshold	15
10. Sensor operation with the deflector	16
11. Check of Technical State	16
11.1. Check of Sensor Operation	16
11.2. Servicing	17
12. Troubleshooting Guide	17
13. Storage	18
14. Transportation	18
Certificate	19

1. INTRODUCTION

The present user manual contains information about the operation of the microwave linear intrusion sensors “FMW – 3”, “FMW – 3/1”, “FMW - 3/2” (below the sensor). In this document there is information required for the correct operation (use, transportation, storage and maintenance) of the sensors.

The following abbreviations are used in the present document:

Tx - transmitter;
 Rx - receiver;
 MK - mounting kit;
 SU - supply unit;
 JB - junction box.

2. PURPOSE

2.1. The purpose of the sensor is to protect regular, open sectors and to detect an intruder crossing at his full height or bent (crawling) through this sector.

2.2. The sensor is intended for continuous round-the-clock outdoor operation at an ambient temperature $-40^{\circ}\text{C} \dots +65^{\circ}\text{C}$ and relative humidity up to 98% at the temperature $+35^{\circ}\text{C}$.

3. SPECIFICATIONS

3.1. The recommended length of a sector for the modifications:

“FMW-3” sensors -10...300 m

“FMW-3/1” sensors -10...100 m

“FMW-3/2” sensors -5...50 m.

3.2. The configuration and the detection zone’s dimensions are given in fig.3.1. and table 3.1.

The detection zone is a volumetric part that being the very specialty in the kind of detection, and any movement within this sector will generate an alarm.

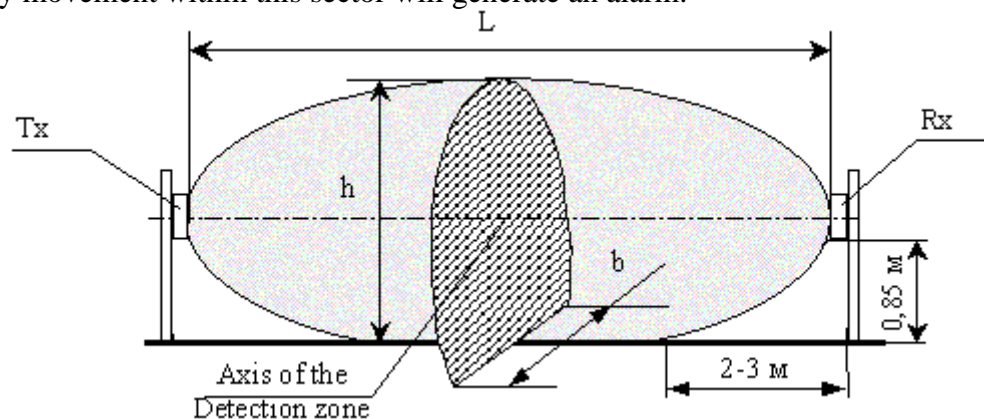

Fig.3.1.

L- Length of a sector

h- Height of the detection zone

b- Width of the detection zone

In fig.3.1 and table 3.1 the height (h) and the width (b) of the detection zone are given for the middle of the sector. Moving towards the receiver or transmitter these dimensions decrease evenly, given the geometry of positioning the receiver and transmitter.

Table 3.1.

Dimensions, maximum, m	Length of a sector L, m						
	5	15	35	50	100	200	300
h				1,4	1,6	1,7	1,8
b	0,75	1	1,5	2	3	4	5

3.3. The minimum distance recommended from the axis of the detection zone from building walls and other nonmoving objects should be as follows:

200...300m - 2,5 m minimum;

100...200m - 2,0 m minimum;

35...100m - 1,5 m minimum;

5...50 m - 1,0 m minimum.

3.4. The sensor generates an alarm when:

- An intruder crosses a detection zone (perpendicularly to the axis) at a speed of 0,1...10 m/sec at his full height or bent with the minimum detection probability 0,98;

- RC signal is given on Tx;

- influence of electromagnetic field on Rx for its masking (not visible). An alarm can be absent but the sensor is operable.

An alarm is generated by breaking the contacts of an individual point relay for the time 3 sec minimum. This signal is sent from Rx by yellow and pink colored wires marked "NC"; "NC" (normally closed).

Note. At a distance of 2-3m from the supports on which Tx and Rx are installed, the probability of the intruder's detection who is bent (crawls through) is 98%.

3.5. The sensor generates a fault signal in the case:

- The absence of the signal from Tx;

- The absence of power supply or when the voltage drops below 9 V;

- Failure of Rx or Tx.

A fault signal is generated constantly (latching) till the same is rectified and is indicated by break in the contacts of an individual point opt electronic relay indicated by yellow and pink colored wires marked "NC", "NC".

3.6. The dimensions of an individual point opt electronic relay are: the maximum switching current is 0,1 A; the maximum voltage is 50 V; the maximum resistance is 130 Ohm in the closed status (with the elements of storm protection).

3.7. Removal/opening of the back inspection cover of the Rx unit generates a tamper alarm. The contacts of the tamper circuit are broken and this is reflected at the Rx unit through the green and grey colored wires marked "TAMPER", "TAMPER". Contact dimensions of this tamper circuit are: current up to 0,2A at voltage up to 80 VDC.

3.8. The sensors power supply is: 9...30 VDC with maximum pulsation of 0,02 V maximum. The maximum current consumption is 35 mA at 24 VDC.

3.9. The sensor operation can be tested by applying 5...30 VDC signal at the RC on the Tx unit. The RC is marked as "RC" input of the transmitter. The duration of this test signal is 1...3 sec.

3.10. The sensor doesn't generate an alarm in the case:

- rain, snow, fog;

- solar radiation;

- the influence of wind at a speed of 30 m/sec maximum;

- moving of the objects in the DZ of 3 m from Rx or Tx with the linear dimensions of 0, 2 m maximum (birds or small animals);

- irregularities on the sector up to $\pm 0, 3$ m;

- snow without additional adjustment up to 0, 5 m;

- grass up to 0, 3 m;

- influence of the radiated emission of ultra short waves of the range 150-175 MHz up to 40 Vat on the distance 6m maximum.

3.11. The sensor is immune to EMI (voltage impulses in supply circuits, breaks of mains supply, electrostatic discharges, and electromagnetic fields).

3.12. Input circuits of Tx and Rx are protected from electric pickup (electric storm too).

3.13. The sensor mean lifetime is 8 years.

3.14. Maximum dimensions of the units without a mounting kit are:

"FMW - 3" - 213*213*70 (Rx-3), (Tx-3)

"FMW - 3/1" - 211*135*75 (Rx-3/1), (Tx-3/1)

"FMW - 3/2" - 120*110*60 (Rx-3/2), (Tx-3/2).

3.15. Maximum weight of the units with a mounting kit, kg:

"FMW-3" - 1,2 (Rx-3), 1,2 (Tx-3)

"FMW - 3/1" - 1,0 (Rx-3/1), 1,0 (Tx-3/1)

"FMW - 3/2" - 0,4 (Rx-3/2), 0,4 (Tx-3/2).

4. SENSOR COMPONENTS

The sensor delivery kit is:

1. Receiver – 1 item

2. Transmitter - 1 item

3. Mounting kit FMW (MK-FMW) including:

- Bracket – 2 items

- Buckle – 4 items

4. Kit of tools and accessories including:

- Alarm cable

- Key S8*10.

5. User manual

6. Package

7. Supply unit “PSU24-0, 7” and junction box “Barrier-JB” are delivered on the customer demand.

Mounting kit for Tx, Rx fastening on the wall is delivered on the customer demand.

5. SENSOR STRUCTURE & OPERATION

5.1. Sensor Principle of Operation

5.1.1. The sensor is a bistatic microwave device.

The principle of the sensor operation is to generate an electromagnetic field in the space between a transmitter and a receiver. This field provides a volumetric detection zone in the form of a long ellipsoid of rotation (see fig.3.1.). An intruder crossing a detection zone causes changes of the field. All changes of this field are recorded. There is the detection zone configuration in fig.3.1, there are given in table its crosscuts dimensions for three performances of the sensor dependency on the length of a sector with the height 0,85m of Rx & Tx mounting.

5.1.2. An intruder crossing a detection zone causes changes of the electromagnetic field between Rx and Tx and of the Rx signal characteristics. The input circuit passes through the amplifier and proceeds on the input of the microcontroller. The filtered signal is compared with the value thresholds according to the algorithm. If the signal value oversteps the thresholds, Rx will generate an alarm breaking output contact of the relay. Quantitative change of the signal depends on the height, weight of a person, place of sector crossing, its relief, and movement speed.

5.1.3. Change of electromagnetic field distribution in the DZ can be caused not only by an intruder but other factors: rain, vibration of grass, small animals, electromagnetic interference, swinging of branches, gates entering the detection zone commensurable with an intruder movement. Other reasons, e.g. location of extensive constructions, objects in the detection zone or near from it like as fences, walls, irregularities, snow, grass can influence on the level of Rx input signal. In these cases because of big reflection and interference the detection zone configuration jumps. Multi thresholds

algorithm of the sensor operation permits to decrease the number of alarms provoked by interference. **That's why it is necessary to observe the recommendations in the subsection 8.1 (especially for the sector of the sensor mounting)!**

5.2. Adjustment, Control and Indication Parts

5.2.1. An alarm generates the values of the Rx thresholds. An explorer establishes them during the operation with the thresholds controller "MIN-MAX". The thresholds adjustment is realized by the main rotation of resistor axis with screwdriver. In this case the thresholds will change from minimum (MIN) to maximum (MAX) value.

5.2.2. The input signal is controlled with the tester on the socket that is marked "TEST" (below "the voltage TEST"). The more TEST voltage the more Rx input signal and vice versa.

The sensor keeps its operation with the range of the voltage values too: TEST 0,1-4,8V.

5.2.3. The light indicator "Protection" provides the indication of the sensor mode operation:

- Continuous luminescence means the standby state of the sensor;
- Switching off the indicator for 3sec means the alarm generation.

Pressing "AGC" button on Rx it is possible a broken glow of the indicator "Protection". To decrease power consumption, the indicator "Protection" goes out after 10 min of the sensor operation in the standby state if there were no pressures on the button "AGC", the turn of the levels controller, transfer of the sensor in the alarm mode. In this case the indicator disconnection doesn't influence on the state of the relay contacts.

5.2.4. During Rx and Tx adjustment on the maximums of the antennas directional diagrams, the amplifier is transferring from the mode of the automatic gain control with a big time constant to the mode with a small time constant by pressing the button "AGC" on Rx. In this case an express setup of the amplifier takes place on the standby state.

5.2.5. A "normally closed" tamper loop is provided to prevent unauthorized opening of the back panel of the Rx unit. In the operating condition the tamper circuit's contacts are closed, during the back panel opening they are broken. The alarm cables circuits marked "TAMPER" (green and grey wires) are broken too.

5.3. Sensor Operation

5.3.1. The sensor operation provides the following steps:

- Preparation of the sector
- Signal cables laying and power supply
- Tx and Rx installation
- Sensor connection (connection of power supply and loops of intruder alarms)
- Alignment of Tx and Rx antennas
- Setup of Rx thresholds.

The principles and the methods of the operations' performance are given in items 8-10.

5.3.2. The sensor has the following modes of operation:

- Standby state (contact breaking)
- Alarm signal (open condition)
- Opening state of Rx according to the contacts button "TAMPER".

5.3.3. The receiving-control device realizes the receipt and the indication of alarms. The sensor operates with the receiving-control devices providing the relay contacts check.

5.3.4. During the operation the remote control checks the sensor efficiency. The control is realized by the signal "RC" from the duty operator with the constant voltage 5...30 V for 1...3 sec. The beaming of Tx is interrupted for the time of the signal "RC" operation. Then Rx generates an alarm. In such a way **the signal generation after the signal "RC" confirms the sensor operation and the running order of the tail.**

The user determines the control periodicity.

5.3.5. Besides there it is necessary to check periodically the technical state of the sensor and its servicing. Periodicity of the checks is given in item 11.

6. SENSOR CONSTRUCTION

6.1. Rx-3, Rx-3/1, Rx-3/2

6.1.1. The sensor consists of separate units (Rx, Tx) placed in dust-, splash-proof enclosures.

6.1.2. Rx construction and its fastening elements to the support are given in fig. 6.1. The receivers of different sensor modifications differ from them by overall dimensions.

The carrier of the unit is base 4. Radio transparent enclosure 5 is glued to the base with sealing material. In the heel of the enclosure there are two holes preventing condensed fluid accumulation within the unit. The access to the controls, adjustment, indication elements and clamps for the connection of the terminal element is open when cover 6 is removed. Rx is connected to the receiver control device with six wires cable 8. Rx is mounted on the support 1 using bracket 2 and two clamps 13. Mounting provides the rotation of the unit horizontally at angle $\pm 65^\circ$ minimum; vertically: upward - at angle 30° minimum, downward – at angle 45° minimum. Location and marking of the clamps, controls, adjustment and indication elements located under cover 6 are shown in fig. 6.2.

6.2. Tx Construction (Tx-3, Tx-3/1, Tx-3/2).

6.2.1. Tx construction and its bracket are the same as the Rx construction (see fig.6.1). The difference is in internal elements: there is not cover 6, there are not clamps, controls, adjustment and indication elements, three wire cables are used instead of six wires cable 8.

6.3. MK (mounting kit)

6.3.1. Mounting kit for FMW-3 includes two brackets and four clamps for the mounting on the support of Rx and Tx. Mounting kit for FMW-3/1 and FMW-3/2 has the same mounting kit but the brackets have other length.

The MK for Tx, Rx fastening on the wall can be delivered too on the customer demand.

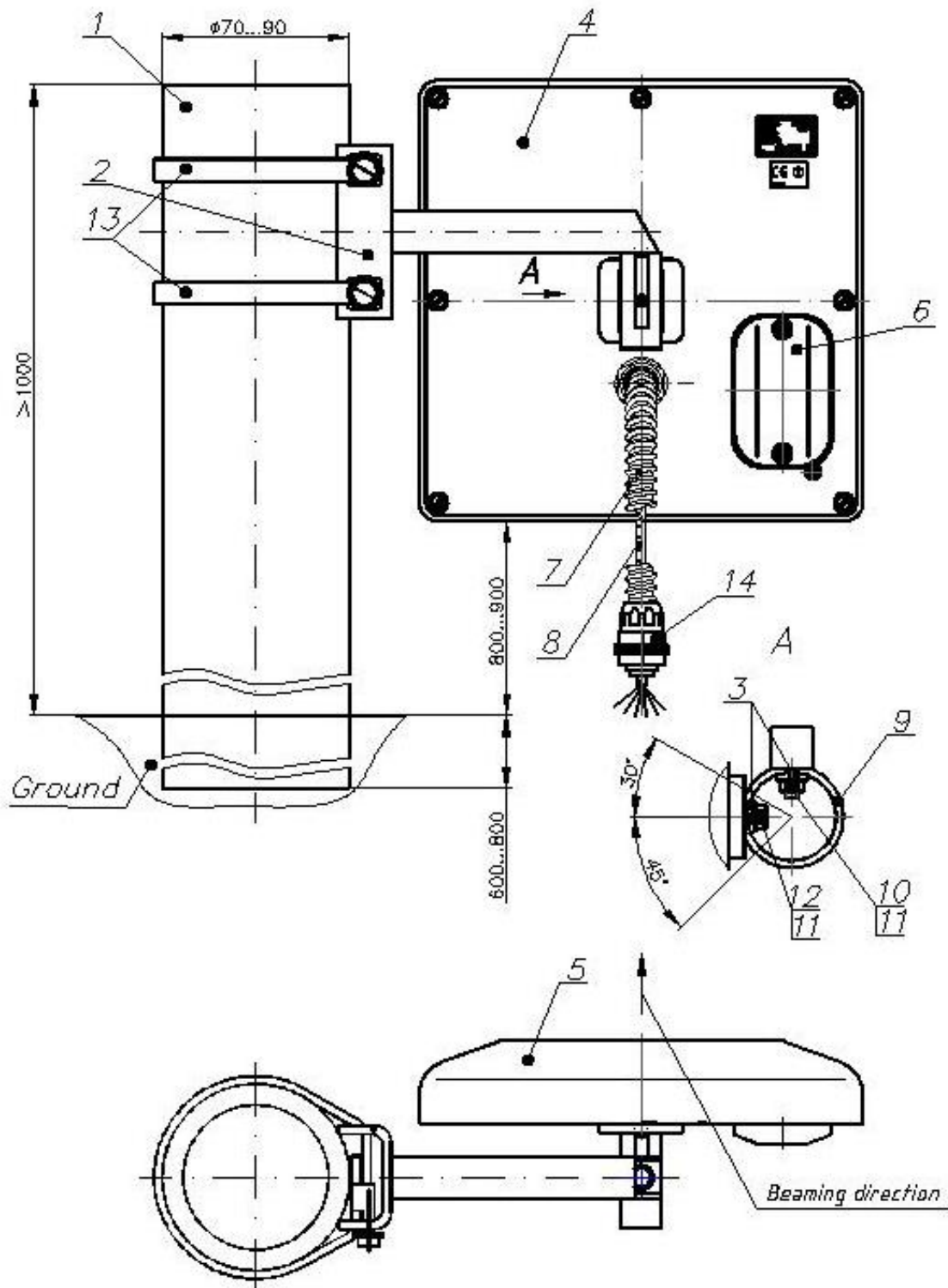

- | | |
|---------------------------|-----------------------|
| 1-support (tube) -1 item | 8-cable-1 item |
| 2-bracket -1 item | 9-ring – 1 item |
| 3- figured washer-2 items | 10-nut M6-1 item |
| 4-base -1 item | 11-washer 6 -2 items |
| 5-enclosure- 1 item | 12-bolt M6*16 - 1item |
| 6-cover-1 item | 13-clamp- 2items |
| 7-corrugated tube -1 item | 14-insert-2 items. |

Fig.6.1

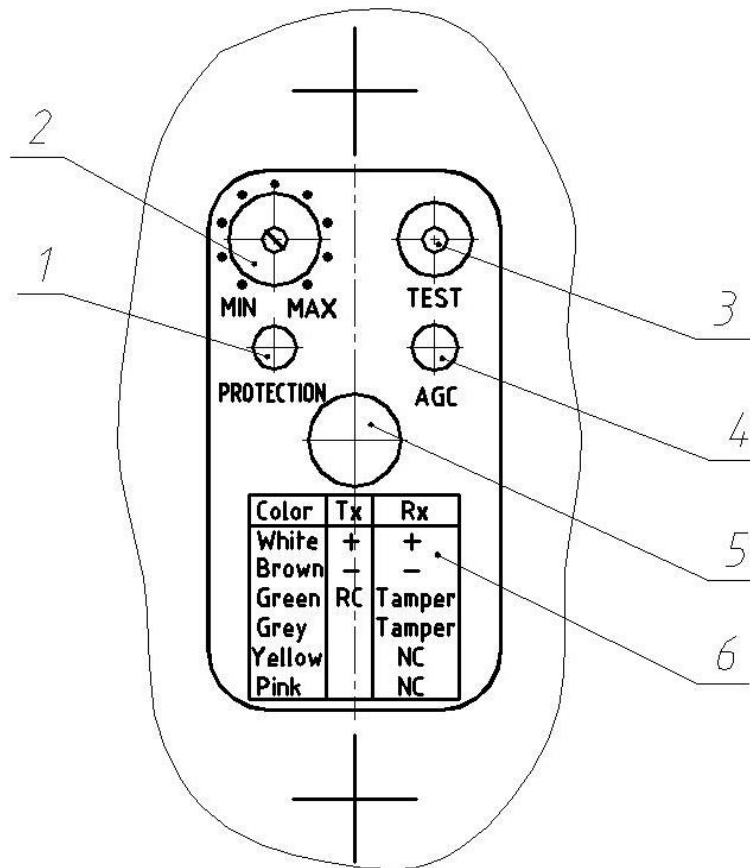

- 1 - indicator "PROTECTION"
- 2 - threes holding "MIN-MAX"
- 3 - socket "TEST"
- 4 - "AGC" button
- 5 - tamper circuit
- 6 - marking of cable cords

Fig.6.2.

Note. Dear user! Manufacturer of "FMW-3," "FMW-3/1", "FMW-3/2" sensors constantly upgrades their quality and reliability. That's why in some lots of sensors one can find design modifications unspecified in the documents delivered with the sensors. Nevertheless, the main specifications are valid.

7. SAFETY MEASURES

7.1. The current safety standards for the operation with electrical facilities with up to 1000 V voltage should be observed during mounting, prevention and repair of the sensor.

7.2 Cables should be laid, terminated and connected to the sockets only when supply voltage is OFF.

7.3. The maximum value of SHF energy flux average density at the distance of 1 m from the sensor does not exceed 1 micro W/cm² that satisfies the security standards for people who don't work with SHF.

7.4. It is prohibited to mount and to maintain the sensor during lightning storm.

7.5. The sensor can be mounted and repaired only by the technicians who learn special instructions and pass the examination on safety measures.

8. MOUNTING PROCEDURE

8.1. Requirements for the preparation of the sector and the arrangement of Rx and Tx

8.1.1. The sector where Tx and Rx are located should meet the following requirements:

a) The height of irregularities should not exceed 0,3m. If irregularities of the sector surface from the plane exceed $\pm 0,3m$; the specifications of the sensor can worsen. In this case the issue of the use of the sensor under these conditions is defined by the trial operation.

b) The height of grass should not exceed 0,3m;

c) The height of snow should not exceed 0,5m;

d) The maximum incline of the sector is 45°;

e) Single fixed objects (e.g. posts, trees without lower branches) can be situated in the detection zone at the distance of 1m minimum from the axis;

f) On the sector there **should not be situated** moving leaves, bushes, trees and etc. at the distance of 1m from the detection zone;

g) The width of the zone should meet item 3.3.

The sensor can be mounted if the width of the sterile zone is less. In this case if voltage "TJ" (item 9.2.) is less than 1,2 V, it is necessary to change Rx and Tx position relative to the support. For example, if Rx and Tx are to the left from the support, turning the bracket relative to the support at 180°, fix Rx and Tx at the right from the support. If it is not successful and voltage TJ is less than 1, 2 V, it is necessary to realize the trial operation and according to its results to make a decision about the possibilities of the sensor operation in these conditions.

8.2. Sensor Mounting

8.2.1. Mark the perimeter for the places where the supports are mounted. To exclude zones of intermittent detection of the antennas the supports should be mounted with overlapping (see fig.8.1. and 8.2.). The overlapping is necessary to avoid "dead zones".

8.2.2. Mount the supports. It is recommended to use metal or asbestos-cement tube as supports of 70...90mm diameter. The height of the support above the surface of the ground is given in fig.6.1. In the places where there is a lot of snow, the superstructure of the support should be 1500 mm minimum.

Procedure of Tx and Rx Mounting in the Protected Perimeter

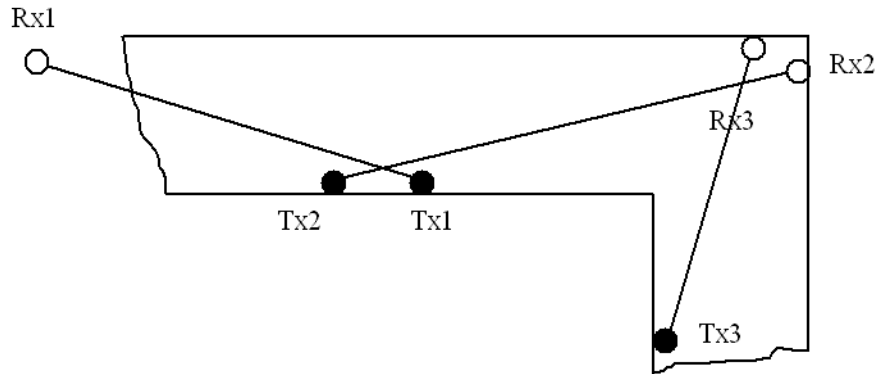

Fig.8.1.

Mounting Variant of Supports of Two Adjacent Sensors

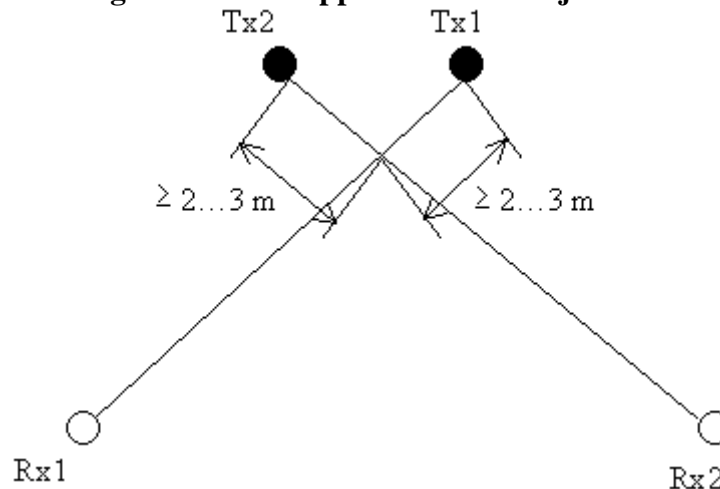

Fig.8.2

8.2.3. The supports are mounted with concreting. The recommended dimensions of the concrete layer are given in fig.6.1.

The user can apply other variants of the sensor mounting (for example guarding, building wall) according to the results of the trial operation. As the guarding deforms the detection zone configuration, the sensor operation depends on the exact place of its mounting.

8.2.4. Lay the main cables on the fence or in the air according to the project of the security systems.

Mount the brackets on the supports for Rx and Tx. The brackets of Rx and Tx (for a sector) should be adjusted. The height of the brackets mounting when snow is absent is chosen according to fig.6.1. The wall brackets are mounted on the supports with two clamps (see fig.6.1).

8.2.5. Mount Tx and Rx on brackets with bolts 12 (fig.6.1).

ATTENTION! The right orientation of Tx and Rx on the wall bracket - drain port should be downward!

Pass the cable 8 in the corrugated tube 7. The installation of the corrugated tube is obligatory.

8.2.6. Mount the junction boxes and supply units PSU if the project includes it. In the case of the boxes "Barrier -JB" and supply units "PSU 24-0,7" using they will be mounted on the supports with the sensor units. To pass the cable 8 in "Barrier-JB" (or "PSU") (fig.6.1) protected by the corrugated tube 7, it is necessary to remove one of pressure seals PG9 JB (or "PSU") and to install the insert 14 with the corrugated tube 7 in the hole. It is recommended to use one "PSU 24-0, 7" for power supply of two adjacent sensors. There are five free terminal blocks ("1" - "5") in "PSU 24-0,7". That's why the junction box can be without mounting on the support where "PSU 24-0,7" is mounted. The boxes "Barrier -JB" and "PSU 24-0, 7" are fixed to the supports with the same clamps as the

sensor units. The mounting parts are the part of the delivery kits of the boxes “Barrier –JB” and “PSU 24-0,7”.

ATTENTION! To reduce the level of electromagnetic interference induced on supply lines, it is recommended to mount PSU at the distance of 300m maximum from the place where the sensors are installed.

8.3. Sensor Connection

8.3.1. Switch ON the necessary supply units, signal and remote control circuits. Rx and Tx units are connected with its own cords. The wires are marked. The marking of cable conductors is given in table 8.1.

Table 8.1

Rx			Tx		
Circuit	Color	Purpose	Circuit	Color	Purpose
“+”	white	Supply voltage	“+”	white	Supply voltage
“-“	brown		“-“	brown	
“NC”	yellow	Individual point relay contacts	“RC”	green	Remote control +5...30 V
“NC”	pink				
“TAMPER”	green	Contacts of the tamper circuit			
“TAMPER”	grey				

8.3.2. The type and the nominal of the terminator of the security systems loop (resistor, condenser, and diode) are determined by the type of the receiving-control device. The sensor is connected to the receiving-control device. Usually it is a resistor. The nominal resistance of this resistor should take into the contacts resistance of the individual point relay (≈ 30 Ohm) and clamping resistor of the lightning circuit (this resistor - 100 Ohm) and resistance of the security systems loop (depends on the chosen cable type and its length).

FMW-3 connection by transit through Tx unit

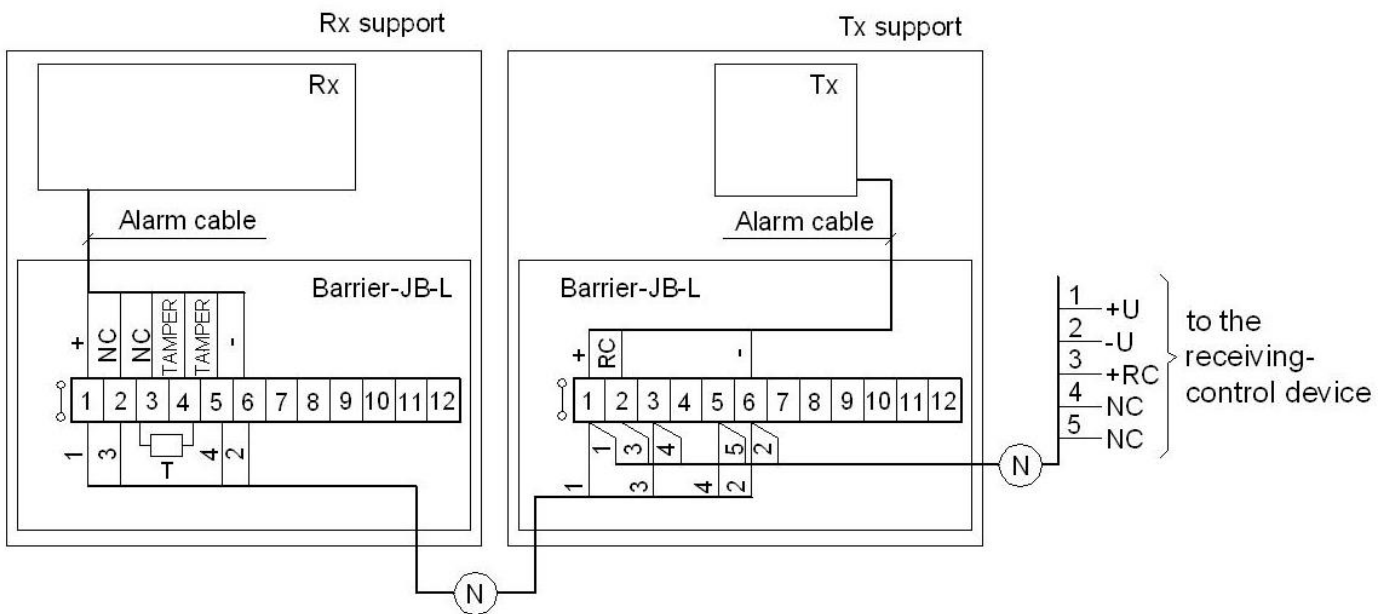

FMW-3 connection by transit through Rx unit

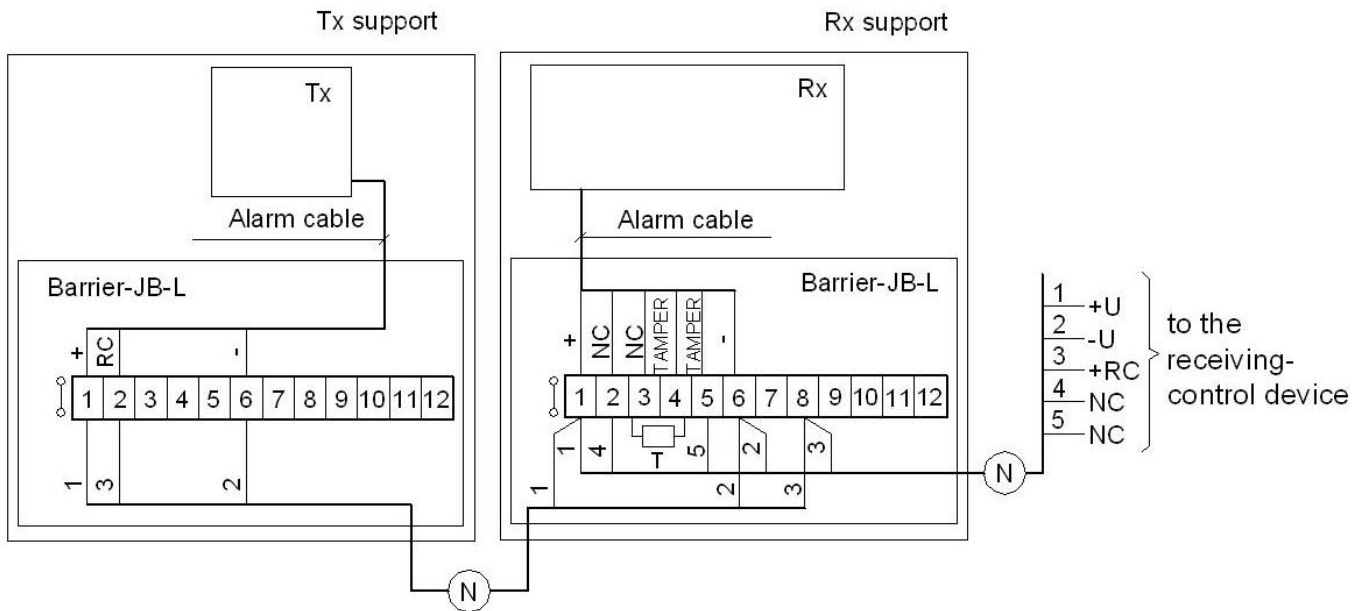

T-terminator of the receiving-control device

Fig.8.3

FMW-3 connection by transit through Tx unit (through LGU-4)

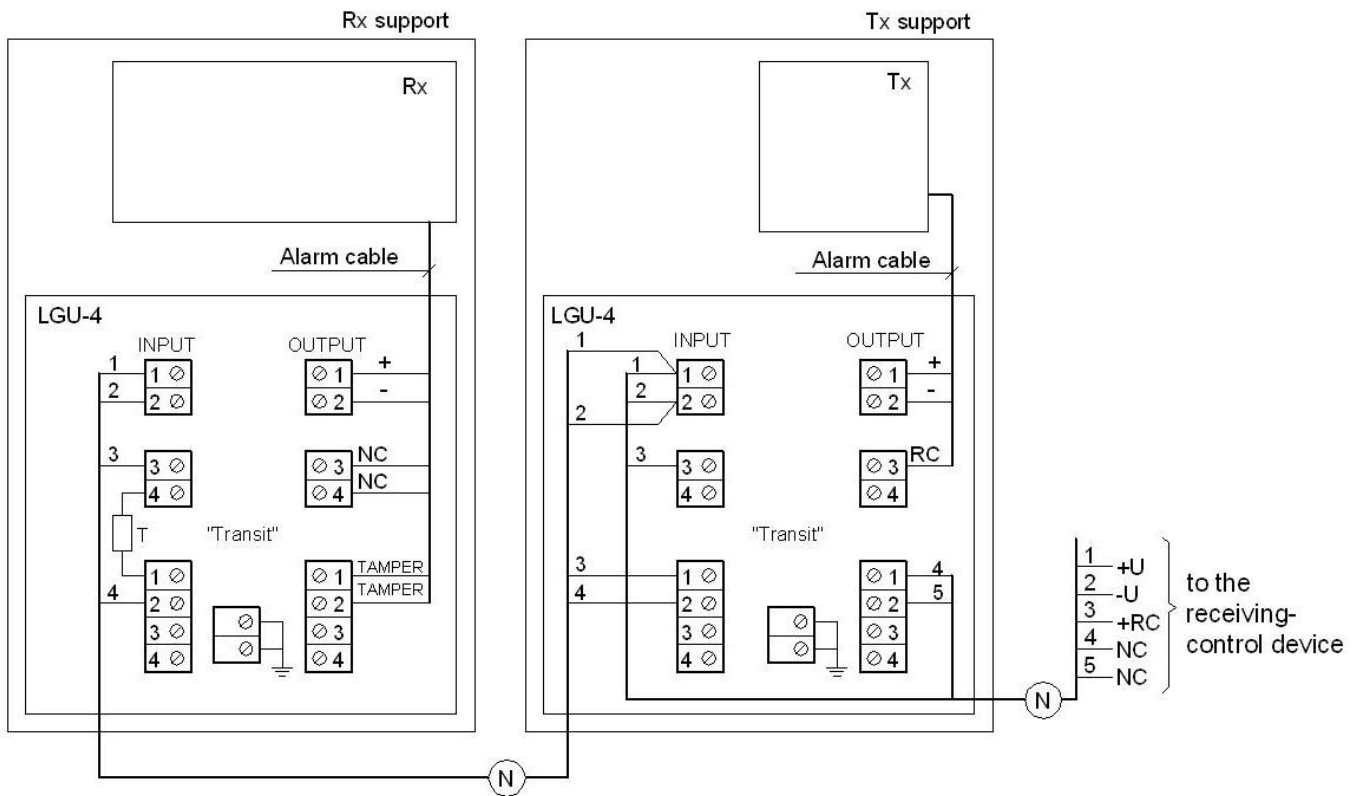

FMW-3 connection by transit through Rx unit (through LGU-4)

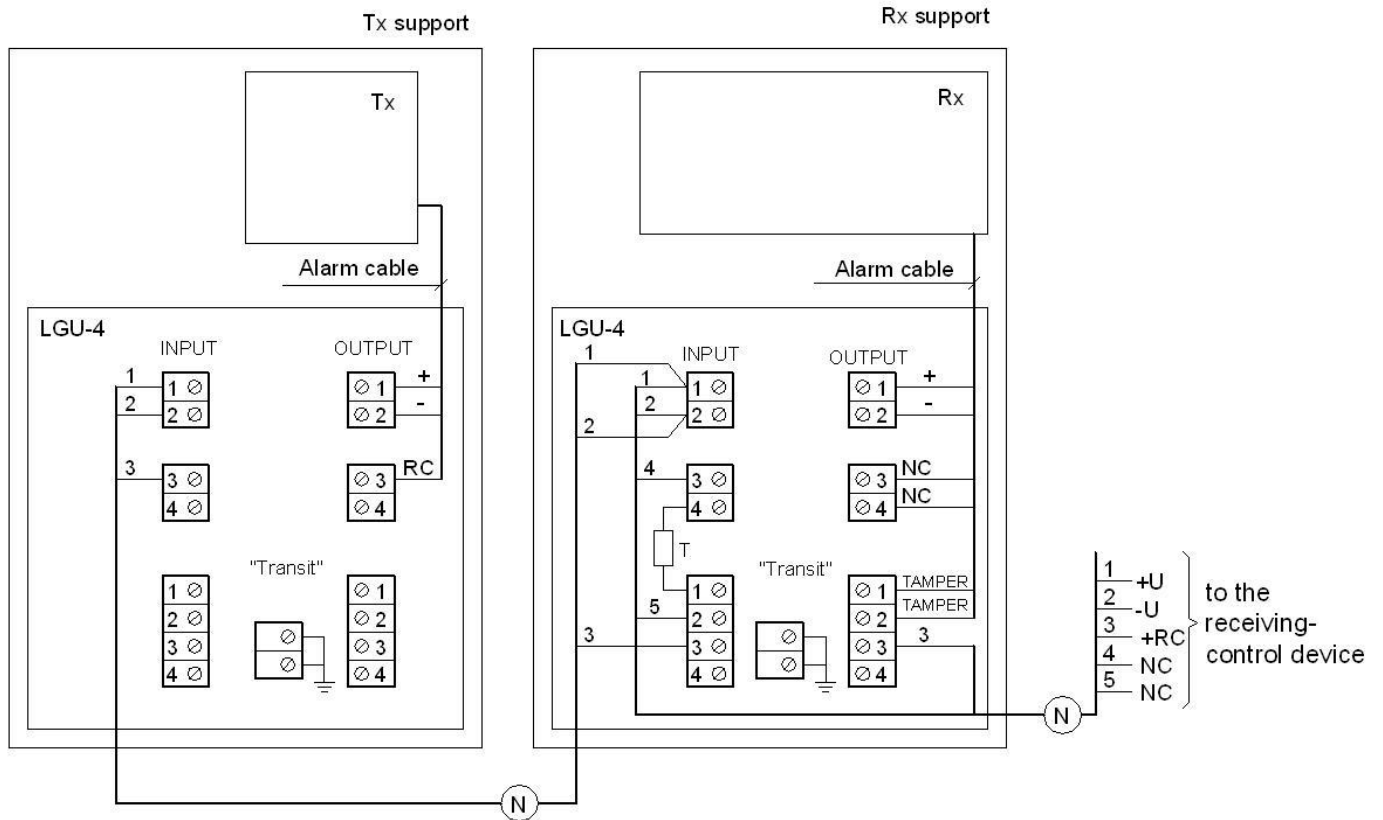

T-terminator of the receiving-control device

Fig.8.4

FMW-3 connection from PSU-24-07

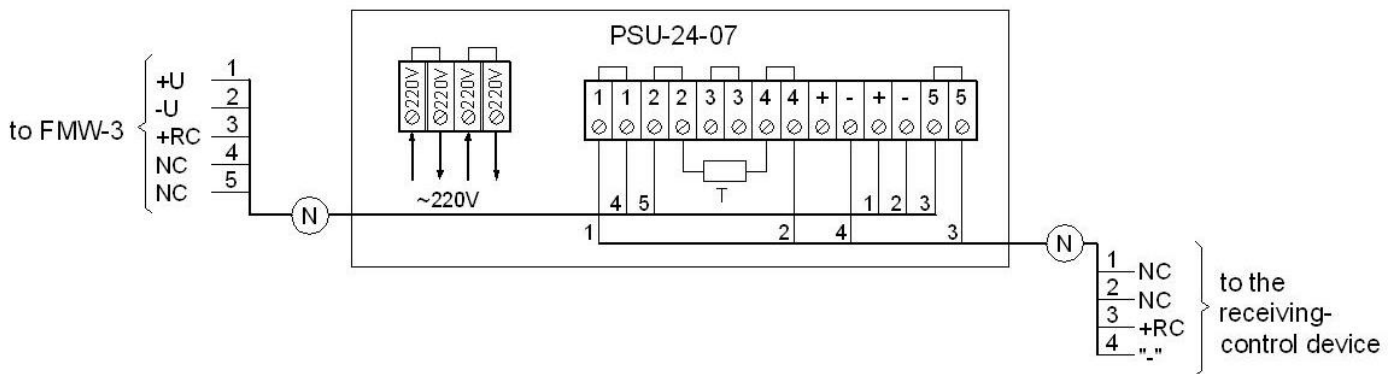

T-terminator of the receiving-control device

Fig.8.5

8.3.3. The contacts of Rx tamper circuit (TAMPER) can be connected to the control device by the separate loop. In this case the user receives the information of the Rx terminal cover with the separate signal. The second variant of the cover connection: the individual point relay is switched ON in series because the contacts are normal closed too (they will be opened during the opening of the Rx terminal cover). In this case an alarm will be generated when:

- the individual point relay functions;
- Rx terminal cover on one channel of the receiving-control device is opened.

8.3.4. There is a scheme (see fig.8.3) of the sensor connections using the junction box “Barrier-JB”. The contacts of the tamper circuit will be switched ON in series with the relay contacts. The sensor receives a signal from the remote control (RC) when an additional button is installed in the room. It is possible to install one button on some sensors. In this case the button pressing checks the sensors operation of all sensors group.

There is the model scheme of the sensor connection using the storm protection unit “LGU-4” (see fig.8.4.).

There is the model scheme of two sensors connection to the supply unit “PSU 24-0, 7” (see fig.8.5.).

8.3.5. To extend the perimeter sites for object cables switching, it is recommended to use the junction boxes “Barrier-JB” (on 30 circuits), “Barrier-JB-B” (on 48 circuits) or “Barrier-JB84” (on 84 circuits).

9. SENSOR PREPARATION FOR THE OPERATION AND ADJUSTMENT

9.1. Sensor Preparation for its Operation

Check the right connection of supply circuits and output circuits of the sensor.

9.1.1. Switch ON the sensor power supply. The broken or constant glowing of the indicator “Protection” proves the presence of voltage on Rx.

9.2. Tx and Rx adjustment

9.2.1. Tx and Rx are adjusted on the angle of the place and the azimuth according to the maximum value of voltage TEST (on the output of Rx).

9.2.2. Two persons are necessary for the adjustment. One of them is situated next to Rx, the other – next to Tx.

9.2.3. The alignment includes the following order:

- Connect the tester to the socket “TEST” using the alarm cable from the kit in the mode of constant voltage measuring;

- Loosen the bolts 12 (see fig.6.1) of Tx and Rx;

- Press the button “AGC”. Pressing it and stooping in turn Tx and Rx vertically, exact the maximum indicated value of voltmeter. Ease the button “AGC”.

- Tighten the bolts 12;

- Loosen the nuts 10;

- Check the value of “TEST” voltage as a result of the adjustment. If “TEST” voltage is less than 1,2 V, it is necessary to repeat the alignment vertically and horizontally for more exact adjustment. If the voltage controlled by the voltmeter is over 4,5V (on short sectors), **it is recommended to make the desalignment of Rx and Tx upwards at a small angle so the voltage does not exceed 4,5V. Don't desalign Rx and Tx down or towards.** The sensor keeps its operation using “TEST” voltage 0,1...4,8V. The boundary values of 1,2V and 4,5V during the adjustment are recommended for the resource of the signal level to provide a long operation;

- Disconnect the tester from the socket “TEST” of Rx.

9.3. Rx threshold

9.3.1. Mount the tester “MIN-MAX” in the position MAX.

Thresholds are adjusted when a person crosses a protected sector uniformly along the whole length. Cross the sector in the position “at one's full height” and “having bent”. The investigator should go out from the DZ of 1-2 m for Rx calming (otherwise the results of the previous passage will influence on the following). When the sensor generates alarms, “Protection” indicator becomes dim for 3 sec. After the switching ON of the indicator “Protection”, the following passage can be done. If the controller of the thresholds is turned clockwise the value of the sensor thresholds increases and vice versa. If the signal is not generated during the investigator passage, the controller “MIN-MAX” will be turned on one-two points counter-clockwise and the alignment will be continued.

Do some check passes along the whole length of the sector especially in the “problem” sector places: in hollows, hills, next to the trees branches situated in the detection zone. If it is necessary regulate the sensor thresholds.

Notes. During the check passes at mean speed the thresholds values detect an intruder moving at a speed 0,3...10m/sec. To extend the speed range up to 0,1...10 m/sec adjust additionally the thresholds crossing a sector at a speed of 0,1 m/sec.

Align the thresholds very attentively because “decreasing” the thresholds a lot of false alarms can be generated because of some interference; “increasing” the thresholds some sensor omissions appear in its operation.

When the adjustment is over, it is necessary to close Rx terminal cover.

After the sensor adjustment it is recommended to carry out its trial operation for 2...3 days to reveal and eliminate possible errors of mounting and adjustment.

10. SENSOR OPERATION WITH THE DEFLECTOR

10.1. If it is necessary to create breaking of detection zone, the sensors “FMW-3”, “FMW-3/1”, “FMW-3/2” can be used with the deflector (fig.10.1).

10.2. A metal sheet (its dimensions no less than 1*1m) is used as a deflector. During mounting the deflector should be adjusted at the angle of azimuth and the angle of the place. It should have reliable fastening to exclude its vibration when it is windy because it can cause false alarms.

10.3. In case of operation with the deflector the total length of the detection zone does not exceed 130m for “FMW-3”; 50m maximum for “FMW-3/1”; 25m maximum for “FMW-3/2”.

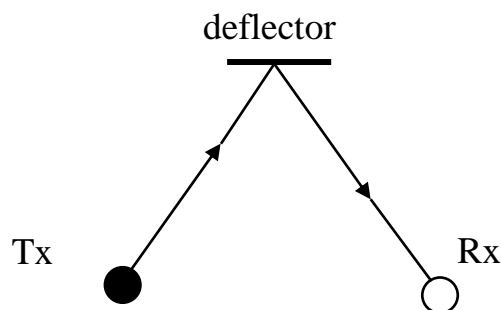

Fig.10.1

10.4. Procedure of Operation

10.4.1. Mount Tx and Rx according to item 8.2.

10.4.2. Align Tx and Rx antennas in the direction of the deflector. Open Rx terminal cover and connect the tester to “TEST” socket with the alarm cable. Switch ON supply voltage.

Changing the position of the deflector, Tx and Rx units obtain the signal on the output of the amplifier. Carry out exact alignment according to item 9.2.

10.4.3. To define the optimal position of the deflector, it is possible to use a laser pointer. Place a mirror on the deflector (the plane of the mirror should be parallel to the plane of the deflector) and fix the pointer (keep it) in the center of Tx unit. Direct the pointer beam on the mirror center.

Changing the position of the deflector it is necessary to obtain the beam from the pointer to be in the center of Rx antenna.

Switch ON supply voltage and carry out the exact alignment of Rx, then the alignment of Tx according to the methods given in clause 9.2. Adjust the operation thresholds of Rx according to methods given in clause 9.3.

11. CHECK OF TECHNICAL STATE

11.1. Check of Sensor Operation

11.1.1. During the sensor exploitation it is recommended to check remote control (RC) 1...3 times in a day.

11.2. Servicing

11.2.1. The sensor should be served by the technicians after special training and instruction.

11.2.2. During the service of the sensor it is necessary to conduct the check and the preventive works.

11.2.3. Every month carry out external examination of the sensor units and the state of the sector where Tx and Rx are installed.

It is necessary to check:

- the absence of dust, dirt, snow and ice from the side of radiation of Rx and Tx antennas and clean them if it is necessary;

- the absence of outside objects in the sector where Tx and Rx are installed.

11.2.4. Every quarter:

- carry out all the works specified as works carried out every month;

- check the state of the cables and cable connections.

11.2.5. During seasonal works the height of the grass is controlled. If the height of the grass is over 0,3m, the grass should be cut or removed by another method.

11.2.6. If the height of snow changes, false alarms can be generated because of the decrease of the signal at the input of the receiving unit. In this case it is necessary to remove snow or to change the height of Tx and Rx antennas installation.

After the height of the antenna mounting is changed, they should be aligned. The thresholds should be adjusted according to the procedure given before.

12. TROUBLESHOOTING GUIDE

List of possible troubles is given in table 12.1.

Table 12.1

Trouble	Possible Cause	Repair
1. The receiving-control device constantly generates alarms	1. Communication line is broken.	Check the cable integrity and the accuracy of its connection. Restore the communication line.
	2. The protective device in the supply unit is blown.	Replace the protective device.
	3. The sensor alignment is disturbed.	Align Tx and Rx antennas.
	4. Tx fails.	Replace Tx.
	5. Rx fails.	Replace Rx.
2. False alarms of the sensor	1. Moving branches are in a detection zone and they cause alarms.	Inspect the sector and remove interference factors.
	2. High grass is in the sector.	
	3. Snow blanket is higher than one specified in the manual and this reduces an input signal.	
	4. Animals circulate in the sector.	
	5. The Rx thresholds are too low.	Check the accuracy of the Rx thresholds

Trouble	Possible Cause	Repair
3. The sensor does not generate alarms when an intruder crosses the sector	1. Rx thresholds are too high. 2. The alignment is disturbed.	setting. Check the accuracy of the Rx thresholds setting. Align Tx and Rx antennas.

13. STORAGE

13.1. The sensors should be stored in the package in warehouses at an ambient temperature +5°C...+30 °C and relative humidity 85% maximum.

During the storage the influence of hostile environment should be prevented.

14. TRANSPORTATION

14.1. Packaged sensors can be transported by any transport (if by plane – in pressurized modules) if they are transported in covered cars, holds or covered bodies they can be transported at the distance up to 10 000 km.

The boxes should be placed to prevent their shifting or fall in case of jolts and blows.

**Microwave Linear Intrusion Sensors
“FMW-3(50m,100m,200m)”**

Certificate

Document Part Number 4372-43071246-004

The purpose of the sensor and its specifications are given in the corresponding clauses of the data sheet of the Document Part Number 4372-43071246-004.

1. DELIVERY KIT

The delivery kit includes:

Transmitter	1 item;
Receiver	1 item;
Mounting kit	1 kit;
Kit of tools and accessories	1 kit;
User manual, certificate	1 item.

2. ACCEPTANCE CERTIFICATE

The sensor “FMW-3_____№_____” meets performance specifications of the Document Part Number 4372-43071246-004 and it is considered as operable.

Date of issue _____20__ .

Quality department

3. MANUFACTURER’S GUARANTEES

The manufacturer guarantees the conformity of the sensor specifications to requirements of the Document Part Number 4372-43071246-004 if a user meets the service conditions and operating rules specified by the Document Part Number 4372-43071246-004.

Warranty period is 24 months since the date of sale by the manufacturer.

Guarantees do not cover the sensors:

- with broken guarantee stamps;
 - with mechanical failures,
 - and also those which are out of order because of natural disasters (lightning, fire and flood).
- Mean lifetime is 8 years.

For warranty and post-warranty service you can contact:

European Office:

JCS “Forteza”

Tilzes str. 38

91112 Klaipeda

Lithuania

Phone+370 46 411353

Fax+370 46 412231

E-mail forteza@forteza.com

