

The Future of Cyber Gauges is Here and Now.

USER'S MANUAL

CYBER GAUGE

OBD or SENSOR SYSTEM

Sensor Connection

WATER TEMP	CSW
OIL TEMP	CSO
OIL PRESSURE	CSP
VOLTAGE	COV
SENSOR UNIT	CSU

Thank you for purchasing this PIVOT product.
Please read this manual carefully and keep it for future reference.

● If this product is given to another user, make sure to include this User's Manual.

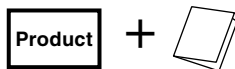

Contents

Contents / WARNING / CAUTION 1
 Features 1
 Part Names and Displays 2
 Connecting The Wires 2~3
 Installing The Product..... 3
 Basic Operation 4
 Switching The Display and Setting 4
 Troubleshooting 4

Please check the contents of the package

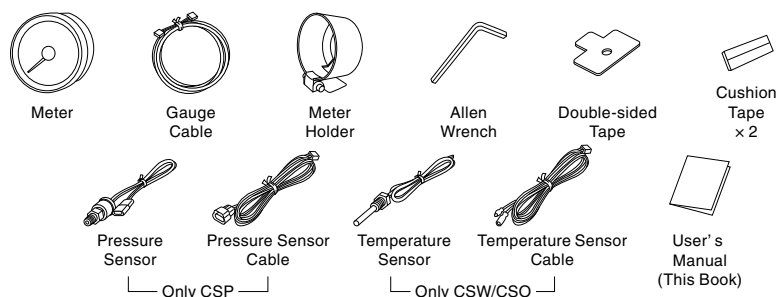

! Need to purchase separately sold Sensor Unit (CSU) to operate meter.

The contents of the Sensor unit package

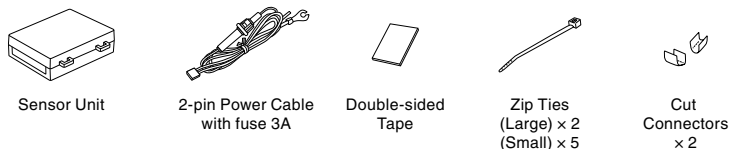

! WARNING Improper use or disregard of these warnings may result in the injury or death of people.

- **Do not work in areas where there is excessive exhaust.**
Due to vehicle exhaust emission poisoning or fire may result in a damage to humans.
- **Do not crush the cable.**
Please be careful that the cable does not get crushed by the seat rail or car door steel plate, nor cut by any sharp steel plate as this may cause a poor connection or an electric short leading to fire or other danger.
- **Do not operate while driving.**
Operating or checking the display during driving may cause an accident; please use with the utmost consideration for safety.
- **Please securely fasten the product to a stable place and be sure to store bundle away all wires with tape, etc...**
It is very dangerous to pull tangled wires by force or allow tangled wires to interfere with driving.

! CAUTION Improper use or disregard of these warnings may cause injury to persons, damage the product and other things.

- **This product is for DC12V cars;**
Installation cannot be carried out on cars with other voltage batteries.
- **Just after installation do not exert any strong force on the product.**
When double-sided tape is used for an installation be warned that when hot the tape temporarily loses adhesiveness.
- **Do Not Use Chemical Cleansers.**
If the unit gets dirty please wipe with a soft cloth to remove any dirt. Do not use chemical cleansers such as thinner, benzene, or alcohol.
- **Do not install the product in any place subject to high temperature or any place where water may be splashed.**
- **Make sure to replace all screws and parts to their original place.**
- **Do not install the product in a place where it will cause distraction.**
- **Do not, in any manner, process, take apart, or make changes to this product.**

Features

Sensor Connection Models

Wide Range Compatible Sensor Connection Models

*Sensors for display is included

Low Position Holder

New meter gauge holder allows for installation at 5 mm lower than normal.

Illumination

White LED lighting of Dial and Needle.

Warning and Peak reading

Blinks red LED at the set value as Warning and the Peak reading.

Stepping Drive

Our stepping motor is able to provide a smooth, highly precise display.

Linkage Possible

For a sleek one-line connection from multiple gauges to unit use our link cable (sold separately).

Part Names and Displays

[Meter]

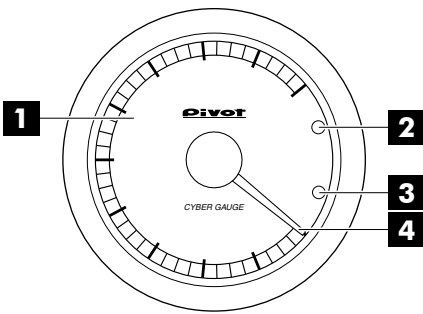

- 1 Display** Display each data
- 2 LED** Blinks red LED at the set rpm and the Peak reading.
- 3 Switch** Use to set the warning and display and reset the peak value.
- 4 Needle** Shows the current values and peak value.
- 5 Illumination** Normally illuminated when on display. (dial : white, needle : white)
- 6 Meter connector** Connect gauge cable
- 7 Power connector** Connect power cable
- 8 Pressure connector** Connect Pressure Sensor
- 9 Oil temp connector** Connect Oil temp Sensor
- 10 Water temp connector** Connect Water temp Sensor

[Unit]

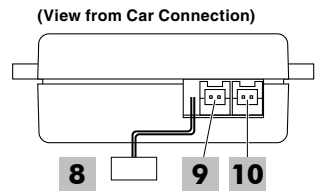
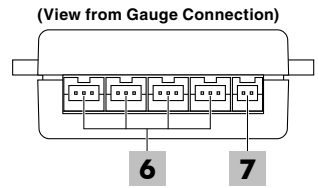

Product	Product Number	Display Range	Warning	Peak
WATER TEMP	CSW	20 ~ 120°C	Over the set value	Maximum side
OIL TEMP	CSO	50 ~ 150°C	Over the set value	Maximum side
OIL PRESSURE	CSP	0 ~ 1000kPa	Under the set value	Lowest side
VOLTAGE	COT	7 ~ 17V	Under the set value	Lowest side

Size
[Unit : mm]

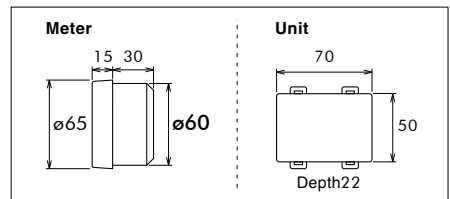

Connecting the Wires

Basic Wiring

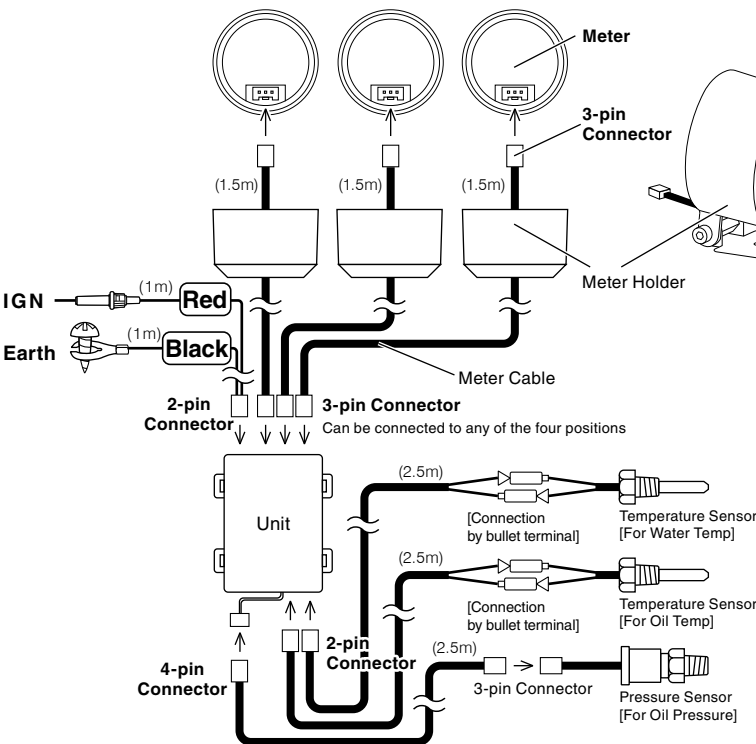

Link Wiring (Link Cable is separately sold)

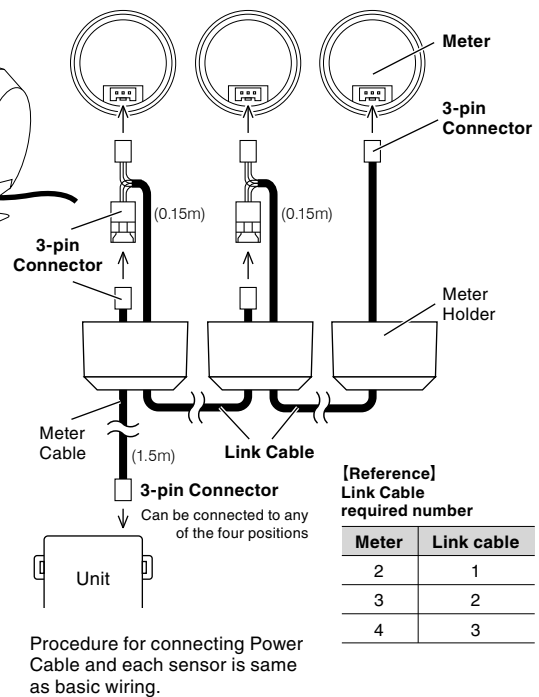

Meter can be connected to up to four in both basic and link wiring. For link wiring, need to purchase separately sold link cable in accordance with the number of the meter.

IGN

Red Connect to the IGN (12V with key ON) using the cut connectors (included). (Do not connect to ACC)

Earth

Black with earth terminal Fasten to a screw of a metal part which is earthed.

● Painted screws and screws connected to plastic parts are not earthed; make sure to connect only to a place which is earthed.

How to use the Cut Connectors

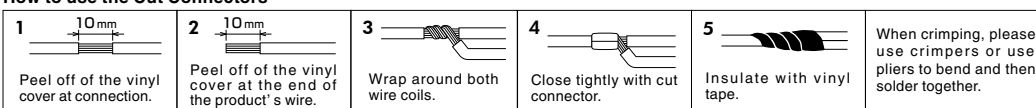

Connecting Sensor

⚠ Depending on the installation you may need a sensor adaptor. (sensor connector 1/8 PT sold separately)

1. Be sure to securely connect the sensor adaptor according to the manual so as to prevent any leakage of water and oil.
2. Be careful not to carry out this installation while engine is hot; it may result in burns or injury. Make sure engine has sufficiently cooled down before attempting installation.

Connecting Water Sensor

Use the hose joint (sold separately) to attach the temperature sensor to the upper hose of radiator.

1. Cut the upper radiator hose at a suitable spot. (Water coolant will spill out, so prepare replacement coolant.)

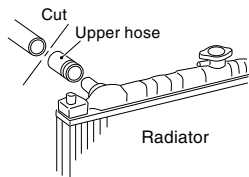

2. Fit the hose band onto the cut upper hose and securely connect the cut hose to the hose joint with the hose band, so as no leakage will occur.

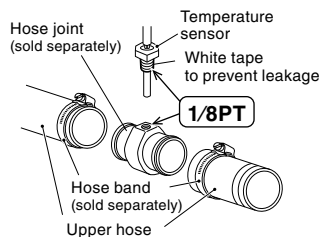

Connecting Oil Sensor

Oil Drain Hole Installation

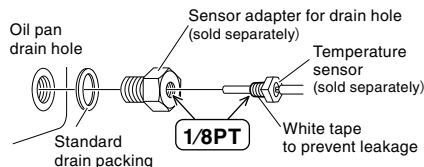

Oil Element Installation

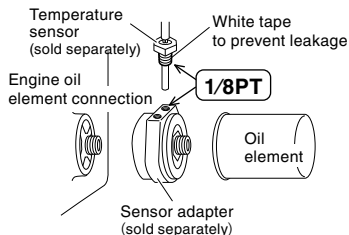

WARNING

For cars chassis that are low to the ground or in cases where road conditions may be poor, please do not use this type of installation. It may lead the sensor to bump against the ground and break or be damaged.

Connecting Pressure Sensor

Oil Element Installation

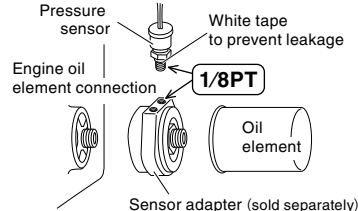

Oil Pressure switch Installation

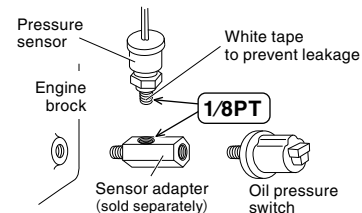

● About SUBARU Horizontally-opposed Engine

If you install in a car with a SUBARU horizontally-opposed engine, and use the screw hole in the oil pump to install the oil pressure sensor, the vibration from the oil pressure may be so great. This may cause damage to the sensor. If you plan to install in such a car model, please use the oil element installation adaptor as shown at right.

Installing The Product

Installing The Meter (Installation with the Meter Holder)

1. Fasten using the double-sided tape. (Clean the surface; removing all oil and dust.)

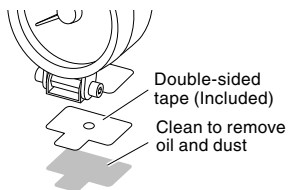

*Please be sure about where you wish to install the meter, as it is not advisable to reuse double-sided tape.

2. After deciding the position and angle of the meter face, fasten the Hexagonal bolt on both sides to secure.

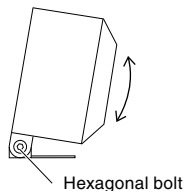

3. Affix Cushion tape on 2 to 4 places to the base of the meter and install the gauge into the Meter Holder.

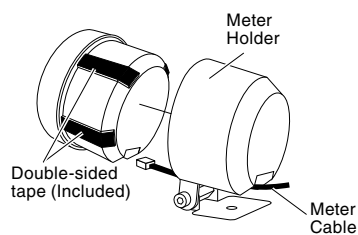

- When using Link Cable, put the connector to the back of Meter Holder as shown in the below diagram. Push the remained cable between the meters to inside of Meter Holder.

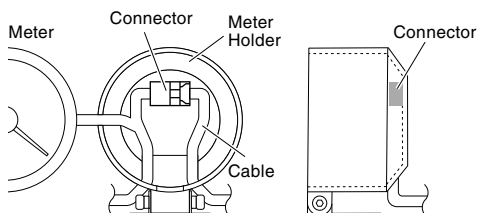

Installing The Unit

Fastening to Flat Space

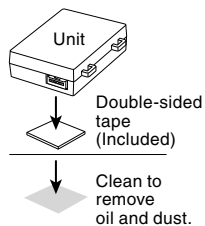

When Fastenings to a Cable or Pipe

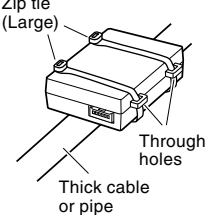

(Example of Installation)

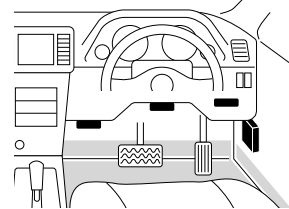

As shown in the above diagram, fasten the unit into positions not usually affected by water.

Basic Operation

- 1 Key Switch ON**
(Engine start)
- 2 Opening Demo**
- 3 Real-time display**
- 4 Key Switch OFF**
(Engine stop)
- 5 Meter OFF**
The needle stops when the key is turned OFF.

Opening Demo

- The needle will move to the lowest value side several times for searching position. Then it will move to the maximum value and finally to reading for current measurement item.

Switching The Display and Setting

Peak reading display

- 1** **Press the switch once**
While the meter is in operation, press the switch once.
- 2** **Peak reading display**
LED will light.
- 3** **Real-time display**
Back to real-time display after 3 seconds releasing the switch.

Reset the Peak reading

- 1** **Press the switch for 3 seconds**
Pressing the switch while displaying the peak reading will re-set the peak reading.
- 4** **Reset the Peak reading**
LED will light off.
- 5** **Real-time display**

Measuring the lowest voltage by voltmeter

- 1** **ON** or **Turn the key switch ON and display the meter**
Without braking, press down twice
- 2** **START** or **Start the engine and check the lowest voltage with Peak reading display**
With braking, press down once

- Recommend to charge or replace the battery if it's lower about 1V or more than when new.

※Each peak value can be reset by the key OFF.

Setting of Warning

※Can't make setting of Warning while displaying Peak reading(LED lighting).

- 1** **Press the switch for 3 seconds**
While the meter is in operation, press the switch for 3 seconds.
- 2** **Setting warning point display**
LED will blink.
- 3** **Press the switch** **Each pressing of the switch will raise, at the maximum point it will return to the minimum point.**
While holding down the switch, change the warning setting.
※By continually pressing down on the switch the needle will move to the maximum point.
- 4** **Release the switch**
- 5** **Real-time display**
LED will light off and back to real-time display after 3 seconds releasing the switch.

Troubleshooting

Trouble	Possible Causes	Possible Solutions
Does not work with Engine start.	Poor connection of Gauge cable , Link Cable or Power Cable .	Please reconfirm whether wiring and connections are correct or not.
Do not show the value with connecting the Temperature sensor.	Poor connection of Temperature sensor or breaking of wire.	Please reconfirm Temperature sensor and whether wiring and connections are correct or not.
Do not show the value with connecting the Pressure sensor.	Poor connection of Pressure sensor or breaking of wire.	Please reconfirm Pressure sensor and whether wiring and connections are correct or not.

Features of the meter

WATER TEMP

For Preventing Overheating and Checking Warm-up

This gauge allows you to not only check warm-up operation but help prevent overheating due to lack of coolant or trouble in the coolant line.

OIL TEMP

For Preventing Engine Trouble

Use not only to check oil cooler performance, but also, prevent engine trouble caused by viscosity reduction due to high oil temperatures.

OIL PRESSURE

For Preventing Trouble from Oil Pressure Loss

Use to check for sudden temporary loss of oil pressure caused by higher rpm in sports driving or tilt in oil level.

VOLTAGE

Battery Checking for New-Era Systems

Use to calculate battery life by checking voltage drop during idling and minimum voltage at start up, as well as, check on your battery recharging status from regenerative braking.

- ※Our products have already been recognized as our Industrial Property or are in the process of receiving Industrial Property status.
- ※We plan in the near future to take all possible legal measures to protect against unfair competition from look-alike products using similar designs, regulating characteristics, circuitry and circuitry layout.
- ※We strictly prohibit the unlicensed use of the PIVOT trademark and the unauthorized use of PIVOT User's Manual.