

# VersaCAMM

Roland DG Corporation

## VP-540 / VP-300

## SETUP GUIDE

### Read this first

This describes the setup tasks and important conditions about the installation location that must be met in order to enable use of this machine.



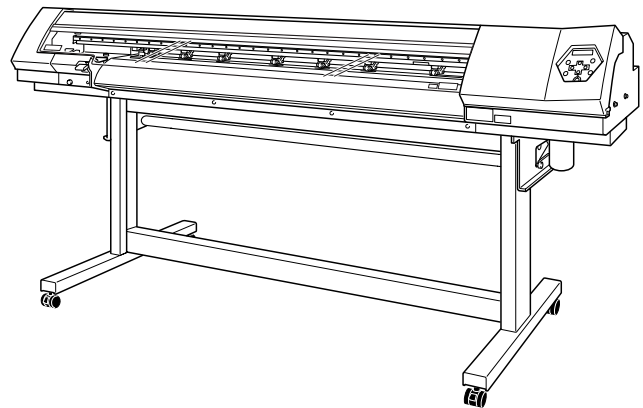

Thank you very much for purchasing this product.

- To ensure correct and safe usage with a full understanding of this product's performance, please be sure to read through this manual completely and store it in a safe location.
- Unauthorized copying or transferral, in whole or in part, of this manual is prohibited.
- The contents of this document and the specifications of this product are subject to change without notice.
- The documentatoin and the product have been prepared and tested as much as possible. If you find any misprint or error, please inform us.
- Roland DG Corp. assumes no responsibility for any direct or indirect loss or damage which may occur through use of this product, regardless of any failure to perform on the part of this product.
- Roland DG Corp. assumes no responsibility for any direct or indirect loss or damage which may occur with respect to any article made using this product.





# Contents

 To Ensure Safe Use .....	4
 Pour utiliser en toute sécurité .....	11
<b>Setup Guide .....</b>	<b>19</b>
1. Included Items .....	20
2. Installation Environment .....	21
Deciding On an Installation Site .....	21
Temperature and Humidity .....	22
Installation Space .....	22
3. Assembling and Installing .....	23
Assembling the Stand .....	23
Installing the Shafts .....	25
Installing the Drain Bottle .....	27
Attaching the Ink-cartridge Tray .....	28
Removing the Packing Materials .....	29
4. Connect the Cables .....	30
Connecting the Cables .....	30
5. Installing the Ink Cartridges .....	31
Filling with Ink for the First Time .....	31
Installing the Ink Cartridges .....	31
6. Installing the Blade .....	35
7. Network Settings .....	37
Introduction .....	37
Step 1: Make the Network Settings for the Computer .....	37
Step 2: Make the Network Settings on the Printer .....	39
Step 3: Make the Port Settings for the Software RIP .....	40
8. When Not in Use for a Prolonged Period .....	41
Keep Performing Maintenance .....	41
Alarm Feature .....	41
Important Note on Draining Ink .....	41
9. When Moving the Unit .....	42
Procedures from Preparing to Move Through Reinstalling .....	42

This document is the setup guide for both the VP-540 and the VP-300. This document uses the following notation to distinguish between the two models where necessary.

VP-540     —   54-inch model

VP-300     —   30-inch model

Also, most of the figures in this document depict the VP-540.

Company names and product names are trademarks or registered trademarks of their respective holders.

Copyright© 2007 Roland DG Corporation



<http://www.rolanddg.com/>





# To Ensure Safe Use

Improper handling or operation of this machine may result in injury or damage to property. Points which must be observed to prevent such injury or damage are described as follows.

## About WARNING and CAUTION Notices

 <b>WARNING</b>	Used for instructions intended to alert the user to the risk of death or severe injury should the unit be used improperly.
 <b>CAUTION</b>	Used for instructions intended to alert the user to the risk of injury or material damage should the unit be used improperly.  Note: Material damage refers to damage or other adverse effects caused with respect to the home and all its furnishings, as well to domestic animals or pets.

## About the Symbols

	The  symbol alerts the user to important instructions or warnings. The specific meaning of the symbol is determined by the design contained within the triangle. The symbol at left means "danger of electrocution."
	The  symbol alerts the user to items that must never be carried out (are forbidden). The specific thing that must not be done is indicated by the design contained within the circle. The symbol at left means the unit must never be disassembled.
	The  symbol alerts the user to things that must be carried out. The specific thing that must be done is indicated by the design contained within the circle. The symbol at left means the power-cord plug must be unplugged from the outlet.

**⚠ Incorrect operation may cause injury.**

**⚠ WARNING**

**!** Be sure to follow the operation procedures described in this documentation. **Never allow anyone unfamiliar with the usage or handling of the machine to touch it.**

Incorrect usage or handling may lead to an accident.

**!** **Keep children away from the machine.** The machine includes areas and components that pose a hazard to children and may result in injury, blindness, choking, or other serious accident.

**⊘** **Never operate the machine while tired or after ingesting alcohol or any medication.** Operation requires unimpaired judgment. Impaired judgment may result in an accident.

**⊘** **Never use the machine for any purpose for which it is not intended, or use the machine in an undue manner that exceeds its capacity.** Doing so may result in injury or fire.

**!** **For accessories (optional and consumable items, power cord, and the like), use only genuine articles compatible with this machine.** Incompatible items may lead to an accident.

**!** **Before attempting cleaning, maintenance, or attachment or detachment of optional items, disconnect the power cord.** Attempting such operations while the machine is connected to a power source may result in injury or electrical shock.

**⊘** **Never attempt to disassemble, repair, or modify the machine.** Doing so may result in fire, electrical shock, or injury. Entrust repairs to a trained service technician.

**⚠ CAUTION**

**⚠** **Exercise caution to avoid being pinched or becoming caught.** Inadvertent contact with certain areas may cause the hand or fingers to be pinched or become caught. Use care when performing operations.

**⊘** **Never attempt operation while wearing a necktie, necklace, or loose clothing. Bind long hair securely.** Such items may become caught in the machine, resulting in injury.

**!** **Conduct operations in a clean, brightly lit location.** Working in a location that is dark or cluttered may lead to an accident, such as becoming caught in the machine as the result of an inadvertent stumble.

**⊘** **Never climb or lean on the machine.** The machine is not made to support a person. Climbing or leaning on the machine may dislodge components and cause a slip or fall, resulting in injury.

**⚠** **Caution: cutting tool** This machine has an internal tool. To avoid injury, handle the tool with care.

**⚠ Danger of electrical short, shock, electrocution, or fire**

**⚠ WARNING**



**Connect to an electrical outlet that complies with this machine's ratings (for voltage, frequency, and current).**  
Incorrect voltage or insufficient current may cause fire or electrical shock.

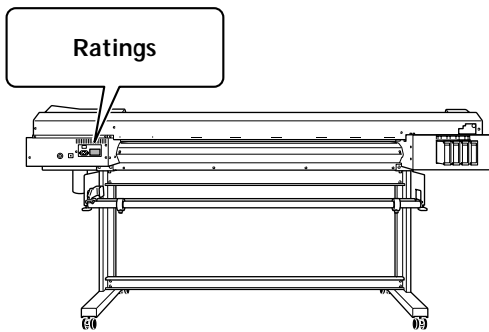

**Never use out of doors or in any location where exposure to water or high humidity may occur. Never touch with wet hands.**  
Doing so may result in fire or electrical shock.



**Never allow any foreign object to get inside. Never expose to liquid spills.**  
Inserting objects such as coins or matches or allowing beverages to be spilled into the ventilation ports may result in fire or electrical shock. If anything gets inside, immediately disconnect the power cord and contact your authorized Roland DG Corp. dealer.



**Never place any flammable object nearby. Never use a combustible aerosol spray nearby. Never use in any location where gases can accumulate.**  
Combustion or explosion may be a danger.



**Handle the power cord, plug, and electrical outlet correctly and with care. Never use any article that is damaged.**  
Using a damaged article may result in fire or electrical shock.



**When using an extension cord or power strip, use one that adequately satisfies the machine's ratings (for voltage, frequency, and current).**  
Use of multiple electrical loads on a single electrical outlet or of a lengthy extension cord may cause fire.

**⚠ WARNING**



**Connect to ground.**  
This can prevent fire or electrical shock due to current leakage in the event of malfunction.



**Position so that the power plug is within immediate reach at all times.**  
This is to enable quick disconnection of the power plug in the event of an emergency. Install the machine next to an electrical outlet. Also, provide enough empty space to allow immediate access to the electrical outlet.



**If sparking, smoke, burning odor, unusual sound, or abnormal operation occurs, immediately unplug the power cord. Never use if any component is damaged.**  
Continuing to use the machine may result in fire, electrical shock, or injury. Contact your authorized Roland DG Corp. dealer.

**⚠ Important notes about the power cord, plug, and electrical outlet**

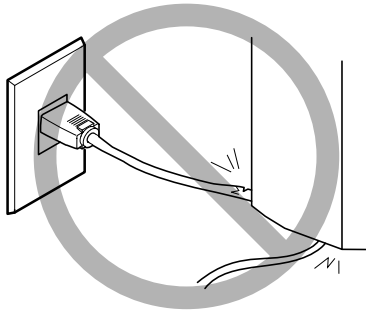

**Never place any object on top or subject to damage.**

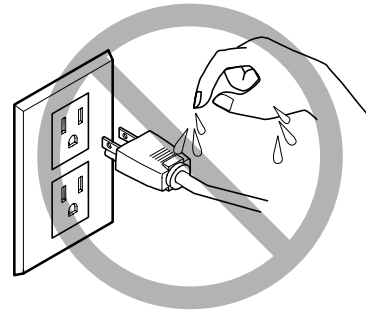

**Never allow to get wet.**

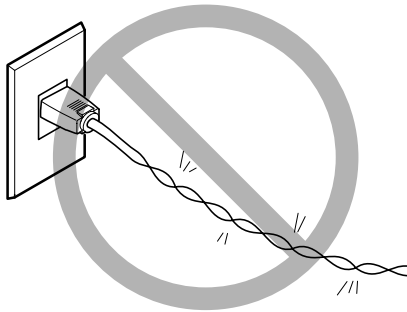

**Never bend or twist with undue force.**

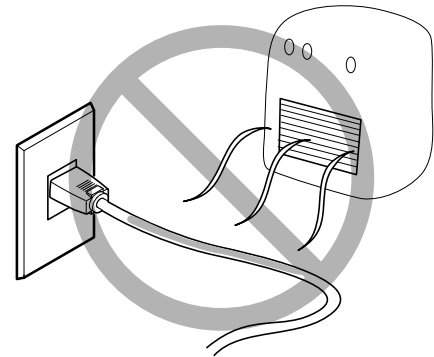

**Never make hot.**

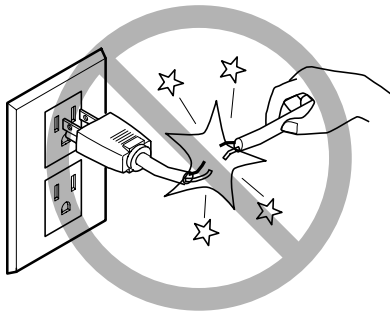

**Never pull with undue force.**

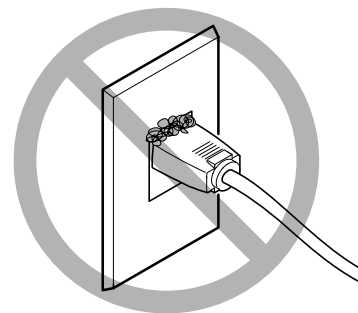

**Dust may cause fire.**

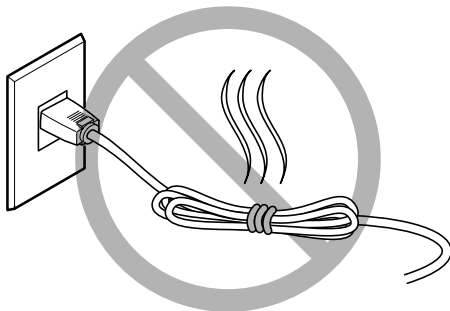



**Never bundle, bind, or roll up.**



 **Ink, cleaning fluid, and discharged fluid are flammable and toxic.**

 **WARNING**

 If you're using a model that uses ECO-SOL MAX ink, keep open flame away from the work area.  
Ink and discharged fluid are flammable.

 Never store ink, cleaning fluid, or discharged fluid in any of the following locations.

- Any location exposed to open flame
- Any location where high temperature may occur
- Near bleach or any other such oxidizing agent or explosive material
- Any location within the reach of children

Fire may be a danger. Accidental ingestion by children may pose a health hazard.

 Never place an ink cartridge in fire.  
Ink may flow out, catch fire, and spread fire to other nearby objects.

 Never drink or sniff ink, cleaning fluid, or discharged fluid, or allow them to come in contact with the eyes or skin.  
Doing so may be hazardous to the health.

 **CAUTION**

 Ensure adequate ventilation for the work area.  
Failing to perform ventilation may result in a health hazard or danger of combustion due to ink fumes.

 Never allow an ink cartridge to be subjected to impact, and never attempt to disassemble.  
Ink may leak.

---

 **In the event of ingestion or physical distress**

---

- In the event of contact with the eyes, immediately flush with water for at least 15 minutes. If eye irritation continues, seek treatment by a physician.
- In the event of contact with skin, immediately wash with soap. If irritation or inflammation occur, seek treatment by a physician.
- In the event of ingestion, do not induce vomiting, and immediately seek treatment by a physician. Forcibly inducing vomiting may lead to danger of choking.
- If odor leads to physical distress, move to a well-ventilated location and rest quietly. If dizziness or nausea persists, seek treatment by a physician.

 **This machine weighs 160 kg (353 lb.). Media weighs 30 kg (66 lb.).**

 **WARNING**

 **Install the machine in a location that is level, stable, and able to bear the weight of the machine.**

The total weight of the machine may reach 160 kg (353 lb.) or more (120 kg (265 lb.) or more for the 30-inch model). Installation in an unsuitable location may cause a major accident, including tipover, fall, or collapse.

 **Unloading and emplacement are operations that must be performed by six persons or more (by four persons or more for the 30-inch model).**

Tasks that require undue effort when performed by a small number of persons may result in physical injury. Also, if dropped, such items may cause injury.

 **WARNING**

 **Be sure to lock the stand's casters.**  
If the machine should begin to topple, a major accident may result, including crushing of the appendages or the body.

 **When storing roll media, implement adequate safety measures to ensure that the stored media will not roll, fall, or topple over.**

Danger exists of becoming pinned under the media and suffering serious injury.

 **Handling roll media is an operation that must be performed by two persons or more, and care must be taken to prevent falls.**

Attempting to lift heavy media in a manner that taxes your strength may cause physical injury.

 **Danger of fire, burns, or toxic gas emissions**

 **WARNING**

 **Caution: high temperatures**  
Areas such as the dryer become hot. Exercise caution to avoid fire or burns.

 **When printing is not being performed, remove any loaded media or switch off the power.**

The continued application of heat at a single location may cause the release of toxic gases from the media or pose a fire hazard.

 **WARNING**

 **Never use media that cannot withstand heat.**

Doing so may degrade the media, or may result in fire or the release of toxic gases.

## ⚠ Warning Labels

Warning labels are affixed to make areas of danger immediately clear. The meanings of these labels are as follows. Be sure to heed their warnings.

Also, never remove the labels or allow them to become obscured.

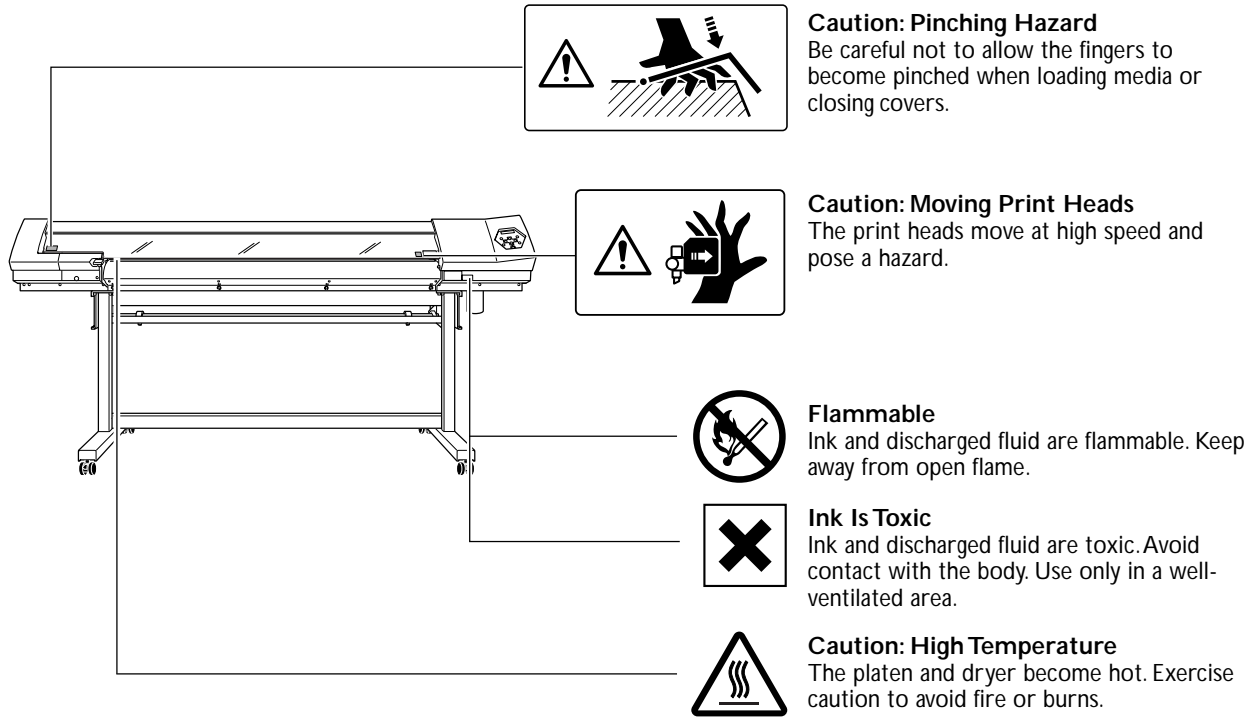

 **Flammable**  
Ink and discharged fluid are flammable. Keep away from open flame.

 **Ink Is Toxic**  
Ink and discharged fluid are toxic. Avoid contact with the body. Use only in a well-ventilated area.

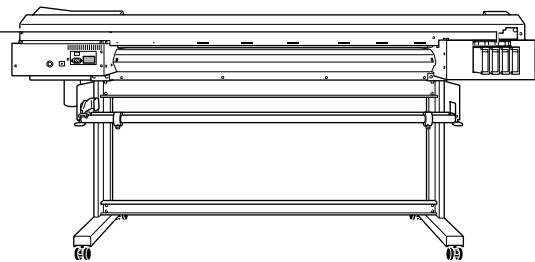







# Pour utiliser en toute sécurité

La manipulation ou l'utilisation inadéquates de cet appareil peuvent causer des blessures ou des dommages matériels. Les précautions à prendre pour prévenir les blessures ou les dommages sont décrites ci-dessous.

## Avis sur les avertissements

 <b>ATTENTION</b>	Utilisé pour avertir l'utilisateur d'un risque de décès ou de blessure grave en cas de mauvaise utilisation de l'appareil.
 <b>PRUDENCE</b>	Utilisé pour avertir l'utilisateur d'un risque de blessure ou de dommage matériel en cas de mauvaise utilisation de l'appareil. * Par dommage matériel, il est entendu dommage ou tout autre effet indésirable sur la maison, tous les meubles et même les animaux domestiques.

## À propos des symboles

	Le symbole $\triangle$ attire l'attention de l'utilisateur sur les instructions importantes ou les avertissements. Le sens précis du symbole est déterminé par le dessin à l'intérieur du triangle. Le symbole à gauche signifie "danger d'électrocution."
	Le symbole $\otimes$ avertit l'utilisateur de ce qu'il ne doit pas faire, ce qui est interdit. La chose spécifique à ne pas faire est indiquée par le dessin à l'intérieur du cercle. Le symbole à gauche signifie que l'appareil ne doit jamais être démonté.
	Le symbole $\bullet$ prévient l'utilisateur sur ce qu'il doit faire. La chose spécifique à faire est indiquée par le dessin à l'intérieur du cercle. Le symbole à gauche signifie que le fil électrique doit être débranché de la prise.

Ce document est le guide d'installation pour les appareils VP-540 et VP-300. Dans le document, les noms suivants sont utilisés pour établir la différence entre les deux modèles, lorsque c'est nécessaire.

VP-540 — Modèle de 54 po

VP-300 — Modèle de 30 po

## L'utilisation incorrecte peut causer des blessures

### ATTENTION

 **S'assurer de suivre les procédures d'utilisation décrites dans la documentation. Ne jamais permettre à quiconque ne connaît pas le fonctionnement ou la manutention de l'appareil de le toucher.**  
L'utilisation ou la manutention incorrectes peuvent causer un accident.

 **Garder les enfants loin de l'appareil.**  
L'appareil comporte des zones et des composants qui présentent un danger pour les enfants et qui pourraient causer des blessures, la cécité, la suffocation ou d'autres accidents graves.

 **Ne jamais faire fonctionner l'appareil après avoir consommé de l'alcool ou des médicaments, ou dans un état de fatigue.**  
L'utilisation de l'appareil exige un jugement sans faille. L'utilisation avec les facultés affaiblies pourrait entraîner un accident.

 **Ne jamais utiliser l'appareil à des fins autres que celles pour lesquelles il est conçu. Ne jamais l'utiliser de manière abusive ou d'une manière qui dépasse sa capacité.**  
Le non-respect de cette consigne peut causer des blessures ou un incendie.

 **Utiliser uniquement des accessoires d'origine (accessoires en option, articles consommables, câble d'alimentation et autres articles semblables), compatibles avec l'appareil.**  
Les articles incompatibles risquent de causer des accidents.

 **Débrancher le câble d'alimentation avant de procéder au nettoyage ou à l'entretien de l'appareil, et avant d'y fixer ou d'en retirer des accessoires en option.**  
Tenter ces opérations pendant que l'appareil est branché à une source d'alimentation peut causer des blessures ou un choc électrique.

 **Ne jamais tenter de démonter, de réparer ou de modifier l'appareil.**  
Le non-respect de cette consigne risque de provoquer un incendie, un choc électrique ou des blessures. Confier les réparations à un technicien ayant la formation requise.

### PRUDENCE

 **Faire preuve de prudence pour éviter l'écrasement ou le coincement.**  
La main ou les doigts peuvent être écrasés ou coincés s'ils entrent en contact avec certaines surfaces par inadvertance. Faire preuve de prudence pendant l'utilisation de l'appareil.

 **Ne jamais faire fonctionner l'appareil si on porte une cravate, un collier ou des vêtements amples. Bien attacher les cheveux longs.**  
Ces vêtements ou ces objets peuvent être coincés dans l'appareil, ce qui causerait des blessures.

 **Utiliser l'appareil dans un endroit propre et bien éclairé.**  
Travailler dans un endroit sombre ou encombré peut causer un accident; l'utilisateur risque, par exemple, de trébucher malencontreusement et d'être coincé par une partie de l'appareil.

 **Ne jamais grimper ni s'appuyer sur la machine.**  
La machine n'est pas conçue pour supporter le poids d'une personne. Grimper ou s'appuyer sur la machine peut déplacer des éléments et causer un faux pas ou une chute, ce qui causerait des blessures.

 **Attention : outil de coupe.**  
Cet appareil contient un outil interne. Pour éviter les blessures, manipuler l'outil avec soin.

## ⚠ Risque de décharge ou de choc électrique, d'électrocution ou d'incendie

### ⚠ ATTENTION



**Brancher à une prise électrique conforme aux caractéristiques de cet appareil (tension, fréquence et courant).**

Une tension incorrecte ou un courant insuffisant peuvent causer un incendie ou un choc électrique.

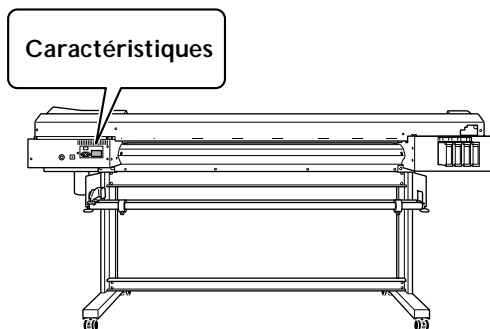

**Ne jamais utiliser à l'extérieur ni à un endroit où l'appareil risque d'être exposé à de l'eau ou à une humidité élevée. Ne jamais toucher l'appareil avec des mains mouillées.**

Le non-respect de cette consigne risque de provoquer un incendie ou un choc électrique.



**Ne jamais insérer d'objet étranger dans l'appareil. Ne jamais exposer l'appareil aux déversements de liquides.**

L'insertion d'objets comme des pièces de monnaie ou des allumettes, ou le déversement de liquides dans les orifices de ventilation peuvent causer un incendie ou un choc électrique. Si un objet ou du liquide s'infiltré dans l'appareil, débrancher immédiatement le câble d'alimentation et communiquer avec le représentant Roland DG Corp. autorisé.



**Ne jamais placer d'objet inflammable à proximité de l'appareil. Ne jamais utiliser de produit inflammable en aérosol à proximité de l'appareil. Ne jamais utiliser l'appareil dans un endroit où des gaz peuvent s'accumuler.**

Une combustion ou une explosion pourraient se produire.

### ⚠ ATTENTION



**Manipuler le câble d'alimentation, la fiche et la prise électrique correctement et avec soin.**

Ne jamais utiliser un article endommagé, car cela pourrait causer un incendie ou un choc électrique.



**Si une rallonge ou une bande d'alimentation électrique sont utilisées, s'assurer qu'elles correspondent aux caractéristiques de l'appareil (tension, fréquence et courant).**

L'utilisation de plusieurs charges électriques sur une prise unique ou une longue rallonge peut causer un incendie.



**Mise à la terre.**

La mise à la terre peut prévenir un incendie ou un choc électrique dus à une fuite de courant en cas de défaillance.



**Placer l'appareil de façon à ce que la fiche soit facile d'accès en tout temps.**

Ainsi, l'appareil pourra être débranché rapidement en cas d'urgence. Installer l'appareil près d'une prise électrique. En outre, prévoir suffisamment d'espace pour que la prise électrique soit facile d'accès.



**S'il se produit des étincelles, de la fumée, une odeur de brûlé, un bruit inhabituel ou un fonctionnement anormal, débrancher immédiatement le câble d'alimentation. Ne jamais utiliser si un composant est endommagé.**

Continuer à utiliser l'appareil peut causer un incendie, un choc électrique ou des blessures. Communiquer avec le représentant Roland DG Corp. Autorisé.

**⚠ Remarques importantes à propos du câble d'alimentation, de la fiche et de la prise électrique**

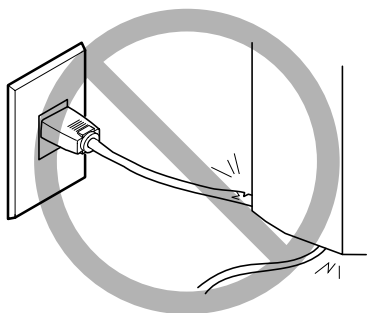

Ne jamais déposer aucun objet sur le câble, sur la fiche ou sur la prise car cela risque de les endommager.

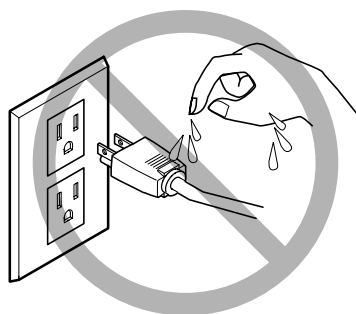

Ne jamais laisser l'eau toucher le câble, la fiche ou la prise.

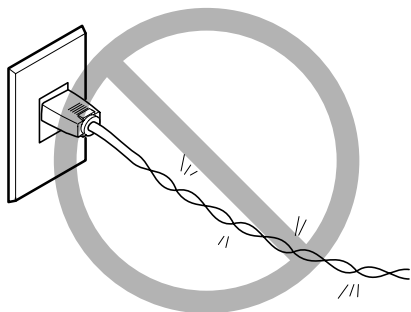

Ne jamais plier ni tordre le câble avec une force excessive.

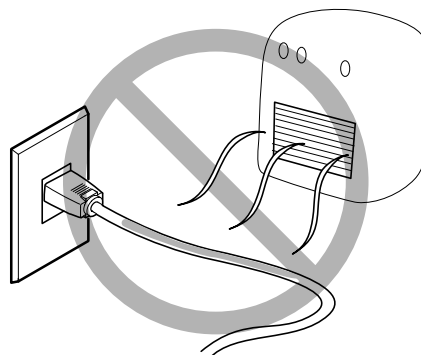

Ne jamais chauffer le câble, la fiche ou la prise.

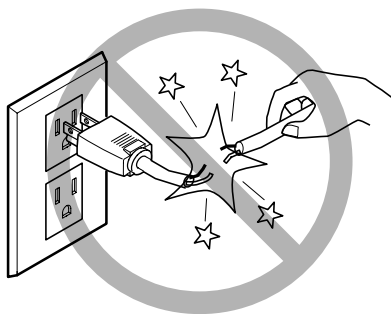

Ne jamais tirer sur le câble ou la fiche avec une force excessive.

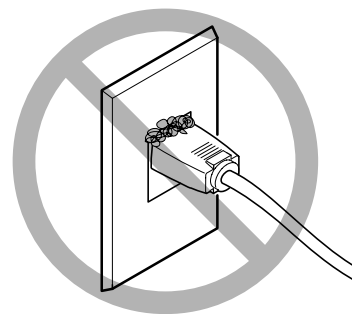

La poussière peut causer un incendie.

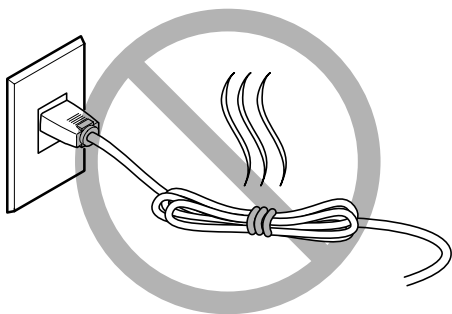

Ne jamais plier ni enrouler le câble.

**⚠ L'encre, les liquides nettoyants et les liquides usés sont inflammables et toxiques**

**⚠ ATTENTION**



S'il s'agit d'un modèle qui utilise l'encre ECO-SOL MAX, ne pas approcher une flamme nue de l'espace de travail.  
L'encre et les liquides usés sont inflammables.



Ne jamais entreposer d'encre, de liquide de nettoyage ou des liquides usés dans les endroits suivants :

- un endroit exposé à une flamme nue;
- un endroit où il y a risque de température élevée;
- près d'eau de Javel, d'un autre agent d'oxydation ou de matériel explosif;
- tout endroit à la portée d'enfants.

Il y a risque d'incendie. L'ingestion accidentelle par un enfant peut présenter un risque pour la santé.



Ne jamais incinérer une cartouche d'encre.  
De l'encre pourrait couler, s'enflammer et le feu se répandre à des objets proches.



Ne jamais boire l'encre, le liquide de nettoyage ni les liquides usés, ne pas en respirer les vapeurs et ne pas laisser les produits entrer en contact avec les yeux ou la peau.  
Cela est dangereux pour la santé.

**⚠ PRUDENCE**



S'assurer que le lieu de travail est bien aéré.  
L'absence d'aération adéquate peut créer une situation dangereuse pour la santé ou un risque de combustion à cause des vapeurs qui émanent de l'encre.



Ne jamais soumettre une cartouche d'encre à des chocs. Ne jamais tenter d'ouvrir une cartouche d'encre.  
De l'encre pourrait s'échapper.

**⚠ En cas d'ingestion ou de trouble physique**

- En cas de contact avec les yeux : rincer immédiatement et abondamment à l'eau courante pendant au moins 15 minutes. Si les yeux sont toujours irrités, consulter un médecin.
- En cas de contact avec la peau : laver immédiatement à l'eau et au savon. En cas d'irritation ou d'inflammation de la peau : consulter un médecin.
- En cas d'ingestion : ne pas provoquer le vomissement et demander immédiatement l'aide d'un médecin. Provoquer le vomissement peut créer un risque de suffocation.
- Si l'odeur cause un trouble physique, amener la personne dans un endroit bien aéré et la faire se reposer. Si l'étourdissement ou la nausée persistent, consulter un médecin.



 **Le poids de cet appareil est de 160 kg (353 lb.)  
Le poids du support est de 30 kg (66 lb.)**

### ATTENTION



**Installer l'appareil à un endroit stable et plat et capable de supporter son poids.**

Le poids total de l'appareil peut être de 160 kg (353 lb.) ou plus (120 kg (265 lb.) ou plus pour le modèle de 30 po). Installer l'appareil à un endroit inapproprié peut provoquer un accident grave comme le renversement, la chute ou l'écrasement.



**Le déchargement et la mise en place doivent être faits par au moins six personnes (quatre personnes ou plus pour le modèle de 30 po).**

Les tâches qui exigent un effort trop grand si elles sont exécutées par un petit nombre de personnes peuvent être cause de blessures. La chute d'articles très lourds peut aussi causer des blessures.

### ATTENTION



**S'assurer de verrouiller les roulettes de la base.**

Si l'appareil devait commencer à basculer, il s'ensuivrait un accident grave, par exemple l'écrasement de membres ou du corps.



**Prendre les mesures de sécurité adéquates pour l'entreposage des rouleaux de support pour s'assurer qu'ils ne rouleront pas, ne tomberont pas et ne se renverseront pas.**

Il y a risque d'être écrasé par le support et de subir des blessures graves.



**La manutention du support en rouleau doit être faite par deux personnes ou plus et il faut prendre des précautions pour éviter les chutes.**

Tenter de soulever des objets trop lourds peut causer des blessures.

 **Risque d'incendie, de brûlures ou d'émissions de gaz toxiques**

### ATTENTION



**Attention : températures élevées.**

Les zones comme le séchoir chauffent. Faire preuve de prudence pour éviter un incendie ou des brûlures.



**Quand aucun travail d'impression n'est en cours, retirer tout support de l'appareil ou couper l'alimentation électrique.**

L'application continue de chaleur à un point unique peut causer l'émission de gaz toxiques ou créer un risque d'incendie.

### ATTENTION



**Ne jamais utiliser un support qui ne peut pas supporter la chaleur.**

L'utilisation d'un support qui ne supporte pas la chaleur peut détériorer le support, créer un risque d'incendie ou causer l'émission de gaz toxiques.

## ⚠ Vignettes d'avertissement

Des vignettes d'avertissement sont apposées pour qu'il soit facile de repérer les zones dangereuses. La signification des vignettes est donnée ci-dessous. Respecter les avertissements. Ne jamais retirer les vignettes et ne pas les laisser s'encrasser.

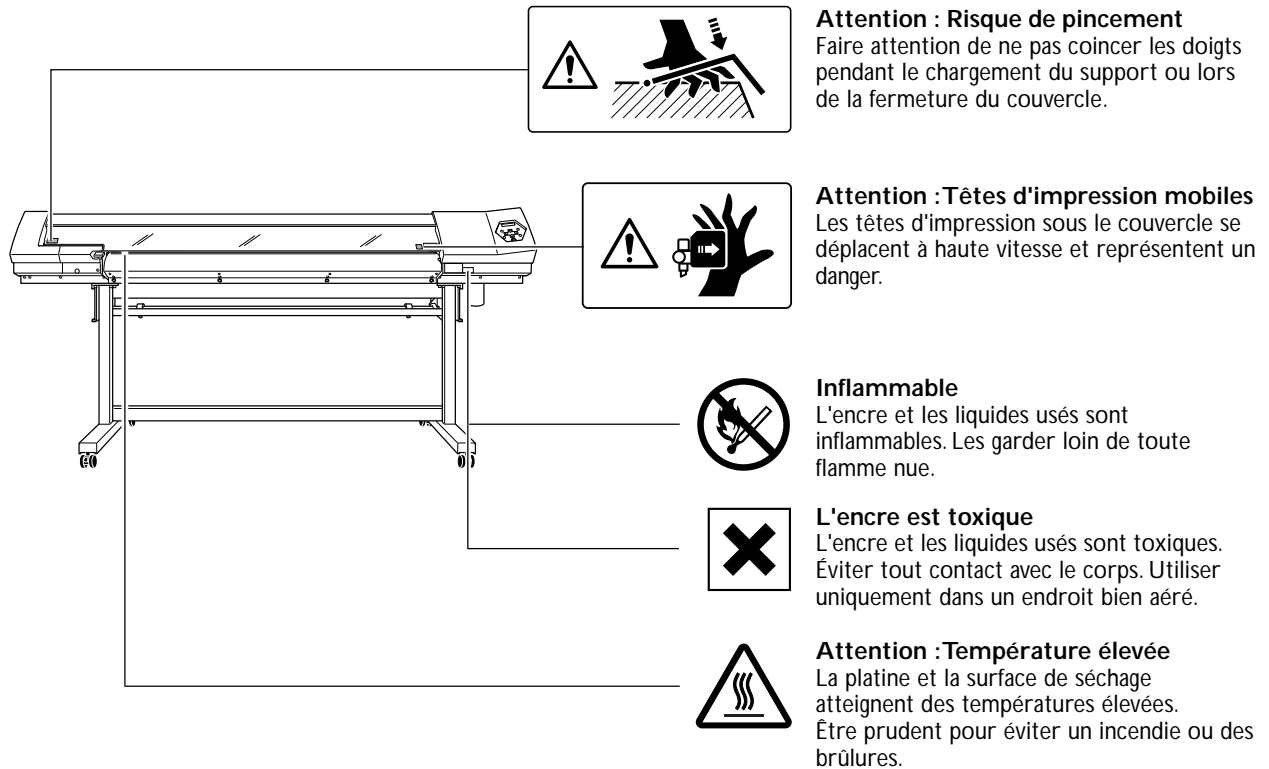

**Inflammable**

L'encre et les liquides usés sont inflammables. Les garder loin de toute flamme nue.



**L'encre est toxique**

L'encre et les liquides usés sont toxiques. Éviter tout contact avec le corps. Utiliser uniquement dans un endroit bien aéré.

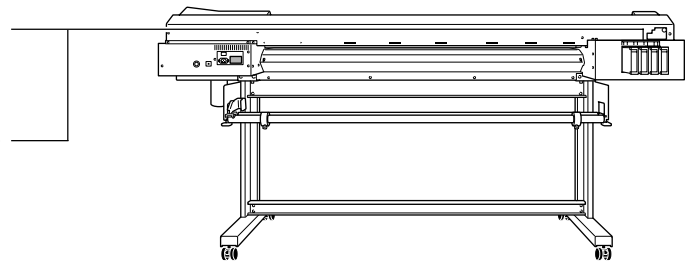



# *Setup Guide*

---

# 1. Included Items

The following items are packed together with the unit. Make sure they are all present and accounted for.

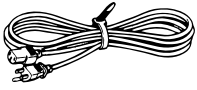

Power cord: 1

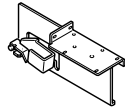

Arm (right): 1

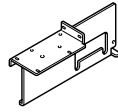

Arm (left): 1

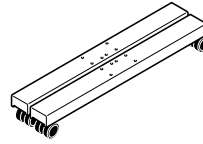

Casters: 2

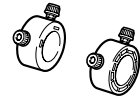

Stoppers: 2

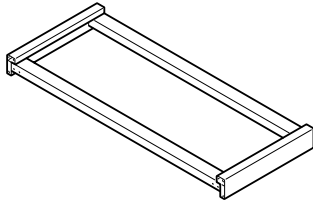

Stand leg: 1

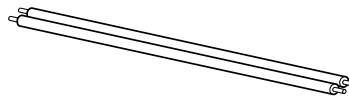

Shafts: 2

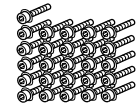

Bolts : 26



Hexagonal wrench: 1



Pipe: 1

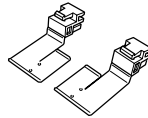

Short media clamps : 2  
(left and right) (\*1)

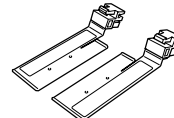

Long media clamps : 2  
(left and right)

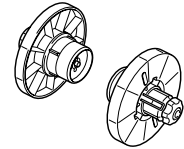

Media flanges: 2

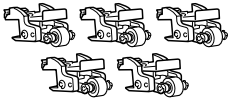

Middle pinch rollers:  
5 (54-inch model)  
2 (30-inch model) (\*2)



Blade: 1

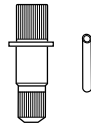

Blade holder: 1  
Pin:1

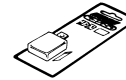

Replacement blade for  
separating knife: 1



Drain bottles: 2

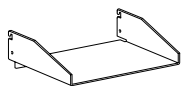

Ink-cartridge tray: 1

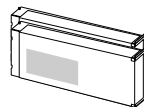

SOL INK cleaning  
cartridges: 2

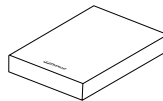

Software RIP: 1 set

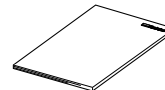

User's Manual: 1

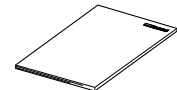

Setup Guide: 1  
(this document)

## Cleaning kit



Cleaning sticks: 10



Tweezers: 1

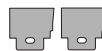

Replacement  
wipers: 2

\*1 The short media clamps are installed on the machine.

\*2 All the middle pinch rollers are installed on the machine.

## 2. Installation Environment

### Deciding On an Installation Site

Install in a quiet, stable location offering good operating conditions. An unsuitable location can cause accident, fire, faulty operation, or breakdown.

- ⚠️WARNING** **Install the machine in a location that is level, stable, and able to bear the weight of the machine.**  
The total weight of the machine may reach 160 kg (353 lb.) or more (120 kg (265 lb.) or more for the 30-inch model). Installation in an unsuitable location may cause a major accident, including tipover, fall, or collapse.
- ⚠️WARNING** **Never install out of doors or in any location where exposure to water or high humidity may occur.**  
Current leakage may cause electrical shock, electrocution, or combustion and fire.
- ⚠️WARNING** **Never install close to any flammable object or in a gas-filled location.**  
Combustion or explosion may be a danger.
- ⚠️WARNING** **Install in a clean, brightly lit location.**  
Working in a location that is dark or cluttered may lead to an accident, such as becoming caught in the machine as the result of an inadvertent stumble.
- ⚠️WARNING** **Position so that the power plug is within immediate reach at all times.**  
This is to enable quick disconnection of the power plug in the event of an emergency. Install the machine next to an electrical outlet. Also, provide enough empty space to allow immediate access to the electrical outlet.
- ⚠️CAUTION** **Ensure adequate ventilation for the work area.**  
Failing to perform ventilation may result in a health hazard or danger of combustion due to ink fumes.

#### Unsuitable Installation Sites

- Locations subject to large fluctuations in temperature or humidity
- Locations subject to shaking or vibration
- Locations where the floor is tilted, not level, or unstable
- Dusty locations
- Locations exposed to direct sunlight or near air-conditioning or heating equipment
- Locations exposed to water or moving air
- Locations exposed to considerable electrical or magnetic noise, or other forms of electromagnetic energy

## Temperature and Humidity

Maintain the specified temperature and humidity even when the machine is not in use. Temperatures that are too high may degrade the ink and cause malfunction. Temperatures that are too low may cause the ink to freeze and damage the heads.

During operation: Temperature 20 to 32°C (68 to 90°F), relative humidity 35 to 80% (no condensation)

During non-operation: Temperature 5 to 40°C (41 to 104°F), relative humidity 20 to 80% (no condensation)

## Installation Space

The space shown in the figure is required in order to use this machine.

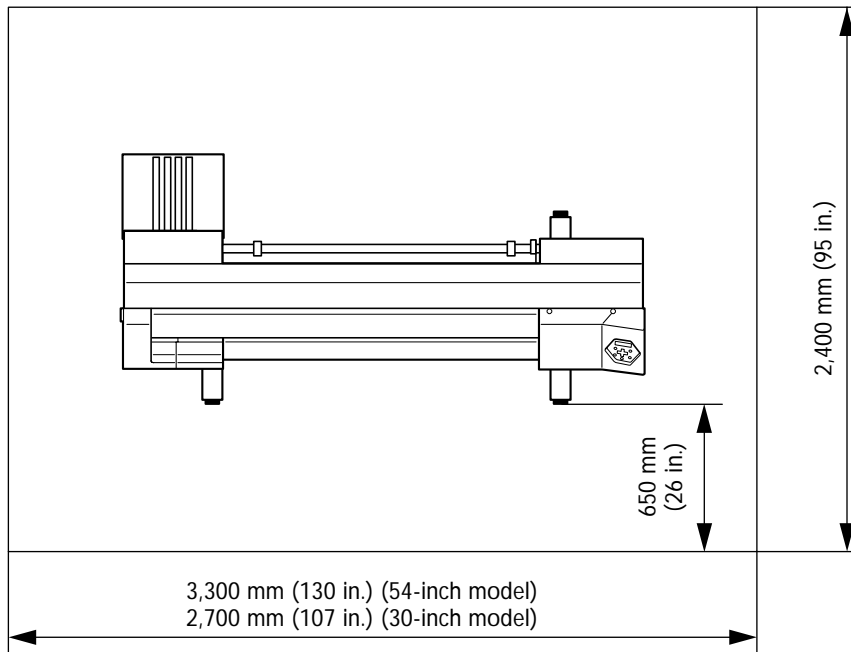

# 3. Assembling and Installing

## Assembling the Stand

First assemble the stand, then mount the machine on top of the stand.

**⚠ CAUTION** Unpacking and installation must be carried out by six persons or more (by four persons or more for the 30-inch model). Otherwise the machine or the stand may fall, resulting in injury.

### Procedure

**1** Attach the casters onto the stand leg.

The stand leg has no particular up or down orientation. Tighten the bolts securely. Loose bolts may cause the stand to wobble.

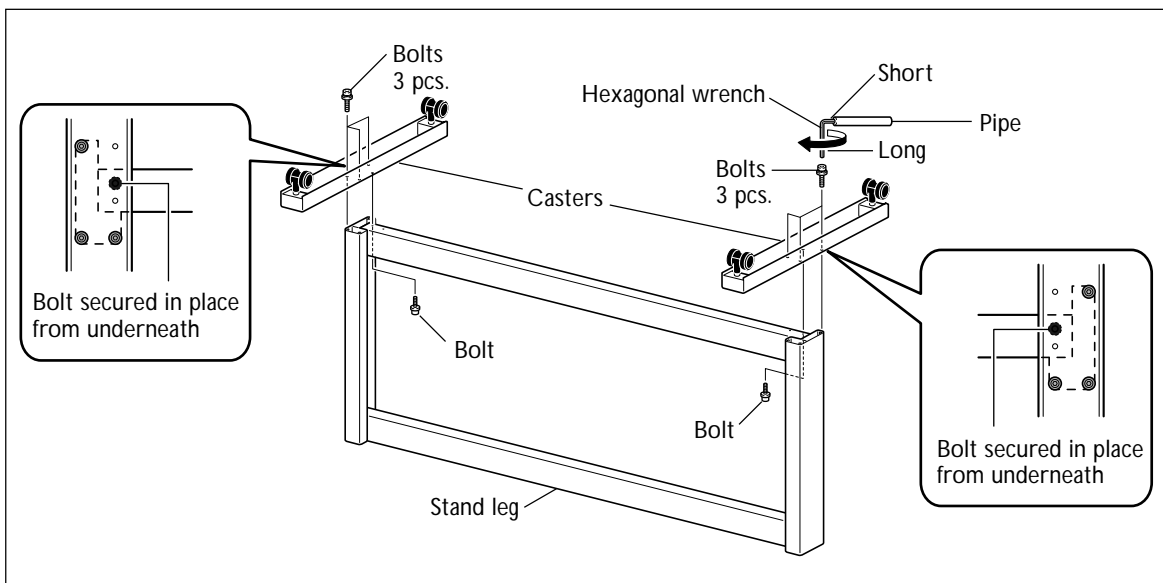

**2** Set the stand upright and attach the arms.

Be sure to attach first the lower bolts **1**, and then the upper bolts **2**. Attaching the upper bolts first may make it impossible to attach the lower bolts.

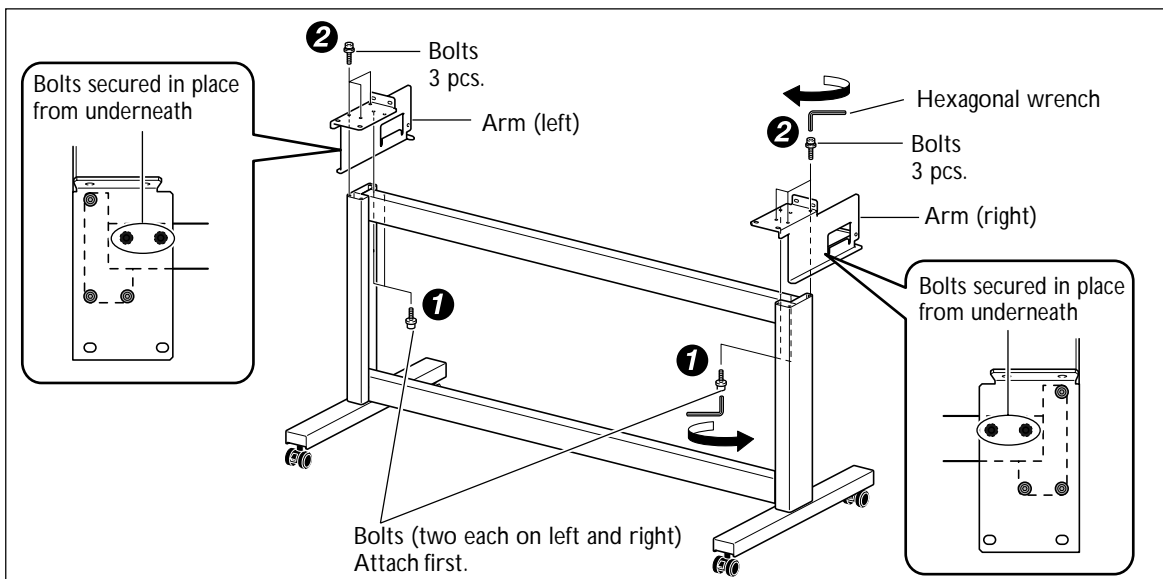



### 3. Assembling and Installing

- ③ Place the machine on the stand and secure it in place.  
Tighten the bolts securely. Loose bolts may cause the stand to wobble.

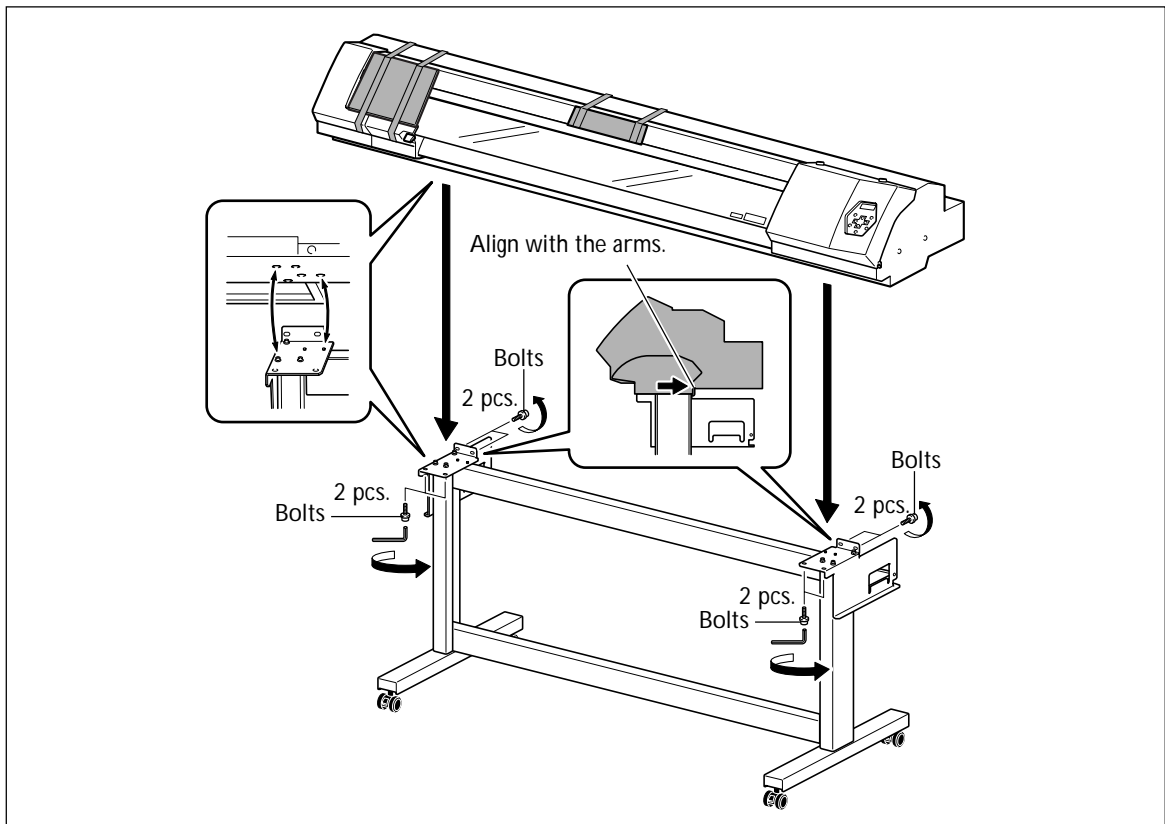

## Installing the Shafts

### Procedure

- 1 Fit the stoppers onto the shafts.

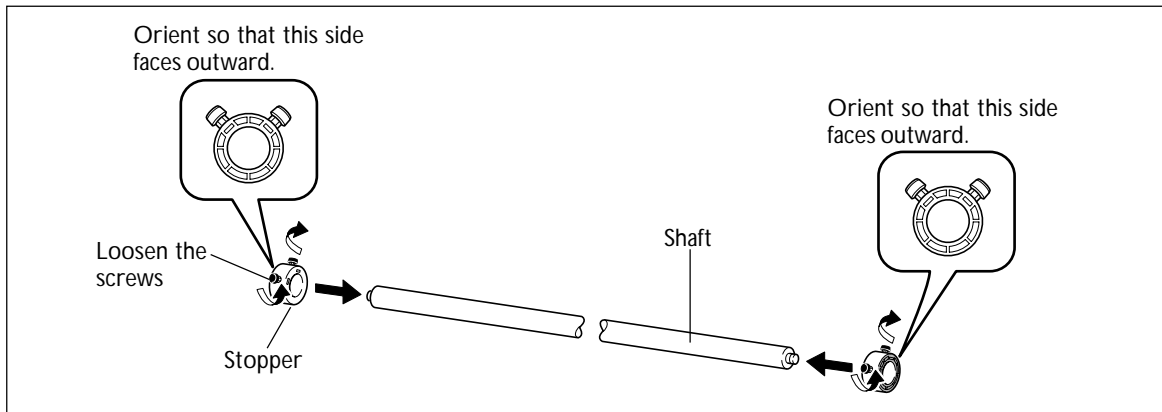

- 2 Install the two shafts to the arms.

Install the stopper-attached shaft at the location closest to the back of the machine (the location farthest from the front of the machine).

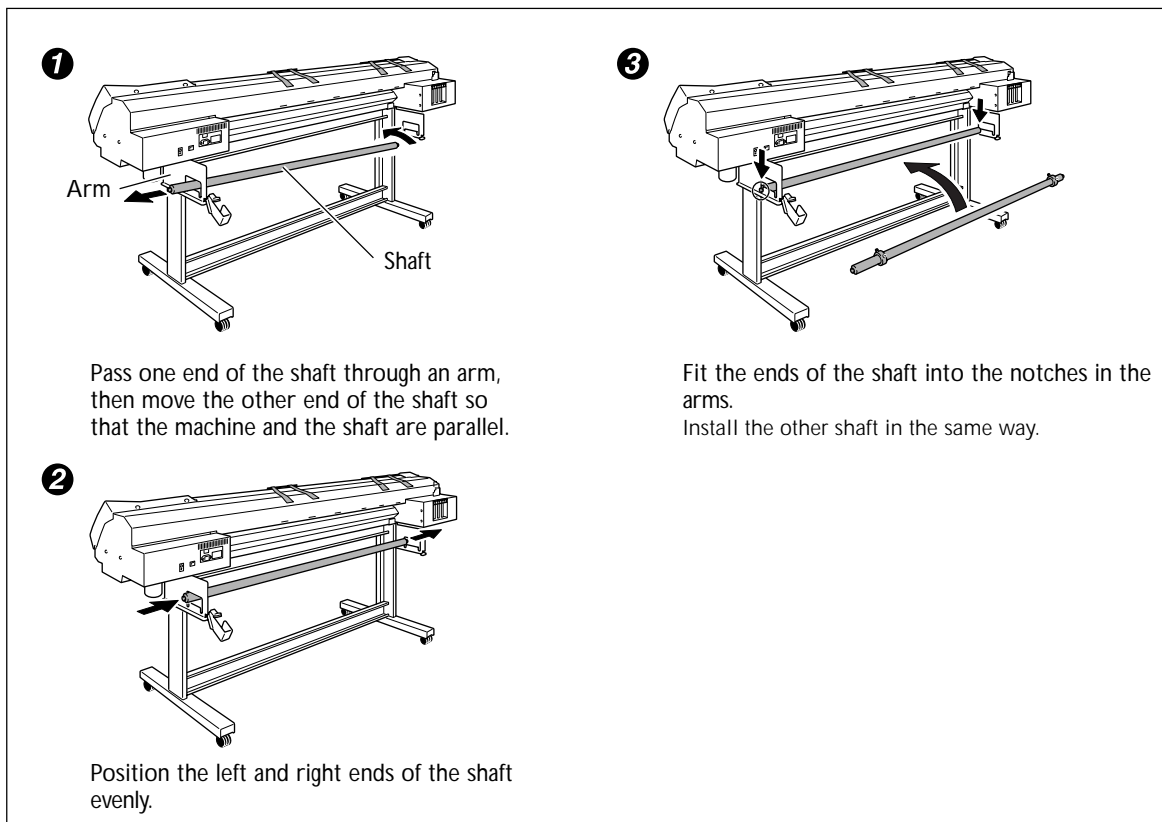

### 3. Assembling and Installing

---

③ Engage the brake.

Using the machine with the brake disengaged may result in unstable media feed.

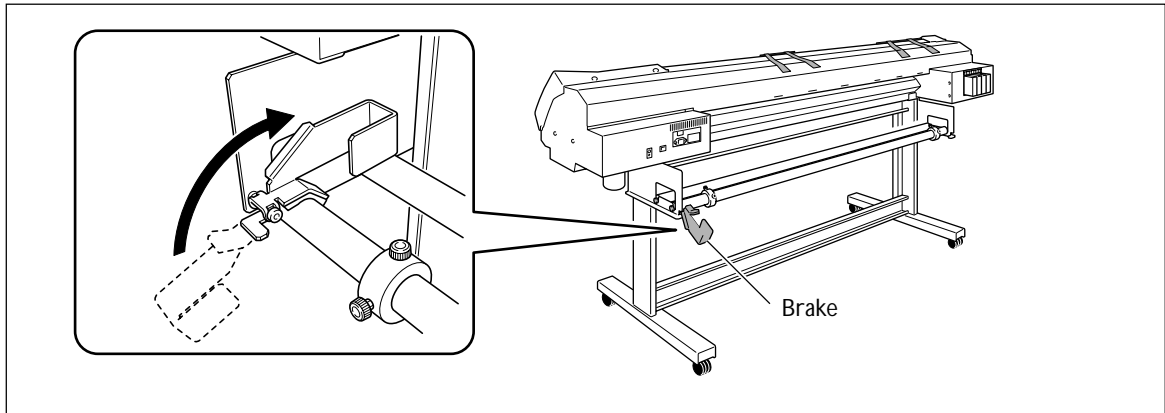

## Installing the Drain Bottle

**1** Remove the bottom plug.

Use caution, because discharged fluid used in inspection may remain.

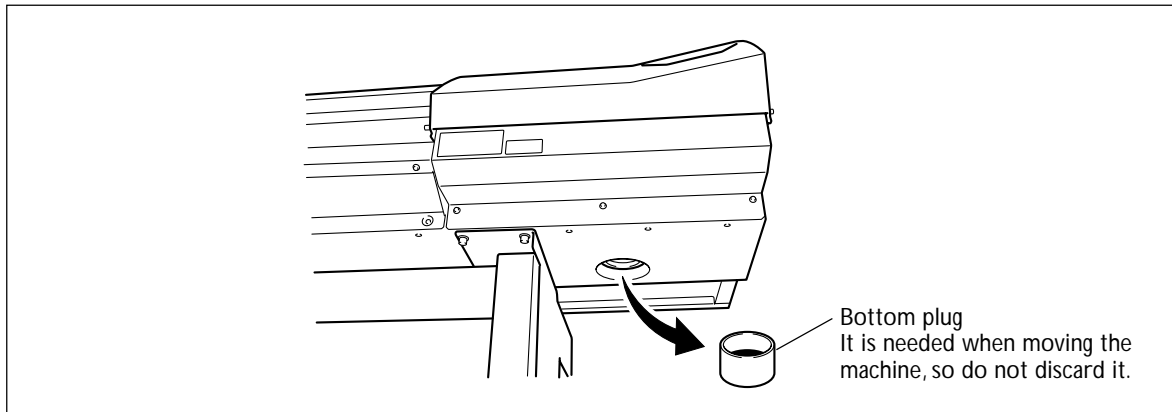

**2** Install the drain bottle.

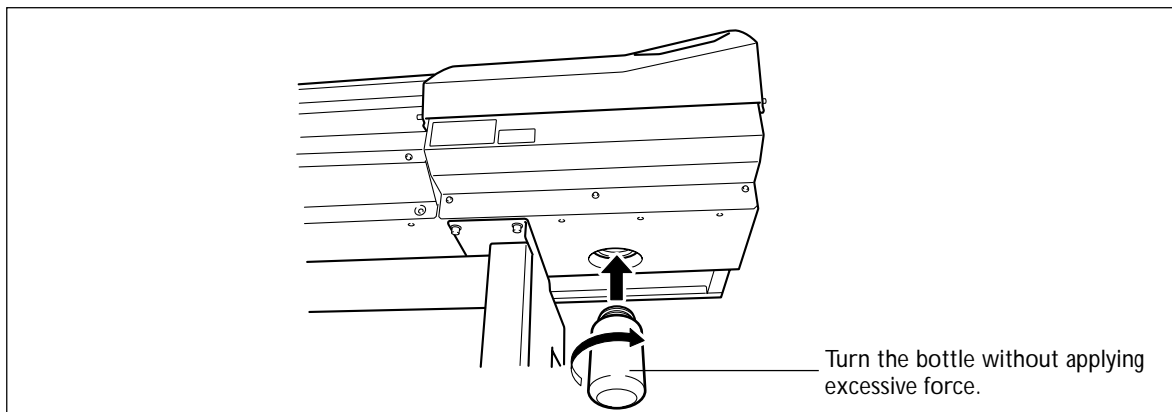

***Leave the drain bottle attached at all times.***

Remove it only when moving the machine or disposing of collected ink.

## Attaching the Ink-cartridge Tray

Attaching the ink-cartridge tray makes it possible to use 440-cc ink cartridges. Attach it as required.

### Procedure

- 1 Loosen the upper bolts. Remove the lower bolts.

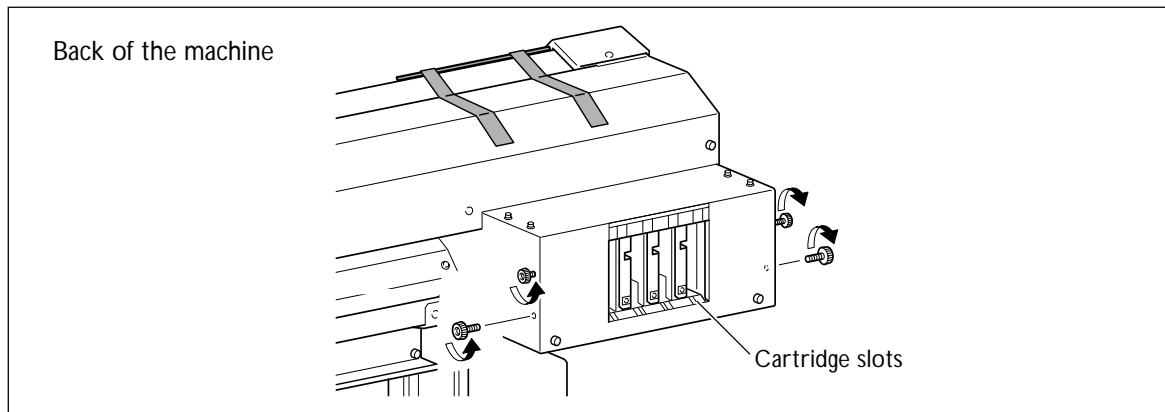

- 2 Mount the ink-cartridge tray on the upper bolts.

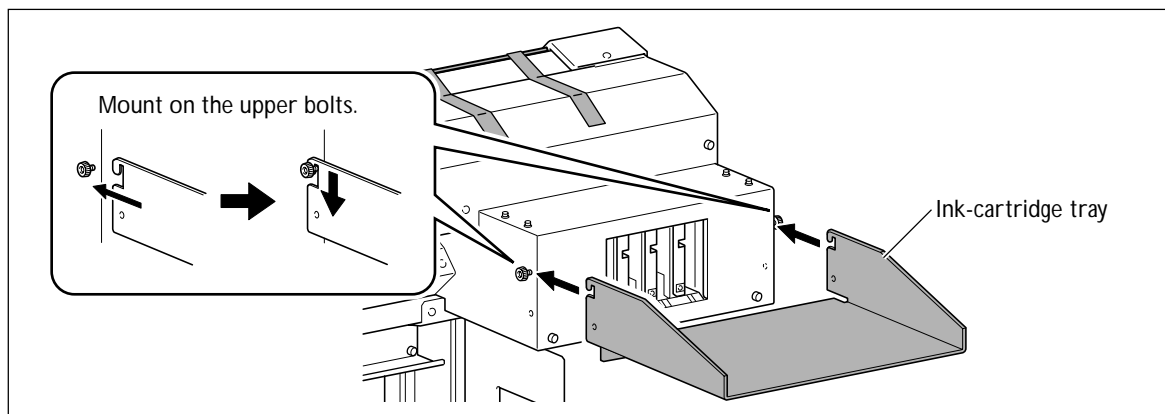

- 3 Secure the ink-cartridge tray in place with the four bolts (two upper and two lower).

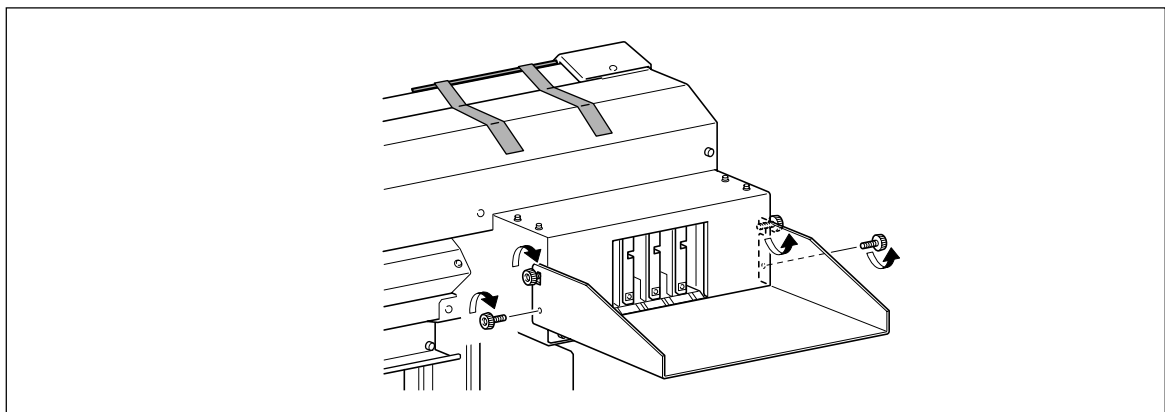

## Removing the Packing Materials

Tape and packing materials are attached to the machine to protect it from vibration during transportation. When installation is complete, remove these.

- Remove all packing materials. Any that remain may cause faulty operation or breakdown when the power is switched on.
- Store the packing materials carefully, because they are needed again when transporting the machine for relocation or the like.

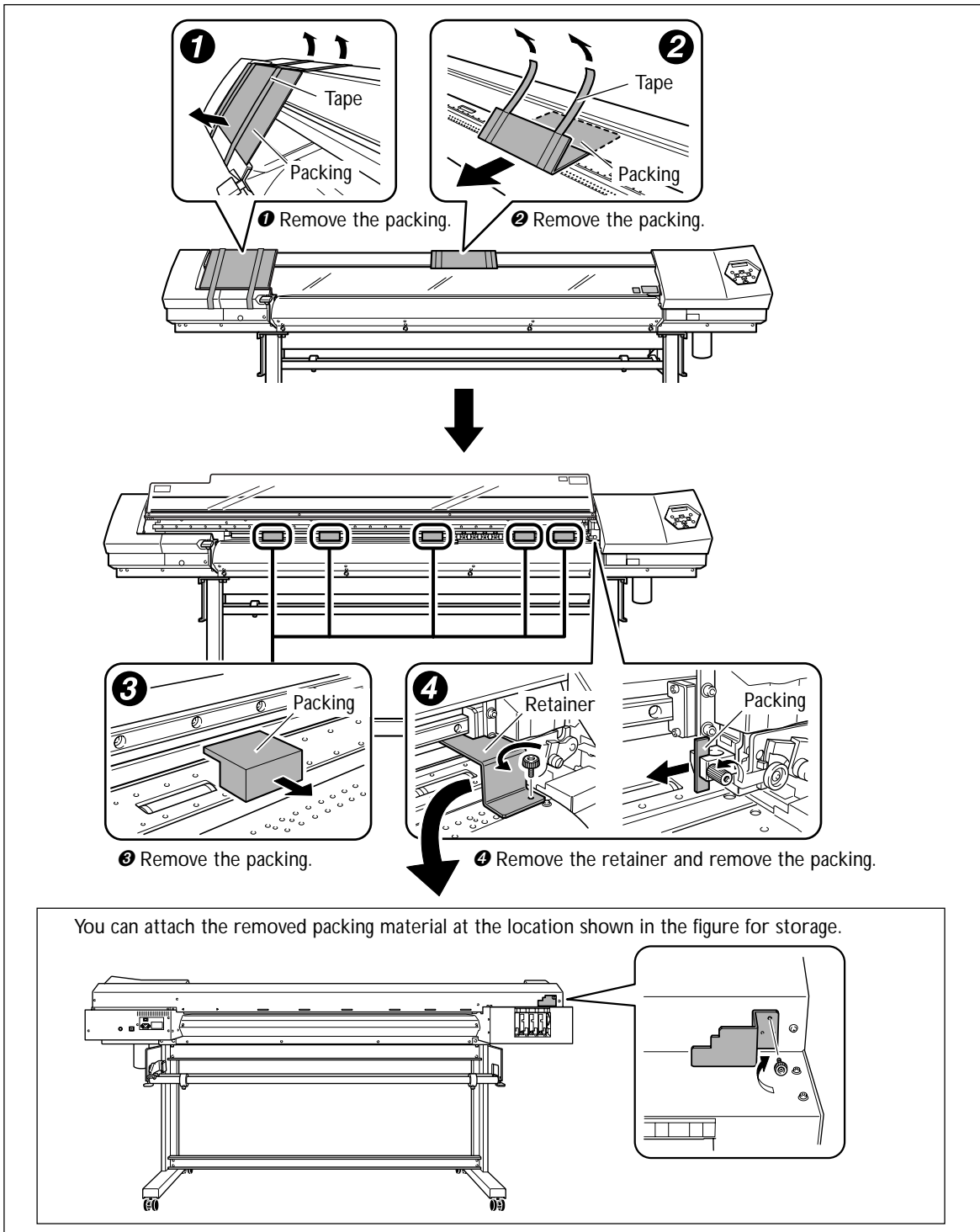

# 4. Connect the Cables

## Connecting the Cables

- ⚠️ WARNING** Connect to electrical outlet that complies with this machine's ratings (for voltage, frequency, and current).  
Incorrect voltage or insufficient current may cause fire or electrical shock.
- ⚠️ WARNING** Connect to ground.  
This can prevent fire or electrical shock due to current leakage in the event of malfunction.
- ⚠️ WARNING** Perform this task with all power switches left switched off.  
Otherwise sudden movement of the machine may cause injury.

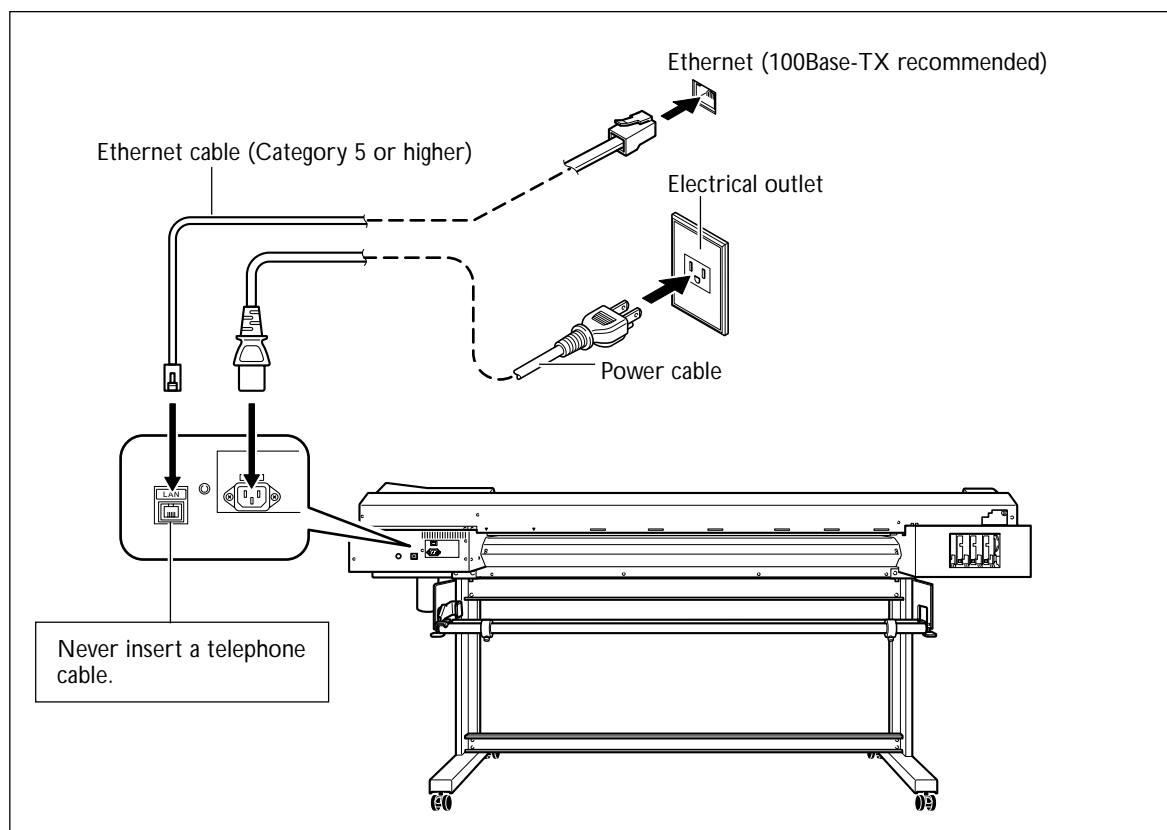

# 5. Installing the Ink Cartridges

## Filling with Ink for the First Time

Special procedures are required when installing ink cartridges for the first time. These are required only once, when installing ink cartridges for the first time after shipment from the factory.

You first clean the print heads using cleaning fluid, then fill with the inks of the various colors. This operation requires two SOL INK cleaning cartridges.

Never under any circumstances use anything other than the specified type of ink or cleaning fluid.

## Installing the Ink Cartridges

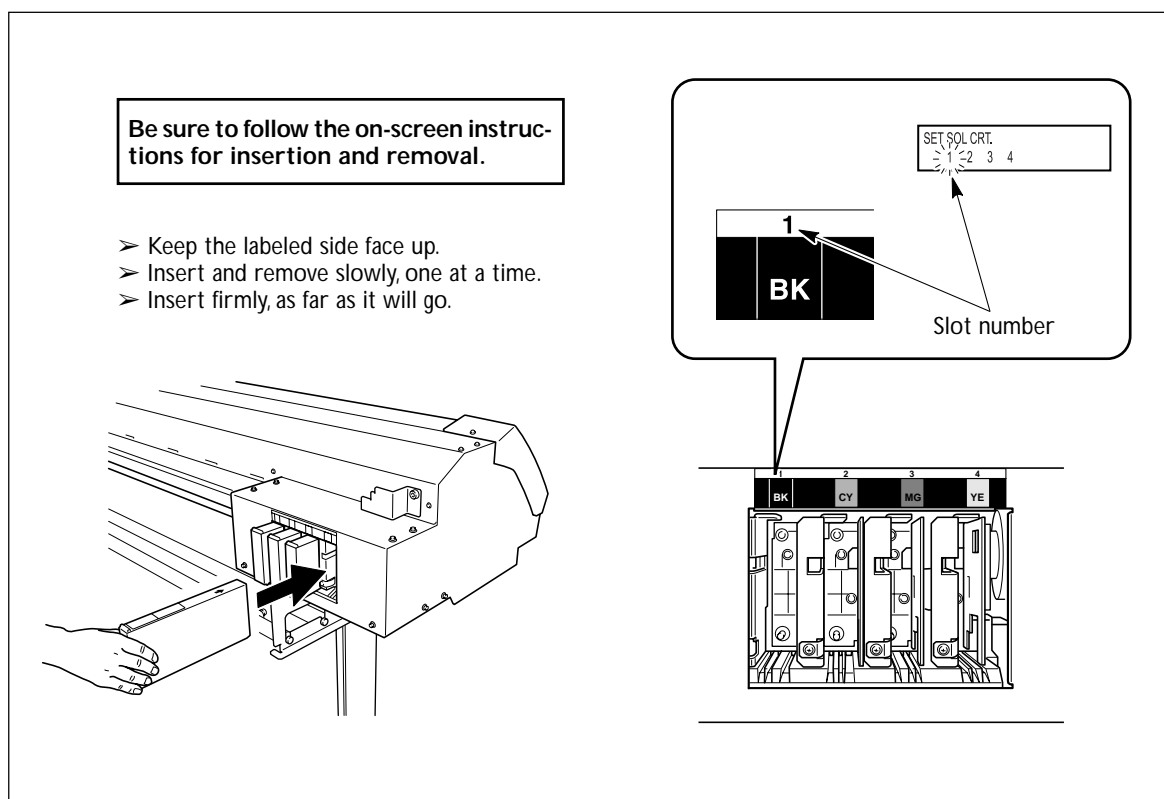

During cleaning, you insert and remove cartridges several times. The on-screen messages indicate which to insert and remove, and when to insert and remove them.

Insert each color ink cartridge into the slot labeled with the matching color. The cleaning cartridges are not differentiated by color.

### **⚠ CAUTION**

**Never insert your hand or fingers into the opening of the front cover.**  
The print heads move at high speed inside the cover. Contact may cause injury.



**1.** Switch on the power and make the initial settings.

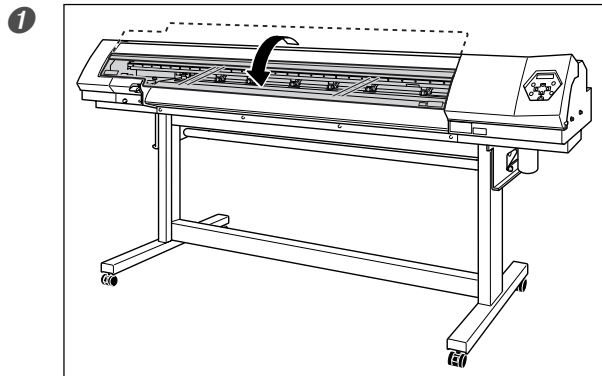

Close the front cover.

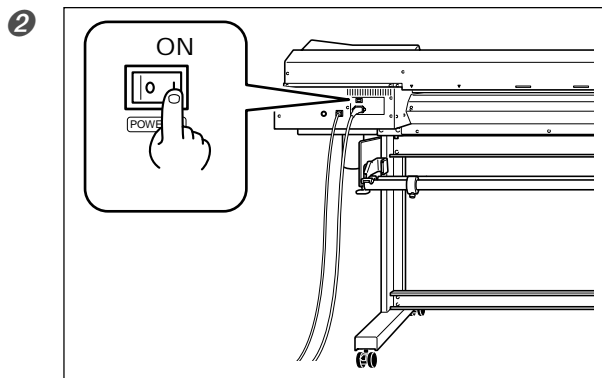

Switch on the main power switch.

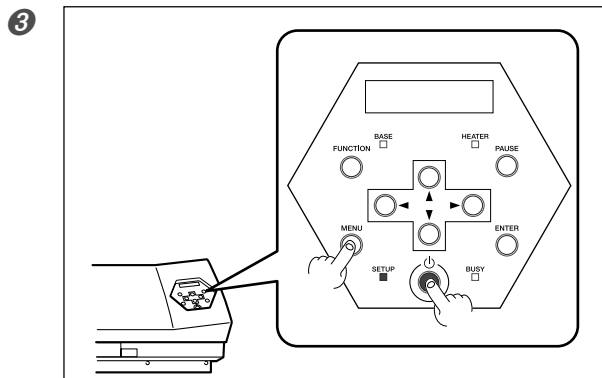

Hold down **MENU** and press the sub power switch.

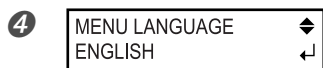

Use **▲** **▼** to select the language you want.  
Press **ENTER**.



Use **▲** **▼** to select the unit of measurement you want (for length).  
Press **ENTER**.



Use **▲** **▼** to select the unit of measurement you want (for temperature).  
Press **ENTER**.

## 2. Clean the heads using the cleaning cartridges.

① SELECT INK TYPE  
E-SOL Max 4 COLOR ↵

Make sure the ink type matches the ink cartridges.

Press **ENTER**.

② INSTALL  
DRAIN BOTTLE ↵

Make sure the drain bottle is installed.

Press **ENTER**.

③ SET SOL-CL LIQUID  
1 2

Flashing ↓

FILLING INK...  
>>>>

Insert cleaning cartridges into slots 1 and 2.

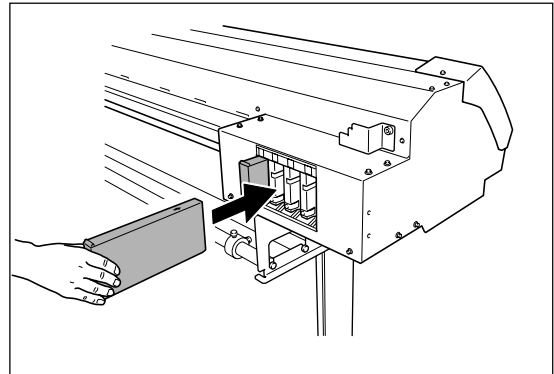

④ REMOVE SOL CL  
1 2

Flashing ↓

SET SOL-CL LIQUID  
3 4

Flashing ↓

FILLING INK...  
>>>>

Insert the cleaning cartridges you pulled out into slots 3 and 4.

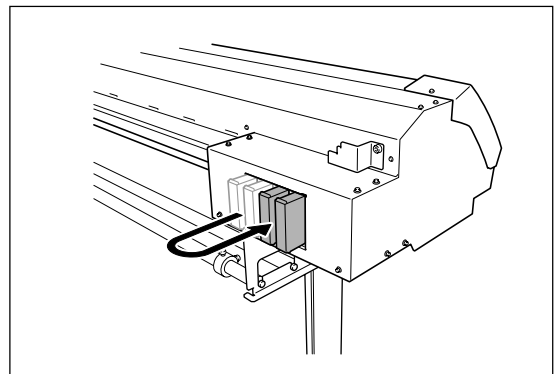

⑤ REMOVE SOL CL  
3 4

Flashing ↓

FILLING INK...  
>>>>

Pull out the cleaning cartridges.

⑥ CHECK  
DRAIN BOTTLE ↵

When this screen appears, cleaning is finished. Make sure the drain bottle is not overflowing with discharged fluid, then press **ENTER**.

### 3. Insert the ink cartridges for the respective colors.

1

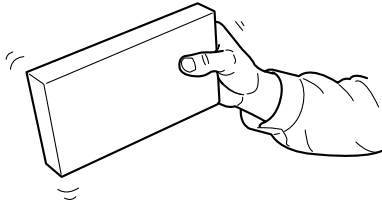

Before you insert the ink cartridge for each color, gently shake the cartridge.

2

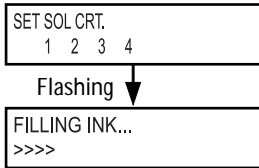

Insert the ink cartridge for each color.

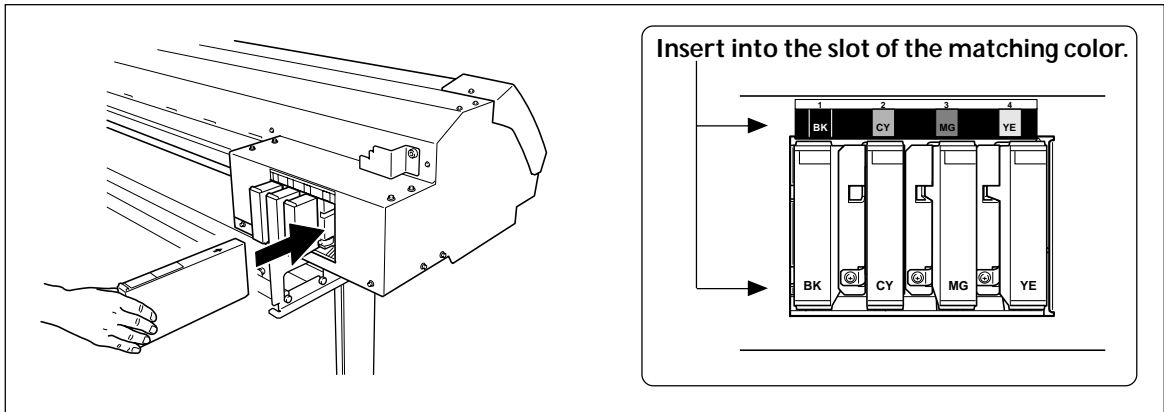

3

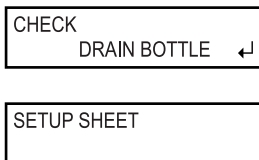

Make sure the drain bottle is not overflowing with discharged fluid, then press **ENTER**.

When this screen appears, filling with ink is finished.

# 6. Installing the Blade

**⚠ CAUTION** Be sure to perform operations as specified by these instructions, and never touch any area not specified in the instructions. Sudden movement of the machine may cause injury.

**⚠ CAUTION** Never touch the tip of the blade with your fingers. Doing so may result in injury, and the cutting performance of the blade will be impaired.

## 1. Insert a blade into the blade holder.

1

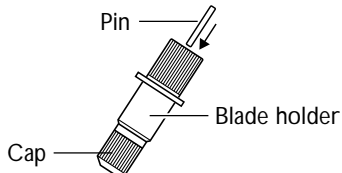

Insert the pin.

2

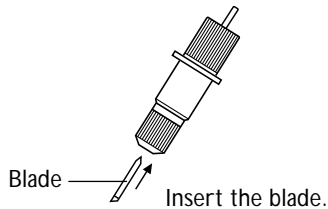

Insert the blade.

## 2. Enter the blade replacement mode.

1

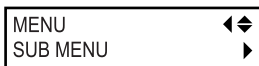

Press **MENU**.  
Press **▼** several times.

2



Press **▶**.  
Press **▲**.

3



Press **▶**.  
Press **▼** twice.

4

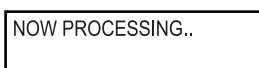

Press **ENTER**.



The cutting carriage moves to a location permitting blade replacement.

5

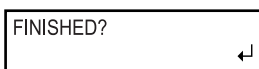

Open the front cover.  
Preparations are complete, when this screen appears.

### 3. Install the blade holder.

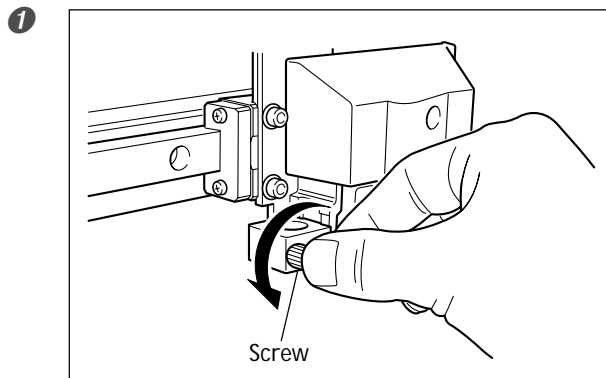

Loosen the screw shown in the figure.

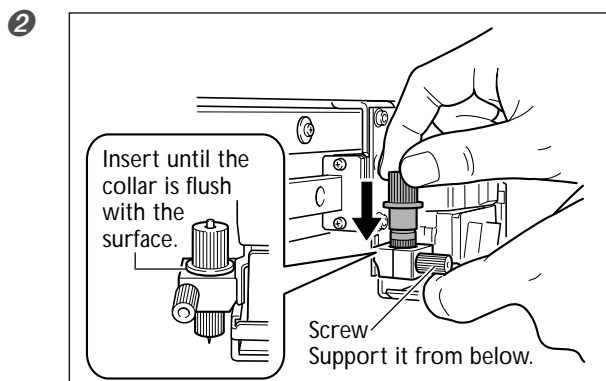

Support the screw from below and insert the blade holder.

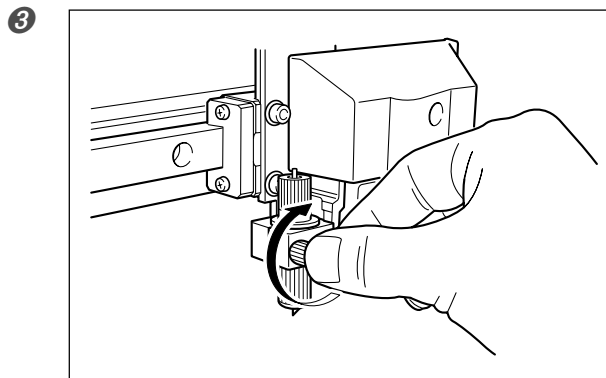

Tighten the screw.  
Tug the blade holder upward to make sure it does not come loose.

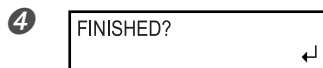

Close the front cover, then press **ENTER**.

#### ***Important Note on the Handling and Use of the Cutting Carriage***

Leave the cutting-carriage screw loose when no blade holder is installed. Keeping the screw tightened causes the blade-holder insertion hole to become gradually smaller, making installation difficult.

# 7. Network Settings

## Introduction

This machine has a built-in print server as a network interface. When you use the print server, you can send output data to the machine from anywhere on the network. TCP/IP is used as the protocol. Make sure the machine is connected to the network by an Ethernet cable.

The network settings on the machine must be made manually, using the operation panel. For information about how to make the settings, refer to "Step 2: Make the Network Settings on the Printer" later in this chapter.

Also, to perform output from this machine, the software raster image processor (RIP) included with the machine must be installed and set up. For information about installation and setup, refer to the documentation for the software RIP.

### Important

The examples used in the procedures for making the settings described in this section assume you are using one computer and one machine. The procedures and setting values described here may not be suitable for all operating environments.

If the computer you're using is connected to a number of networked devices or to the Internet, incorrect settings may adversely affect the entire network. For detailed information about the settings, consult your network administrator.

Also, the addresses used in this section are merely example settings.

## Step 1: Make the Network Settings for the Computer

### Procedure

- 1 Log on to Windows as a member of the "Administrators" group.
- 2 For Windows XP:  
From the [Start] menu, click [Control Panel]. Click [Network and Internet Connections], then click [Network Connections].  
For Windows 2000:  
From the [Start] menu, click [Settings], then click [Network and Dial-up Connections].

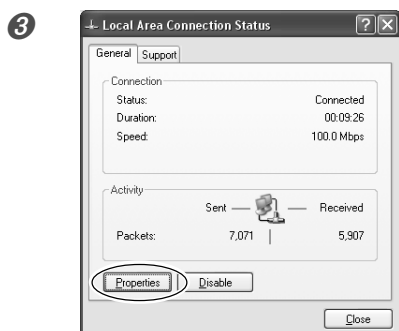

Double-click the [Local Area Connections] icon, then click [Properties].

## 7. Network Settings

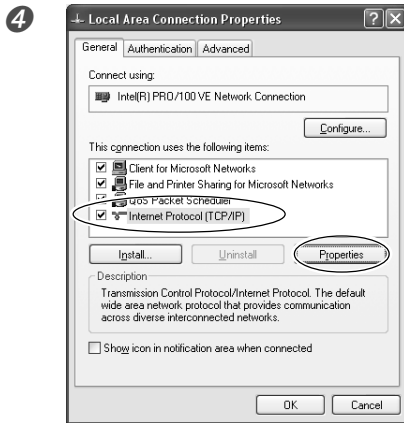

Select [Internet Protocol (TCP/IP)], then click [Properties]. If the check box for [Internet Protocol (TCP/IP)] is unselected, then click the check box to select it.

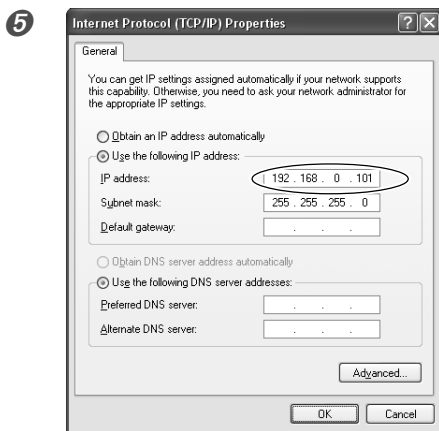

Select [Use the following IP address]. Enter the information as shown below, then click [OK].

[IP Address]: 192.168.0.XXX

[Subnet Mask]: 255.255.255.0

Note: Here, "XXX" may be any number you want from 1 to 254. However, be sure to specify a number that does not duplicate a number used for another computer or device. Here, by way of example, "192.168.0.101" is entered for the IP address and "255.255.255.0" for the subnet mask.

6 Close the [Local Area Connections] window.

## Step 2: Make the Network Settings on the Printer

### Important

The addresses used in this section are merely example settings. For detailed information about the settings, consult your network administrator.

### 1. Set the IP address.



Press .  
Press  several times.

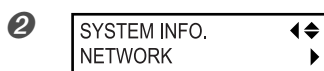

Press .  
Press .

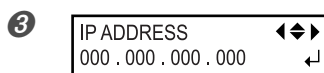

Press  three times.  
[IP ADDRESS]: 192.168.000.XXX

Note: Here, "XXX" may be any number you want from 2 to 254. However, be sure to specify a number that does not duplicate the setting you made in Step 1. Here, "192.168.000.003" is entered by way of example. Make the portion that corresponds to "192.168.000" the same as the setting on the computer.

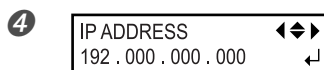

Use   to select the address number.

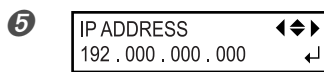

Press .

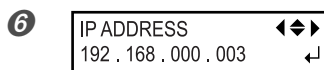

Repeat ④ and ⑤ to set all the address numbers.  
When you've finished making the setting, press .

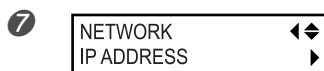

Press .  
The screen shown in the figure appears again.

### 2. Set the subnet mask.

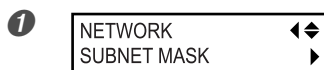

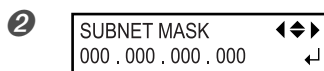

Press .

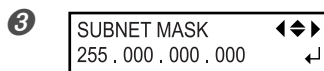

Press  twice.



Use   to select the address number.  
[SUBNET MASK]: 255.255.255.000

Note: For the subnet mask, make the setting the same value as the one used by the computer. Here, "255.255.255.000" is entered by way of example.



## 7. Network Settings

---

④

SUBNET MASK	◀▶
255 . 000 . 000 . 000	↵

Press .

⑤

SUBNET MASK	◀▶
255 . 255 . 255 . 000	↵

Repeat ③ and ④ to set the subnet mask.  
When you've finished making the setting, press .

If you're using one computer and one machine, go on to 4. If setting a gateway address is required, go on to 3.

### 3. Set the gateway address.

---



①

NETWORK	◀▶
SUBNET MASK	↵

Press .  
The screen shown in the figure appears again.



②

GATEWAY ADDR.	◀▶
000 . 000 . 000 . 000	↵

Press .  
Press  twice.

③

GATEWAY ADDR.	◀▶
255 . 000 . 000 . 000	↵

Use   to select the address number.  
[GATEWAY ADDR.]: 255.255.255.255  
For the value to enter for the gateway address, consult your network administrator.  
Here, "255.255.255.255" is entered by way of example.

④

GATEWAY ADDR.	◀▶
255 . 255 . 000 . 000	↵

Press .

⑤

GATEWAY ADDR.	◀▶
255 . 255 . 255 . 255	↵

Repeat ③ and ④ to set the gateway address numbers.  
When you've finished making the setting, press .

### 4. Finish making the settings.

---

①

SETUP SHEET
-------------

Press  to go back to the original screen.

## Step 3: Make the Port Settings for the Software RIP

Here you set the output destination port for the software RIP. For the output destination, use the setting for the IP address made on the machine. For information about how to make the settings, refer to the documentation for the software RIP.

You can check whether the connection to the network has been made by using the printing-test feature in the software RIP you're using. For information about how to carry out a printing test, refer to the documentation for the software RIP.

# 8. When Not in Use for a Prolonged Period

## Keep Performing Maintenance

### Switch On the Power Once a Month

Switch on the sub power once a month. When you turn on the power, the machine automatically performs some operations such as those to keep the print heads from drying out. Allowing the machine to stand completely unused for a prolonged period may damage the print heads, so be sure to switch on the power to perform these automatic operations.

### Keep at a Constant Temperature and Relative Humidity

Even when the machine is not in use, keep it at a temperature of 5 to 40°C (41 to 104°F) and a relative humidity of 20 to 80% (with no condensation). Temperatures that are too high may degrade the ink and cause malfunction. Temperatures that are too low may cause the ink to freeze and damage the heads.

## Alarm Feature



This function is to remind you to switch on the sub power once a month when you're using ECO-SOL MAX ink. When the machine remains unused for about one month, this screen appears and a warning beep sounds. If this screen appears, switch on the sub power. When maintenance operations finish, switch off the sub power.

This feature operates when the printer's main power is turned on. We recommend leaving on just the main power to the printer even when the machine is to remain out of use for a prolonged period.

## Important Note on Draining Ink

This machine has features for draining internal ink and for performing washing using cleaning cartridges, but they should never be used except in special cases. When you're using ECO-SOL MAX ink, allowing the machine to stand without ink for a prolonged period may damage the heads, even if internal washing is performed. Once ink has been filled, then as a rule the ink should never be drained.

# 9. When Moving the Unit

## Procedures from Preparing to Move Through Reinstalling











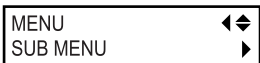



To move the machine, you must completely drain all ink inside the machine and secure the print heads in place with packing materials to protect them. Attempting to move the machine without first doing this may result in damage to internal components due to leaking ink or damage to the heads.

This operation requires four unused SOL INK cleaning cartridges. Have these on hand before you start.

### Important Notes on Moving

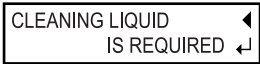
- > Be sure to use SOL INK cleaning cartridges. Use of any other type may result in breakdown.
- > Once the preparations for moving are complete, move the machine and fill it with ink with as little delay as possible. Allowing the machine to stand without ink may damage the heads.
- > When moving the machine, keep it at a temperature between 5 to 40°C (41 to 104°F) and at relative humidity between 20 to 80% (with no condensation). Failure to do so may result in breakdown.
- > Handle the machine with care when moving, keeping it level (not tilted at an angle) and preventing it from striking other objects.

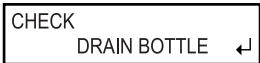
### 1. Drain the ink and wash the interior.

-  Press .  
Press  several times.
-  Press .  
Press  twice.
-  Press .  
Press  twice.  
Press .
-  Make sure the cleaning fluid is ready.  
Press .
-  Discard the discharged ink in the drain bottle.  
Be sure to discard the discharged ink.
- Attach the drain bottle and press .

Thereafter, follow the on-screen instructions to carry out the operations.  
After cleaning has finished, the sub power switches off automatically.

## 2. Secure the print heads in place.

---

- ① Remove the drain bottle and discard the discharged ink.  
Attach the bottom plug where the drain bottle was installed.
- ② Detach the blade holder.
- ③ Raise the loading lever.
- ④ Secure the print heads in place using the retainer.  
For information on how to secure in place, go to "3. Assembling and Installing" and refer to "Remove the Packing Materials."
- ⑤ Lower the roll media from the printer and detach the shafts.  
If necessary, also detach the left and right arms and the stand.  
The machine is now ready to be moved.

## 3. Immediately move the machine and fill it with ink.

---

- ① Once the preparations are complete, move the machine with as little delay as possible.
- ② Immediately reinstall the machine and fill with ink.  
To reinstall and fill with ink, carry out "3. Assembling and Installing" through "7. Network Setting." When filling with ink, you use the cleaning cartridges again.





1000002751