

Telemecanique Zelio-Logic Smart Relay

User's Guide
January 2000

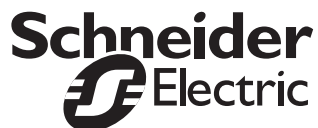

Preliminary Advice on Installing Smart Relays

Power down the device.

Take all necessary measures to avoid unwanted relay triggering.

Check to ensure that no voltage is present.

Make the necessary ground and short circuit connections.

Always follow the instructions stated in this user's guide.

Remember, only qualified personnel are authorized to implement the smart relay.

Automation and control devices must be installed so that they are protected against any risk of involuntary actuation.

It is essential to ensure that all control system connections meet applicable safety standards.

Fluctuations or variations in the mains supply voltage should not exceed the tolerance thresholds stated in the technical characteristics, as they may cause operating failures and lead to potentially dangerous situations.

Take care to meet the standards that apply to emergency stop systems in order to avoid potentially dangerous situations. Ensure that releasing the emergency stop system does not cause the automated system to suddenly restart.

Take all necessary measures to ensure that an application interrupted by a drop or a break in the supply voltage can continue correctly and also ensure that no dangerous states, no matter how brief, may occur.

Contents

You wish to know how your new smart relay works and discover its main characteristics.	Powering up and Discovering the Smart Relay	1
You require detailed information on, for example, implementing a Ladder diagram using a smart relay.	Implementing a Typical Application	2
You would like to know all of the smart relay's configuration options.	Configuration Menu	3
You would like to know all of the elements in the Ladder diagram that are recognized and used by the smart relay.	Ladder Diagrams	4
You would like to learn to enter a complete Ladder diagram using the smart relay.	Entering Ladder Diagrams	5
You would like to know what smart relay control capability remains during operation.	Debugging	6
You would like to improve your understanding of the smart relay using a complete example.	Application Example	7
You have an operating problem and you would like to find the solution.	Troubleshooting	8
You would like to back up, transfer or duplicate your application.	Transferring Ladder Diagrams	9
You are looking for information: Technical facts, Lexicon, Entry Forms.	Appendix	A
You are looking for a specific word.	Index	Index

Chapter 1 - Contents

Powering Up and Discovering the Smart Relay

This Chapter covers the following subjects:

1. Presentation	3
2. Characteristics and Connections	4
Characteristics	4
Connections	5
3. Command Keys	6
Description of the keys	6
4. Examples	7
5. Main Functions	10
Main menu	10
Configuration menu	11

1. Presentation

Smart relays are designed to simplify the electrical wiring of intelligent solutions. A smart relay is very simple to implement. Its flexibility and its high performance allow users to save significant amounts of time and money.

This User's Guide is intended for people who do not have an in-depth knowledge of automation systems and who would like to be able to implement these smart relays.

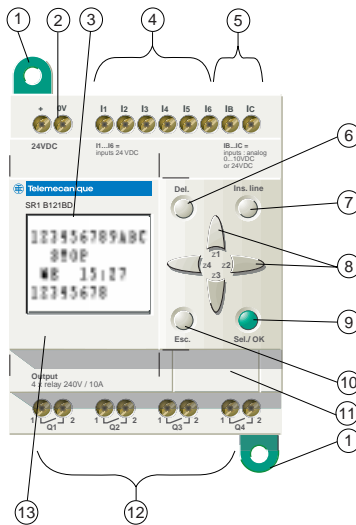

- 1-Retractable mounting feet
- 2-Power supply: 24 VDC for SR1●●●●BD, 100/240 VAC for SR1●●●●FU
- 3-LCD, 4 lines, 12 characters
- 4-Screw terminal block for 24 VDC inputs to SR1●●●●BD, 100/240 VAC to SR1●●●●FU
- 5-The SR1●●●●BD has analog 0-10 Volt inputs usable in 24 VDC discrete mode
- 6-Delete key
- 7-Insert line key
- 8-Arrow keys or after first configuring them, Z pushbuttons
- 9-Selection and validation key
- 10-Escape key
- 11-Connector for backup memory or PC connection cable
- 12-Relay output terminal block
- 13-Slot for re-writable label.

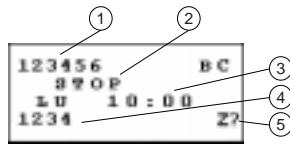

- 1-Input status display (B and C represent the analog inputs)
- 2-Operating mode display (RUN/STOP)
- 3-Parameter display, by default the day and time for models with a clock
- 4-Output status display
- 5-Z key function display, when these keys are activated.

2. Characteristics and Connections

Characteristics

Product	10 I/O	12 I/O	20 I/O	
References	SR1-A101BD	SR1-B121BD	SR1-A201BD	SR1-B201BD
Weekly clock	NO	YES	NO	YES
Supply voltage	24 VDC (19.2 VDC min./30 VDC max.)			
Rated input current	67 mA			
Discrete inputs Nbr.	6	6	12	10
Rated current	3mA			
Rated voltage	24 VDC			
Relay outputs Nbr.	4		8	
Voltage	5 ... 150 VDC /24 ... 250 VAC AC 15 0.9 A/230 V DC 13 0.6 A/24 V			
Analog inputs 0-10V Nbr.	0	2*	0	2*

* Each input is also usable in discrete I/O mode, 24 VDC

Product	10 I/O	20 I/O		
References	SR1-A101FU	SR1-B101FU	SR1-A201FU	SR1-B201FU
Weekly clock	NO	YES	NO	YES
Alimentation	100/240 VAC (85 VAC min. /264 VAV max.)			
Rated input current	< 46 mA at 115 VAC < 36 mA at 240 VAC			
Discrete inputs Nbr.	6		12	
Rated current	11/13 mA at 50/60 Hz			
Rated voltage	100/240 VAC			
Relay outputs Nbr.	4		8	
Voltage	5 ... 150 VDC/24 ... 250 VAC AC 15 0.9A/230V DC 13 0.6A/24V			

Note: AC smart relays do not have analog inputs. For further information, refer to the Catalog.

2. Characteristics and Connections

Connections

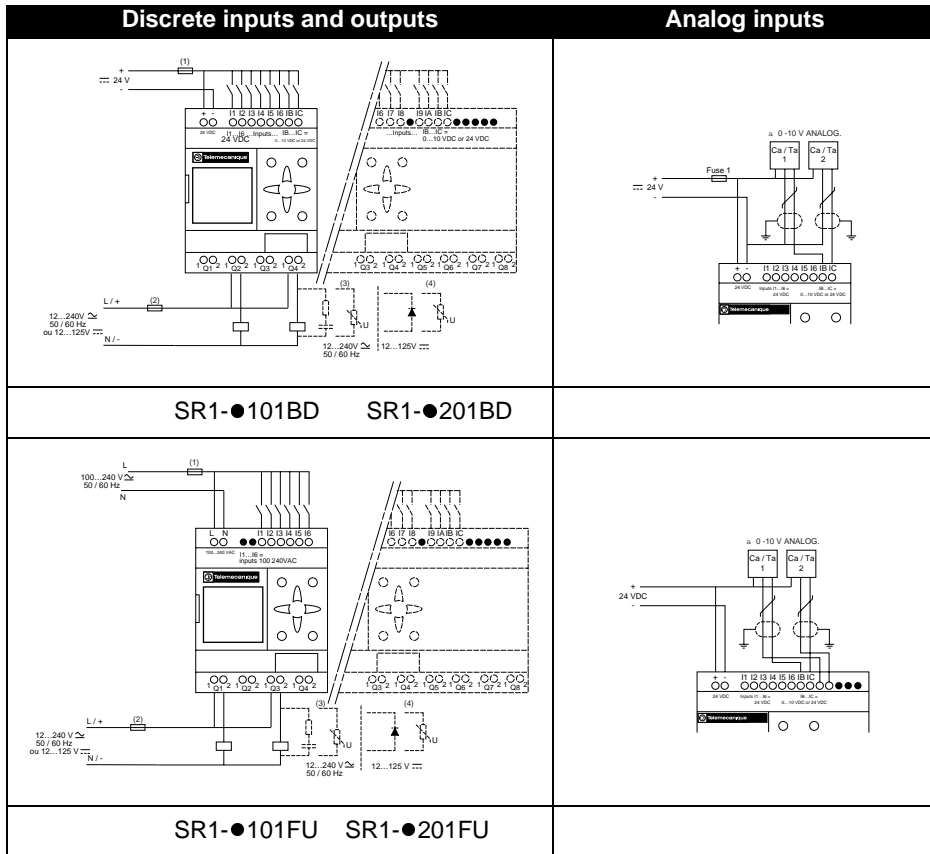



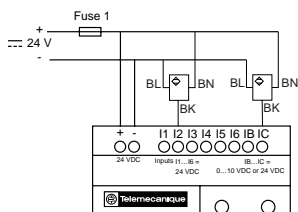

Three-wire connection



3. Command Keys

Description of the keys







The keys located on the front of the smart relay are used to configure, program and control the application.
They perform the following actions:

Key	Description
	Press this key to delete a Ladder diagram element or line.
	Press this key to insert a Ladder diagram line.
	Press this key to: Make a selection, Enter the parameter page for an element, Enter a display page, Validate a selection. To use the smart relay, the first action required is to press this key to access the main menu.
	Press this key to exit a menu or a selection.
	The arrow keys are used to move up, left, down and right. The position on screen is shown by a ">" index, a "■" or "●" cursor, the blinking text "Ini".

4. Examples





This sub-section details how to use the smart relay's keys.

Example 1: Language selection - The procedure described below is always the same, regardless of the product.

Description/Action	Display
<p>Initial power up or power up after initialization by the manufacturer:</p>	 <p>The "ENGLISH" option blinks.</p>
 <p>To select French.</p>	 <p>The Sel./OK button is used to validate the choice of a new language (as shown by the lozenge symbol and by the text blinking).</p>
 <p>To continue or complete the initial power up procedure.</p>	<p>There are two possible cases: Product with a clock, SR1-B●●●●●●</p>  <p>Now the time must be set (refer to the example on the next page)</p> <p>Product without a clock, SR1-A●●●●●●</p>  <p>The smart relay's main screen is displayed (in this case an SR1-A101FU smart relay).</p>

4. Examples



Example 2: Changing the date and time when first powered up.

Description/Action	Display/Comments
<p>After choosing the language, the following screen is brought up:</p>	<div data-bbox="700 318 933 418" style="border: 1px solid black; padding: 5px; text-align: center;"> TIME SET: █ WINTER MO 00:00 </div> <p>The black colored cursor blinks.</p>
<div data-bbox="322 578 381 643" style="text-align: center;">  </div> <p>To enter Modify mode.</p>	<div data-bbox="700 480 933 581" style="border: 1px solid black; padding: 5px; text-align: center;"> TIME SET: WINTER MO 00:00 </div> <p>The text to change blinks ("WINTER" in this case). You can then change it using:</p> <div data-bbox="642 643 912 724" style="text-align: center;">  or  then  </div> <p>Pressing Sel./OK validates the change.</p>

The hours, minutes and day of the week settings can be changed in the same way, using the smart relay keys.

To return to the main menu, press:



Note: The  or  keys are used to move from one field to another while the other two arrow key pad keys are used to change the displayed values.

5. Main Functions

These are grouped in a main menu.

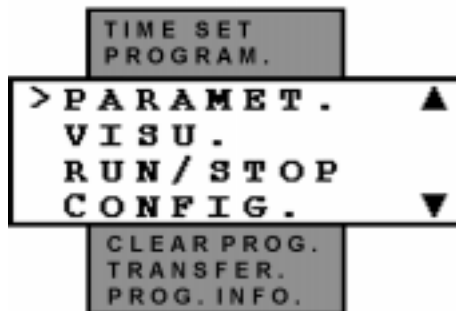

The ">" indicator located to the left of the text shows the setting of your choice.

An upwards triangle indicates that there are more options available if you scroll up, while a downwards triangle indicates that there are more options available if you scroll down.

5. Main Functions

Main menu

Menu	Description
TIME SET	This function is used to set the date and time: Summer time/Winter time Day of the week Hours-Minutes
PROGRAM.	This function lets the user enter the Ladder diagram that will make the smart relay work. This program is written using a Ladder diagram. For information on how to program a Ladder diagram, refer to the next Chapter. This function may be password protected.
PARAMET.	This function lets the user display and change unlocked parameters in elements entered in the Ladder diagram.
VISU.	This function lets the user display and change unlocked function block parameters entered in the Ladder diagram. It also lets the user select data that will be displayed on the third display line on the smart relay screen.
RUN/STOP	This function lets the user start or stop the program contained in the smart relay: RUN: the program is started. STOP: the program is stopped and the outputs disabled.
CONFIG.	This function comprises all of the smart relay configuration options (refer to the next table).
CLEAR PROG.	This function will clear the entire Ladder diagram stored in the smart relay. This function may be password protected.
TRANSFER.	This function will transfer the contents of the smart relay memory. Modul. -> PC: transfer to the programming software, PC -> Modul.: loading by the programming software, Modul. -> Mem: transfer to the unpluggable EEPROM*, Mem -> Modul.: loading from the unpluggable EEPROM*.
PROG. INFO.	This function will display all of the elements required for entering a Ladder diagram.

* The unpluggable EEPROM allows transferring the contents of the smart relay memory without the need for the programming software and without the need to enter an identical application in another smart relay. However, the smart relay can still work without an EEPROM.

5. Main Functions

Configuration

Menu	Description
PASSWORD	Allows or denies access to certain functions.
LANGUAGE	Language selection.
Filt.	Input filtering mode selection (for fast inputs). This function may be password protected.
Zx=KEYS	Enable/disable arrow keys Zx. This function may be password protected.
HELP	Enable/disable automatic help.

The various configuration menu options are detailed in Chapter 3, page 24.

Chapter 2 - Contents

Implementing a Basic Application

This Chapter covers the following subjects:

1. Ladder Diagram Presentation	13
2. Using the Reverse Function	14
Practical example	14
General case	15
3. Notation Used by the Smart Relay	16
4. Application: Implementing a Two-way Switch	18
Entering the Ladder Diagram	18

1. Ladder Diagram Presentation

If you already know how Ladder diagrams work, you can skip straight to Section 3 of this Chapter.

In this section, we will use a simple example to understand how a Ladder diagram works: a two-way switch.

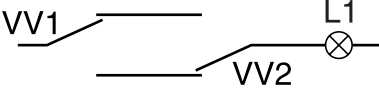
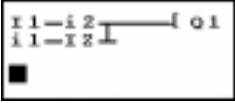
Normal electrical diagram	Ladder diagram
	
<p>The two position switches identified as VV1 and VV2 control the light L1.</p>	<p>I1 and I2 are two contacts representing inputs 1 and 2 on the smart relay. Q1 is a coil that corresponds to output 1 from the smart relay.</p>

Using a smart relay means that simple switches (with open or closed positions) can be used in place of position switches.

The switches are identified as **S1** and **S2** in the wiring diagram opposite.

S1 and **S2** are connected to inputs **I1** and **I2** on the smart relay.

The operating principle is as follows:

Each time inputs **I1** and **I2** change state, this causes a change in state on output **Q1** which controls lamp **L1**.

The Ladder diagram uses basic features like placing contacts in parallel and in series along with the reverse function identified as **i1** and **i2** (the reverse function is described on the next page).

Note: The implementation of a two-way switch is optimum when remote control relay coils are used (refer to page 33).

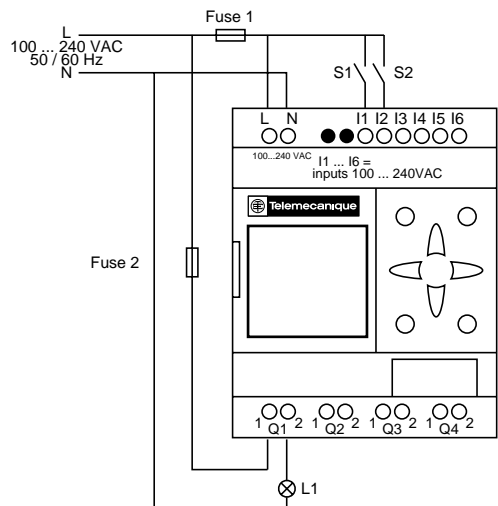

2. Using the Reverse Function

Practical example

The reverse function and its **i** notation in the smart relay is used to obtain the reverse state of input **I** wired on the smart relay. To illustrate how this function works, let us use a simple electrical diagram:

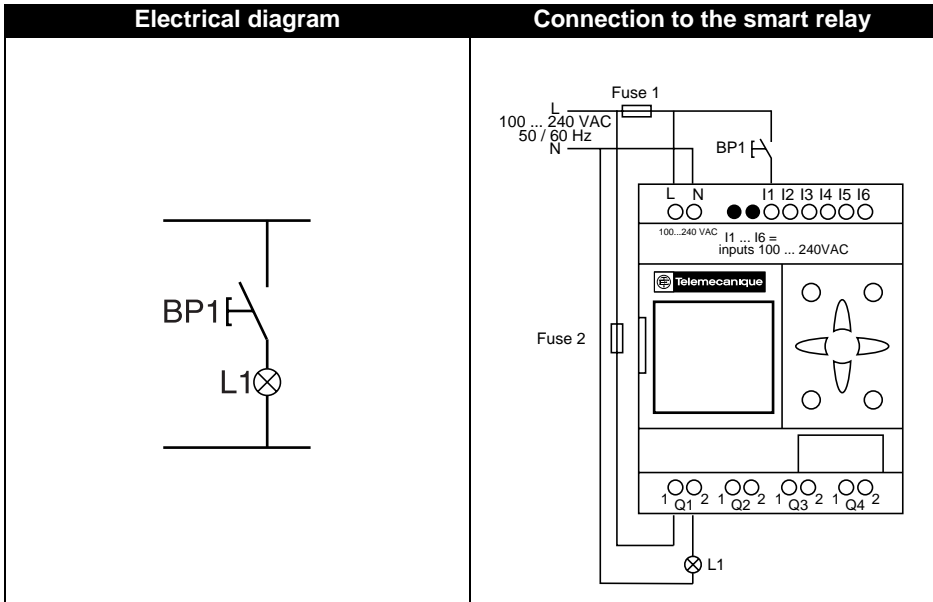

Depending on the Ladder diagram, there are two possible solutions:

Ladder diagram 1 Light out when idle	Ladder diagram 2 Light lit when idle
$\overline{I1} \text{ ————— } [Q1$	$i1 \text{ ————— } [Q1$
<p>I1 corresponds to the true image of BP1, pressing BP1 activates input I1 so that the Q1 output is activated and light L1 lights.</p>	<p>i1 corresponds to the reverse image of BP1, pressing BP1 activates input i1 therefore contact i1 is disabled, output Q1 is disabled and light L1 goes out.</p>

2. Using the Reverse Function

General case

The table below illustrates the operation of a pushbutton connected to the smart relay. Pushbutton **BP1** is connected to input **I1** and the light **L1** is connected to output **Q1** on the smart relay.







Idle		Operating	
Electrical diagram	Zelio symbol	Electrical diagram	Zelio symbol
	I1 = 0 i1 = 1		I1 = 1 i1 = 0
	I1 = 1 i1 = 0		I1 = 0 i1 = 1

Note: The reverse function applies to all of the contacts in a Ladder diagram, whether they represent outputs, auxiliary relays or function blocks.

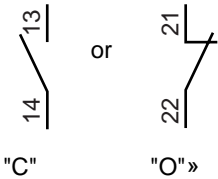
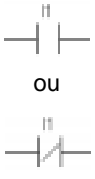
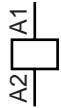
3. Notation Used by the Smart Relay

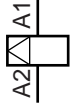
The smart relay has a four line display used to show Ladder diagrams. The table below shows the symbol notation used for basic elements.

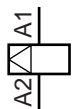
Note: The ZelioSoft application lets you represent Ladder diagrams in three different formats

Electrical symbol	Ladder diagram symbol	Zelio symbol
 <p>or</p>		<p>I1 or i1</p> <p>I1 or i1</p>
		<p>I Q1</p>
 <p>Set coil (SET)</p>		<p>s Q1</p>
 <p>Reset coil (RESET)</p>		<p>R Q1</p>

3. Notation Used by the Smart Relay

Other elements are also available using a smart relay:

Timer function block: used to delay, prolong and control an action for a set length of time.

Counter function block: used to count the pulses received on an input.

Clock function block: used to trigger or release actions on precise days or at precise times.

Analog comparator function block: used to compare an analog value with a reference value or with another analog value after allowing for a hysteresis factor.

Auxiliary relays: these are used to save or relay the status of the smart relay.

Z keys: after confirming this function, Z keys can be used as push buttons.

Note: For more information on all of the Ladder diagram elements available when using a smart relay, refer to Chapter 4, page 30 for a detailed description.

4. Application: Implementing a Two-way Switch







Entering the Ladder diagram

By following the indications in the table below, the user can enter the two-way switch Ladder diagram.

From the main screen (the one shown on power-up), follow the instructions shown in the "**Action**" column and press the specified button.

The "**Screen**" button shows what the user will see on the smart relay screen.











The "**Comments**" column provides some additional information on entry and display actions.

Action	Screen	Comments
		The main menu is displayed, the ">" symbol shows that the " PROGRAM. " option is selected. This option blinks.
		After briefly displaying " LINE 1 " (for approx. 2 seconds), a blinking black box is displayed.
	I	The I blinks. The smart relay prompts the user to select the type of contact.
	I1	The 1 blinks. You have implicitly selected a contact assigned to an input (I), the smart relay now prompts you to select the input number.













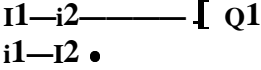

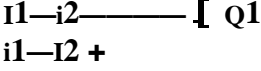
4. Application: Implementing a Two-way Switch

Action	Screen	Comments
	I1 ■	The ■ blinks. You have just validated the contact entry to assign to input I1. The ■ is moved ready to enter the second contact.
	I1—i1	The right hand I blinks. The smart relay prompts you to select the type of contact.
	I1—i1	The i blinks. You have just selected the reverse contact assigned to an input.
	I1—i1	The right hand 1 blinks. Now enter the input number.
	I1—i2	The 2 blinks. Now simply validate this selection.
	I1—i2 ■	The ■ blinks. Move to the end of the line ready to enter the coil.
	I1—i2 •	The • blinks, this indicates a link point for linking connections.
	I1—i2 ■	The ■ blinks. Now enter the coil.
	I1—i2——— I Q1	The Q blinks. Now all that remains is to select the other parameters for this coil.





4. Application: Implementing a Two-way Switch

Action	Screen	Comments
	$I1-i2$ ———— \lfloor Q1	The 1 blinks. Coil Q is validated.
	$I1-i2$ ———— \lfloor Q1	The \lfloor blinks. The coil number is validated.
	$I1-i2$ ———— \lfloor Q1 ■	The ■ blinks. The coil is validated based on contact position. The ■ moves down a line and the links are displayed automatically.
	$I1-i2$ ———— \lfloor Q1 I1	The I located on the second line blinks.
	$I1-i2$ ———— \lfloor Q1 i1	The i located on the second line blinks.
	$I1-i2$ ———— \lfloor Q1 i1	The 1 located on the second line blinks.
	$I1-i2$ ———— \lfloor Q1 i1 ■	The ■ blinks.
	$I1-i2$ ———— \lfloor Q1 i1—I1	The I on the second line blinks.
	$I1-i2$ ———— \lfloor Q1 i1—I1	The second 1 in the second line blinks.
	$I1-i2$ ———— \lfloor Q1 i1—I2	The 2 in the second line blinks.

4. Application: Implementing a Two-way Switch

Action	Screen	Comments
		The ■ blinks. Now enter the link between the two lines.
		The ● blinks. This shows that it is possible to connect a link at this point.
		The + blinks. It has replaced the ● and indicates that it is now possible to set the link between the two lines.
		The contact point blinks showing a + sign. Now validate the change.
		The contact point blinks showing a ● sign. The validation is made, now exit the diagram zone.
		The screen displays the main menu. Now start the smart relay (Set to RUN).
Press three times 		The ">" sign indicates that the " RUN/STOP " option is selected. This option blinks. Now simply validate the setting to RUN .
		The smart relay prompts you to validate RUN mode.

4. Application: Implementing a Two-way Switch

Action	Screen	Comments
		The smart relay is now set to RUN. To monitor its operation, return to the main screen.
		This screen lets the user display two-way switch operation (switch action, indicator lights on or off, light on or off).

This simple application example teaches the user how to enter a Ladder diagram. The following points should be remembered:

When a ■ or a ● blinks, use the **Sel/Ok** button to add an element (contact, coil or graphic link element).

When an element blinks (I, Q, N°, ■, ...), it is possible to use the **Z1** and **Z3** arrows on the arrow key pad to select the required element.

It is also possible to use the **Z2** or **Z4** arrows on the key pad to select the previous or next elements (or the next part of the current element).

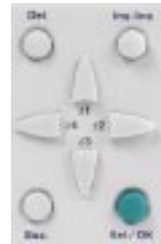

Chapter 3 - Contents

Configuration Menu

This Chapter covers the following subjects:

1. Password Function "PASSWORD"	25
Password purpose	25
Entering the password	25
Cancelling password protection	25
Changing the password	25
2. Language Selection Function "LANGUAGE"	26
Using the "Ini." function	26
3. Fast Input Function "FILT."	27
4. Arrow Keys Function "Zx=KEYS"	28
5. Help Function "HELP"	29







1. Password Function "PASSWORD"

Password purpose

The password secures access to the following main menu options: "PROGRAM.", "CLEAR PROG", "FILT.", "Zx=KEYS", as well as to the two application transfer options **Module to PC** and **Module to EEPROM**.

Note: This password comprises four digits from 0 to 9. It is entered using the keys on the smart relay. By default it is disabled.

Entering the password

Action	Display	Comments
Select the "PASSWORD" option from the "CONFIG." menu.	PASSWORD  ? ? ? ?	The  means that no password is set yet.
	PASSWORD  0 0 0 0	The 0 on the right blinks. Now enter the password.
Enter the password using the arrow keys Z1, Z2, Z3, Z4.	PASSWORD  3 0 2 0	The digit being changed blinks. Now validate the entry made.
	PASSWORD 	This screen is displayed for two seconds (the password is activated) and the user is returned to the main menu.

Cancelling password protection

To cancel password protection, simply enter the current password (see above). The password is inhibited and the smart relay displays a transitory screen showing **OFF**. If you have forgotten your password, refer to Chapter 8, page 71.

Changing the password

To change the password, simply cancel the former one and enter a new one (refer to the method described above).

2. Language Selection Function "LANGUAGE"

This function lets the user choose the language used by the smart relay. All messages can be displayed in six languages: English, French, German, Italian, Spanish and Portuguese.

Example: Language selection screen.



In this example, French is chosen.

Note: No language selection can be made with the smart relay in RUN.

Using the "Ini." function

When the **Ini.** function is selected, the next time the smart relay is powered up, it prompts the user to select a language and enter the time (for smart relays with a clock function).

3. Fast Input Function "FILT."

This function allows faster detection of changes in states on the inputs. This mode should only be used when necessary as it makes the smart relay's inputs more sensitive to interference and signal bounce.

Two choices are available: "FAST" and "SLOW". This function is available on DC smart relays.

Note: This selection can only be made when the smart relay is set to STOP. By default, smart relays are configured to run in "SLOW" mode.

References	Filtering	Switching	Standard discrete input	Analog inputs
SR1A121BD	SLOW	ON->OFF	5 ms	5 ms
SR1B121BD		OFF->ON	3 ms	3 ms
SR1A221BD	FAST	ON->OFF	0.5 ms	Rated: 0.3 ms Max.: 0.5 ms
SR1B221BD		OFF->ON	0.3 ms	Rated: 0.2 ms Max.: 0.3 ms

The other (AC) modules only have one set filtering value that cannot be changed and which is dependent on the supply voltage. Refer to the technical characteristics provided in the Catalog.

4. Arrow Keys Function "Zx=KEYS"

The "**Zx=KEYS**" option lets the user enable or disable the use of arrow keys as pushbuttons.

When these keys are disabled, they are only available for setting parameters, configuring and programming the smart relay.

When these keys are enabled, it is also possible to use them in a Ladder diagram.

They work like pushbuttons without the need to use a terminal block input contact.

Representation	State	N°	Description
Z N°	Normally open	1 to 4	Representation of the smart relay's arrow keys, this contact shows the state of the corresponding key. Z1 Up arrow Z2 Right arrow Z3 Down arrow Z4 Left arrow
z N°	Normally closed		

Note: By default this function is inactive.

5. Help Function "HELP"

This function lets the user enable or disable the automatic help function when performing a smart relay parameter setting or programming action.



When the help function is enabled, simply remain on the required element for a few seconds without pressing on a key and help will be displayed in the form of an explanation screen.



To exit the screen, press on the or buttons.

Example of a help screen:

When setting function block parameters, holding position over the padlock symbol will cause the "**modif. param.**" message to appear. Locking does indeed stop the function block from being displayed in the parameter menu.

Chapter 4 - Contents

Ladder Diagrams

This Chapter covers the following subjects:

1. Introduction	31
2. Discrete Inputs	32
3. Discrete Outputs	33
Used as a Coil	33
Used as a Contact	33
Example - Using a remote control relay	34
Example - Using Set and Reset Coils	34
4. Auxiliary Relays	35
Example - Using an Auxiliary Relay	35
5. Arrow Keys	36
Example - Using the "Up Arrow" key	36
6. Clock Function Block	37
Clock function block contacts	37
Clock function block parameters	38
Example - Time management using a Clock function block	39
7. Counter Function Block	41
Counter function block contacts	41
Counter function block coils and parameters	41
8. Timer Function Block	43
Timer function block contacts	43
Timer function block parameters	43
Example - Using a Timer function block	46
9. Analog Function Block	47
Analog function block contacts	47
Analog function block parameters	48

1. Introduction

This Section details all possible elements in a Ladder diagram that are recognized and used by the smart relays. To better understand the functions performed by each element, where necessary a directly usable example is included.

The logic modules accept 60 line Ladder diagrams for 10 I/O smart relays and 80 line ones for 20 I/O smart relays.

Note: Each line comprises a maximum of three contacts and must include a coil. When the application requires more than three contacts to activate an action, the auxiliary relays can be used as shown in the example below.

Ladder diagram example:

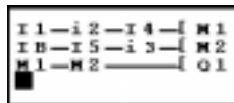

2. Discrete Inputs

A discrete input can only be used as a contact.

Representation	Function	N°	Description
I N°	Normal	1 to C depends on the module	The physical input to the smart relay. This contact gives the state of the sensor (switch, detector,...) connected to the corresponding input.
i N°	Reversed		

Example 1:



When the input **I1** contact is closed, output **Q1** is activated.

Example 2:



When the input **I1** contact is not closed, output **Q1** is activated.

3. Discrete Outputs

A discrete output can be used either as a contact or a coil.

Used as a coil

Usage mode	Nbr. on term. blk.	Description
I QN°	1 to C depends on the module	The coil is supplied if the contacts that it is connected to are closed ones, else it is not supplied.
J QN°		Pulse supply, the coil is supplied by a change of state. This is the same as a remote control relay.
S QN°		"Set" or triggered coil. This coil triggered as soon as the contacts that it is connected to are closed. It remains triggered even if the contacts are no longer closed.
R QN°		"Reset" coil, also called a release coil. This coil is disabled when the contacts that it is connected to are closed. It remains idle even if the connects are no longer closed.

Used as a contact

Representation	Function	N°	Description
Q N°	Normal	1 to 8 depending on the module	A physical output from the smart relay.
q N°	Normally closed		An output can be used as a contact to determine its state at a given time.

Example 1:

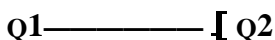

When output **Q1** is activated, output **Q2** is also activated.

Example 2:



When output **Q1** is disables, output **Q2** is activated. Output **Q2** will always take the reverse state to output **Q1**.

3. Discrete Outputs

Note: Using the \lceil and \lfloor functions only once in each coil in a Ladder diagram is recommended.

Additionally, if a SET coil (S function) is used, a line must always be provided in the diagram to disable this coil using a RESET (R function).

If not, then during operation, there is always the risk of generating unexpected switching states.

Example - Using a remote control relay

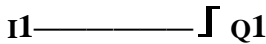

A very handy function, that allows lighting and extinguishing a light using a pushbutton. If a pushbutton is connected to input **I1** and a light to output **Q1**, then each time the button is pressed, the light will come on if it was off or it will go off if it was lit.

Example - Using Set and Reset coils

To control the power supply to a device using a pushbutton and to use a second pushbutton to cut-off the power supply to the same device. The following solution is applied:

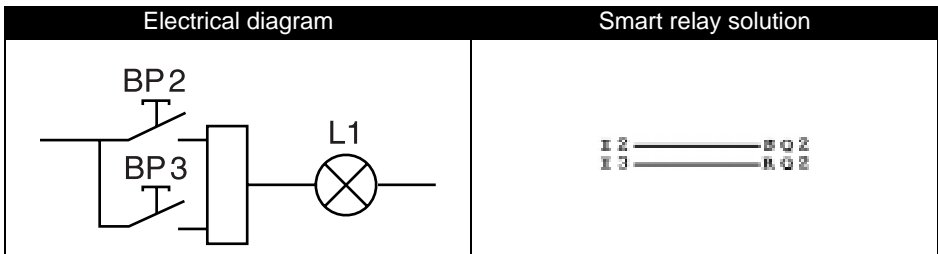

Pushbutton BP2 is connected to the smart relay, to input I2, and pushbutton BP3 is connected to input I3. The device to control, in this case a light bulb called L1 is connected output Q2.
Pressing pushbutton BP2 will light the bulb.
Pressing pushbutton BP3 will extinguish the bulb.

4. Auxiliary Relays

The auxiliary relays, **M** in the notation used, operate just like the output coils **Q**. The only difference is that they do not have any connection terminals.

There are 15 auxiliary relays (numbered in hexadecimal notation from 1 to 9 and from A to F).

They are used to save or forward a state. This saved or forwarded state will then be used as the assigned contact.

Example - Using an auxiliary relay

Using two auxiliary relays to save the position of a number of inputs. The saved state is then used to control a coil.

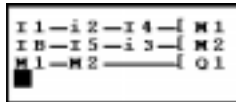

This type of diagram is often used to control the various states of a device.

5. Arrow Keys

The arrow keys work just like the physical inputs **I**. The only difference is that they do not have any connection terminals.

There are four arrow keys (**Z1**, **Z2**, **Z3**, **Z4**).

They are used as pushbuttons.

They can only be used as contacts:

Representation	Function	N°	Description
Z N°	Normal	1 to 4	Representation of the arrow keys on the smart relay. This contact gives the state of the corresponding key. Z1 Up arrow Z2 Right arrow Z3 Down arrow Z4 Left arrow
z N°	Reverse		

Note: So that the arrow keys may be used in this way, first check that they are activated in the "**Zx=KEYS**" option in the "**CONFIG.**" menu.

If not, when the smart relay is in RUN mode, they keys are only used to move within the menus.

Access to the "**Zx=KEYS**" option is locked out when password protection is activated.

Example - Using the "Up Arrow" key

This example shows how to set up a remote control relay that will work using key **Z1** and output **Q1**.

Z1 ————— **I** **Q1**



Each time the  key is pressed, output **Q1** changes state.

6. Clock Function Block



The Clock function block is used to validate time slots during which actions can be performed. It acts just like a programmable weekly timer and has four operating ranges (A, B, C, D) used to control its output.

The block's parameter settings are accessible in two ways:

- When entering a diagram line,
- From the "**PARAMET.**" menu, if the function block is not padlocked.

The following contacts can be used in a Ladder diagram:

Clock function block contacts

Representation	Function	N°	Description
 N°	Normal	1 to 4	The contact is closed when the Clock is in an enabled period.
 N°	Reverse		The contact is closed when the Clock is not in an enabled period.

6. Clock Function Block

Clock function block parameters

- 1 - Block number
- 2 - Operating ranges
- 3 - Current date and time
- 4 - Start day
- 5 - End day
- 6 - Start time
- 7 - Stop time
- 8 - Block locking

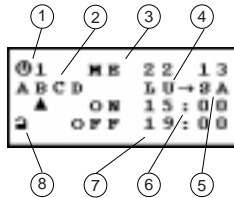

Parameter		Description
Block Number	①	Four blocks can be used, numbered from 1 to 4. This parameter cannot be changed in the screen shown above. It is chosen when the block is entered in the diagram line.
Operating ranges	②	Four operating ranges are available A, B, C, D. During operation, these ranges are cumulated: The block is valid over all of the selected ranges.
Current date and time	③	This date corresponds to the day of the week (Monday to Sunday).
Start day	④	For each range, a start of validity day (Monday to Sunday) is specified.
End day	⑤	For each range, an end of validity day (Monday to Sunday) is specified.
Start time	⑥	For each range, a start operating time (00:00 to 23:59) is specified.
Stop time	⑦	For each range, a stop operating time (00:00 to 23:59) is specified.
Block locking	⑧	Each Clock block can be locked or left unlocked. When locked, the Clock function block no longer appears in the "PARAMET." menu.

When validating the Clock block parameters (exiting the screen using the ESC key), the smart relay displays a summary of the block's validity ranges so that the user can check the data that they entered.

6. Clock Function Block

Example - Time management using a Clock function block

To control a device during the day and using two time slots: from 09:00 to 13:00 and from 15:00 to 19:00. The device is connected to smart relay output **Q2** and Clock function block 1 is used.

The Ladder diagram line is as follows:



When **1** is entered, the user must specify the operating ranges.

Note: The following keys are used: **Sel./OK** to select or validate a parameter, **Z1** and **Z3** to change the value of the selected parameter, **Z2** and **Z4** to move from one parameter to another.

Screen	Comments
<pre> 1 TU 22:47 ABCD - - - - ▲ ON - - - - ■ OFF - - - - </pre>	First data entry screen. It is displayed blank and is filled-in using the arrow keys.
<pre> 1 TU 22:49 ABCD MO-3A ▲ ON 09:00 ■ OFF 13:00 </pre>	The first range (A) has been entered: from Monday to Friday and from 09:00 to 13:00. Now enter the second range.
<pre> 1 TU 22:49 ABCD - - - - ▲ ON - - - - ■ OFF - - - - </pre>	The second range has now been chosen. It is displayed blank. Now enter the times for this new range.
<pre> 1 TU 22:50 ABCD MO-3A ▲ ON 15:00 ■ OFF 19:00 </pre>	The second range has now been entered: from Monday to Saturday and from 15:00 to 19:00. Now simply exit this data entry screen by pressing Esc .

Note: The example described in Chapter 7 describes another way of using time slots. It is possible to mix the two in order to resolve complicated cases.

6. Clock Function Block

Once data entry is complete, the smart relay displays a summary table that shows all of the operating ranges. To scroll it, use the arrow keys.

The example entered on the previous page results in the following summary table:

⊕ PROGRAM .		
MO	ON	09:00
	OFF	13:00
	ON	15:00
	OFF	19:00
TU	ON	09:00
	OFF	13:00
	ON	15:00
	OFF	19:00
WE	ON	09:00
	OFF	13:00
	ON	15:00
	OFF	19:00
TH	ON	09:00
	OFF	13:00
	ON	15:00
	OFF	19:00
FR	ON	09:00
	OFF	13:00
	ON	15:00
	OFF	19:00
SA	ON	09:00
	OFF	13:00
	ON	15:00
	OFF	19:00

To return to entering diagram lines, press **Esc**.

7. Counter Function Block

The Counter function is used to count pulses. It can be reset and a graphic element used as the contact will show whether the preset value has been reached.

Function block parameter setting can be accessed: when entering the coil that represents the counter input (CCN° in the notation used) in the diagram line.

The "PARAMET." menu is used to change the preset value if the function block is not padlocked.

Counter function block contacts

Representation	Function	N°	Description
CN°	Normal	1 to 8	The contact is closed when the counter reaches the preset value.
CN°	Reverse		The contact is closed until the counter has reached its preset value.

Counter function block coils and parameters

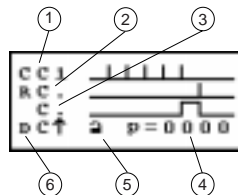

- 1 – Counter input
- 2 – Reset input
- 3 – Validity output - when the preset is reached
- 4 – Value to reach - also called the preset value
- 5 – Block locking.
- 6 – Counter direction input (up/down counting)

Note: This screen is only displayed when the coil corresponding to the counter input is entered. The only parameter that can be changed is the preset value. Its value is between 0 and 9999. When a point is displayed in this screen, it indicates that the element was not used in the diagram lines.

7. Counter Function Block

Element	Description/Use	Example
CC	Used as a coil in a Ladder diagram, this element represents the block's counter input. Each time the coil is triggered, the counter increments or decrements by 1, depending on the chosen counting direction.	Application example: Counting on the input to the Counter N°1 function block. I1 ————— CC1
RC	Used as a coil in a Ladder diagram, this element represents the reset input for the Counter block. Triggering the coil will reset the current count value to zero.	Application example: Resets Counter N°1 when the Up Arrow key is pressed on the arrow keypad. Z1 ————— RC1
DC	Used as a coil in a Ladder diagram, this element represents the counter input that determines the direction of counting. If this coil is triggered, the function block downcounts. The function block upcounts by default (this input is not wired).	Application example: Up or downcounting depending on the state of a smart relay input. I2 ————— DC1
p=0000	Value to reach. This value is also called the preset value. When the current counter value equals the preset value, then Counter contact C is closed. This value can be changed from the previously described screen and also from the "PARAMET." menu.	
	This parameter is used to lock the Counter function block. When the block is locked, the preset value no longer appears in the "PARAMET." menu.	
C or c	Used as a contact, this Counter function block element indicates that the preset value and the current value are equal.	Application example: Lighting an indicator light connected to smart relay output 1 when the preset value is reached. Else the indicator light is out. C1 ————— Q1

8. Timer Function Block

The Timer function is used to delay, prolong and control actions during a set period of time. It has a reset input, a command input and an output used to indicate time-out.

The function block's parameter settings can be accessed when entering the control coil (TTN° in the notation used) in the diagram line. The "PARAMET." menu is used to change the preset value if the function block is not padlocked.

Timer function block contacts

Representation	Function	N°	Description
TN°	Normal	1 to 8	The operation of this output depends on the Timer parameter settings. The possible parameter settings are described in the remainder of this Sub-section.
ttN°	Reverse		

Timer function block coils and parameters

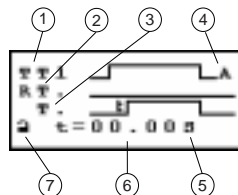

- 1 – Timer control input
- 2 – Timer reset input
- 3 – Control output (or when the Preset time is reached)
- 4 – Type of Timer (8 possible types, refer to the next page)
- 5 – Preset time unit.
- 6 – Preset time, the time value to be reached
- 7 – Timer preset value lock







Note: This screen is only displayed when the coil corresponding to the Timer control input is entered.

When a point is displayed in this screen, it indicates that the element was not used in the diagram lines.

8. Timer Function Block

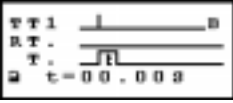
Element	Description/Use
TT	Used as a coil in a Ladder diagram, this element represents the Timer function block control input. Its operation depends on the type selected (refer to the table on the next page for further details).
RT	Used as a coil in a Ladder diagram, this element represents the reset input. Triggering the coil will reset the current Timer value to zero. The T contact is disabled and the block is ready for a new timer cycle.
Type	There are 8 types of Timer. Each type triggers a specific kind of operation used to handle all possible cases in an application. The table on the next page provides a detailed description of these 8 types.
t=00.00	Preset value, or the timer value to be reached. The effect of this value varies depending on the type used (refer to the table on the next page for further details).
s	Preset value time unit. There are four possible cases: 1/100 ths. of a second: 00.00 s Maximum: 99.99 1/10 ths. of a second: 000.0 s Maximum: 999.9 Minutes: seconds: 00:00 M:S Maximum: 99 :59 Hours: minutes: 00:00 H:M Maximum: 99 :59
🔒	This parameter is used to lock the Timer function block preset value. Once locked, the preset value is no longer displayed in the "PARAMET." screen..
T or t	Used as a contact, this function block element represents the Timer output. Its operation depends on the type selected (refer to the table on the next page for further details).

8. Timer Function Block

Type	Description
	<p>Type A: Trigger delay (working contact delay). Example: To delay triggering a contactor to limit the current level required.</p>
	<p>Type a: Trigger delay on a pulse rising edge with reset.</p>
	<p>Type C: Trigger delay (idle contact delay). Example: To maintain fan operation after stopping the engine.</p>
	<p>Type B: Calibrated pulse on the control input rising edge (passage contact). Example: To trigger a timed lighting circuit using a pushbutton and a timer.</p>
	<p>Type W: Calibrated pulse on the control input falling edge. Example: Closing a toll gate.</p>
	<p>Type D: Symmetrical blinker. Example: Indicating a failure using a flashing light.</p>
	<p>Type d: Symmetrical blinker triggered by the rising edge on the control input with a Reset function. Example: A pulse triggered brake control function after power is cut.</p>
	<p>Type T: A totalizing count with Reset. Example: To request the replacement of a filter when the recommended service life is exceeded.</p>

8. Timer Function Block

Example - Using a Timer function block

Implementing a stairway lighting timer:
 The pushbuttons on each floor are connected to smart relay input **I1**.
 The Timer N°1 function block, set for a two minute, thirty second duration, controls output **Q4**.
 Output **Q4** is connected to the lighting system.

The Ladder diagram lines are as follows:

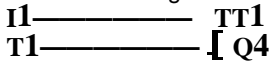

When entering **TT1** the Timer function block parameters must be set.

Note: The following keys are used, **Sel./OK** to select or validate a parameter, **Z1** and **Z3** to change the value of the selected parameter, **Z2** and **Z4** to move from one parameter to another.

Screen	Comment
	This is the first screen. First select the type of Timer function block.
	Once the type of Timer function block is selected: type B, calibrated pulse. Now select the time base.
	Once the time base is selected M: S . Now enter the required duration.
	Once the duration has been selected, parameter setting is complete. Press Esc. to return to diagram line entry.

Note: To start the timer, do not forget to set the smart relay to **RUN**.

9. Analog Function Block

The analog function blocks can be used with the following smart relay references: SR1A121BD, SR1B121BD, SR1A221BD and SR1A221BD. These are DC supplied smart relays. These modules allow the use of two discrete inputs, **IB** and **IC** in the notation used, and they can accept input values from 0 to 10V.

Analog function block are used to compare a measured analog value with an internal reference value and also to compare two measured analog values. This analog function is used in the form of a contact.

Function block parameters can be set: when the contact representing the Analog function block (**AN°**) is entered in the diagram line.

The "**PARAMET.**" menu lets the user change the reference or hysteresis value depending on the type of function block chosen.

Analog function block contacts

Representation	Function	N°	Description
AN°	Normal	1 to 8	The contact shows the position of a measured analog value in relation to a reference value or it represents a comparison between two measured analog values. It's value depends on the type of Analog function block chosen and configured.
aN°	Reverse		

Note: An analog function block is only used as a contact.

9. Analog Function Block

Analog function block parameters

When entering a contact in a diagram line, the user must state the type of analog function block used. Each type has its own specific parameters and operating mode as shown in the table below.

Type of Function Block	Description
<pre> IB ≤ Ref A1 Analog1 ☐ Ref=4.9V </pre>	Contact A1 is closed when the value of analog input IB does not exceed the reference voltage entered in the Ref. field, 4.9 V in this example.
<pre> IB ≥ Ref A1 Analog2 ☐ Ref=4.9V </pre>	Contact A1 is closed when the value of analog input IB equals or exceeds the reference voltage entered in the Ref. field, 4.9 V in this example.
<pre> IC ≤ Ref A1 Analog3 ☐ Ref=4.9V </pre>	Contact A1 is closed when the value of analog input IC does not exceed the reference voltage entered in the Ref. field, 4.9 V in this example.
<pre> IC ≥ Ref A1 Analog4 ☐ Ref=4.9V </pre>	Contact A1 is closed when the value of analog input IC equals or exceeds the reference voltage entered in the Ref. field, 4.9 V in this example.
<pre> IB ≤ IC A1 Analog5 ☐ </pre>	Contact A1 is closed when the value of analog input IB does not exceed the value of analog input IC .
<pre> IB ≥ IC A1 Analog6 ☐ </pre>	Contact A1 is closed when the value of analog input IB equals or exceeds the value of analog input IC .
<pre> IC-H ≤ IB ≤ IC+H A1 Analog7 ☐ H=4.9V </pre>	Contact A1 is closed when the value of analog input IB is between IC-H and IC+H . H (the hysteresis) is entered in the H field, 4.9 V in this example.

The ☐ is used to lock the Analog function block. If this block is locked, the reference voltage or the hysteresis value (depending on the chosen type) no longer appears in the "**PARAMET.**" menu.

When the block is unlocked, the admissible values are between 0 and 9.9 Volts.

Chapter 5 - Contents





Entering Ladder Diagrams

This Chapter covers the following subjects:

1. Editor Environment	51
2. Element Entry Method	52
Entering a new element	52
Changing an element	52
Deleting an element	52
3. Link Entry Method	53
Entering links between elements	53
Deleting links between elements	53
Replacing a link with a contact	53
4. Function Block Parameter Entry Method	54
5. Deleting and Inserting Ladder Diagram Lines	55
Deleting a Ladder diagram line	55
Inserting a Ladder diagram line	55

1. Editor Environment

A Ladder diagram is entered into the smart relay using the front panel keys. The key functions are listed in the table below:

Key	Description
	Press this key to delete an element or a Ladder diagram line.
	Press this key to insert a Ladder diagram line.
	Press this key to: <ul style="list-style-type: none"> - Make a selection, - Edit an element's parameter page, - Edit a display page, - Validate a selection made. For example, when a blinking ■ is displayed while entering a diagram, pressing this key will call-up the "selection" mode used to choose the required contact or coil.
	Press this key to exit the current screen after making the required changes or to cancel the current Ladder diagram entry. For example, after changing a function block's parameters, press this key to return to diagram entry mode.
	When entering a diagram, using the arrow key pad lets the user move from one element to another using the Z4 and Z2 keys, and then changing the element's value using the Z1 and Z3 keys.

In the remainder of this Chapter, these keys will be referred to as **Del.**, **Ins. Line**, **Sel./ OK**, **Esc.**, **Z1**, **Z2**, **Z3** and **Z4**.

2. Element Entry Method

Entering a new element

It is only possible to position an element (contact or coil) when the blinking cursor ■ is displayed on screen. Contact entry is performed in the three left hand columns, coils can only be entered into the last column.

Entering a contact

- 1- Place the ■ blinking cursor in the required position.
- 2- Press **Sel./ OK**.
- 3- Choose the required element using the **Z1** and **Z3** keys.
- 4- Use the **Z2** key to call-up the number.
- 5- Choose the number using keys **Z1** and **Z3**.
- 6- Press **Sel./ OK** or **Z2** to validate.

Entering a coil

- 1- Place the ■ blinking cursor in the required position.
- 2- Press **Sel./ OK**.
- 3- Choose the required element using the **Z1** and **Z3** keys.
- 4- Use the **Z2** key to call-up the number.
- 5- Choose the number using keys **Z1** and **Z3**.
- 6- Use the **Z2** key to move to the type of coil.
- 7- Choose the type of coil using keys **Z1** and **Z3**.
- 8- Press **Sel./ OK** to validate.

Validating certain function block coils will bring-up a block parameter setting screen. For information on parameter characteristics, refer to Chapter 4, page 30. For information on the data entry methodology, refer to Sub-section 4, page 54 in the current chapter.

Changing an element

To change an element in an existing Ladder diagram, simply move to the element to change and follow the same procedure as when entering a new element.

Deleting an element

To delete an element, simply place the ■ cursor on the required element, then press **Del**. Generally, the deleted element must be replaced by a link.

3. Link Entry Method

Entering links between elements

In most cases, links are automatically entered by the smart relay. However, to enter a link manually, proceed as follows.

Links can only be entered when the ● blinking cursor is displayed.

- 1- Place the ● blinking cursor at the desired location.
- 2- Press **Sel./ OK** to start the link ("+" cursor).
- 3- Move the cursor to the desired location using the **Z1, Z2, Z3** or **Z4** keys.
- 4- Press **Sel./ OK** to validate. The link is drawn.

Repeat this action as many times as necessary to link the elements together as required.

Deleting links between elements

To delete a link, simply move the ● or ■ cursor onto the link to delete and press **Del**.

Replacing a link with a contact

To replace a link with a contact, simply place the ■ cursor at the required location and enter the contact as described on the previous page.

4. Function Block Parameter Entry Method

When entering a Ladder diagram, the function block parameters must be filled in. These parameter setting screens are displayed for:

Entering a Clock function block,
An Analog function block,
A command input to a Timer function block,
A count input to a Counter function block.

Regardless which screen is displayed, the parameter setting principle is the same:

- 1-Use the **Z4** and **Z2** keys to move the **■** cursor onto the parameter to change.
- 2-Select the parameter by pressing **Sel./ OK**.
- 3-Change the parameter value using the **Z1**, **Z2**, **Z3** and **Z4** keys.
- 4-Finish data entry by pressing **Esc.** to return to Ladder diagram entry.

5. Deleting and Inserting Ladder Diagram Lines

Deleting a Ladder diagram line

Ladder diagram lines are deleted line by line. Proceed as follows:

- 1- Move the cursor to a blank space in the line (where there are no links or elements), if necessary, delete an element to create the necessary blank space.
- 2- Press **Del**.
- 3- A delete validation menu is brought up. Select the appropriate choice using the **Z1** and **Z3** keys.
- 4- Validate the choice by pressing **Sel./ OK**.

The line is deleted.

Note: It is possible to delete all of the Ladder diagram lines stored in a smart relay. To do this, call up the "CLEAR PROG" option in the main menu and validate the deletion of all Ladder diagram lines.

Inserting a Ladder diagram line

To insert a Ladder diagram line, simply move to the line immediately above the one to create and press **Ins. Line**.

Chapter 6 - Contents

Debugging

This Chapter covers the following subjects:

1. Introduction	57
2. Dynamic Mode Ladder Diagrams	58
Displaying Ladder diagrams	58
Changing Ladder diagrams	58
Using Z keys as push buttons	58
3. Dynamic Mode Function Block Parameters	59
Displaying function block parameters	59
Changing function block parameters	60
4. Dynamic Mode Menus	61

1. Introduction

Once an application has been entered in Ladder diagram form, debugging tests still remain to be run.

The first step is to set the smart relay to RUN. To do this, select the "**RUN/STOP**" option from the main menu and validate the RUN mode selection.

From this moment on, the smart relay handles the physical inputs and outputs according to the instructions entered in the Ladder diagram.

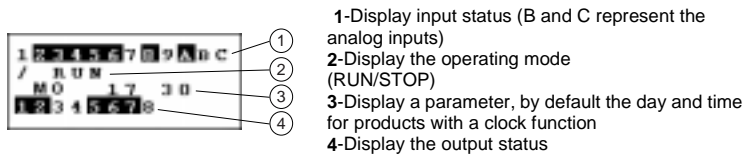

When inputs or outputs are active, they appear in reverse video mode (using black on a white background).

From this moment on, the term "dynamic operation" refers to the use of smart relay functions. In this publication, the terms RUN and dynamic have a similar meaning.

2. Dynamic Mode Ladder diagrams

Displaying Ladder diagrams

The smart relay can dynamically display the performance of a Ladder diagram. To do so, simply call up the "PROGRAM" option and select the lines to display using the cursor key pad.

Each closed contact or energized coil is displayed in reverse video mode (using white on a black background).



To change smart relay performance, the user can change or display some of the function block parameters.

Changing Ladder diagrams

Note: It is **ABSOLUTELY IMPOSIBLE** to change Ladder diagram lines in RUN mode.

It is however possible to change function block parameters.

In RUN, the Del. and Ins. Line keys are not available.
The Sel/Ok key is only usable for function blocks.

Using Z keys as push buttons

When the menus are called up, the Z keys can no longer be used as pushbuttons. To test the Ladder diagram in dynamic mode and observe the effect of the Z keys, the user must:

- 1- Display the Ladder diagram (see below).
- 2- Press the **Sel/OK** key.

To disable pushbutton mode operation, simply press the **Esc** key.

3. Dynamic Mode Function Block Parameters

Displaying function block parameters

In RUN mode, new functions are offered. It is therefore possible to display function block parameters.

The following elements can be displayed:

- 1- The current value and preset value of a Counter.
- 2- The status of Counter inputs and outputs.
- 3- The current value and preset value of a Timer.
- 4- All of the parameters of a Clock function block.
- 5- The reference voltage for an Analog function block.
- 6- The hysteresis value for an Analog function block.
- 7- The values measured on the analog inputs.

To do this, simply call up the "**PROGRAM.**" option and select the required function block, then press **Sel./ OK**.

A new screen is brought up with the function block's parameters. The procedure is the same as the one used to change function block parameters.

Screen example:

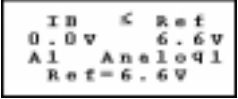
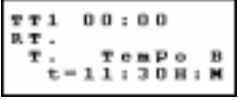
Screen	Parameters that can be displayed
	<ul style="list-style-type: none"> Counter contact state Counter coil state Current counter value Counter preset value
	<ul style="list-style-type: none"> Compared voltage level values Reference value Type of Analog function block
	<ul style="list-style-type: none"> Timer contact state Timer time out Preset duration value

3. Dynamic Mode Function Block Parameters

Changing function block parameters

In RUN mode a Counter preset value can be changed dynamically if it is not locked.

The following actions are allowed:

- 1- Changing a Counter preset value.
- 2- Changing a Timer preset value.
- 3- Changing Clock function block parameters.
- 3- Changing the reference voltage for an Analog function block.
- 4- Changing the hysteresis value for an Analog function block.

To do this, the simplest way is to:

- 1- Select "**PARAMET.**" from the main menu,
- 2- Press **Sel./ OK**,
- 3- Choose the required parameter using the **Z1** and **Z3** keys,
- 4- Press **Sel./ OK**,
- 5- Modify the parameter value using the **Z2**, **Z3** and **Z2**, **Z4** keys,
- 6- Validate by pressing **Sel./ OK**.

It is also possible to change a parameter value by selecting the "**PROGRAM**" function, and then selecting the required function block by pressing **Sel./ OK**.

4. Dynamic Mode Menus

Some menus are accessible in RUN mode, while others are not. Here is a summary table.

Menu	Access in STOP mode	Access in RUN mode
TIME SET	Yes	Yes
PROGRAM.	Yes	Yes*
PARAMET.	Yes	Yes
VISU.	Yes	Yes
RUN/STOP	Yes	Yes
CONFIG.	Yes	Yes
CLEAR PROG	Yes	No
TRANSFER.	Yes	No
PROG. INFO.	Yes	Yes
Configuration menu		
PASSWORD	Yes	Yes
LANGUAGE	Yes	Yes
Enter	Yes	No
Zx=KEYS	Yes	No
HELP	Yes	Yes

* Some functions are accessible, others not. Refer to the previous Sub-sections

Chapter 7 - Contents

Application Example

This Chapter covers the following subjects:

1. Specifications	63
2. Specification Analysis	64
3. Implementing the solution	65
Implementing the Ladder diagram	65
Setting function block parameters	66

1. Specifications

To enhance and centralize the control system in the underground car park of an administrative building. The vehicle entrance and exit to and from the car park are controlled by a typical automatic barrier that handles the normal standard functions such as opening and closing time delays to allow vehicles to pass, processing payment tickets, a built-in security interphone, external barrier locking in the closed position...

In addition, the new specification calls for adding a function to count the number of vehicles in the car park and control a light up display informing users that all of the parking spaces are taken and stopping new entries by locking the barrier in the closed position. Drivers then know to look for a parking space elsewhere. It must also be possible to override this function when it is necessary to allow the emergency services to intervene (fire department, doctors...).

The specification also calls for being able to inhibit access to the car park lot outside of working hours and to allow the security personnel to override this function for exceptional events. The normal working hours are: Monday to Friday, from 08:30 to 17:00, Saturday, from 09:30 to 12:00 and complete closure on Sundays.

For safety reasons, it is also necessary to exhaust toxic emissions such as CO₂ using a fan when the concentration levels measured exceed permissible levels (using a dedicated sensor that provides an output value between 0 and 10 V).

There is also a requirement to control lighting triggered by a vehicle arriving and through push button switches placed near all of the pedestrian access points. For power saving reasons, the lighting will be switched off after a delay of ten minutes, normally providing enough time for a user to park, leave their vehicle and take the elevator or to return to their vehicle and leave the parking lot.

To complement this system, manual intervention should allow updating the number of vehicles in the car park by incrementing or decrementing the number of vehicles as determined by the smart relay.

2. Specification Analysis

Smart relay label	Description
Input I1	Vehicle entry detection.
Input I2	Vehicle exit detection.
Counter C1	Counting the number of vehicles in the car park (93 maximum).
Output Q1	Car park full indicator
Output Q2	Entry barrier locking (inhibits entry barrier opening) when the car park is full or outside of office hours.
Function key Z4	Manual entry release.
Function key Z2	Resume automatic entry control.
Function key Z1	Manual incrementation of the number of vehicles in the car park.
Function key Z3	Manual decrementation of the number of vehicles in the car park.
Clock function block N°1	Managing car park access hours.
Inputs I3 and I4	Pushbuttons at pedestrian access points used to light car park lighting. One for the elevator and one for the stairway (no pedestrian access is allowed via the vehicle entry).
Output Q3	Lighting control.
Timer function block N°1	Lighting timer (10 minutes).
Analog input IB	CO2 level sensor
Analog function block A1 , the authorized threshold value corresponds to 8.5 Volts.	Comparison of the CO2 measurement with the authorized threshold.
Output Q4	Polluted air extraction fan control.
Timer function block N°2	Fan timer (15 minutes).

Note: To implement this solution, a smart relay with analog inputs, Clock function blocks and at least 4 discrete inputs and outputs is required. The ideal smart relay is an SR1 B 12 1 BD.

3. Implementing the Solution

Implementing the Ladder diagram

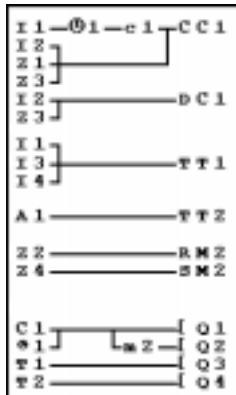

Counting vehicles in, subtracting vehicles out and manually updating the number of vehicles actually in the car park.

Starting the lighting timer.

Starting the fan timer.

Handling manual release.





Controlling outputs: Car park full indicator, blocking the entry, lighting the car park and fan extraction.

Note: When upcounting and downcounting, the counter locks up when the car park becomes full (no spurious detection or counting actions take place if vehicles are allowed to enter in manual release mode). **IMPORTANT:** In a given counter, coils CC and DC must only appear once in a Ladder diagram.

In addition, output Q2 is triggered when entry into the car part is inhibited. This leads to the use of an auxiliary relay to manually lock or unlock the access barrier using the cursor keys.

3. Implementing the Solution

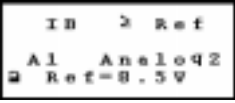
Setting function block parameters

Function block	Comments
<p>Counter function block C1</p>  <p>The screenshot shows a ladder logic diagram for counter block C1. It includes a normally open contact labeled 'CC1', a coil labeled 'RC.', and a timer coil labeled 'C'. Below the diagram, the parameter 'P=0093' is displayed.</p>	<p>The preset value is 93 (the maximum number of vehicles allowed in this car park). Where necessary, this value can be changed during operation.</p>
<p>Clock function block ⌚1</p>  <p>The first screenshot shows the configuration for Monday to Friday: 'MO 19:01', 'LU-VE', 'ON 08:30', and 'OFF 17:30'. The second screenshot shows the configuration for Saturday and Sunday: 'SA --', 'ON 09:30', and 'OFF 12:00'.</p>	<p>Opening hours: Monday to Friday from 08:30 to 17:30, Saturday from 09:30 to 12:00 and closed all day on Sunday. Two ranges are used.</p>
<p>Timer function block T1</p>  <p>The screenshot shows a ladder logic diagram for timer block T1 with a coil labeled 'RT.' and a timer coil labeled 'T.'. The parameter 't=10:00M:3' is displayed.</p>	<p>Car park lighting timer duration (10 minutes).</p>
<p>Analog function block A1</p>  <p>The screenshot shows the configuration for analog block A1 with the parameter 'Ref=8.5V'.</p>	<p>Comparison between the measured CO2 value and the threshold value (8.5 V).</p>
<p>Timer function block T2</p>  <p>The screenshot shows a ladder logic diagram for timer block T2 with a coil labeled 'RT.' and a timer coil labeled 'T.'. The parameter 't=15:00M:3' is displayed.</p>	<p>Fan operating duration if the CO2 threshold is exceeded.</p>

Chapter 8 - Contents

Troubleshooting

This Chapter covers the following subjects:

1. Smart Relay Messages	69
2. Frequently Asked Questions	70

1. Smart Relay Messages

Explanation of the messages returned by the smart relay. These messages generally indicate incompatible actions requested by the user.

Message	Cause	Corrective action
ERR. RUN MODE	The user requested access to a function that is only available when the smart relay is stopped.	Return to the main menu, select the "RUN/STOP" option, set the relay to STOP mode, then return to where the message occurred.
NO PARAMET.	The user requested access to the "PARAMET." option when no parameter is available (the diagram does not comprise any elements with parameters).	Go to the diagram to ensure that it was entered correctly and that it comprises elements with parameters that can be set: Counters, Timer, Time/Date functions, Analog function blocks.
NO PARAMET.	The user requested access to the "VISU." option when no element that can be displayed has been entered in the diagram.	Go to the diagram to ensure that the diagram was entered correctly and that it comprises at least one function block.
PROGRAM. INCOMPAT.	The user requested the transfer of a program that does not match the characteristics of the target smart relay, e.g. clocks are used when the target smart relay does not have any.	Check the origin of the program to transfer and choose a program that is compatible with the appropriate smart module.
TRANSF.ERR.	A transfer was in progress and the link with the PC went down unexpectedly.	Refer to the documentation for the smart relay PC programming application ZelioSoft .
TRANSF.ERR.	A transfer to the EEPROM was requested and the EEPROM is not present or incorrectly located.	Check for the presence and correct location of the EEPROM.

2. Frequently Asked Questions

To assist the user in understanding the smart relay, the table below details frequently asked questions.

Question	Answer
I cannot access some parameters	Some parameters are not accessible, refer to the documentation to determine whether these elements can be changed. Example of an element that cannot be changed: Counter function block counting direction. This element is only accessible by wiring in a diagram line.
I still cannot access some parameters	To access the parameters, use the Z4 and Z2 keys on the arrow key pad to select them (the Z1 and Z3 keys are only used to change their value). Then press Sel./ OK to change the selected element using the Z1 and Z3 keys.
When I try to change a parameter, the Z1 and Z3 keys on the arrow key pad do not work.	This is normal, to enter the modification mode, first press Sel./ OK (the parameter blinks). Then the Z1 and Z2 key become effective.
I cannot STOP my smart relay despite validating the RUN/ STOP option in the main menu using the Sel./ OK key.	BE SURE to correctly read the message text and confirm the correct option.
My Ladder diagram comprises 67 lines and it takes quite a long time to reach the last line. What can I do to speed things up?	To move around faster, simply press on the Z1 or Z3 keys on the arrow key pad for a longer time. You can then scroll 5 lines at a time.
I would like to change my diagram lines but the Sel./ OK key no longer works.	Ensure that the smart relay is indeed stopped. Changes in RUN mode are not allowed.
When I try to change my Ladder diagram lines, the smart relay shows me a blank screen, have I lost everything I did?	Not necessarily, this situation may occur if blank lines have been inserted at the start of the Ladder diagram. Press Z3 to check whether your program lines are not located further down.

2. Frequently Asked Questions

Question	Answer
<p>I have a Counter function block called C1 used in a Ladder diagram line to count and it downcounts on another line. Only the downcount function works. Why?</p>	<p>This is perfectly normal, a Counter's CC coil must appear once and once only in the Ladder diagram. To understand the method, refer to the example in Chapter 7.</p>
<p>I have forgotten my password and I can no longer access my smart relay functions. What can I do?</p>	<p>To delete a password, move to the password entry screen and type the following key sequence: Z1, Z4, Z3, Z2.</p>
<p>I have a Ladder diagram that uses a Z key as a push button. I would like to test it but when I display the Ladder diagram in on-line mode, the Z key is no longer operational. What can I do?</p>	<p>To use the Z keys as push buttons when displaying a ladder diagram in real-time mode, simply press Sel.OK when displaying the diagram. To disable the push button mode, simply press Esc.</p>
<p>I generated a Ladder diagram on a module with a clock function, can I transfer to the EEPROM in a module without a clock?</p>	<p>Yes this is possible if your Ladder diagram does not use Clock function blocks.</p>
<p>When entering a Ladder diagram, the clock function blocks do not appear when choosing the contacts. Is this normal?</p>	<p>It is highly probable that the module is one not fitted with a clock and as a result, the clock function blocks cannot be accessed. Check the product reference number.</p>
<p>When entering a Ladder diagram, the analog function blocks do not appear when choosing the contacts. Is this normal?</p>	<p>It is highly probable that the module does not have any analog inputs and as a result the analog function blocks cannot be accessed. Check the product reference number.</p>

Chapter 9 - Contents

Transferring Ladder Diagrams

This Chapter covers the following subjects:

1. How to Transfer an Application	73
Smart relay -> PC Transfer	73
PC -> Smart relay transfer	73
Smart relay -> EEPROM transfer	74
EEPROM -> Smart relay transfer	74

1. How to Transfer an Application

Smart relay -> PC transfer

The Zelio smart relay can be configured and programmed using the ZelioSoft program. This transfer function lets the user retrieve an application from a smart relay using the program.

The following method is used:

- 1- Select the "**TRANSFER.**" function from the main menu.
- 2- Press the **Sel./ OK** key to validate.
- 3- Select the "**Modul.->PC**" function.
- 4- Press the **Sel./ OK** key to validate.
- 5- Enter the password if necessary.
- 6- The smart module displays "**READY**", and the transfer is performed as soon as the program is ready.

PC -> Smart relay transfer

This transfer function is used to load an application developed using ZelioSoft into a smart relay.

The following method is used:

- 1- Select the "**TRANSFER.**" function from the main menu.
- 2- Press the **Sel./ OK** key to validate.
- 3- Select the "**PC->Modul.**" function.
- 4- Press the **Sel./ OK** key to validate.
- 5- When prompted to "**Change Prog?'**", select the answer "**YES**" by pressing the **Z1** key.
- 6- Press the **Sel./ OK** key to validate.
- 7- The smart relay displays "**READY**", the transfer is performed as soon as the software requests it.

1. How to Transfer an Application

Smart relay -> EEPROM transfer

The smart relay has an optional EEPROM. This function lets the user load the application in the Zelio smart relay into the EEPROM.

The following method is used:

- 1- Select the "**TRANSFER.**" function from the main menu.
- 2- Press the **Sel./ OK** key to validate.
- 3- Select the "**Modul.->Mem**" function.
- 4- Press the **Sel./ OK** key to validate.
- 5- Enter the password if necessary.
- 6- The smart relay displays "**Modul. >>>**" then "**TRANSFER OK**", the transfer is done.

Note: The EEPROM can then be used to load an application into another smart relay.

EEPROM -> Smart relay transfer

This transfer is used to reload an application into a Zelio smart relay. It avoids the need to re-enter an existing application.

The following method is used:











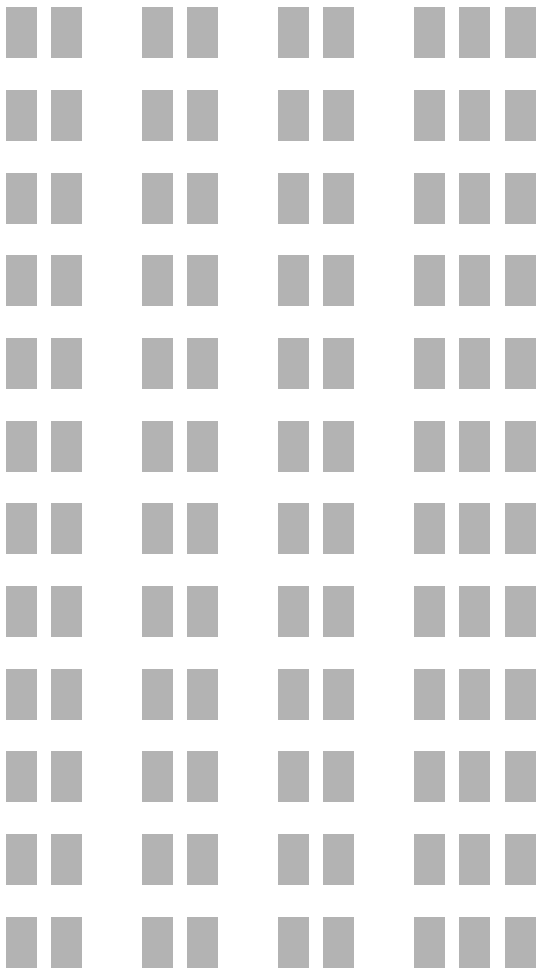

- 1- Select the "**TRANSFER.**" function from the main menu.
- 2- Press the **Sel./ OK** key to validate.
- 3- Select the "**Mem->Modul.**" function.
- 4- Press the **Sel./ OK** key to validate.
- 5- When prompted to "**Change Prog?**", select the answer "**YES**" by pressing the **Z1** key.
- 6- Press the **Sel./ OK** key to validate.
- 7- The smart relay displays "**>>> Modul.**" then "**TRANSFER OK**", the transfer is done.

Appendix - Contents

This Chapter covers the following subjects:

1. Forms	77
Clock function block	78
Counter function block	78
Timer function block	78
Analog function block	79
Arrow keys	79
User's quick reference	79



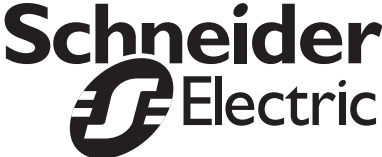





1. Forms

	_____
	_____
	_____
	_____
	_____
	_____
	_____
	_____
	_____
	_____
	_____
	_____
LADDER DIAGRAM	Application: _____
	Date: _____ Version: _____
	Comments: _____









	Title page: _____

1. Forms









Clock function block

 ABCD 	 ABCD 	 ABCD 	 ABCD 
-	-	-	-
ON:	ON:	ON:	ON:
OFF:	OFF:	OFF:	OFF:

Counter function block

C 	C 	C 	C 
<input type="text"/>	<input type="text"/>	<input type="text"/>	<input type="text"/>
DC 	DC 	DC 	DC 

Timer function block

T 	T 	T 	T 
<input type="text"/>	<input type="text"/>	<input type="text"/>	<input type="text"/>
Type 	Type 	Type 	Type 

1. Forms

Analog function block

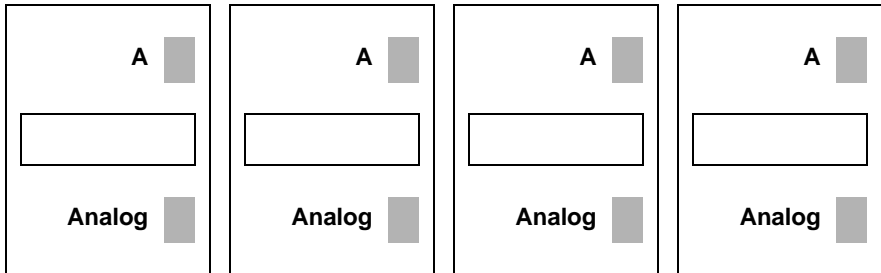

Arrow keys

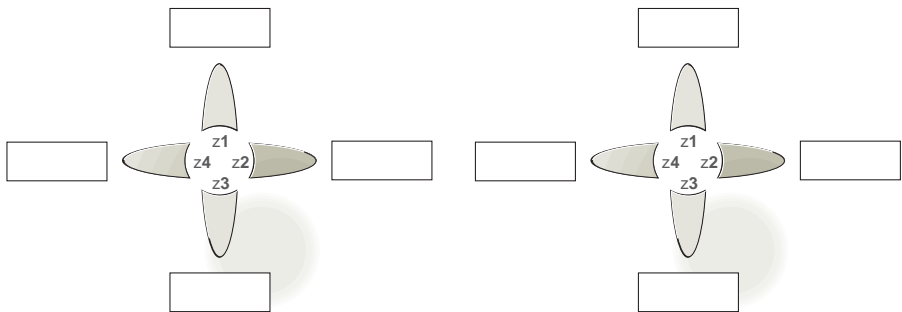

User's quick reference

Reminder - Parameter display

To display parameters, press **Sel./ OK** to bring up the "PARAMET." menu, then scroll the parameters using the **Z1** and **Z3** keys.

Reminder - Changing parameters

To change the parameters, simply move to the required parameter in the "PARAMET." menu, press **Sel./ OK**, then change the parameter.

Reminder - Using the display screen

To monitor the state of an element on the main screen in real-time: Bring up the "VISU." menu, move to the element to display, then validate the selection by pressing **Sel./ OK**. Return to the main screen by pressing **Esc**.

Index

A

- Analog
 - contact 47
 - parameters 48
- Auxiliary relay 35

C

- Calibrated pulse 45
- Clock
 - contact 37
 - enter 39
 - operation 37
 - number 37
 - parameters 38
 - summary 40
- Coil
 - counter 41
 - enter 52
 - output 33
 - remote control relay 33, 34
 - RESET 33, 34
 - SET 33, 34

Coils

- timer 43

- Configuration
 - menu 10, 11

- Connection
 - PC 3
 - discrete 5

- Contact
 - analog 47
 - clock 37
 - counter 41
 - entering 52
 - input 32
 - output 33
 - timer 43

- Counter
 - contact 41
 - decrementing 42
 - incrementing 42
 - number 41
 - parameters 41
 - preset 42
 - reset 42

D

- Date
 - modify 8, 10
- Debugging 57

- Delete
 - element 6
 - Ladder diagram 10
 - line 6
 - program 10

- Diagnostic 69
- Display 3
 - menu 10

E

- EEPROM
 - location 3
 - transfer 10
- Electrical diagram
 - notation 16
- ERR. RUN MODE 69
- Example
 - specifications 63

F

- Fast input
 - menu 11
- Filtering 27
- Function
 - Init. 26
- Function block
 - analog 47
 - clock 37
 - counter 41
 - timer 43

H

- Help
 - automatic 29
 - menu 10, 11
- Hysteresis 48

I

- Ib 48
- Ic 48
- Ini. 7
- Inputs
 - analog 3, 4, 48
 - connection 5
 - contact 32
 - current 4
 - discrete 4, 32
 - display 3, 57
 - fast 27
 - filtering 11
 - number 4, 32
 - voltage 4
- Insert line 6

K

Key

- arrow 3
- delete 3, 6
- escape 3, 6
- insert 3, 6
- pushbutton 3, 58
- selection 3, 6
- Z 36, 58

Keys

- contact 28
- menu 11
- Z 28

L

Label 3

Language

- choice 7
- menu 11
- modifying 26
- number 26

Link

- entering 53
- Lock 29

M

Main menu

- access 6
- description 9

Menu

- in RUN mode 61

Messages 69

Modify

- field 8
- element value 8

Mounting 3

N

NO PARAMET. 69

O

Operating ranges 38

Outputs

- coil 33
- contact 33
- discrete 33
- number 4, 33
- relay 4

P

Parameters

- analog 48

display 3, 57

Clock function block 38

counter 41

display in RUN mode 59

enter 54

menu 10

modify 60

timer 43

Password

cancel 25

effect 25

enter 25

menu 11

modify 25

Power supply

general 3

value 4

Preset

counter 42

timer 44

PROGRAM. INCOMPAT. 69

Program

menu 10

Q

Questions (FAQ) 70

R

Remote control relay 33

RUN

displaying 3, 57

menu 10

setting to RUN 21

S

Symmetrical blinker 45

Ladder diagram

delete 55

display in RUN mode 58

entry 18

example 65

insert 55

nbr. of lines 31

notation 16

operation 13

STOP

menu 10

set to 21

T

Terminal block

- inputs 3

- outputs 3

Time

- modifying 8

Time base

- timer 44

Time out

- idle 45

- working 45

Timer

- command 44

- contact 43

- number of 43

- parameters 43

- preset 44

- reset 44

- time base 44

- type 44, 45

- Total 45

TRANSF.ERR 69

Transfer

- EEPROM 10, 74

- PC 10, 73

Two-way switch

- enter 18

V

Validate 6

Z

Z keys

- display 3

The products, equipment and services presented in this document are subject to change in their presentation, operating or usage characteristics. Their description cannot be considered contractually binding.

© Copyright Telemecanique 2000. All rights reserved. This document may not be reproduced or copied, in whole or in part, in any form or by any means, graphic, electronic, mechanical or other, including photocopying, recording or storage in a retrieval system.