

SOLJET PRO III

XJ-740
XJ-640 USER'S MANUAL
XJ-540

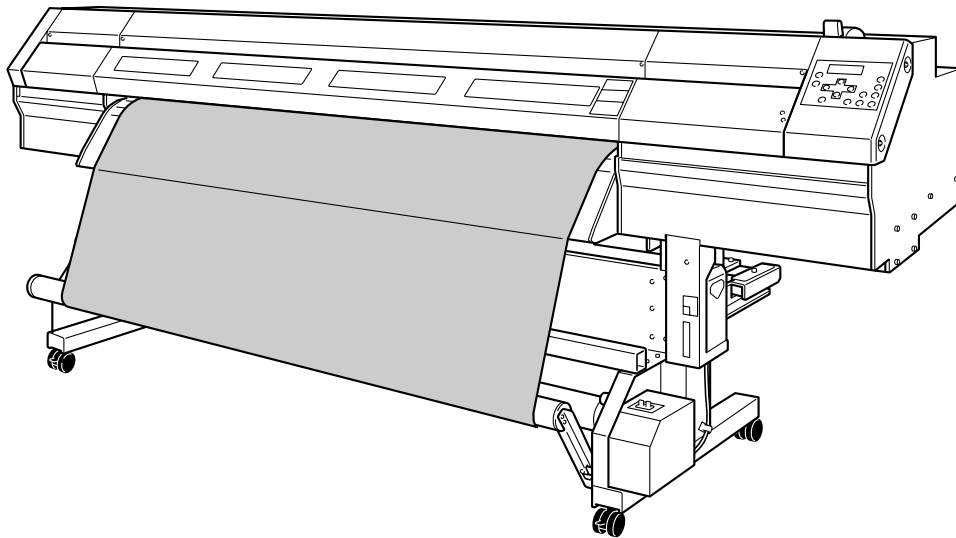

Thank you very much for purchasing this product.

- To ensure correct and safe usage with a full understanding of this product's performance, please be sure to read through this manual completely and store it in a safe location.
 - Unauthorized copying or transferral of this manual, in whole or in part, is prohibited.
 - The contents of this document and the specifications of this product are subject to change without notice.
 - The documentation and the product have been prepared and tested as much as possible. If you find any misprint or error, please inform us.
 - Roland DG Corp. assumes no responsibility for any direct or indirect loss or damage which may occur through use of this product, regardless of any failure to perform on the part of this product.
 - Roland DG Corp. assumes no responsibility for any direct or indirect loss or damage which may occur with respect to any article made using this product.
-

For the USA

**FEDERAL COMMUNICATIONS COMMISSION
RADIO FREQUENCY INTERFERENCE
STATEMENT**

This equipment has been tested and found to comply with the limits for a Class A digital device, pursuant to Part 15 of the FCC Rules.

These limits are designed to provide reasonable protection against harmful interference when the equipment is operated in a commercial environment.

This equipment generates, uses, and can radiate radio frequency energy and, if not installed and used in accordance with the instruction manual, may cause harmful interference to radio communications.

Operation of this equipment in a residential area is likely to cause harmful interference in which case the user will be required to correct the interference at his own expense.

Unauthorized changes or modification to this system can void the users authority to operate this equipment.

NOTICE

Grounding Instructions

Do not modify the plug provided—if it will not fit the outlet, have the proper outlet installed by a qualified electrician.

Check with qualified electrician or service personnel if the grounding instructions are not completely understood, or if in doubt as to whether the tool is properly grounded.

Use only 3-wire extension cords that have 3-prong grounding plugs and 3-pole receptacles that accept the tool's plug.

Repair or replace damaged or worn out cord immediately.

For Canada

CLASS A NOTICE

This Class A digital apparatus meets all requirements of the Canadian Interference-Causing Equipment Regulations.

CLASSE A AVIS

Cet appareil numérique de la classe A respecte toutes les exigences du Règlement sur le matériel brouilleur du Canada.

WARNING

This is a Class A product. In a domestic environment this product may cause radio interference in which case the user may be required to take adequate measures.



About the GPL/LGPL software used in this product

Thank you for purchasing our product.

This product is using GNU General Public License (GPL) / GNU Lesser General Public License (LGPL) software. You have the right to acquire, modify, and distribute the source code for this GPL/LGPL software. You can obtain the GPL/LGPL source code used in this product by downloading it from the following website.

URL: <http://www.rolanddg.com/gpl/>

Contents

 To Ensure Safe Use	4
 Pour utiliser en toute sécurité	11
Important Notes on Handling and Use	18
Printer unit	18
Ink cartridges	18
Chapter 1 Introduction	19
1-1 Features of the Machine	20
1-2 Part Names and Functions	21
Printer Unit	21
Operation Panel	23
Media Take-up System	24
Chapter 2 Basic Operation	25
2-1 Switching the Power On and Off	26
Switching the Power On and Off	26
The Power-saving Feature	27
2-2 Loading and Cutting Off Media	28
Usable Media	28
Loading Media	28
How to Cut Off Media	33
2-3 Settings for the Media Heating System	34
What Is the Media Heating System?	34
Making the Temperature Setting for the Media Heating System	34
General Guide for the Preset Temperatures	35
2-4 Starting Printing	36
Getting Ready to Receive Data from a Computer	36
Printing Tests and Cleaning	37
2-5 If Ink Runs Out	39
Checking for Remaining Ink	39
When Ink Cartridges Become Empty	40
Chapter 3 Operation of the Media Take-up System	43
3-1 The Take-up System	44
Features of the Take-up System	44
Operating Conditions for the Take-up System	44
3-2 Using the Take-up System	45
Loading Roll Media	45
Removing Taken-up Media	48
Chapter 4 Maintenance and Adjustment	49
4-1 Daily Care and Maintenance	50
Disposing of Discharged Ink	50
Cleaning	52
Care and Maintenance of the Print Heads	53
4-2 When Head Cleaning Is Not Effective	54
Performing More Powerful Cleaning	54
When Powerful Cleaning Is Not Effective	55
4-3 Cleaning the Heads Using the Cleaning Kit	56
When the Cleaning Kit Becomes Necessary	56
How to Perform Cleaning	56
4-4 Replacing Consumable Parts	60

Replacing the Wipers	60
Replacing the Separating Knife	62
4-5 When Not in Use for a Prolonged Period	64
Keep Performing Maintenance	64
Alarm Feature	64
Important Note on Draining Ink	64
4-6 When Moving the Unit	65
Procedures from Preparing to Move Through Reinstalling	65
Chapter 5 Feature Reference	67
5-1 Pausing or Canceling Printing	68
Canceling Printing Before It Finishes	68
5-2 Setting the Printing Position and Margins	69
Shifting the Print-start Position Forward or Backward	69
Shifting the Printing Position to the Left	69
Expanding the Printing Area by Reducing the Margins	70
5-3 Accommodating Various Kinds of Media	71
Using Transparent Media	71
Printing Hard-to-dry Media	73
Preventing Media from Coming Loose	73
Speeding Up Printing for Narrow Media	74
Preventing Soiling of the Media and Dot Drop-out During Printing	74
Using Sticky Media	75
How to Load Sheet Media	76
5-4 Setting How the Printer Operates	77
Determining What Happens When an Ink Cartridge Is Empty	77
Changing the Type of Ink	77
Setting the Interval until Activation of the Sleep Mode	78
Deactivating the Sleep Mode	78
Giving Priority Efficient Ink Use During Operation	78
Changing the Menu Language and the Units of Measurement	79
Returning All Settings to Their Initial Values	80
5-5 Optimizing Printing to Match Media Thickness	81
Adjusting Head Height to Match Media Thickness	81
Correcting for Misalignment in Bidirectional Printing	82
Correcting for Misalignment in Bidirectional Printing More Precisely	83
Performing Feed Correction to Alleviate Horizontal Bands and the Like	85
Changing the Feed-correction Value During Printing	86
5-6 Changing the Ink-drying Method	87
Switching Off the Preheater, Print Heater, or Dryer	87
Determining How the Media Heating System Operates	87
Drying the Trailing Edge of the Printing Area on the Dryer	88
5-7 Setting How the Auxiliary Drying Unit Operates	89
Switching the Drying-heater Unit On and Off	89
Switching the Blower-fan Unit On and Off	89
5-8 Saving the Printer Settings to Match the Media	90
Saving Optimized Media Settings As Preset Values	90
Loading a Saved Preset	91
Assigning a Name to a Preset	91
5-9 Making the Network Settings	92
Setting the IP Address, Subnet Mask, Etc.	92
5-10 Viewing Information about the Media and the System	93
Displaying the Amount of Media Remaining	93
Verifying the Setting for the Amount Remaining Every Time the Media Is Changed	93
Printing the Amount of Remaining Media	94
Printing a System Report	94

Viewing the Serial Number, Firmware Version, and Other Information	95
Viewing the Network Settings	95
5-11 Performing Maintenance	96
Draining Ink and Performing Internal Washing	96
Draining Ink Remaining Inside the Machine	96
5-12 Menu List	98
Main Menu	98
Language and Unit Menu	103
Cleaning Menu	103
Heater Configuration Menu	103
Chapter 6 What to Do If	105
6-1 The Machine Doesn't Run	106
The Printer Unit Doesn't Run	106
The Media Take-up System Doesn't Run	106
The Media Heating System Doesn't Warm Up	106
6-2 Attractive Printing Is Impossible	107
Printed Results Are Coarse or Contain Horizontal Stripes	107
Colors Are Unstable or Uneven	107
The Media Becomes Soiled When Printed	108
6-3 The Media Jams	109
The Media Jams	109
6-4 The Media Cannot Be Taken Up Smoothly	110
The Media Cannot Be Taken Up Smoothly	110
6-5 Media Wrinkles or Shrinks, or Feed Is Unstable	111
Media Wrinkles or Shrinks	111
Media Feed Is Not Straight	111
Media Feed Is Not Smooth	111
6-6 The Print Heads Stopped Moving	112
What to Do First	112
If the Heads Still Do Not Move	112
6-7 If a Message Appears	113
6-8 If an Error Message Appears	114
Chapter 7 Specifications	117
7-1 Usable Media	118
Conditions for Usable Media	118
7-2 Printing Area	119
Printing Area and Margins	119
Media-cutoff Location During Continuous Printing	120
7-3 Locations of the Power Rating and Serial Number Labels	121
7-4 Specifications	122

This document is the user's manual for the XJ-740, the XJ-640, and the XJ-540. Also, most of the figures in this document depict the XJ-740.

Company names and product names are trademarks or registered trademarks of their respective holders.

Copyright© 2007 Roland DG Corporation



<http://www.rolanddg.com/>





To Ensure Safe Use

Improper handling or operation of this machine may result in injury or damage to property. Points which must be observed to prevent such injury or damage are described as follows.

About WARNING and CAUTION Notices

 WARNING	Used for instructions intended to alert the user to the risk of death or severe injury should the unit be used improperly.
 CAUTION	Used for instructions intended to alert the user to the risk of injury or material damage should the unit be used improperly. * Material damage refers to damage or other adverse effects caused with respect to the home and all its furnishings, as well to domestic animals or pets.

About the Symbols

	The  symbol alerts the user to important instructions or warnings. The specific meaning of the symbol is determined by the design contained within the triangle. The symbol at left means "danger of electrocution."
	The  symbol alerts the user to items that must never be carried out (are forbidden). The specific thing that must not be done is indicated by the design contained within the circle. The symbol at left means the unit must never be disassembled.
	The  symbol alerts the user to things that must be carried out. The specific thing that must be done is indicated by the design contained within the circle. The symbol at left means the power-cord plug must be unplugged from the outlet.

 **Incorrect operation may cause injury**

 **WARNING**

 **Be sure to follow the operation procedures described in this documentation. Never allow anyone unfamiliar with the usage or handling of the machine to touch it.**
Incorrect usage or handling may lead to an accident.

 **Keep children away from the machine.**
The machine includes areas and components that pose a hazard to children and may result in injury, blindness, choking, or other serious accident.

 **Never operate the machine while tired or after ingesting alcohol or any medication.**
Operation requires unimpaired judgment. Impaired judgment may result in an accident.

 **Never use the machine for any purpose for which it is not intended, or use the machine in an undue manner that exceeds its capacity.**
Doing so may result in injury or fire.

 **For accessories (optional and consumable items, power cord, and the like), use only genuine articles compatible with this machine.**
Incompatible items may lead to an accident.

 **Before attempting cleaning, maintenance, or attachment or detachment of optional items, disconnect the power cord.**
Attempting such operations while the machine is connected to a power source may result in injury or electrical shock.

 **Never attempt to disassemble, repair, or modify the machine.**
Doing so may result in fire, electrical shock, or injury. Entrust repairs to a trained service technician.

 **CAUTION**

 **Exercise caution to avoid being pinched or becoming caught.**
Inadvertent contact with certain areas may cause the hand or fingers to be pinched or become caught. Use care when performing operations.

 **Never attempt operation while wearing a necktie, necklace, or loose clothing. Bind long hair securely.**
Such items may become caught in the machine, resulting in injury.

 **Conduct operations in a clean, brightly lit location.**
Working in a location that is dark or cluttered may lead to an accident, such as becoming caught in the machine as the result of an inadvertent stumble.

 **Never climb or lean on the machine.**
The machine is not made to support a person. Climbing or leaning on the machine may dislodge components and cause a slip or fall, resulting in injury.

 **Caution: cutting tool.**
This machine has an internal tool. To avoid injury, handle the tool with care.

⚠ Danger of electrical short, shock, electrocution, or fire

⚠ WARNING

! Connect to an electrical outlet that complies with this machine's ratings (for voltage, frequency, and current). Incorrect voltage or insufficient current may cause fire or electrical shock.

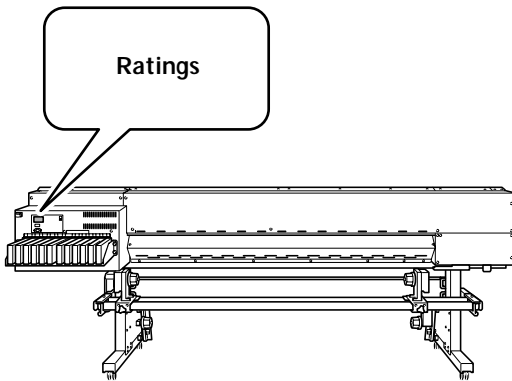

⊘ Never use out of doors or in any location where exposure to water or high humidity may occur. Never touch with wet hands. Doing so may result in fire or electrical shock.

⊘ Never allow any foreign object to get inside. Never expose to liquid spills. Inserting objects such as coins or matches or allowing beverages to be spilled into the ventilation ports may result in fire or electrical shock. If anything gets inside, immediately disconnect the power cord and contact your authorized Roland DG Corp. dealer.

⊘ Never place any flammable object nearby. Never use a combustible aerosol spray nearby. Never use in any location where gases can accumulate. Combustion or explosion may be a danger.

⚠ WARNING

! Handle the power cord, plug, and electrical outlet correctly and with care. Never use any article that is damaged. Using a damaged article may result in fire or electrical shock.

! When using an extension cord or power strip, use one that adequately satisfies the machine's ratings (for voltage, frequency, and current). Use of multiple electrical loads on a single electrical outlet or of a lengthy extension cord may cause fire.

⏚ Connect to ground. This can prevent fire or electrical shock due to current leakage in the event of malfunction.

! Position so that the power plug is within immediate reach at all times. This is to enable quick disconnection of the power plug in the event of an emergency. Install the machine next to an electrical outlet. Also, provide enough empty space to allow immediate access to the electrical outlet.

! If sparking, smoke, burning odor, unusual sound, or abnormal operation occurs, immediately unplug the power cord. Never use if any component is damaged. Continuing to use the machine may result in fire, electrical shock, or injury. Contact your authorized Roland DG Corp. dealer.

⚠ Important notes about the power cord, plug, and electrical outlet

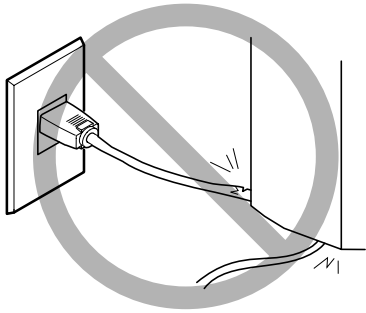

Never place any object on top or subject to damage.

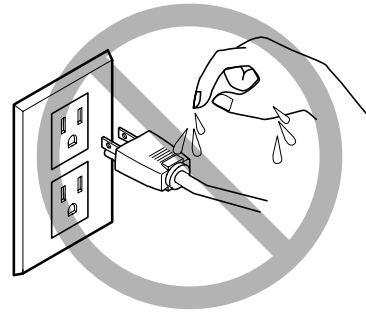

Never allow to get wet.

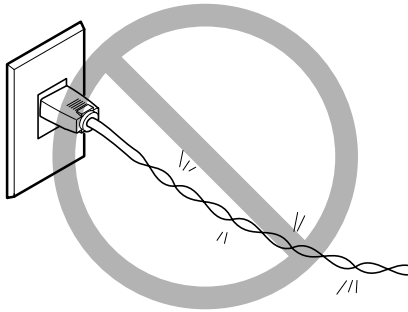

Never bend or twist with undue force.

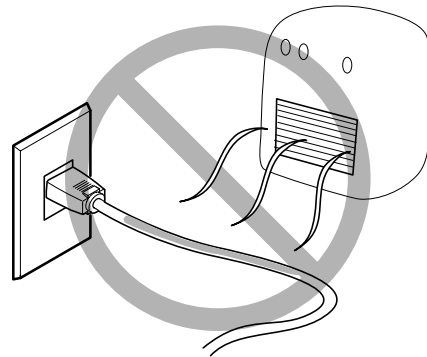

Never make hot.

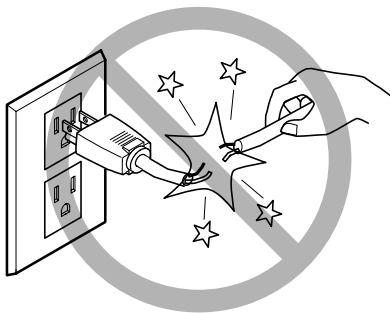

Never pull with undue force.

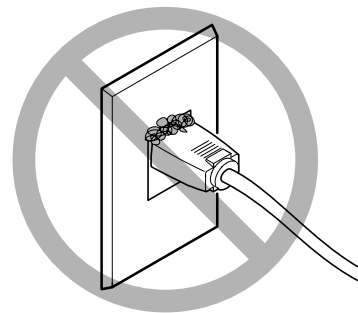

Dust may cause fire.

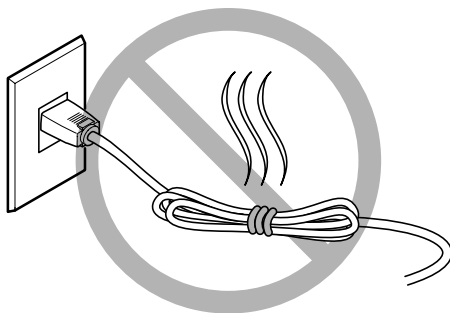

Never bundle, bind, or roll up.

 **Ink, cleaning fluid, and discharged fluid are flammable and toxic**

 **WARNING**

 **Keep open flame away from the work area.**
Ink and discharged fluid are flammable.

 **Never store ink, cleaning fluid, or discharged fluid in any of the following locations.**

- Any location exposed to open flame
- Any location where high temperature may occur
- Near bleach or any other such oxidizing agent or explosive material
- Any location within the reach of children

Fire may be a danger. Accidental ingestion by children may pose a health hazard.

 **Never place an ink cartridge in fire.**
Ink may flow out, catch fire, and spread fire to other nearby objects.

 **Never drink or sniff ink, cleaning fluid, or discharged fluid, or allow them to come in contact with the eyes or skin.**
Doing so may be hazardous to the health.

 **CAUTION**

 **Ensure adequate ventilation for the work area.**
Failing to perform ventilation may result in a health hazard or danger of combustion due to ink fumes.

 **Never allow an ink cartridge to be subjected to impact, and never attempt to disassemble.**
Ink may leak.

 **In the event of ingestion or physical distress**

- In the event of contact with the eyes, immediately flush with water for at least 15 minutes. If eye irritation continues, seek treatment by a physician.
- In the event of contact with skin, immediately wash with soap. If irritation or inflammation occurs, seek treatment by a physician.
- In the event of ingestion, do not induce vomiting, and immediately seek treatment by a physician. Forcibly inducing vomiting may lead to danger of choking.
- If odor leads to physical distress, move to a well-ventilated location and rest quietly. If dizziness or nausea persists, seek treatment by a physician.

 **This machine weighs 250 to 300 kg (550 to 660 lb.).
Media weighs 30 to 50 kg (66 to 110 lb.).**

 **WARNING**

 **Install the machine in a location that is level, stable, and able to bear the weight of the machine.**

The total weight of the machine may reach 300 kg (660 lb.) (280 kg (616 lb.) for the XJ-640, 250 kg (550 lb.) for the XJ-540) or more. Installation in an unsuitable location may cause a major accident, including tipover, fall, or collapse.

 **Unloading and emplacement are operations that must be performed by eight persons or more (by six persons or more for the XJ-540).**

Tasks that require undue effort when performed by a small number of persons may result in physical injury. Also, if dropped, such items may cause injury.

 **WARNING**

 **Be sure to lock the stand's casters.**
If the machine should begin to topple, a major accident may result, including crushing of the appendages or the body.

 **When storing roll media, implement adequate safety measures to ensure that the stored media will not roll, fall, or topple over.**

Danger exists of becoming pinned under the media and suffering serious injury.

 **Handling roll media is an operation that must be performed by two persons or more, and care must be taken to prevent falls.**

Attempting to lift heavy media in a manner that taxes your strength may cause physical injury. Also, if dropped, such items may cause injury.

 **Danger of fire, burns, or toxic gas emissions**

 **WARNING**

 **Caution: high temperatures.**
Areas such as the dryer become hot. Exercise caution to avoid fire or burns.

 **When printing is not being performed, remove any loaded media or switch off the power.**

The continued application of heat at a single location may cause the release of toxic gases from the media or pose a fire hazard.

 **WARNING**

 **Never use media that cannot withstand heat.**

Doing so may degrade the media, or may result in fire or the release of toxic gases.

⚠ Warning Labels

Warning labels are affixed to make areas of danger immediately clear. The meanings of these labels are as follows. Be sure to heed their warnings.

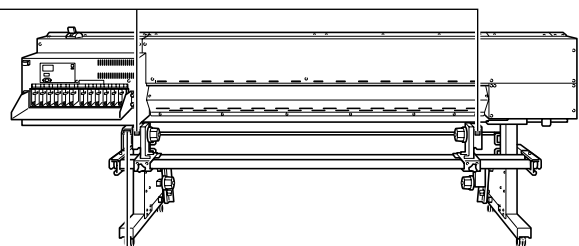
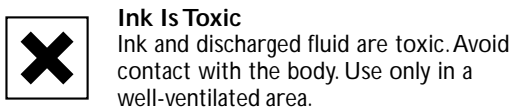
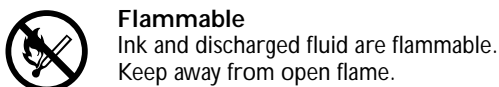
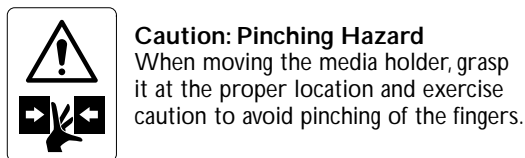
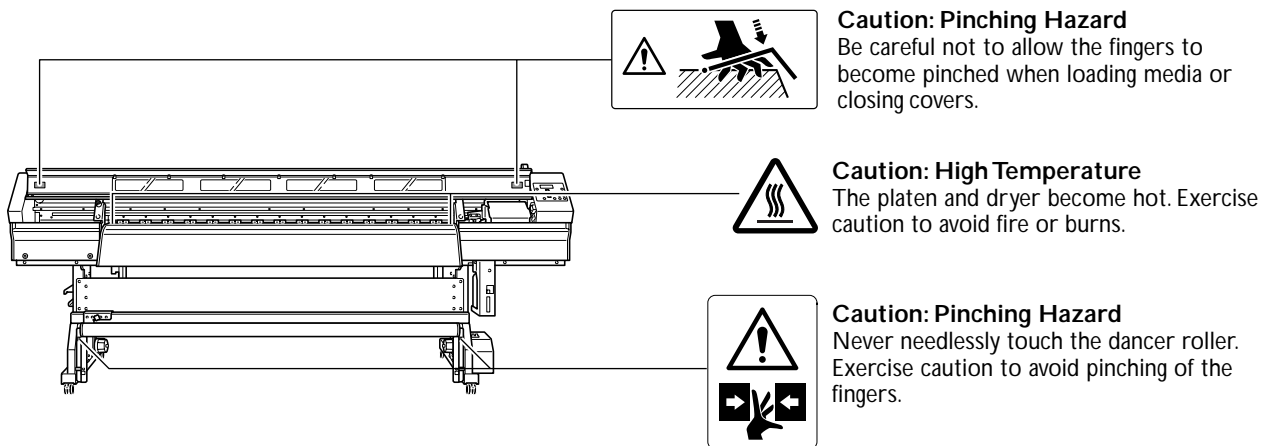
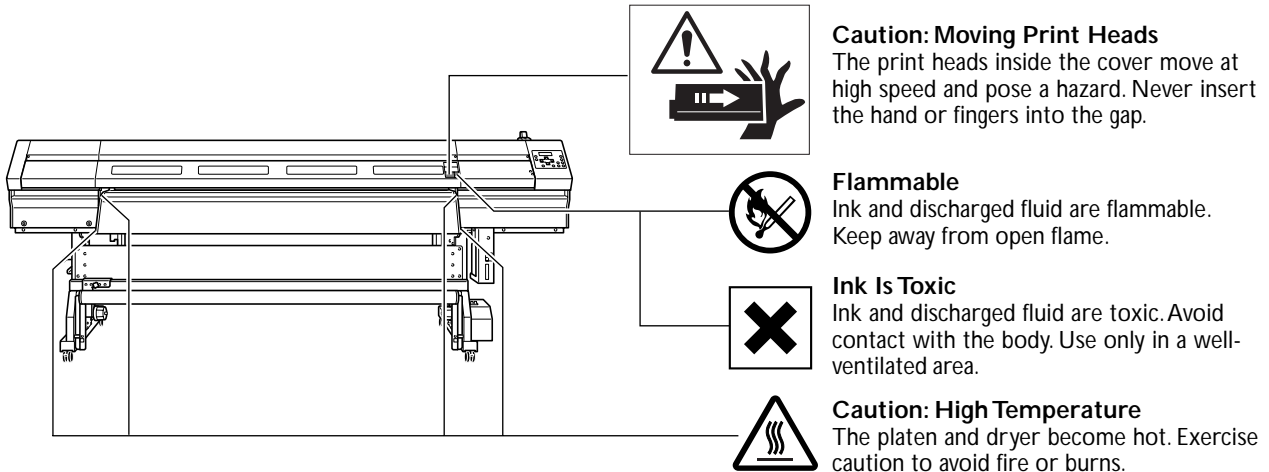

Also, never remove the labels or allow them to become obscured.





Pour utiliser en toute sécurité

La manipulation ou l'utilisation inadéquates de cet appareil peuvent causer des blessures ou des dommages matériels. Les précautions à prendre pour prévenir les blessures ou les dommages sont décrites ci-dessous.

Avis sur les avertissements

 ATTENTION	Utilisé pour avertir l'utilisateur d'un risque de décès ou de blessure grave en cas de mauvaise utilisation de l'appareil.
 PRUDENCE	Utilisé pour avertir l'utilisateur d'un risque de blessure ou de dommage matériel en cas de mauvaise utilisation de l'appareil. * Par dommage matériel, il est entendu dommage ou tout autre effet indésirable sur la maison, tous les meubles et même les animaux domestiques.

À propos des symboles

	Le symbole \triangle attire l'attention de l'utilisateur sur les instructions importantes ou les avertissements. Le sens précis du symbole est déterminé par le dessin à l'intérieur du triangle. Le symbole à gauche signifie "danger d'électrocution."
	Le symbole \otimes avertit l'utilisateur de ce qu'il ne doit pas faire, ce qui est interdit. La chose spécifique à ne pas faire est indiquée par le dessin à l'intérieur du cercle. Le symbole à gauche signifie que l'appareil ne doit jamais être démonté.
	Le symbole \bullet prévient l'utilisateur sur ce qu'il doit faire. La chose spécifique à faire est indiquée par le dessin à l'intérieur du cercle. Le symbole à gauche signifie que le fil électrique doit être débranché de la prise.

L'utilisation incorrecte peut causer des blessures

ATTENTION

 **S'assurer de suivre les procédures d'utilisation décrites dans la documentation. Ne jamais permettre à quiconque ne connaît pas le fonctionnement ou la manutention de l'appareil de le toucher.**
L'utilisation ou la manutention incorrectes peuvent causer un accident.

 **Garder les enfants loin de l'appareil.**
L'appareil comporte des zones et des composants qui présentent un danger pour les enfants et qui pourraient causer des blessures, la cécité, la suffocation ou d'autres accidents graves.

 **Ne jamais faire fonctionner l'appareil après avoir consommé de l'alcool ou des médicaments, ou dans un état de fatigue.**
L'utilisation de l'appareil exige un jugement sans faille. L'utilisation avec les facultés affaiblies pourrait entraîner un accident.

 **Ne jamais utiliser l'appareil à des fins autres que celles pour lesquelles il est conçu. Ne jamais l'utiliser de manière abusive ou d'une manière qui dépasse sa capacité.**
Le non-respect de cette consigne peut causer des blessures ou un incendie.

 **Utiliser uniquement des accessoires d'origine (accessoires en option, articles consommables, câble d'alimentation et autres articles semblables), compatibles avec l'appareil.**
Les articles incompatibles risquent de causer des accidents.

 **Débrancher le câble d'alimentation avant de procéder au nettoyage ou à l'entretien de l'appareil, et avant d'y fixer ou d'en retirer des accessoires en option.**
Tenter ces opérations pendant que l'appareil est branché à une source d'alimentation peut causer des blessures ou un choc électrique.

 **Ne jamais tenter de démonter, de réparer ou de modifier l'appareil.**
Le non-respect de cette consigne risque de provoquer un incendie, un choc électrique ou des blessures. Confier les réparations à un technicien ayant la formation requise.

PRUDENCE

 **Faire preuve de prudence pour éviter l'écrasement ou le coincement.**
La main ou les doigts peuvent être écrasés ou coincés s'ils entrent en contact avec certaines surfaces par inadvertance. Faire preuve de prudence pendant l'utilisation de l'appareil.

 **Ne jamais faire fonctionner l'appareil si on porte une cravate, un collier ou des vêtements amples. Bien attacher les cheveux longs.**
Ces vêtements ou ces objets peuvent être coincés dans l'appareil, ce qui causerait des blessures.

 **Utiliser l'appareil dans un endroit propre et bien éclairé.**
Travailler dans un endroit sombre ou encombré peut causer un accident; l'utilisateur risque, par exemple, de trébucher malencontreusement et d'être coincé par une partie de l'appareil.

 **Ne jamais grimper ni s'appuyer sur la machine.**
La machine n'est pas conçue pour supporter le poids d'une personne. Grimper ou s'appuyer sur la machine peut déplacer des éléments et causer un faux pas ou une chute, ce qui causerait des blessures.

 **Attention : outil de coupe.**
Cet appareil contient un outil interne. Pour éviter les blessures, manipuler l'outil avec soin.

⚠ Risque de décharge ou de choc électrique, d'électrocution ou d'incendie

⚠ ATTENTION



Brancher à une prise électrique conforme aux caractéristiques de cet appareil (tension, fréquence et courant).

Une tension incorrecte ou un courant insuffisant peuvent causer un incendie ou un choc électrique.

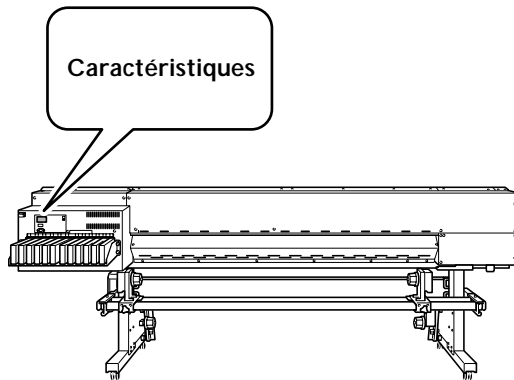

Ne jamais utiliser à l'extérieur ni à un endroit où l'appareil risque d'être exposé à de l'eau ou à une humidité élevée. Ne jamais toucher l'appareil avec des mains mouillées.

Le non-respect de cette consigne risque de provoquer un incendie ou un choc électrique.



Ne jamais insérer d'objet étranger dans l'appareil. Ne jamais exposer l'appareil aux déversements de liquides.

L'insertion d'objets comme des pièces de monnaie ou des allumettes, ou le déversement de liquides dans les orifices de ventilation peuvent causer un incendie ou un choc électrique. Si un objet ou du liquide s'infilte dans l'appareil, débrancher immédiatement le câble d'alimentation et communiquer avec le représentant Roland DG Corp. autorisé.

⚠ ATTENTION



Ne jamais placer d'objet inflammable à proximité de l'appareil. Ne jamais utiliser de produit inflammable en aérosol à proximité de l'appareil. Ne jamais utiliser l'appareil dans un endroit où des gaz peuvent s'accumuler.

Une combustion ou une explosion pourraient se produire.



Manipuler le câble d'alimentation, la fiche et la prise électrique correctement et avec soin.

Ne jamais utiliser un article endommagé, car cela pourrait causer un incendie ou un choc électrique.



Si une rallonge ou une bande d'alimentation électrique sont utilisées, s'assurer qu'elles correspondent aux caractéristiques de l'appareil (tension, fréquence et courant).

L'utilisation de plusieurs charges électriques sur une prise unique ou une longue rallonge peut causer un incendie.



Mise à la terre.

La mise à la terre peut prévenir un incendie ou un choc électrique dus à une fuite de courant en cas de défaillance.



Placer l'appareil de façon à ce que la fiche soit facile d'accès en tout temps.

Ainsi, l'appareil pourra être débranché rapidement en cas d'urgence. Installer l'appareil près d'une prise électrique. En outre, prévoir suffisamment d'espace pour que la prise électrique soit facile d'accès.



S'il se produit des étincelles, de la fumée, une odeur de brûlé, un bruit inhabituel ou un fonctionnement anormal, débrancher immédiatement le câble d'alimentation. Ne jamais utiliser si un composant est endommagé.

Continuer à utiliser l'appareil peut causer un incendie, un choc électrique ou des blessures. Communiquer avec le représentant Roland DG Corp. Autorisé.

⚠ Remarques importantes à propos du câble d'alimentation, de la fiche et de la prise électrique

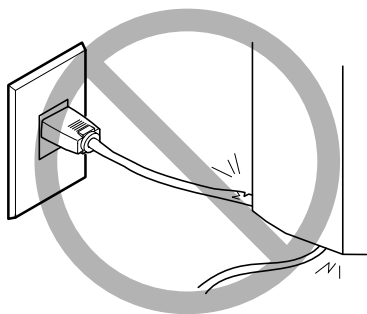

Ne jamais déposer aucun objet sur le câble, sur la fiche ou sur la prise car cela risque de les endommager.

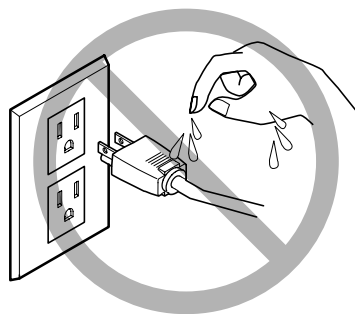

Ne jamais laisser l'eau toucher le câble, la fiche ou la prise.

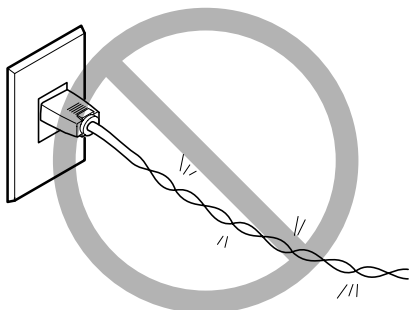

Ne jamais plier ni tordre le câble avec une force excessive.

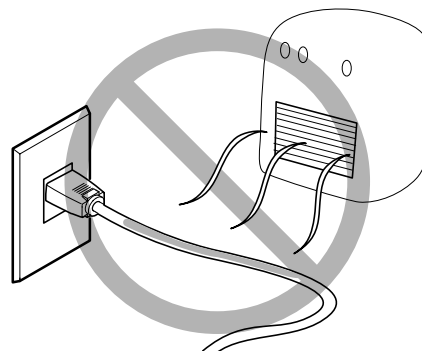

Ne jamais chauffer le câble, la fiche ou la prise.

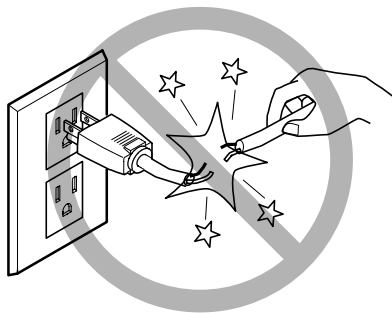

Ne jamais tirer sur le câble ou la fiche avec une force excessive.

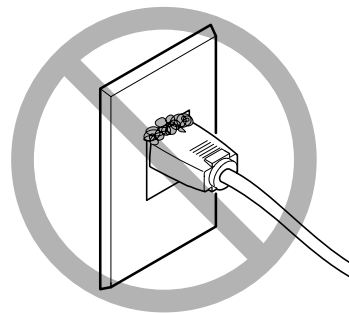

La poussière peut causer un incendie.

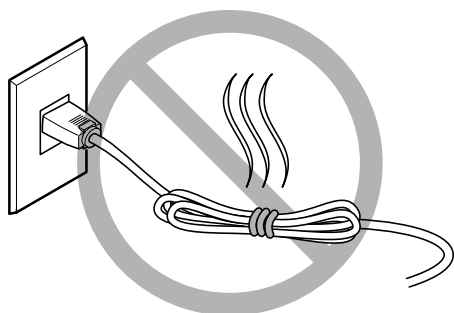

Ne jamais plier ni enrouler le câble.

⚠ L'encre, les liquides nettoyants et les liquides usés sont inflammables et toxiques

⚠ ATTENTION

 **Ne pas approcher une flamme nue de l'espace de travail.**
L'encre et les liquides usés sont inflammables.

 **Ne jamais entreposer d'encre, de liquide de nettoyage ou des liquides usés dans les endroits suivants :**

- un endroit exposé à une flamme nue;
- un endroit où il y a risque de température élevée;
- près d'eau de Javel, d'un autre agent d'oxydation ou de matériel explosif;
- tout endroit à la portée d'enfants.

Il y a risque d'incendie. L'ingestion accidentelle par un enfant peut présenter un risque pour la santé.

 **Ne jamais incinérer une cartouche d'encre.**
De l'encre pourrait couler, s'enflammer et le feu se répandre à des objets proches.

 **Ne jamais boire l'encre, le liquide de nettoyage ni les liquides usés, ne pas en respirer les vapeurs et ne pas laisser les produits entrer en contact avec les yeux ou la peau.**
Cela est dangereux pour la santé.

⚠ PRUDENCE

 **S'assurer que le lieu de travail est bien aéré.**
L'absence d'aération adéquate peut créer une situation dangereuse pour la santé ou un risque de combustion à cause des vapeurs qui émanent de l'encre.

 **Ne jamais soumettre une cartouche d'encre à des chocs. Ne jamais tenter d'ouvrir une cartouche d'encre.**
De l'encre pourrait s'échapper.

⚠ En cas d'ingestion ou de trouble physique

- En cas de contact avec les yeux : rincer immédiatement et abondamment à l'eau courante pendant au moins 15 minutes. Si les yeux sont toujours irrités, consulter un médecin.
- En cas de contact avec la peau : laver immédiatement à l'eau et au savon. En cas d'irritation ou d'inflammation de la peau : consulter un médecin.
- En cas d'ingestion : ne pas provoquer le vomissement et demander immédiatement l'aide d'un médecin. Provoquer le vomissement peut créer un risque de suffocation.
- Si l'odeur cause un trouble physique, amener la personne dans un endroit bien aéré et la faire se reposer. Si l'étourdissement ou la nausée persistent, consulter un médecin.

 **Cet appareil pèse de 250 à 300 kg (550 à 660 lb).
Le support pèse de 30 à 50 kg (66 à 110 lb).**

ATTENTION



Installer l'appareil à un endroit stable et plat et capable de supporter son poids.

Le poids total de l'appareil peut atteindre 300 kg (660 lb) (280 kg (616 lb) pour le XJ-640, 250 kg (550 lb) ou plus pour le XJ-540). Installer l'appareil à un endroit inapproprié peut provoquer un accident grave comme le renversement, la chute ou l'écrasement.



Le déchargement et le positionnement doivent être faits par au moins huit personnes (au moins six personnes pour le XJ-540).

Les tâches qui exigent un effort trop grand si elles sont exécutées par un petit nombre de personnes peuvent être cause de blessures. La chute d'articles très lourds peut aussi causer des blessures.

ATTENTION



S'assurer de verrouiller les roulettes de la base.

Si l'appareil devait commencer à basculer, il s'ensuivrait un accident grave, par exemple l'écrasement de membres ou du corps.



Prendre les mesures de sécurité adéquates pour l'entreposage des rouleaux de support pour s'assurer qu'ils ne rouleront pas, ne tomberont pas et ne se renverseront pas.

Il y a risque d'être écrasé par le support et de subir des blessures graves.



La manutention du support en rouleau doit être faite par deux personnes ou plus et il faut prendre des précautions pour éviter les chutes.

Tenter de soulever des objets trop lourds peut causer des blessures.

 **Risque d'incendie, de brûlures ou d'émissions de gaz toxiques**

ATTENTION



Attention : températures élevées.

Les zones comme le séchoir chauffent. Faire preuve de prudence pour éviter un incendie ou des brûlures.



Quand aucun travail d'impression n'est en cours, retirer tout support de l'appareil ou couper l'alimentation électrique.

L'application continue de chaleur à un point unique peut causer l'émission de gaz toxiques ou créer un risque d'incendie.

ATTENTION



Ne jamais utiliser un support qui ne peut pas supporter la chaleur.

L'utilisation d'un support qui ne supporte pas la chaleur peut détériorer le support, créer un risque d'incendie ou causer l'émission de gaz toxiques.

⚠ Vignettes d'avertissement

Des vignettes d'avertissement sont apposées pour qu'il soit facile de repérer les zones dangereuses. La signification des vignettes est donnée ci-dessous. Respecter les avertissements. Ne jamais retirer les vignettes et ne pas les laisser s'encrasser.

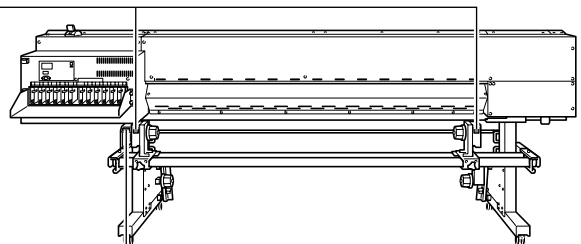
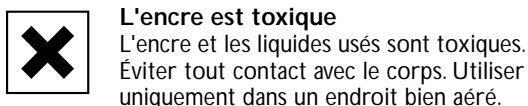
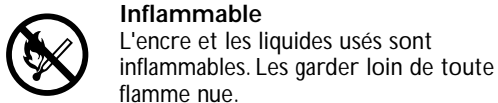
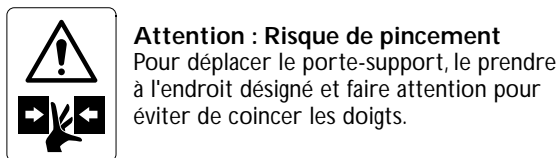
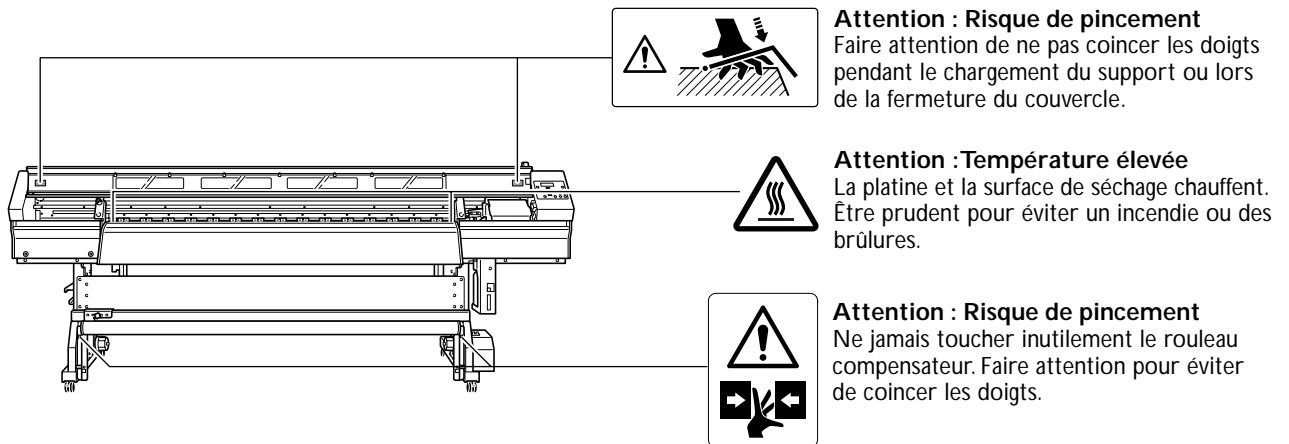
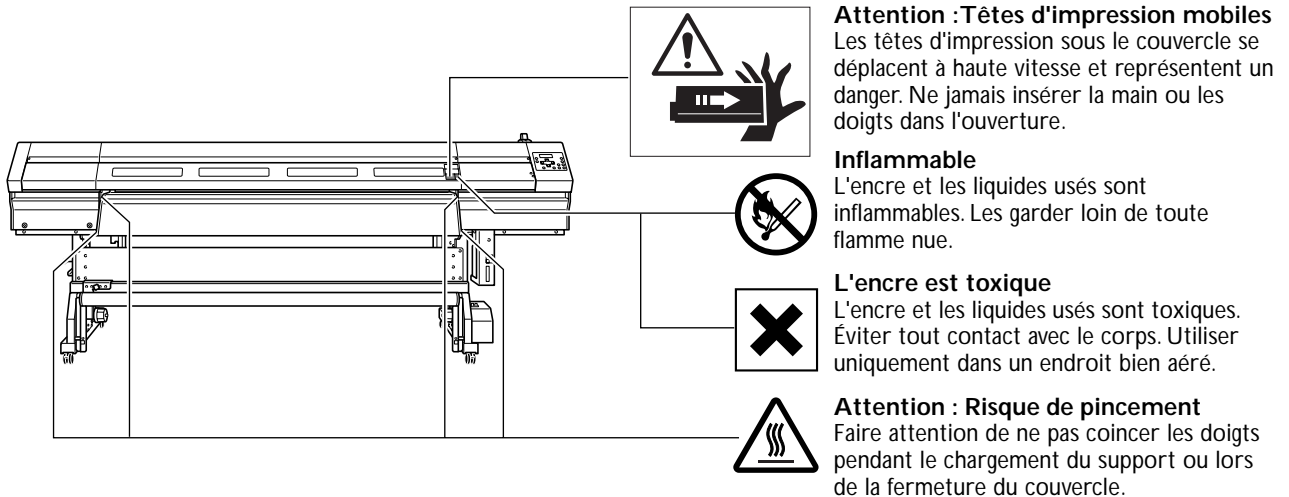

Important Notes on Handling and Use

This machine is a precision device. To ensure the full performance of this machine, be sure to observe the following important points. Failure to observe these may not only result in loss of performance, but may also cause malfunction or breakdown.

Printer unit

This Machine Is a Precision Device

- Handle carefully, and never subject the machine to impact or excessive force.
- Never needlessly put your hand or fingers inside the cover, the ink-cartridge ports, or other internal areas of the machine.

Install in a Suitable Location

- Install in a location having the specified temperature and relative humidity.
- Install in a quiet, stable location offering good operating conditions.

The Print Heads Are Delicate

- Never needlessly touch or allow media to scrape them. Failure to handle with care may cause damage.
- The print heads may be damaged if allowed to dry out. The machine prevents desiccation automatically, but improper operation may render this feature inoperative. Operate properly, as specified in this manual.
- Never allow the machine to stand with an ink cartridge removed. Remaining ink in the printer may harden and clog the print heads.
- The print heads are components that wear out. Periodic replacement is required, with the frequency of replacement depending on use.

This Machine Becomes Hot

- Never cover the ventilation holes with cloth, tape, or anything else.

Ink cartridges

Ink Cartridges Come in Various Types

- Use a type that is compatible with the printer. Also, be sure to use only genuine items from Roland DG Corp.

Never Subject to Impact or Attempt to Disassemble

- Never drop or shake forcefully. The impact may rupture the internal pouch and cause the ink to leak.
- Never attempt to disassemble.
- Never attempt to refill the ink.
- If ink gets on your hands or clothing, wash it off as soon as possible. Removal may become difficult if allowed to stand.

Storage

- Store unopened in a well-ventilated location at a temperature of -20 to 40°C (-4 to 104°F).

Chapter 1

Introduction

1-1 Features of the Machine

What Is the XJ-740/640/540?

The XJ-740/640/540 is a large-format printer capable of high-speed, high-quality printing, and is equipped with the features described below.

Built-in Print Server

This machine has a built-in print server as a network interface. When you use the print server, you can send printing data to the machine from anywhere on the network.

Built-in Drying Systems

This machine has a built-in print heater and preheater to improve ink adhesion and speed up drying. It also has a drying heater to speed up drying of the media after printing. This enhances productivity by enabling support for more types of media.

Includes a Media Take-up System

To accommodate printing of lengthy media, the machine includes a media take-up system. This is capable of taking up media automatically during printing. This makes possible unattended operation at night and efficient printing of lengthy media.

Includes a Software Raster Image Processor (RIP)

The software RIP included with the machine lets you use your computer to perform raster image processing for printing data such as PostScript files exported from a program, and output the data to the machine.

1-2 Part Names and Functions

Printer Unit

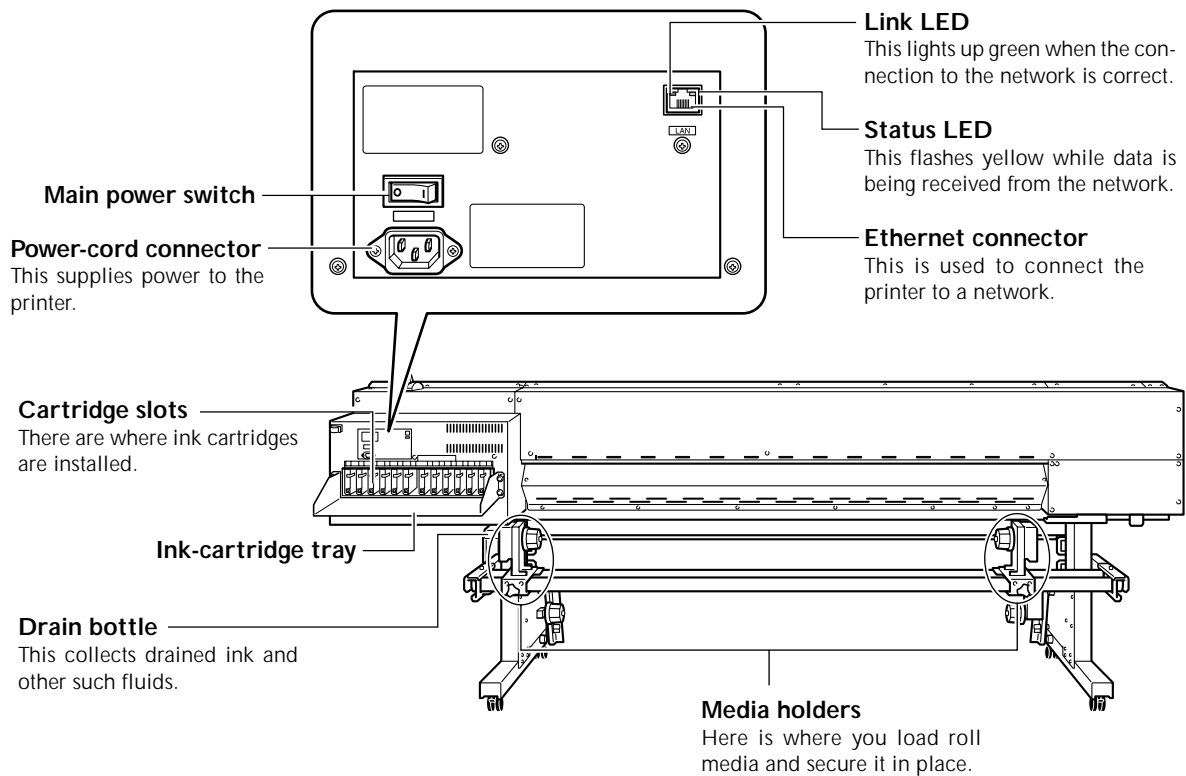
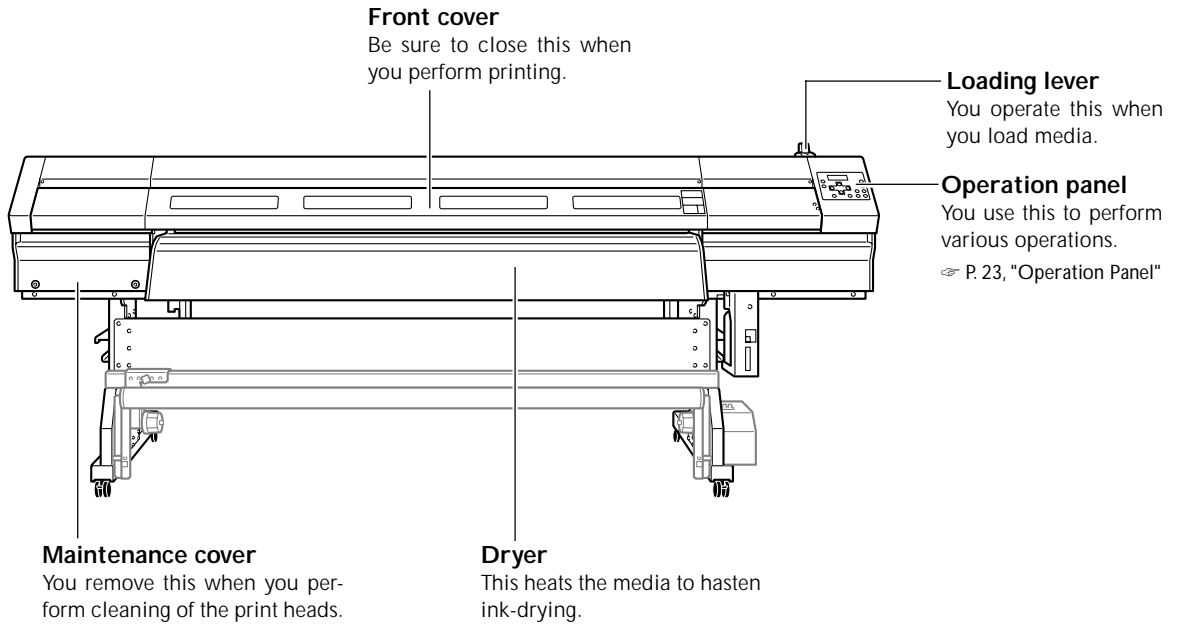

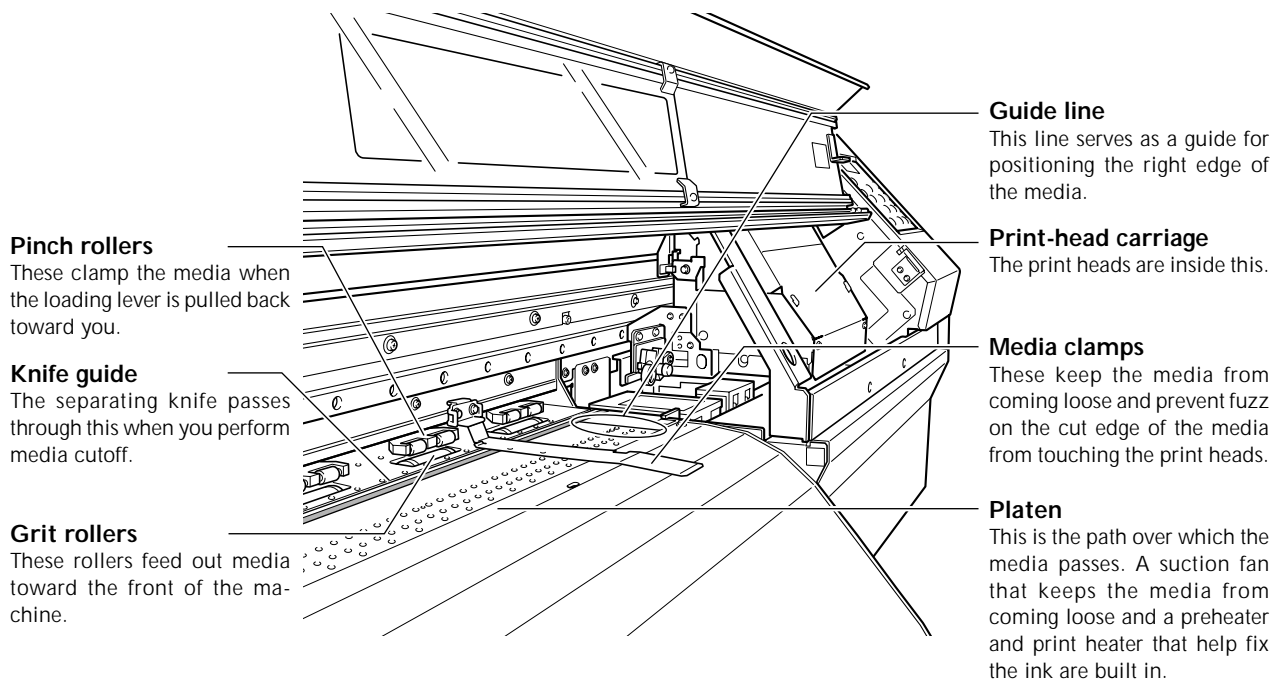

Operation Panel

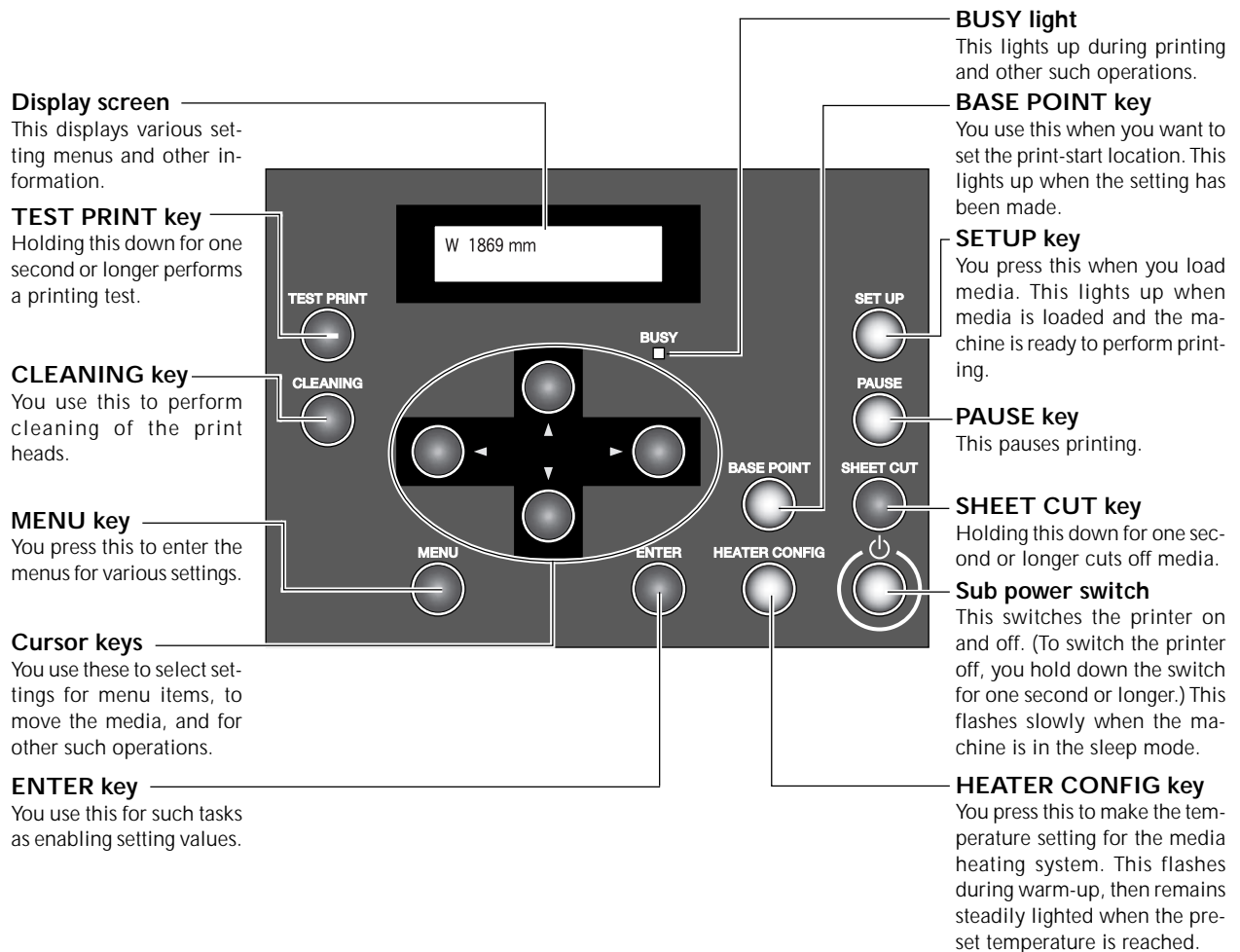

Panel Notation

In this document, the keys on the operation panel are indicated by the following images.

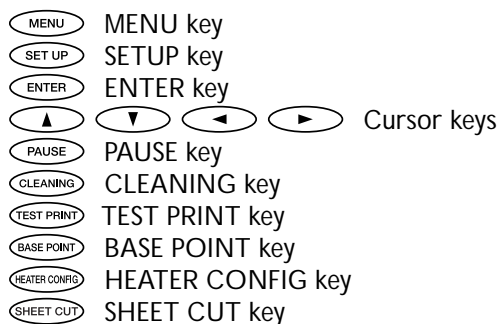

Media Take-up System

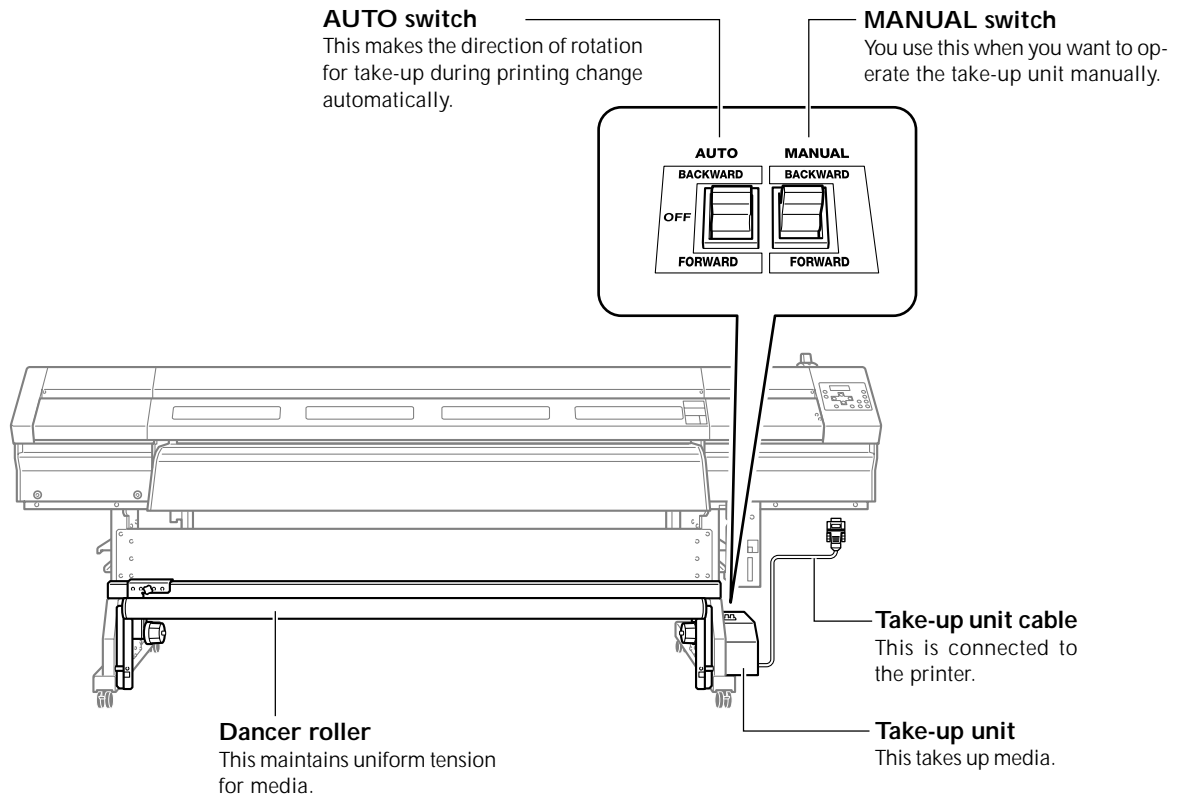

Chapter 2

Basic Operation

2-1 Switching the Power On and Off

Switching the Power On and Off

This machine has a main power switch and a sub power switch. Switch on both to use the machine. Whenever printing is finished, switch off the sub power. You also flip down the loading lever to the rear of the machine.

Leave the main power switch ① on at all times, never switching it off. Leaving it on activates the alarm feature.

☞ P. 64, "Alarm Feature"

⚠ WARNING When printing is not being performed, remove any loaded media or switch off the sub power.

The continued application of heat at a single location may cause the release of toxic gases from the media or pose a fire hazard.

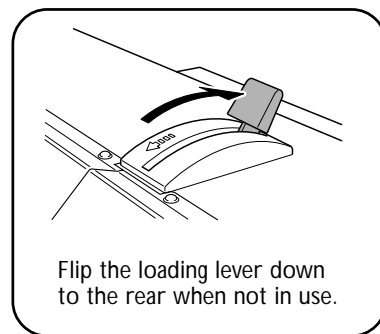
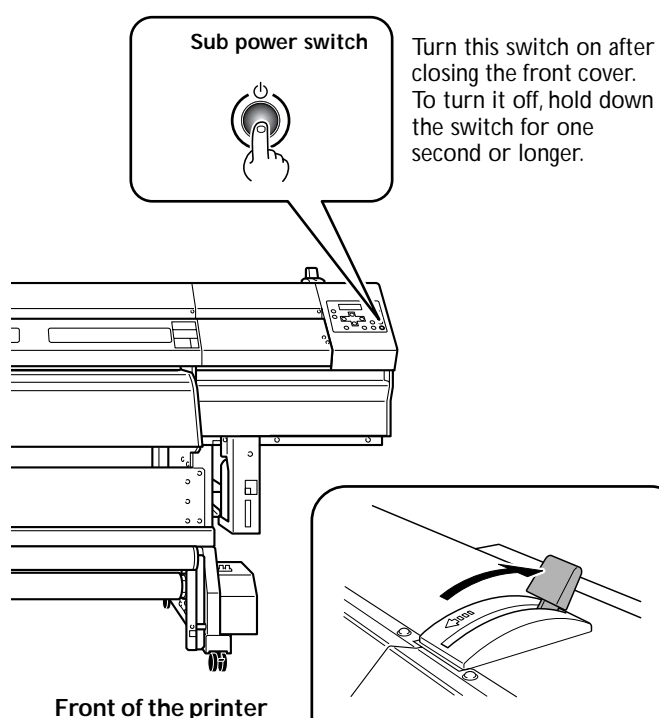
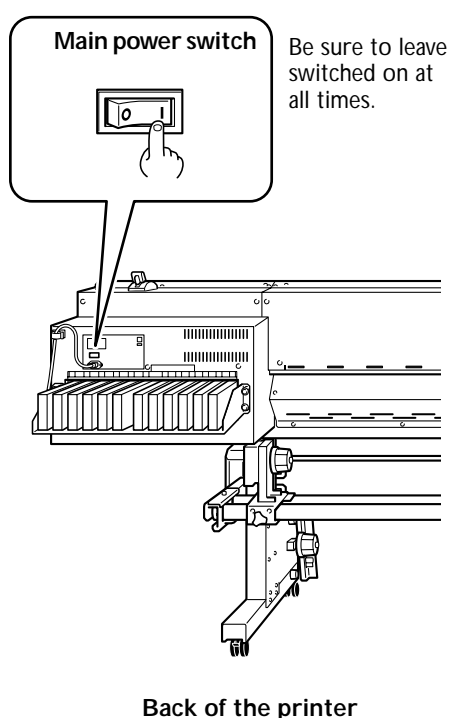

Important Note on Switching Off the Power

Never switch off the main power or unplug the power cord suddenly while operation is in progress. Doing so may damage the print heads. Be sure to first switch off the sub power. If the main power is accidentally switched off, immediately turn the power back on.

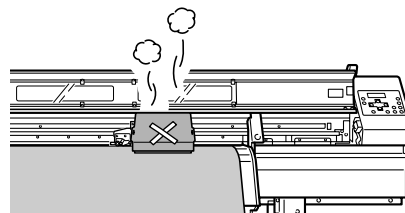

The Power-saving Feature

This machine is provided with a power-saving feature that switches to a low-power "sleep mode" when a fixed interval passes with no operation. The factory default for the time after which the machine switches to the sleep mode is 30 minutes.

You can change the setting for the time of the shift to the sleep mode. You can also switch off the power-saving feature.

☞ P. 78, "Setting the Interval until Activation of the Sleep Mode," p. 78, "Deactivating the Sleep Mode"

When the machine is in the sleep mode, the sub power switch flashes slowly. Using the operation panel or performing operations such as sending printing data from the computer (when media is loaded) restores the machine to its normal mode.

To reduce power consumption and prevent problems such as overheating, we recommend leaving the power-saving feature on and setting the activation time for the sleep mode to 30 minutes or less.

2-2 Loading and Cutting Off Media

Usable Media

For information about media that can be used with this machine, refer to the page indicated below.

☞ P.118, "Conditions for Usable Media"

Loading Media

Media may be of one of two types: media wound onto a paper tube (called "roll media") and media not rolled in this way (called "sheet media"). This section explains how to load media, using roll media as an example. For information on how to load sheet media, refer to the page indicated below.

☞ P.76, "How to Load Sheet Media"

- ⚠ CAUTION** **Load roll media correctly.**
Otherwise the media may fall and cause injury.
- ⚠ CAUTION** **Roll media weighs about 30 kg (66 lb.) to 50 kg (110 lb.). Handling roll media is an operation that must be performed by two persons or more, and care must be taken to prevent falls.**
Attempting to lift heavy media in a manner that taxes your strength may cause physical injury. Also, if dropped, such items may cause injury.
- ⚠ CAUTION** **Never load media that exceeds the loadable weight.**
The machine may fail to withstand the weight and tip over or cause the media to fall.

1. Load roll media and align the left and right sides.

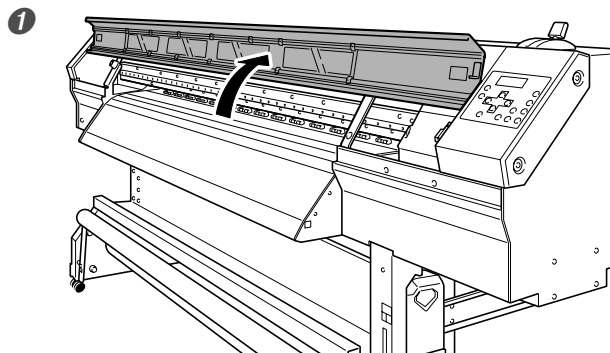

Open the front cover.

2 Go around to behind the printer and move the media holders all the way to the left and right.

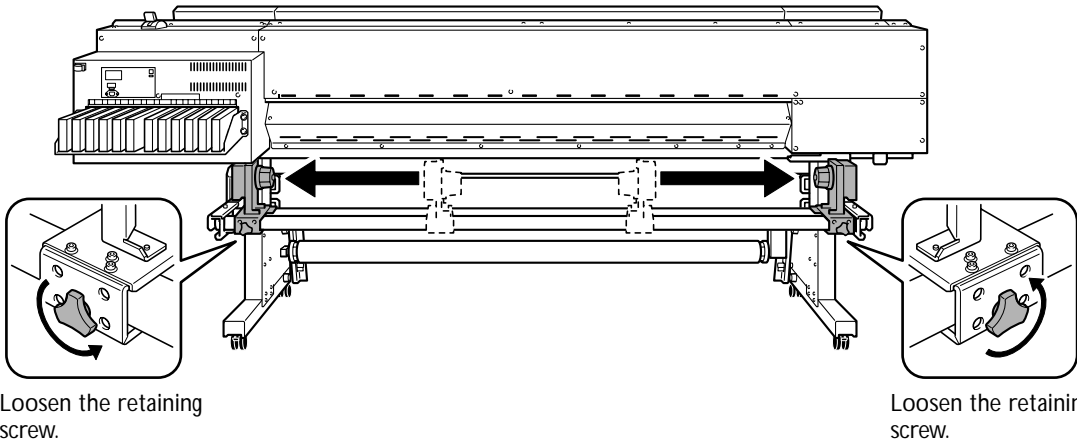

3 If the diameter of the media core is two inches, detach the end caps from the media holders and replace them with the included media flanges.

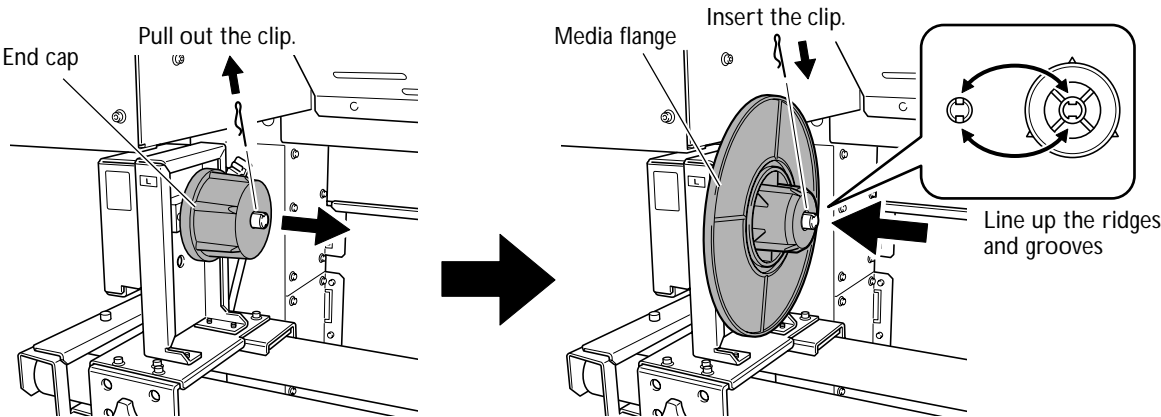

4 Attach the media to the media holders.

Attach the media to the left media holder.

Move the right media holder to the left and attach the media.

Load the media while the left media holder is positioned close to the left edge, as shown in the figure. Also, never secure the media holder in place before loading the media. Loading media without performing these steps in the proper order may make smooth media feed impossible or yield poor printing results.

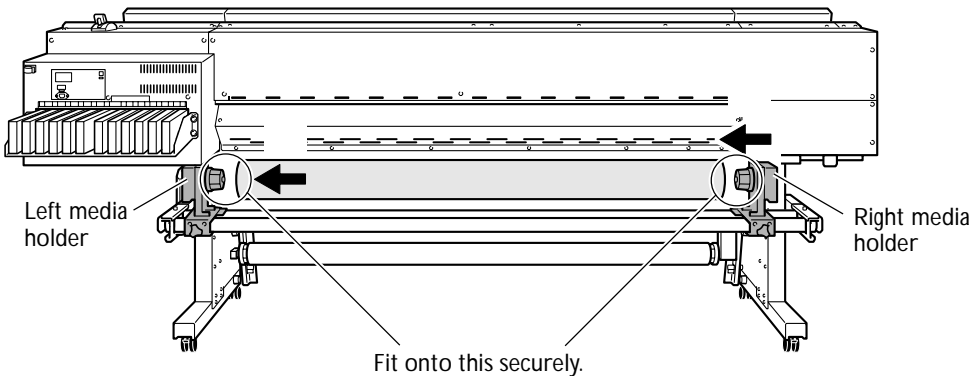

- 5 Grasp the location shown in the figure and align the left edge of the media with the mark.
If the media is moved too far to the right, grasp the right media holder at its outer side and shift it to the left.

CAUTION Never attempt this operation while holding any location other than the one specified.
The media may fall from the media holder, resulting in injury.

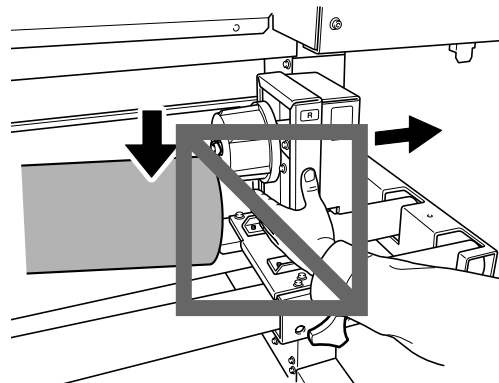
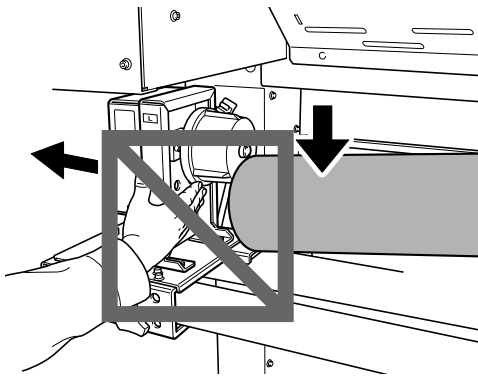
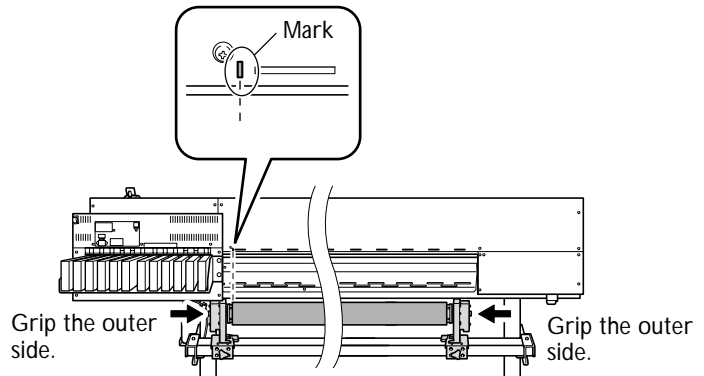
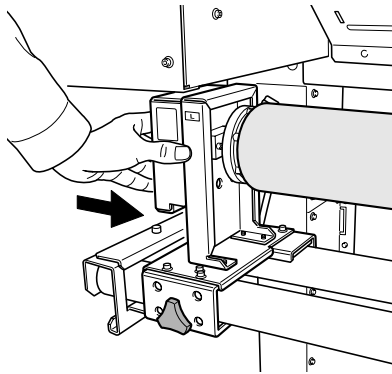

Never attempt to move while holding the inner side of the media holder.
The media may fall and cause injury.

- 6 Secure the media holders in place.
Tighten the retaining screws securely.

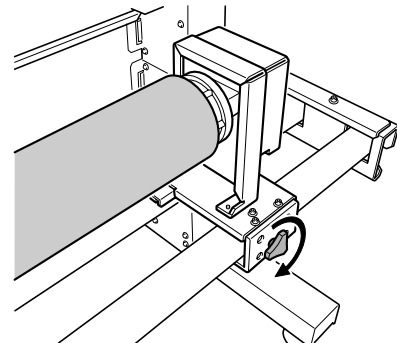
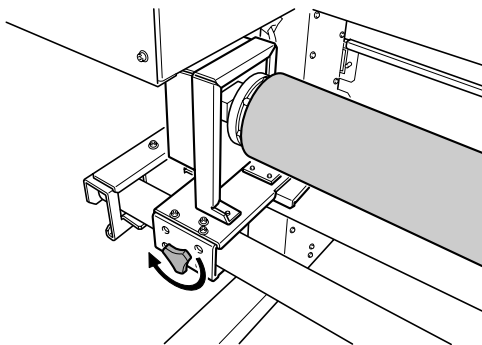

2. Pass the media through the printer and secure it in place so that no slack occurs.

- 1 Pull out the media, pass its leading edge through between the pinch rollers and the grit rollers, and feed it through as far as the platen.
Make sure the left edge of the media lies along the guide line.

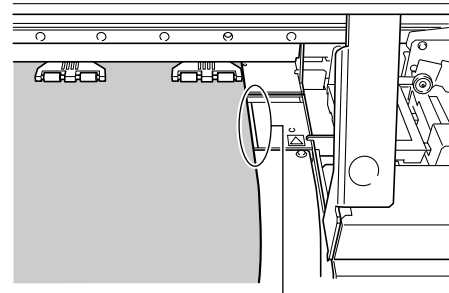
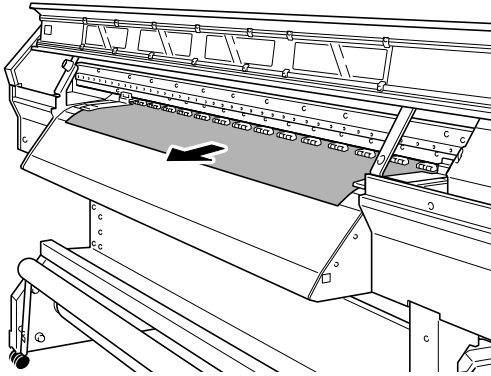

Guide line

- 2 Hold the media at the center and pull it out, being sure to keep it straight.
Make sure all areas of the media are taut.

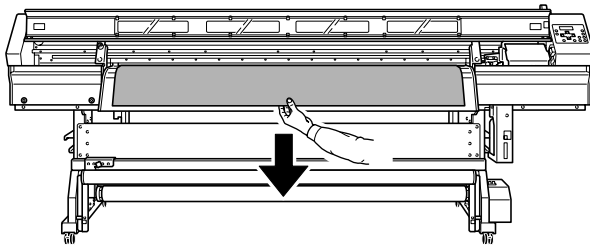

OK

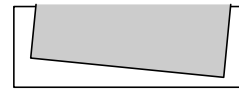

Not OK

3

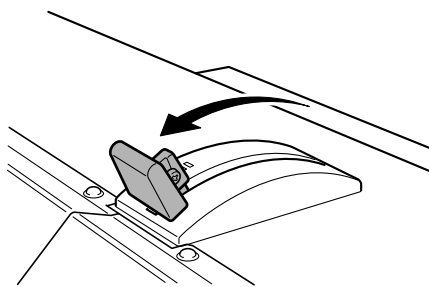

Pull back the loading lever.
The media is secured in place.

3. Attach the media clamps and close the front cover.

1 Attach the media clamps.

The media clamps are magnetic, and the left and right clamps are distinct. Refer to the figure and install them at the correct positions, taking care not to let the left and right clamps get mixed up.

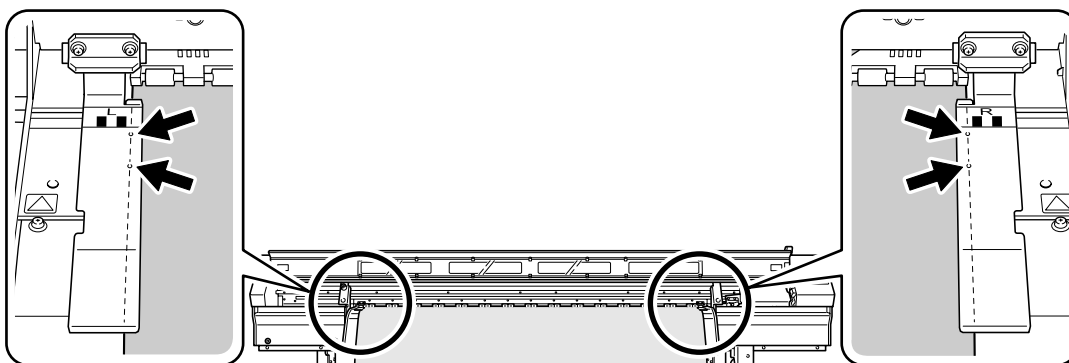

Left media clamp
Align the edge of the media with the centers of the holes.

Right media clamp
Align the edge of the media with the centers of the holes.

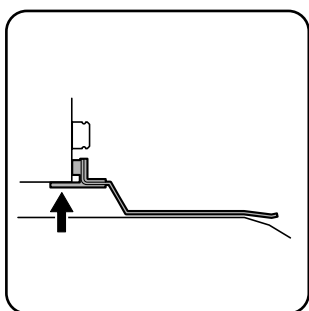

How to install correctly

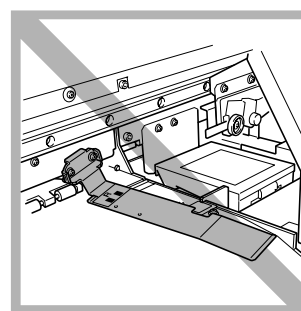
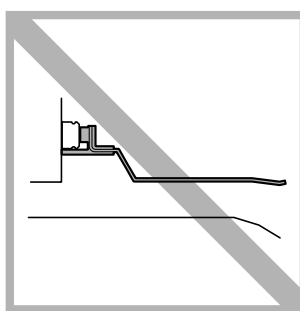

2

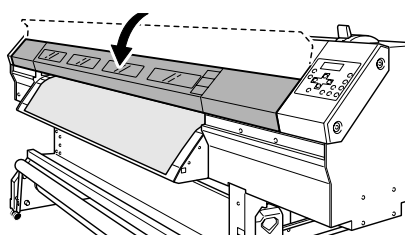

Close the front cover.

3



Use to select "ROLL."

4

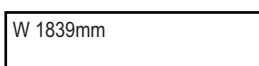

Press .
 starts to flash. When initialization ends, remains steadily lighted, and the printable width is displayed.

Remove when not using roll media.

If roll media is allowed to stand unused in a loaded state for an extended period, the media may sag. This can cause poor printing quality and motor errors, so be sure to remove and store such media when not in use.

How to Cut Off Media

To cut off the media, use **SHEET CUT**. You can carry this out only when **SET UP** is illuminated and the top menu screen is displayed.

Procedure

1

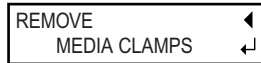

Make sure **SET UP** is lighted, and press and hold **SHEET CUT** for one second or longer.

The screen shown in the figure appears.

2

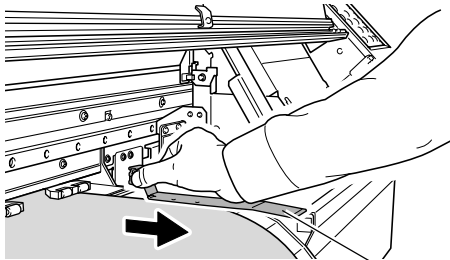

Media clamp
Remove the one on
the left as well.

Open the front cover and detach the left and right media clamps.

3

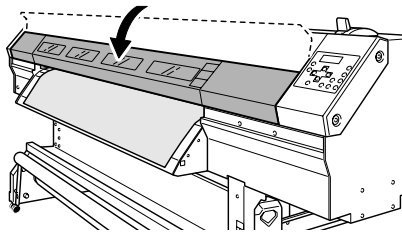

Close the front cover.

4

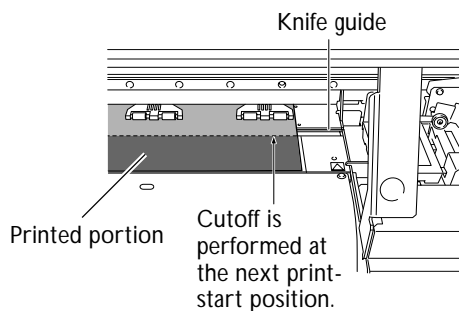

Press **ENTER**.

The media is cut off.

You can make the setting in the software RIP for automatic media cutoff after printing has finished. For information on how to make the setting, refer to the documentation for the software RIP you're using.

Cut-off Operations

- Be sure to detach the media clamps. Performing cutoff with the media clamps remaining attached may cause the operation to be interrupted due to detection of the media clamps.
- If the media clamps are present on the machine when the setting to execute automatic cutoff of the media is made on the computer, the media clamps are detected and no cutoff operation is performed.
- When you're performing cutoff, never use **▲** to pull the media back. Unless the end of the media has been pulled out to a location to the front of the platen, cutoff may not be performed smoothly.

2-3 Settings for the Media Heating System

What Is the Media Heating System?

This machine is equipped with a media heating system that warms the media. You use this mainly to improve ink adhesion and dry the ink. You can adjust the temperature settings to match the type of media and the printing speed.

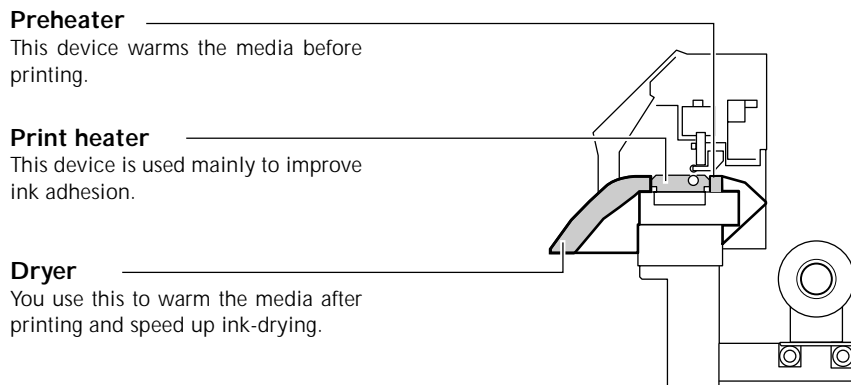

- ⚠ WARNING** **Caution: high temperatures**
The platen and dryer become hot. Exercise caution to avoid fire or burns.
- ⚠ WARNING** **Remove any loaded media or switch off the sub power when printing is not being performed.**
The continued application of heat at a single location may cause fire or produce toxic gases.
- ⚠ WARNING** **Never use media that cannot withstand the heat.**
Doing so may result in fire or the release of toxic gases, or may degrade the media.
- ⚠ WARNING** **Never use the platen or dryer for any purpose for which they are not intended, such as to dry clothing.**
Doing so may cause overheating, resulting in fire or accident.

Making the Temperature Setting for the Media Heating System

Procedure

- 1**

PRE	35	PRINT	35
DRY	50		

 Press **HEATER CONFIG**.
The present temperature is displayed.
- 2**

DRYER	50	◀▶
	50	▶ 50◀

 Press **HEATER CONFIG** a second time.
Use **◀** **▶** to select the device.
- 3**

DRYER	50	◀▶
	55	▶ 55◀

 Use **▲** **▼** to make the setting.
Press **ENTER** to enable the setting.
- 4**

W 1839mm
SETUP SHEET
◀▶ ROLL

 Press **MENU**.
Press **◀** to go back to the original screen.

By default, simply switching on the power does not make the machine warm up to the preset temperature. Pressing **SET UP** to make the light come on makes the system warm up to the preset temperature.

General Guide for the Preset Temperatures

The optimal temperature for the media heating system varies according to such factors as the type of media and differences in the print mode. Use the following as a general guide and adjust accordingly.

General Guide for Adjustment

Preheater

Set this to a temperature that is the same as or lower than the temperature of the print heater.

You use the preheater mainly to heat media gradually. This is because media becomes more likely to shrink or wrinkle if heated suddenly.

Print heater

You use this mainly to improve ink adhesion and inhibit smudging.

If the ink forms lumps or smudges, raise the temperature. Note, however, that a temperature that is too high may degrade the media or cause it to wrinkle.

Dryer

When ink drying is poor, raise the temperature. Note, however, that a temperature that is too high may degrade the media or cause it to wrinkle.

The relationship between the print mode and temperature

If smudging or poor drying occurs even after raising the temperature, try using a print mode offering higher image quality. Conversely, when you want to use a faster print mode, raise the temperature.

Amount of ink

When you change the amount of ink using the settings for your software RIP, adjusting this may yield better results. If problems such as smudging persist even after raising the temperature, try reducing the amount of ink.

Use at an ambient temperature of 20 to 32°C (68 to 90°F).

If the machine is used at an ambient temperature lower than 20°C (68°F), then depending on the type or width of the media, wrinkling or temperature-caused unevenness may occur. To obtain stable printing results, the machine should be used at an ambient temperature of 20 to 32°C (68 to 90°F).

Examples of Preset Temperatures

Media	Temperature
Type: Scrim banner (PVC) Thickness: 300 to 400 µm (12 to 16 mil)	Preheater: 40°C (104°F) Print heater: 40°C (104°F) Dryer: 50°C (122°F)
Type: Marking film (PVC, with adhesive) Thickness: 60 to 100 µm (2.5 to 4 mil, not including backing paper)	Preheater: 35°C (90°F) Print heater: 35°C (90°F) Dryer: 50°C (122°F)

- These are only rough estimates. Make adjustments to match the media you're using.
- Using the media heating system does not necessarily make it possible to apply ink to every kind of media. Be sure to test in advance.
- Results may vary greatly depending on the print mode and other factors. Make settings suited to the media.
- When suggested settings for temperature, print mode, and other values are given, use the suggested settings.

2-4 Starting Printing

Getting Ready to Receive Data from a Computer

When you have finished loading media and making the temperature settings for the media heating system, then follow the steps below. This procedure enables the machine to receive data from the computer and perform printing.

Procedure

- 1 Close the front cover.
- 2 Make sure **SET UP** lights up.
- 3 Wait until **HEATER CONFIG** stops flashing and stays steadily lit.
- 4 Make sure you are at the top menu.
If you are not at the top menu, press **MENU**, then press **◀**.

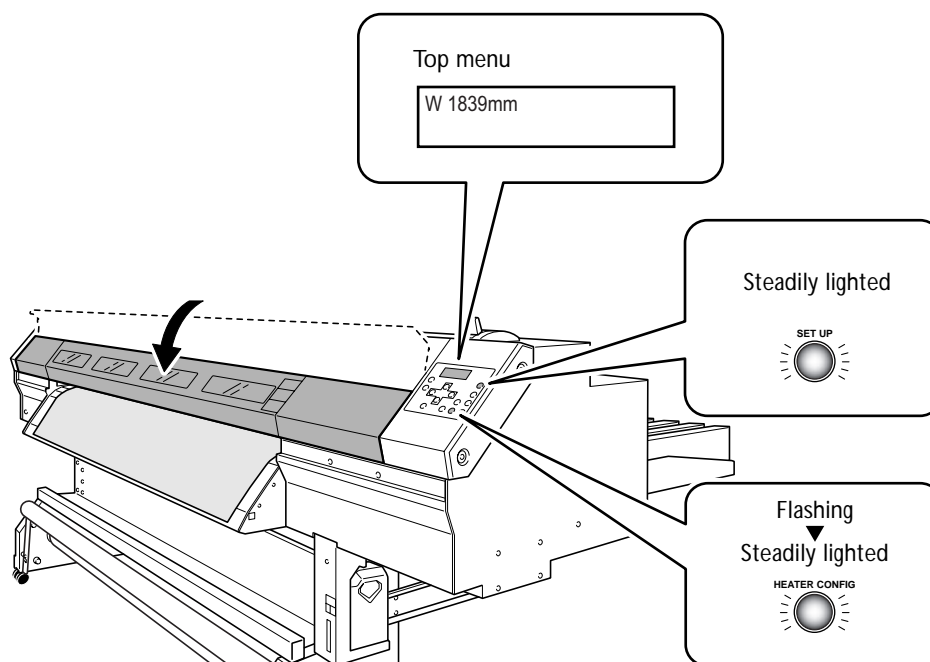

Printing Is Not Possible in These Situations

- > The machine does not run when the front cover is open. Also, never open it when printing is in progress. Doing so interrupts printing.
- > Data from the computer is not accepted when **SET UP** is dark.
- > Printing does not start until **HEATER CONFIG** lights up.
- > Data from the computer is not accepted when you are not at the top menu.

Points Which Must Be Observed

- > Be sure to set the media clamps during printing. Otherwise the edges of the media may warp and catch on the print heads.
- > During printing, never touch the media that's already been discharged. Doing so may obstruct media feed or cause the media to rub against the heads, which may result in a paper jam or damage to the heads.

Printing Tests and Cleaning

We recommend performing a printing test to check for problems such as dot drop-out before you carry out actual printing. If problems such as dot drop-out are found, clean the print heads.

How to Perform a Printing Test

Hold down for one second or longer.

TEST PRINT

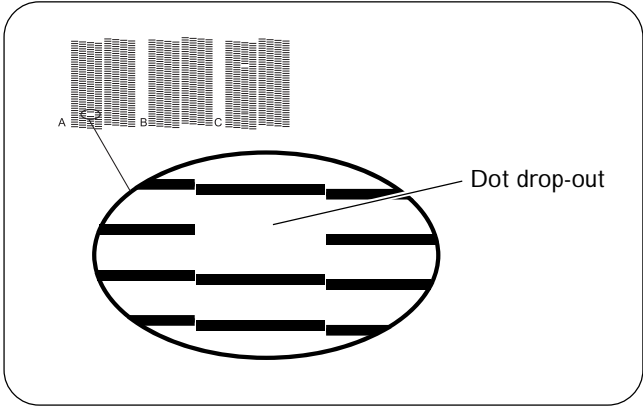

Test pattern

BASE POINT

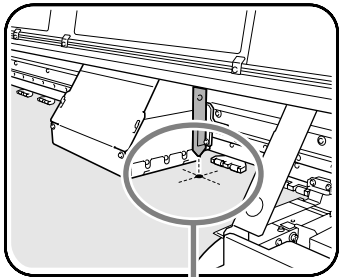

Holding down **TEST PRINT** for one second or longer prints a test pattern.

You can print the test pattern where you want by using **◀** **▶** **▼** to move the print-head carriage, then pressing **BASE POINT**. The front cover may be left open during movement, but be sure to close it before you press **TEST PRINT**.

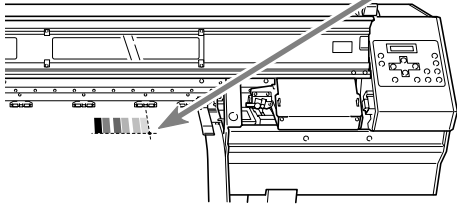

How to Perform Cleaning

When a printing test reveals dot drop-out or the like, perform cleaning for just the group of heads that is incapable of correct printing. Compared with performing cleaning for all heads, this can reduce the amount of ink consumed.

Procedure

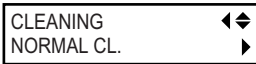
1 

Press **CLEANING**.

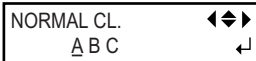
2 

Press **▶**.

3 

Use **◀** **▶** to choose the group of heads that is not to be cleaned.
Use **▲** **▼** to get rid of the group display.

Repeat this procedure to display the groups of only the heads that require cleaning.

Of groups A through C, cleaning is performed only for the groups displayed.

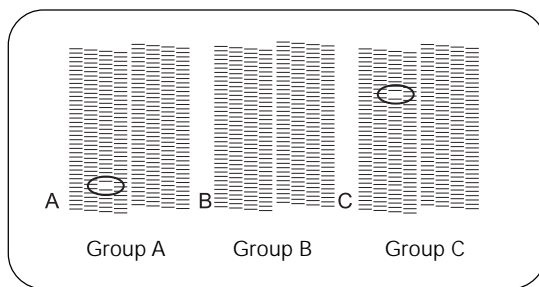

Printing-test results

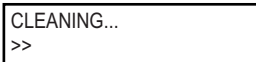
4 

Press **ENTER**.
Cleaning starts.

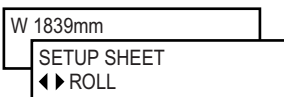

When it finishes, the screen shown in the figure appears again.

5 

Press **MENU**.
Press **◀** to go back to the original screen.

6 Perform a printing test again to make sure the dot drop-out has been corrected.

If the problem persists, try performing cleaning a second time.

If the problem doesn't go away even after performing cleaning two or three times, then try cleaning using a different method.

☞ P.54, "When Head Cleaning Is Not Effective"









When you want to clean all heads simultaneously

Hold down **CLEANING** for one second or longer. Cleaning for all heads starts automatically.

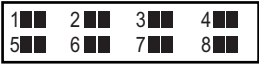
2-5 If Ink Runs Out

Checking for Remaining Ink

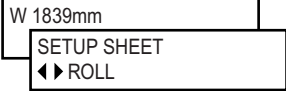
Procedure

-  Press .
Press  several times.
-  Press .
-  Press .
-  Press .
Press  to go back to the original screen.

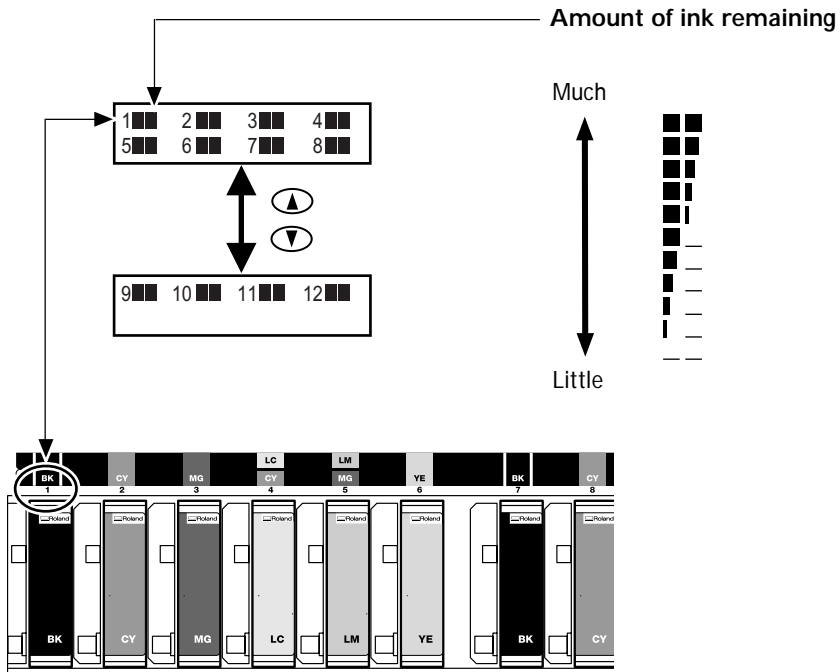

The display shows an approximate guide to the amount of remaining ink, which may differ somewhat from the actual amount remaining.

When Ink Cartridges Become Empty

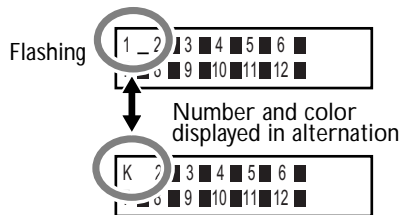

When ink runs out, a warning beep sounds and printing pauses. Then a screen like the one shown in the figure appears (unless the default settings have been changed). Pull out the empty cartridge and insert a new one. Printing resumes.

Procedure

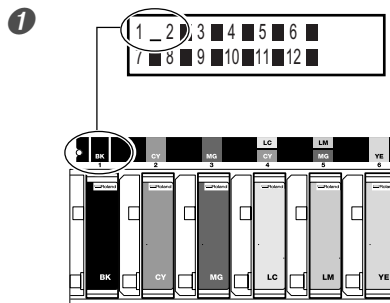

Check which cartridge is empty.

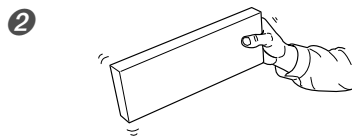

Gently shake the new cartridge.

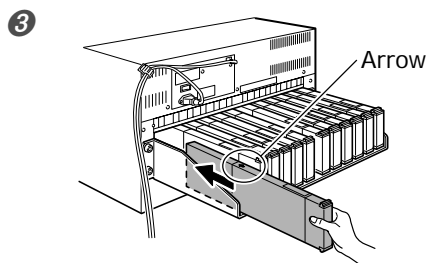

Pull out the empty cartridge and immediately insert the new one.

- Orient so that the surface with the arrow is facing up.
- Insert and remove slowly, one at a time.
- Insert firmly, as far as it will go.

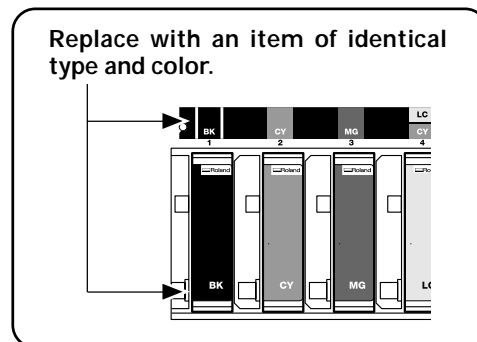

Important Notes on Replacing Cartridges

- Be sure to replace with an item of identical type. Never mix items of different types.
- Never allow the machine to stand with an ink cartridge removed. The print heads may become clogged.
- Never insert or remove a partially used ink cartridge.
- Never remove an ink cartridge suddenly while the printer is in operation.
- When printing is paused, the coloring at the seam may be altered when printing resumes. Before you perform lengthy printing, check the amount of ink remaining in the ink cartridges.

- ⚠️ WARNING** Never store ink, cleaning fluid, or discharged fluid in any of the following locations.
- Any location exposed to open flame
 - Any location where high temperature may occur
 - Near bleach or any other such oxidizing agent or explosive material
 - Any location within the reach of children
- Fire may be a danger. Accidental ingestion by children may pose a health hazard.

Chapter 3
Operation of the Media
Take-up System

3-1 The Take-up System

Features of the Take-up System

Using the take-up system lets you perform printing while the media is taken up automatically. This makes possible unattended operation at night and efficient printing of lengthy media.

Operating Conditions for the Take-up System

Settings Related to Media Feed

When using the take-up system, to avoid pulling media with undue force, be sure to observe the following points. Operations that pull the media with undue force, such as unsuitable take-up by the take-up system, can cause printing to stop or result in misalignment of the printing position.

- Never use  to pull the media back.
 - Never operate the MANUAL switch for the take-up unit when the loading lever is pulled back.
 - When loading and setting up media, set the [SETUP SHEET] menu item to "TU."
 - Set the [FEED FOR DRY] menu item to "DISABLE."
- ☞ P. 88, "Drying the Trailing Edge of the Printing Area on the Dryer"

When Performing Continuous Printing of Two or More Pages

When you're performing continuous printing and take-up for two or more pages, give attention to the following points.

- If the setting to execute automatic cutoff of the media can be made on the computer, then turn this setting off. Making the setting on the computer to execute automatic cutoff of the media results in media cutoff after each page is printed. (If the media clamps are installed, the clamps are detected and the cutoff operation is not performed.) Take-up quits as soon as the media is cut off.
- On the computer, set the margin from the print-end position to the next print-start position (the page spacing) to 40 millimeters or more. Setting this to a value of less than 40 millimeters may cause the media to be pulled with undue force and result in printing being interrupted.

3-2 Using the Take-up System

Loading Roll Media

1. Pass the media through the printer.

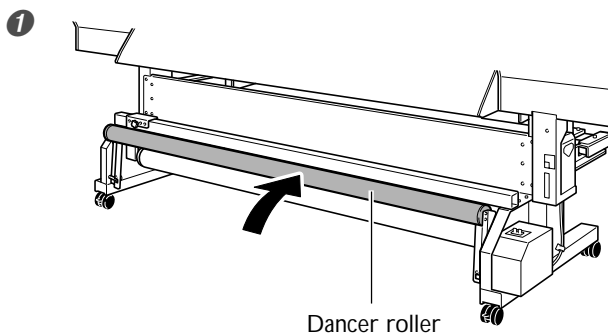

Move the dancer roller toward the rear.

2 Load the roll media.
☞ P. 28, "Loading Media "

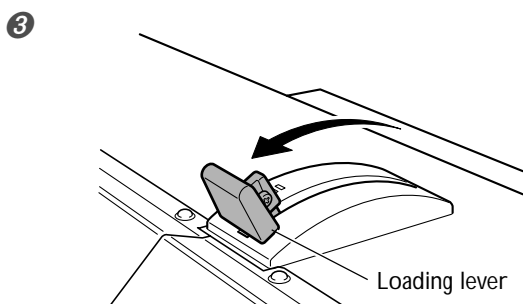

Pull back the loading lever.
The media is secured in place.

2. Fasten the media to the paper tube.

When you attach the paper tube, insert it securely onto the end caps on the take-up unit. For information on how to install it, refer to the Setup Guide.



Use ◀ ▶ to select "TU."

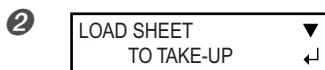

Press **SET UP** .
The screen shown in the figure appears.

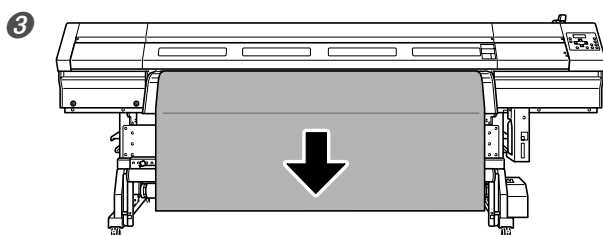

Press ▼ to adjust the length of the media to be pulled out.
You can adjust the length of the media in 10-millimeter steps by pressing ▼ .
(To pull out media continuously, hold down ▼ .)

- 4 Fasten the media in place with tape at three locations (the center and both edges) so that the media is not at an angle.

Take-up with outward curl

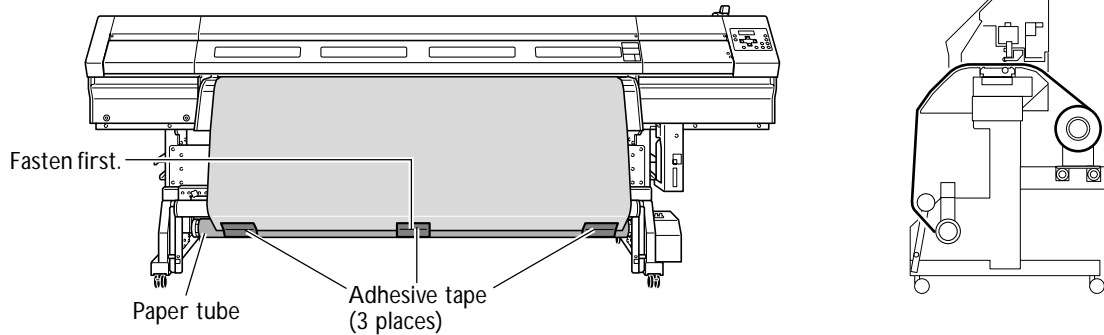

Take-up with inward curl

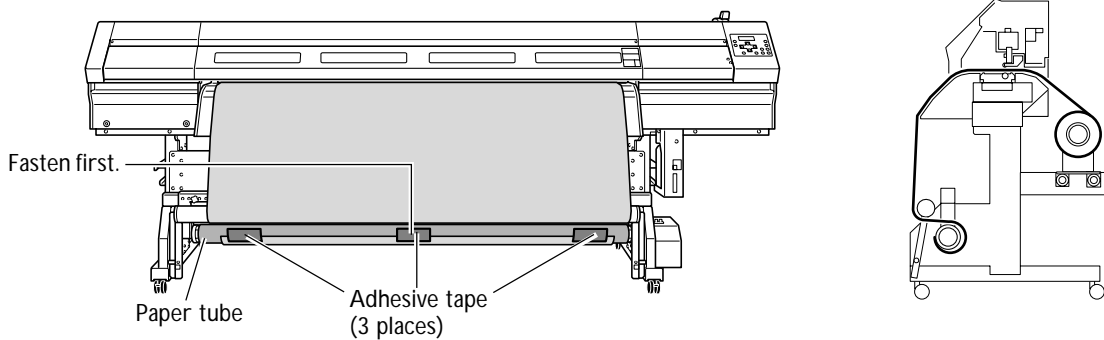

3. Make the setting for the direction of automatic take-up and perform take-up of the media onto the paper tube.



Press **ENTER**.

The media is pulled out and the screen shown in the figure appears.

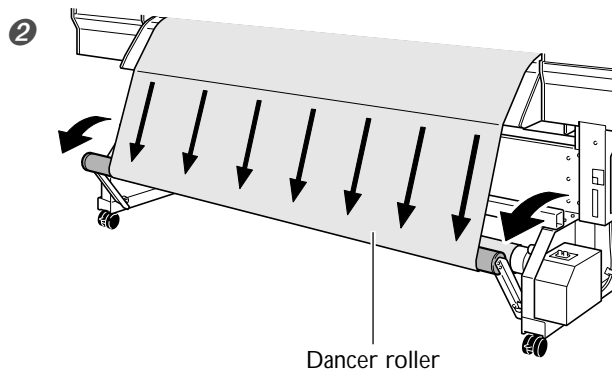

Pull the dancer roller back toward you.

3 CHECK TAKE-UP SETTING ↵

Make sure the media is stretched taut, and press **ENTER**.
The screen shown in the figure appears.

4 Make the setting for the AUTO switch on the take-up unit.

Take-up with outward curl

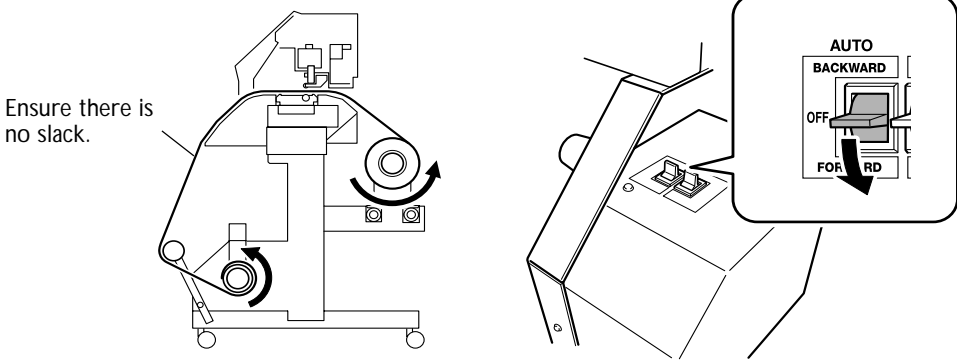

Take-up with inward curl

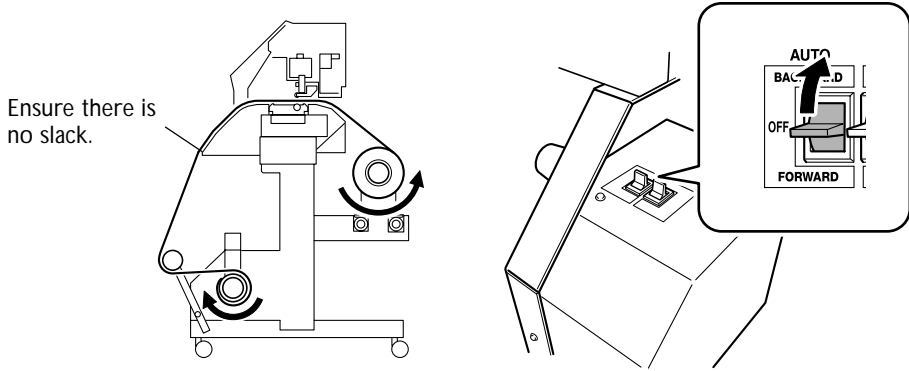

5 W 1839mm

Press **ENTER**.
Making the setting is complete when the screen shown in the figure (the top menu) appears.

When you begin take-up, take care to ensure that the end of the media does not become rolled or creased.

To Take up Media Manually

You can take up media by using the MANUAL switch. However, never operate the MANUAL switch while the loading lever is pulled back. Doing so may cause the media to be pulled with excessive force, actuating the protective feature and resulting in an error.

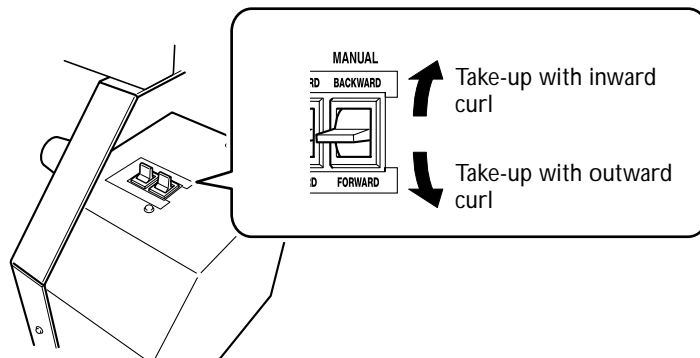

Removing Taken-up Media

⚠ CAUTION Removal of taken-up roll media from the unit is a task which must be carried out by two or more persons. If dropped, such items may cause injury.

- 1 Cut off the media.
☞ P.33, "How to Cut Off Media"
- 2 Support the paper tube to prevent it from falling.
- 3 Loosen the arm retaining screw and move the arm.
- 4 Detach the paper tube from the end caps.

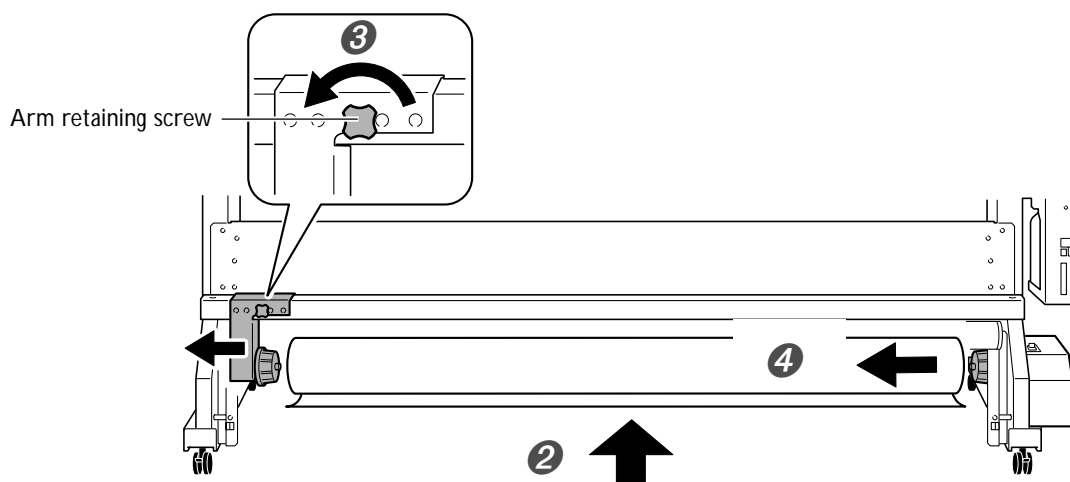

Chapter 4

Maintenance and Adjustment

4-1 Daily Care and Maintenance

Disposing of Discharged Ink

The drain bottle collects discharged fluid. Dispose of collected material before the bottle becomes full. The message shown in the figure appears when a certain amount of discharged fluid has collected in the bottle. Follow the procedure below to discard the discharged fluid.

CHECK
DRAIN BOTTLE

Press **ENTER**.

Resetting the discharged-fluid counter after disposal makes the message shown in the figure disappear.

1. Choose the [DRAIN BOTTLE] menu item.

1 MENU
SUB MENU

Press **MENU**.
Press **▼** several times.

2 SUB MENU
MAINTENANCE

Press **▶**.
Press **▲**.

3 MAINTENANCE
DRAIN BOTTLE

Press **▶**.
Press **▲**.

4 EMPTY
DRAIN BOTTLE

Press **ENTER**.
Preparations are complete when this screen appears.

2. Empty the bottle by discarding the discharged fluid.

⚠ CAUTION

Before you detach the drain bottle, be sure to wait for the screen to display "EMPTY DRAIN BOTTLE."

Failing to follow this procedure may cause discharged fluid to flow out of the tube and spill, soiling your hands or the floor.

Upper limit
Discard before
this is reached.

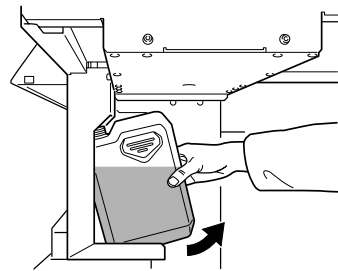
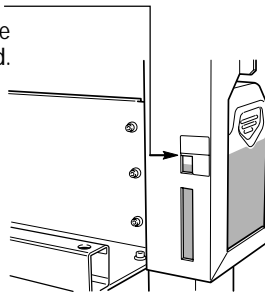

3. Attach the emptied bottle and reset the discharged-fluid count.

1

Attach the emptied bottle.

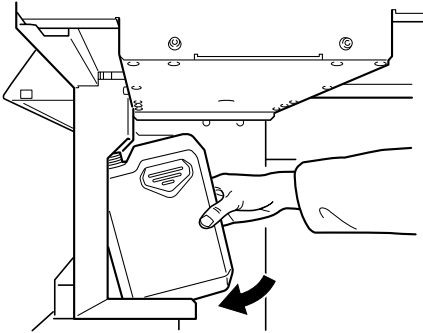

2

RESET DRAIN
COUNTER ↵

Press **ENTER**.

3

MAINTENANCE
DRAIN BOTTLE ↵

Press **ENTER** a second time.

4

W 1839mm
SETUP SHEET
◀▶ ROLL

Press **MENU**.

Press **◀** to go back to the original screen.

⚠WARNING Never place discharged fluid near open flame. Doing so may cause fire.

⚠CAUTION To store discharged fluid temporarily, place it in the included drain bottle or in a durable sealed container such as a metal can or polyethylene tank, and cap tightly. Any spillage or vapor leakage may cause fire, odor, or physical distress.

Dispose of discharged fluid properly, in accordance with the laws in effect in your locale. Discharged fluid is flammable and contains toxic ingredients. Never attempt to incinerate discharged fluid or discard it with ordinary trash. Also, do not dispose of it in sewer systems, rivers, or streams. Doing so may have an adverse impact on the environment.

Cleaning

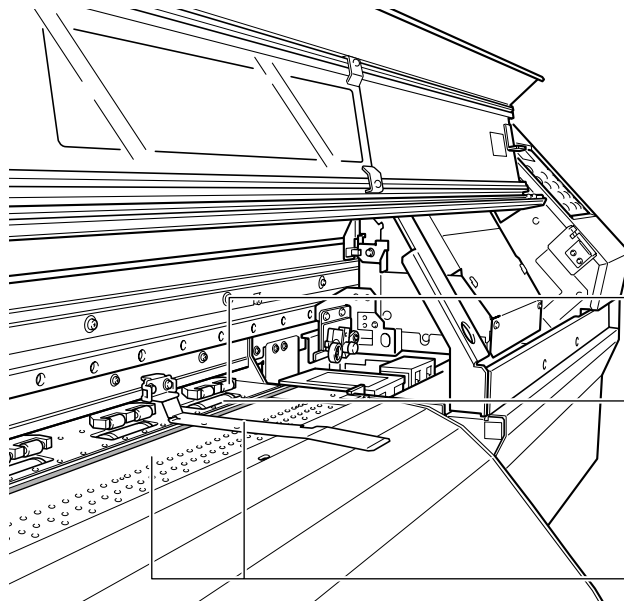

Pinch rollers

Periodically wipe away any grime. Failure to clean properly may result in the transfer of grime to the surface of media.

Grit rollers

Remove buildup of media and other material using a brush. Never use a metal brush.

Wipe away any buildup of ink or grime on the media path.

⚠ WARNING Never use gasoline, alcohol, thinner, or any other flammable material. Doing so may cause fire.

⚠ CAUTION Before attempting cleaning, switch off the sub power and wait until the platen and dryer cool (approximately 30 minutes). Sudden movement of the machine may cause injury, or hot components may cause burns.

- This machine is a precision device, and is sensitive to dust and dirt. Perform cleaning on a daily basis.
- Clean by wiping with a cloth moistened by neutral detergent diluted with water then wrung dry.
- Never attempt to oil or lubricate the machine.

Care and Maintenance of the Print Heads

Daily Care and Maintenance

Perform maintenance using the machine's head cleaning feature.

☞ P. 37, "Printing Tests and Cleaning," p. 54, "When Head Cleaning Is Not Effective"

Periodic Care and Maintenance

Periodic care is essential to ensuring optimal printing at all times. Based on your frequency of use, periodically clean the heads using a cleaning kit.

☞ P. 56, "Cleaning the Heads Using the Cleaning Kit"

Note: The print heads are components that wear out. Periodic replacement is required, with the frequency of replacement depending on use. Purchase them from your authorized Roland DG Corp. dealer.

4-2 When Head Cleaning Is Not Effective

Performing More Powerful Cleaning

When the problems such as dot drop-out are not cleared up by the "normal cleaning," try the more forceful "medium cleaning" or the even more forceful "powerful cleaning." Note, however, that this consumes more ink than "normal cleaning," and too-frequent use may damage the print heads themselves. Avoid using it more than necessary. In the same way as for normal cleaning, choose and clean only the group of a head that are incapable of correct printing.

1. Choose "medium cleaning" or "powerful cleaning."

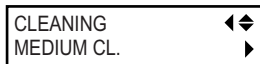

Press **CLEANING**.
Use **▲** **▼** to choose "MEDIUM CL." or "POWERFUL CL."

2. Specify the head group to clean.

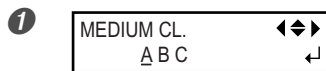

Press **▶**.

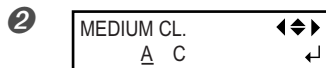

Use **◀** **▶** to choose the group of heads that is not to be cleaned.
Use **▲** **▼** to get rid of the group display.

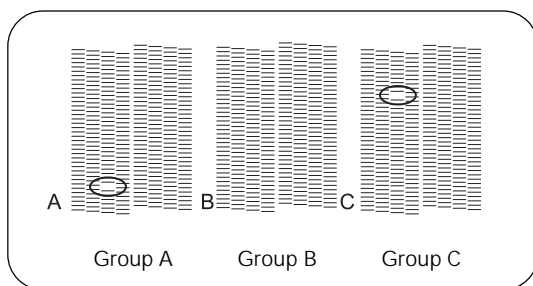

Repeat this procedure to display the groups of only the heads that require cleaning.

Of groups A through C, cleaning is performed only for the groups displayed.

Printing-test results

3. Start cleaning.

1 Press **ENTER**.
If You Chose "MEDIUM CL."

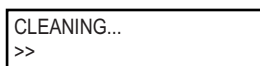

The screen shown in the figure appears, then cleaning starts.



When it finishes, the screen shown in the figure appears. Go on to Step 4.

If You Chose "POWERFUL CL."



The screen shown in the figure appears. Go on to Step 2.

2 Check the drain bottle.

If the amount of discharged fluid is near the upper-limit line, then remove the bottle, discard the collected fluid, and reattach the bottle.

☞ P. 50, "Disposing of Discharged Ink," step 2

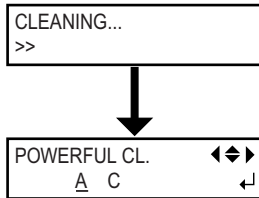
3

Press **ENTER**.

The screen shown in the figure appears, then cleaning starts.

When it finishes, the screen shown in the figure appears again. Go on to Step **4**.

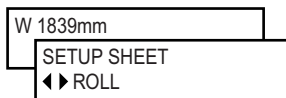
4

Press **MENU**.

Press **◀** to go back to the original screen.

When Powerful Cleaning Is Not Effective

If problems such as dot drop-out persist even after you have performed powerful cleaning several times, then use the cleaning kit to clean the heads. Such cleaning can be effective when carried out periodically, according to the frequency of use.

☞ P. 56, "Cleaning the Heads Using the Cleaning Kit"

4-3 Cleaning the Heads Using the Cleaning Kit

When the Cleaning Kit Becomes Necessary

Periodic Care and Maintenance

Use the cleaning kit to perform head-cleaning periodically, according to the frequency of use.

When Dot Drop-out or the Like Occur Frequently

When the machine's head-cleaning feature does not correct the problem, clean the heads using the cleaning kit.

- If you use up the cleaning kit, purchase a new one from your authorized Roland DG Corp. dealer.
- The print heads are components that wear out. Periodic replacement is required, with the frequency of replacement depending on use. Purchase them from your authorized Roland DG Corp. dealer.

How to Perform Cleaning

Important Notes on This Procedure

- Before attempting this operation, remove any media.
- To prevent the heads from drying out, finish this procedure in 30 minutes or less.
- A warning beep sounds after 30 minutes. At this time, stop work, close the front cover, and press **ENTER**. When the head-protection operation finishes, restart the procedure from the beginning.
- Never use any implement other than the included cleaning stick. Cotton swabs or other lint-producing items may damage the heads.
- Never touch the nozzle surface of the heads.
- Stroke the sponges very gently, applying as little pressure as possible. Never rub, scrape, or crush them.

⚠ CAUTION Be sure to perform operations as specified by these instructions, and never touch any area not specified in the instructions. Sudden movement of the machine may cause injury.

1. Change to the print-head manual-cleaning mode.



Press .
Press  several times.



Press .
Press .



Press .



Press .

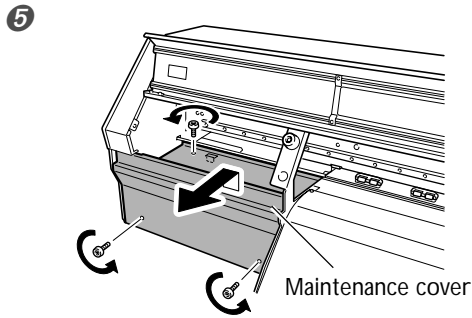

Open the front cover and remove the maintenance cover.

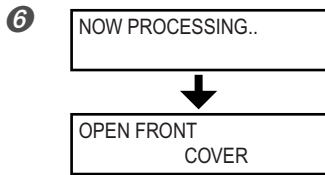

Close the front cover and press .
The print-head carriage moves to the left side of the machine, and then the screen shown in the figure appears.

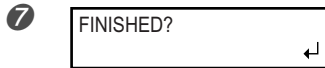

Open the front cover.
Preparations are complete when this screen appears.

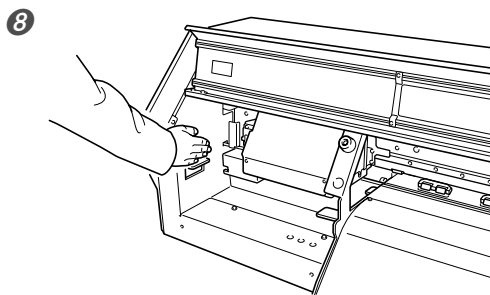

Touch the location shown in the figure to discharge any static electricity.

2. Clean using the cleaning stick. Be especially careful to clean away any fibrous dust (lint).

Clean in the sequence shown in the figure below.

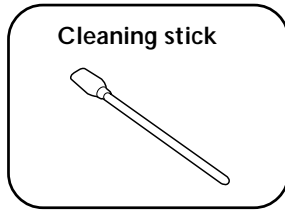

Be sure to clean using one of the included cleaning sticks.



Never touch the nozzle surface.
Clean only the metal frame.

Gently stroke the sponge.
Never rub with force.

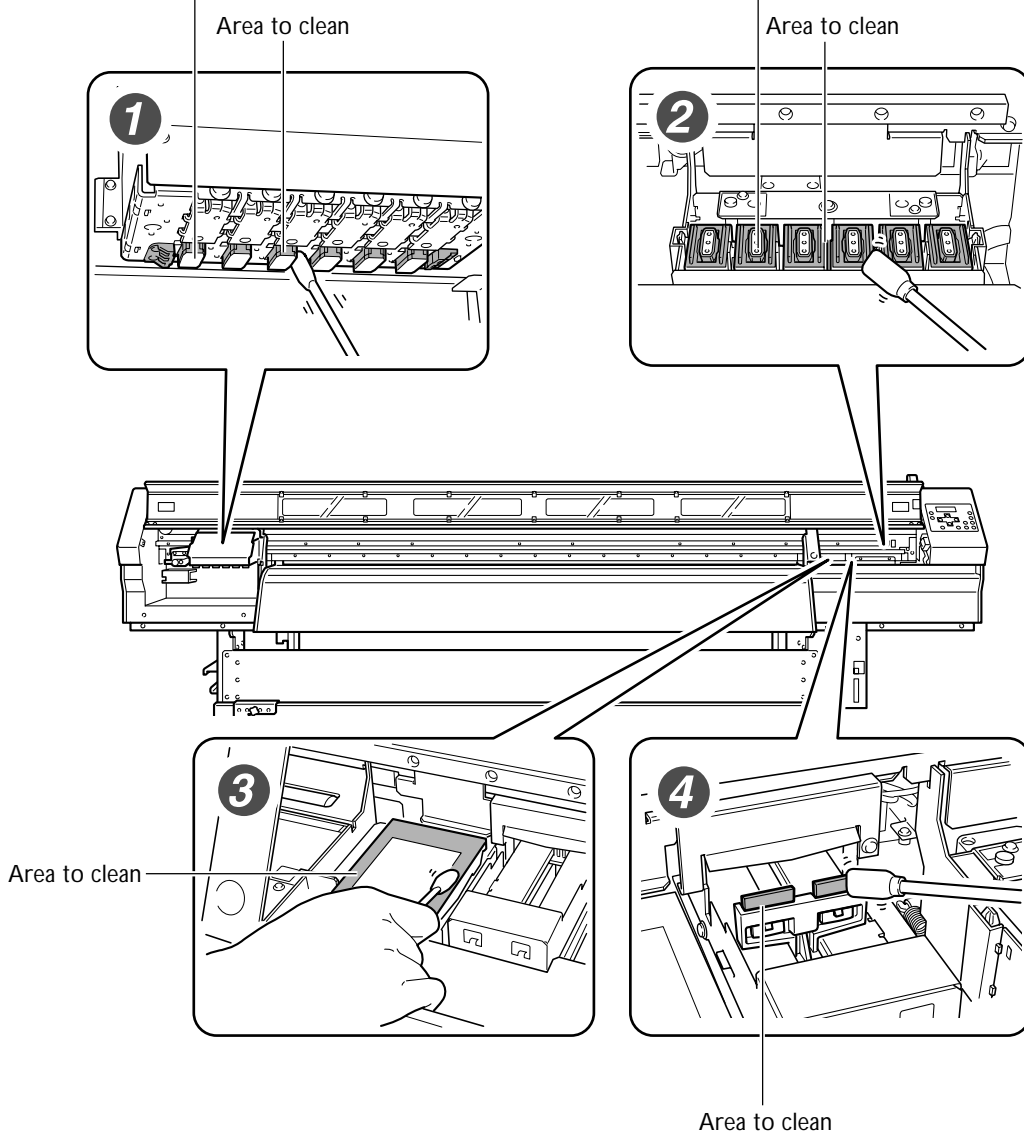

3. Quit the manual cleaning mode.

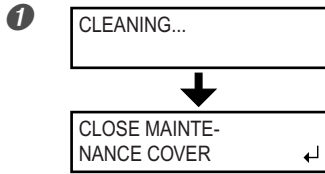

Close the front cover.
Press **ENTER**.

The print-head carriage moves to the right side of the machine, and then the screen shown in the figure appears.

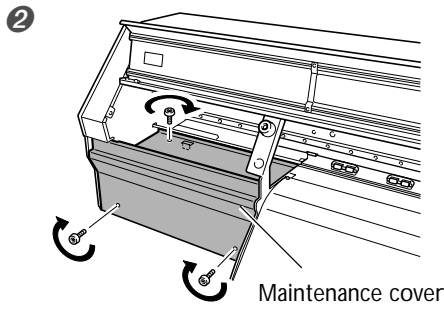

Open the front cover and attach the maintenance cover.

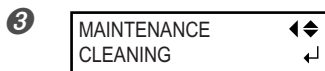

Close the front cover.
Press **ENTER**.

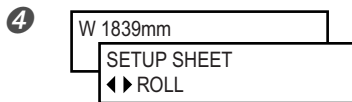

Press **MENU**.
Press **←** to go back to the original screen.

4. Perform a printing test to verify the results of the procedure.

Perform a printing test to check the results.
Perform cleaning several times as required.

☞ P. 37, "Printing Tests and Cleaning"

4-4 Replacing Consumable Parts

Replacing the Wipers

The wipers are components that you use when cleaning the print heads. When the screen displays a message like the one shown, it means the item needs to be replaced. Replace with new items.



Press **ENTER**.

Important Notes on This Procedure

- > To prevent the heads from drying out, finish this procedure in 30 minutes or less.
- > A warning beep sounds after 30 minutes. At this time, stop work, attach the front cover, and press **ENTER**. When the head-protection operation finishes, restart the procedure from the beginning.

CAUTION Be sure to perform operations as specified by these instructions, and never touch any area not specified in the instructions. Sudden movement of the machine may cause injury.

1. Display the [REPLACE WIPER] menu item.



Press **MENU**.
Press **▼** several times.

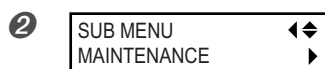

Press **▶**.
Press **▲**.

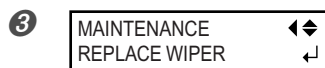

Press **▶**.
Press **▼**.



Press **ENTER**.

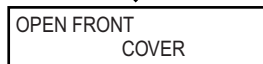

The print-head carriage moves to a location permitting wiper replacement, and then the screen shown in the figure appears.

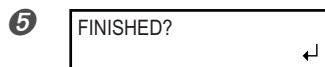

Open the front cover.
Preparations are complete when this screen appears.

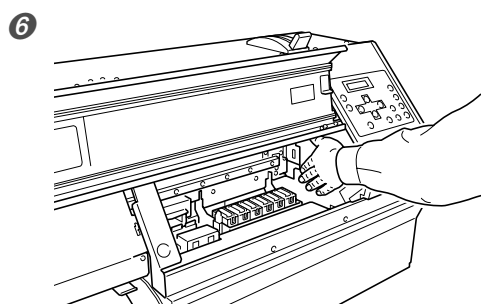

Touch the location shown in the figure to discharge any static electricity.

2. Replace the wipers. Use the included tweezers.

①

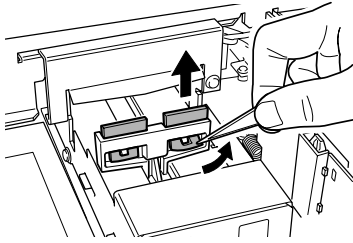

Detach the old wipers.
Detach the hook and pull up and out.

②

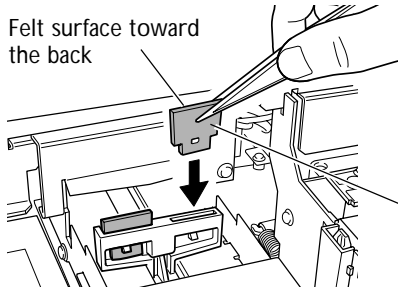

Insert the new wipers.

③

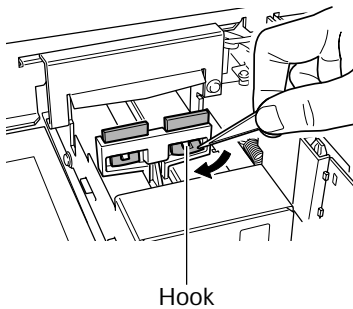

Attach the hook.

3. Quit the [REPLACE WIPER] menu item.

①

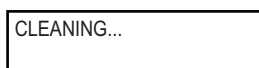

Close the front cover.

Press **ENTER**.

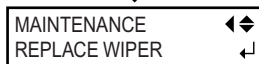

After the process to quit the [REPLACE WIPER] menu item ends, the screen shown in the figure appears.

②

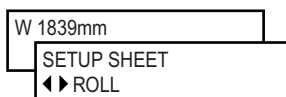

Press **MENU**.

Press **←** to go back to the original screen.

③ Perform a printing test to verify the results of the procedure.

☞ P. 37, "Printing Tests and Cleaning"







Replacing the Separating Knife

If the separating knife becomes dull, replace it with the included replacement knife.

⚠ CAUTION Be sure to perform operations as specified by these instructions, and never touch any area not specified in the instructions. Sudden movement of the machine may cause injury.

⚠ CAUTION Never touch the tip of the separating knife with your fingers. Doing so may result in injury.

1. Enter the blade replacement mode.

- | | | |
|---|------------------------------------|---|
| 1 | MENU ◀▶
SUB MENU ▶ | Press  .
Press  several times. |
| 2 | SUB MENU ◀▶
MAINTENANCE ▶ | Press  .
Press  . |
| 3 | MAINTENANCE ◀▶
REPLACE KNIFE ◀↓ | Press  .
Press  several times. |
| 4 | NOW PROCESSING.. | Press  . |
- ↓
- | | |
|------------------|--|
| OPEN FRONT COVER | The print-head carriage moves to a location permitting blade replacement, and then the screen shown in the figure appears. |
|------------------|--|

- | | | |
|---|--------------|--|
| 5 | FINISHED? ◀↓ | Open the front cover.
Preparations are complete when this screen appears. |
|---|--------------|--|

2. Replace the separating knife.

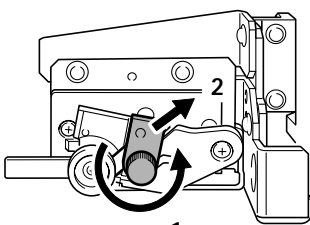
- | | | |
|---|---|------------------------------|
| 1 |  | Remove the separating knife. |
|---|---|------------------------------|

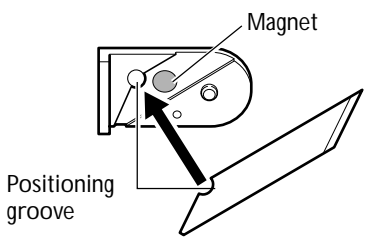
- | | | |
|---|---|--|
| 2 |  | Install a new knife.
The knife is secured in place by the magnet. |
|---|---|--|

3

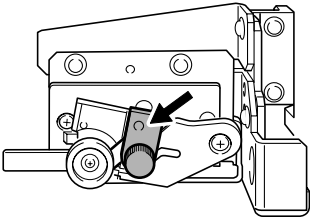

Slowly insert it into the groove.

4

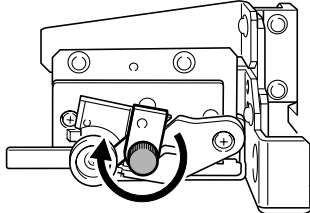

Tighten the screw.
Take care to ensure that the knife does not slip out of position at this time.

3. Quit the [REPLACE KNIFE] menu item.

1



Close the front cover.

Press **ENTER**.

2

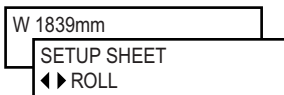

Press **MENU**.

Press **←** to go back to the original screen.

4-5 When Not in Use for a Prolonged Period

Keep Performing Maintenance

Switch On the Power Once a Month

Switch on the sub power once a month. When you turn on the power, the machine automatically performs some operations such as those to keep the print heads from drying out. Allowing the machine to stand completely unused for a prolonged period may damage the print heads, so be sure to switch on the power to perform these automatic operations.

Keep at a Constant Temperature and Relative Humidity

Even when the machine is not in use, keep it at a temperature of 5 to 40°C (41 to 104°F) and a relative humidity of 20 to 80% (with no condensation). Temperatures that are too high may degrade the ink and cause malfunction. Temperatures that are too low may cause the ink to freeze and damage the heads.

Alarm Feature

PRESS THE POWER
KEY TO CLEAN

This feature is to remind you to switch on the sub power once a month. When the machine remains unused for about one month, this screen appears and a warning beep sounds. If this screen appears, switch on the sub power. When maintenance operations finish, switch off the sub power.

This feature operates when the printer's main power is turned on. We recommend leaving on just the main power to the printer even when the machine is to remain out of use for a prolonged period.

Important Note on Draining Ink

This machine has features for draining internal ink and for performing washing using cleaning cartridges, but they should never be used except in special cases. Allowing the machine to stand without ink for a prolonged period may damage the heads, even if internal washing is performed. Once ink has been filled, then as a rule the ink should never be drained.

4-6 When Moving the Unit

Procedures from Preparing to Move Through Reinstalling

To move the machine, you must completely drain all ink inside the machine and secure the print heads in place with packing materials to protect them. Attempting to move the machine without first doing this may result in damage to internal components due to leaking ink or damage to the heads.









This operation requires eight unused SOL INK cleaning cartridges. Have these on hand before you start.

For information on how to remove and attach the various items, refer to the Setup Guide.

Important Notes on Moving

- Be sure to use SOL INK cleaning cartridges. Use of any other type may result in breakdown.
- Once the preparations for moving are complete, move the machine and fill it with ink with as little delay as possible. Allowing the machine to stand without ink may damage the heads.
- When moving the machine, keep it at a temperature between 5 to 40°C (41 to 104°F) and at relative humidity between 20 to 80% (with no condensation). Failure to do so may result in breakdown.
- Handle the machine with care when moving, keeping it level (not tilted at an angle) and preventing it from striking other objects.

1. Drain the ink and wash the interior.

- | | | |
|----------|--------------------------------|--|
| 1 | MENU
SUB MENU | Press  .
Press  several times. |
| 2 | SUB MENU
INK CONTROL | Press  .
Press  twice. |
| 3 | INK CONTROL
HEAD WASH | Press  .
Press  twice.
Press  . |
| 4 | CLEANING LIQUID
IS REQUIRED | Make sure the cleaning fluid is ready.
Press  . |
| 5 | CHECK
DRAIN BOTTLE | Discard the discharged ink in the drain bottle.
Be sure to discard the discharged ink. |
| 6 | WASHING HEAD...
>> | Attach the drain bottle and press  .
The screen shown in the figure appears, and cleaning starts. |

- 7** Thereafter, follow the on-screen instructions to carry out the operations.
After cleaning has finished, the sub power is automatically switched off.

☞ P. 50, "Disposing of Discharged Ink," p. 96, "Draining Ink and Performing Internal Washing"

2. Secure the print heads in place.

- ① Remove the drain bottle and detach the drain-bottle stand. Then attach the drain-tube cover.
- ② Flip the loading lever to the rear.
- ③ Secure the print heads in place using the packing material.
- ④ Detach the roll media from the media holders.
- ⑤ Detach the media holders and the shafts.
If necessary, also detach the dancer roller, rail slider, and stand legs etc.
The machine is now ready to be moved.

3. Immediately move the machine and fill it with ink.

- ① Once the preparations are complete, move the machine with as little delay as possible.
- ② Immediately reinstall the machine and fill with ink.
To reinstall and fill with ink, refer to the Setup Guide. When filling with ink, you use the cleaning cartridges again.

Chapter 5

Feature Reference

5-1 Pausing or Canceling Printing

Canceling Printing Before It Finishes

Procedure

- 1 Press **PAUSE**.
- 2 Hold down **SET UP** for one second or longer.
- 3 Stop sending printing data from the computer.

Description

PAUSE pauses printing. Pressing **PAUSE** a second time here resumes printing, but a horizontal stripe is produced at the location where printing was stopped. We do not recommend resuming printing.

5-2 Setting the Printing Position and Margins

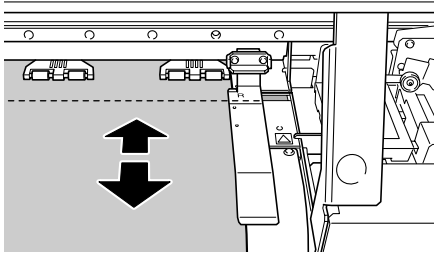

Shifting the Print-start Position Forward or Backward

Procedure



Use   to move the media.

Description

You can shift the print-start position forward or backward by using  and  to move the media. Note, however, that with some media types, such as heavy or sticky media, performing continuous movement for one minute or longer may trigger a protective feature and result in an error. Also, never use  in the following cases.

➤ When you're using the take-up system

The take-up system may pull the media with undue force, resulting in an error or malfunction.

➤ Before or after executing feed correction

Slackness in the roll media can make it impossible to obtain reliable correction results. Also, slackness in the roll media after feed correction may cause slippage in the media's movement distance during printing, resulting in horizontal stripes.

☞ P. 85, "Performing Feed Correction to Alleviate Horizontal Bands and the Like"

Shifting the Printing Position to the Left

Procedure

- 1
- 2
- 3
- 4

BASE POINT

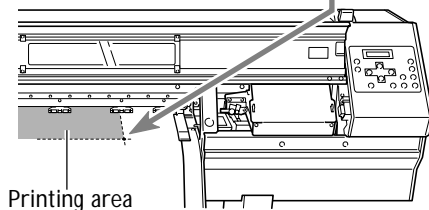
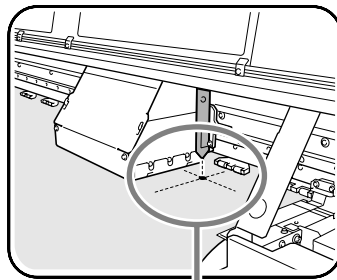

Use   to move the heads.

Press .

If the front cover is open, then close it.

Press .

Description

You can shift the printing position to the left by using **BASE POINT**. Note, however that this setting must be made for each individual page. When the printing of one page finishes, the left-right positioning returns to its default value. When the position has been set, **BASE POINT** lights up and the screen displays the printable width at the set position.

This feature is also available when printing various test patterns, and can help you use media with less waste. Note, however, that the left and right positions are not restored to their defaults for test patterns.

Expanding the Printing Area by Reducing the Margins

Procedure

- | | | |
|---|---|---|
| 1 | MENU ◀▶
SUB MENU ▶ | Press MENU .
Press ▼ several times. |
| 2 | SUB MENU ◀▶
SIDE MARGIN ▶↵ | Press ▶ .
Press ▼ several times. |
| 3 | SIDE MARGIN ◀▶
10 mm ▶ 5 mm ↵ | Press ▶ .
Use ▲ ▼ to select [5 mm]. |
| 4 | SETUP SHEET
◀▶ ROLL | Press ENTER to enable the setting.
The settings are saved and the screen shown in the figure appears. |

Description

This makes the setting for distance from the left or right media clamp to the corresponding left or right edge of the printing area. You can select either "5 mm" or "10 mm." Setting this to "5 mm" lets you expand the printing area.

☞ P.119 "Printing Area and Margins"

Note, however, that when you're using transparent media, setting this to "5 mm" may result in printing on top of the media clamps.

Changing the setting while **SET UP** is lighted makes **SET UP** go dark. To start printing, press **SET UP** once more and redo the preparations for printing.

Default Setting

[SIDE MARGIN]: 10 mm

5-3 Accommodating Various Kinds of Media

Using Transparent Media

Procedure

1. Load transparent media to the printer.

1 Refer to "2-2 Loading and Cutting Off Media" and load the media on the machine.

2. Set the media type to "CLEAR."

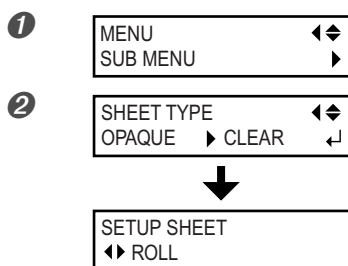

Press **MENU**.
Press **▼** several times.

Press **▶** twice.
Use **▲** **▼** to select "CLEAR."
Press **ENTER** to enable the setting.

The screen shown in the figure appears.

3. Make the setting for the media width.

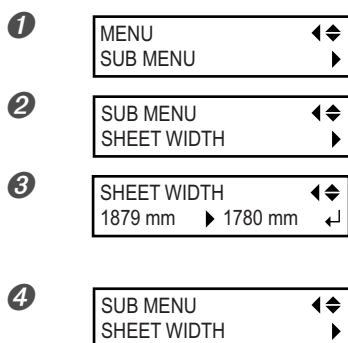

Press **MENU**.
Press **▼** several times.

Press **▶**.
Press **▼**.

Press **▶**.
Use **▲** **▼** to enter the media width.
Press **ENTER** to enable the setting.

Press **◀** to go back to the previous screen.

4. Make the setting for the location of the right edge of the media.

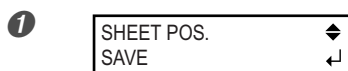

Press **▼**.
Press **▶**.

The print heads move to the position now set.

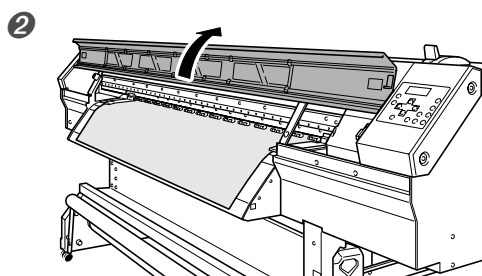

Open the front cover.

5-3 Accommodating Various Kinds of Media

3

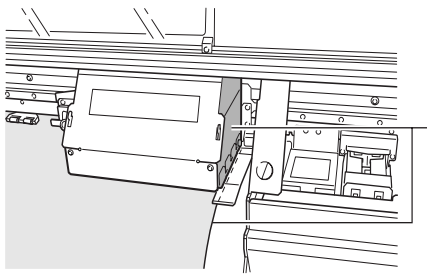

Use ◀ ▶ to move the heads.

Align this surface with the edge of the media.

4

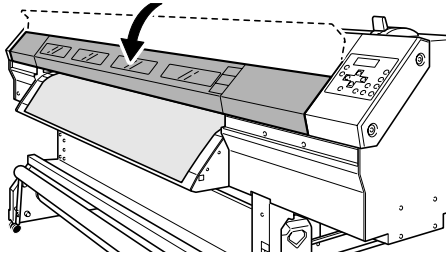

After positioning, close the front cover.
Press **ENTER** to enable the setting.

5

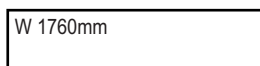

Press **MENU**.
Press ◀ to go back to the original screen, then
press **SET UP**.

The top menu appears.

Description

The media width can be sensed automatically for opaque media, but not for transparent media. This means that the width and mounted location of the media must be set manually. Incorrect settings may cause ink to be applied at locations where no media is present.

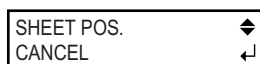

To quit making settings at the [SHEET POS.] menu item, use ▼ to select "CANCEL," then close the front cover and press **ENTER**.

Note that to keep the heads from drying out, the [SHEET POS.] menu item ends automatically after a certain interval, even if you're still making settings there.

The settings for the media width and start position made here are effective only when [SHEET TYPE] is set to "CLEAR." Selecting "OPAQUE" disables the settings, although the setting values are saved in memory. Choosing "CLEAR" again enables the values set previously.













Default Setting

[SHEET TYPE]: OPAQUE

[SHEET WIDTH]: 1879 mm (XJ-740) , 1625 mm (XJ-640), 1371 mm (XJ-540)

Printing Hard-to-dry Media

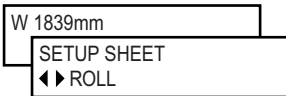
Procedure

- 1  Press .
Press  several times.
- 2  Press .
Press  several times.
- 3  Press .
Use   to set the value.
Press .
- 4  Press .
Press  to go back to the original screen.

Description

You use this when ink dries poorly even when the print heater and dryer are used. Larger values produce progressively slower movement of the media, enabling you to extend the drying time accordingly. Printing time takes correspondingly longer.











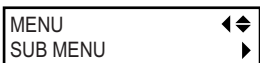

You can also make this setting on the computer. When you have made the setting on the computer, the computer's setting is used and the printer's setting is ignored.

Default Setting

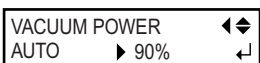
[SCAN INTERVAL]: OFF

Preventing Media from Coming Loose

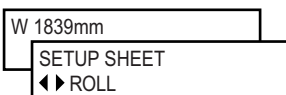
Procedure

- 1  Press .
Press  several times.
- 2  Press .
Press  several times.
- 3  Press .
Use   to set the value.
Press  to enable the setting.
- 4  Press .
Press  to go back to the original screen.

Description

The platen uses suction to grip the media and keep it stable. When media comes loose from the platen because it is warped or wrinkled, increasing the suction force may help correct the problem. Conversely, when the media is flimsy and cannot move smoothly, reducing the suction force may help.

When set to "AUTO," the suction force is automatically adjusted to the optimal level for the media width.

You can also make this setting on the computer. When you have made the setting on the computer, the computer's setting is used and the printer's setting is ignored.

Default Setting

[VACUUM POWER]: AUTO

Speeding Up Printing for Narrow Media

Procedure

- 1**

MENU ◀◆▶
 SUB MENU ▶

Press  .

Press  several times.

- 2**

SUB MENU ◀◆▶
 FULL WIDTH S ▶



Press  .

Press  several times.

- 3**

FULL WIDTH S ◀◆▶
 FULL ▶ OFF ◀◆▶

Press  .

Use   to select "SHEET" or "OFF."

Press  to enable the setting.

- 4**

W 1839mm
 SETUP SHEET
 ◀◆▶ ROLL

Press  .

Press  to go back to the original screen.

Description

This shortens printing time by reducing the width of head movement to the minimum necessary. This is effective when the width of the media or the printing data is narrow.

"SHEET" matches the range of head movement to the width of the media.

"OFF" matches the range of head movement to the printing data. Movement is limited to the minimum amount necessary, and this can be expected to yield the fastest printing. Note, however, that because the speed of media movement is no longer constant, colors may be uneven.

"FULL" makes the speed of media movement constant at all times.

Default Setting

[FULL WIDTH S]: FULL

Preventing Soiling of the Media and Dot Drop-out During Printing

Procedure

- 1**

MENU ◀◆▶
 SUB MENU ▶

Press  .

Press  several times.

- 2**

SUB MENU ◀◆▶
 PERIODIC CL. ▶

Press  .

Press  several times.

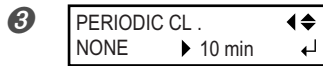

Press .

Use to select a value from "10 min" to "990 min," or "PAGE."

Press to enable the setting.



Press .

Press to go back to the original screen.

Description

Ink tends to collect on the surface of the heads when you use media prone to buildup of static charge, when the ambient temperature is low, or when the head height is set to "HIGH." Under some conditions, this ink may be transferred to the media or cause dot drop-out. Use this feature at such times. The ink buildup is removed as printing is performed.

When this is set to "PAGE," automatic cleaning is performed every time before printing starts.

When this is set to a value from "10 min" to "990 min," automatic cleaning is performed when the cumulative printing time reaches the value you set here.

When this is set to "NONE," no automatic cleaning is performed.

Using "PAGE" or a value from "10 min" to "990 min," results in longer printing times. Also, when this is set to a value from "10 min" to "990 min," printing pauses and so colors may be uneven.

☞ P. 81, "Adjusting Head Height to Match Media Thickness"

Default Setting

[PERIODIC CL.]: NONE

Using Sticky Media

Procedure



Press .

Press several times.



Press .

Press several times.



Press .

Use to select "ENABLE."

Press to enable the setting.



Press .

Press to go back to the original screen.

Description

Some types of media may tend to stick to the platen. Starting printing with the media sticking to the platen may make normal media feed impossible and cause the media to jam. When you're using such media, set the [MEDIA RELEASE] menu item to "ENABLE." This peels off the media if sticking before starting printing. Note, however, that media feed may be unstable when printing is performed after executing this operation. Leave this menu item set to "DISABLE" unless you specifically need to change it.

Default Setting

[MEDIA RELEASE]: DISABLE

How to Load Sheet Media

As with standard-size media, make sure of the following points when loading sheet media.

Procedure

1 If roll media is loaded, remove the media first.

2

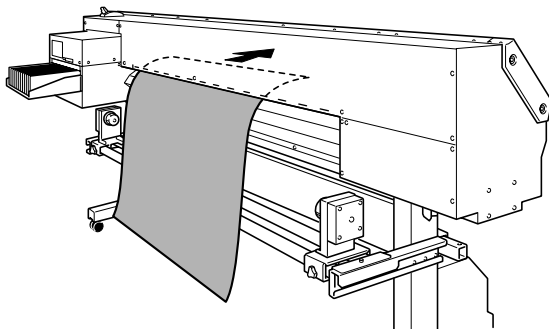

Pass the sheet media through the machine.

3

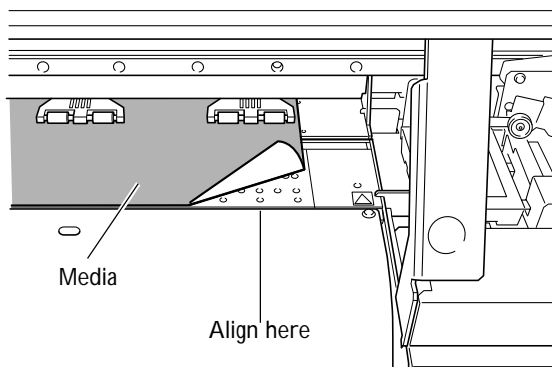

Align the front edge of the media with the location shown in the figure.

4

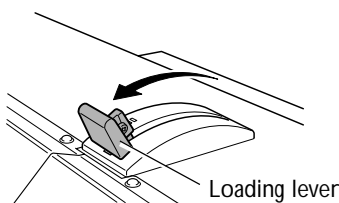

Pull back the loading lever.
The media is secured in place.

5 Attach the media clamps and close the front cover.

☞ P.32, "Loading Media," step 3

6



Use ◀ ▶ to select "ROLL."

7

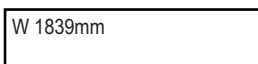













Press **SET UP**.
SET UP starts to flash. When initialization ends,
SET UP remains steadily lighted, and the printable
width is displayed.

5-4 Setting How the Printer Operates

Determining What Happens When an Ink Cartridge Is Empty

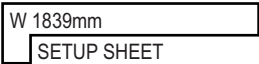
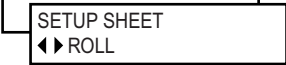
Procedure

-  Press .
Press  several times.
-  Press .
Press  twice.
-  Press  twice.
Use   to make the setting.
Press  to enable the setting.
- 
 Press .
Press  to go back to the original screen.

Description











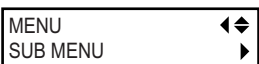



This lets you change, according to your purpose, the operation that takes place when an ink cartridge is empty. "STOP" immediately pauses operation when a cartridge becomes empty. Because pausing printing in progress may make colors uneven, it is best to ensure a sufficient amount of remaining ink before you begin printing. "CONT." (continue) is a mode in which operation is not automatically stopped. When a cartridge becomes empty, a warning beep sounds but printing doesn't stop. To replace the cartridge, you must either wait until printing ends or press  to pause printing. Note that operation does not stop even if ink runs out completely.

Default Setting

[EMPTY MODE]: STOP

Changing the Type of Ink

Procedure











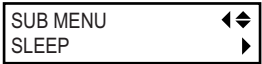

-  Press .
Press  several times.
-  Press .
Press  twice.
-  Press .
Press .
-  Press .
Use   to make the setting.
Press  to execute the setting.

Description

You use this when changing the type of ink. Selecting the type of ink used for replacement starts head-cleaning and ink-filling operations. Follow the on-screen instructions to insert and remove cartridges. This operation requires four unused SOL INK cleaning cartridges.

Setting the Interval until Activation of the Sleep Mode

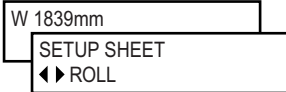
Procedure















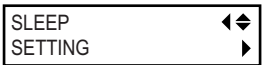

- 1  Press  .
Press  several times.
- 2  Press  .
Press  several times.
- 3  Press  twice.
Use   to make the setting.
Press  to enable the setting.
- 4  Press  .
Press  to go back to the original screen.

Default Setting

[INTERVAL]: 30min

Deactivating the Sleep Mode

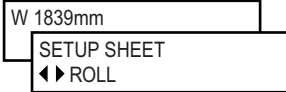
Procedure

- 1  Press  .
Press  several times.
- 2  Press  .
Press  several times.
- 3  Press  .
Press  .
- 4  Press  .
Use   to select "DISABLE."
Press  to enable the setting.
- 5  Press  .
Press  to go back to the original screen.











Default Setting

[SETTING]: ENABLE

Giving Priority Efficient Ink Use During Operation

Procedure

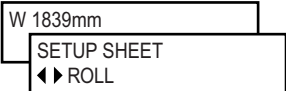
- 1  Press  .
Press  several times.

- 2  Press .
Press  several times.
- 3  Press .
Use   to select "ENABLE."
Press  to enable the setting.
- 4  Press .
Press  to go back to the original screen.

Description

This menu item is displayed only when using four-color inks (cyan, magenta, yellow, and black). It sets whether efficient ink use or image quality takes priority when you're performing bidirectional printing. Note, however, that some high-speed print modes may not be affected by this setting.

Setting this to "DISABLE" performs printing with priority given to image quality.











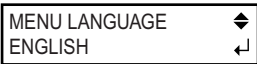

Setting this to "ENABLE" lets you use ink more efficiently, although image quality may be slightly coarser.

Default Setting

[ALTERNATE HEAD]: DISABLE

Changing the Menu Language and the Units of Measurement

Procedure

- 1  Hold down  and switch on the sub power.
Use   to select the display (menu) language.
Press .
- 2  Use   to select the measurement unit for length.
Press .
- 3  Use   to select to the measurement unit for temperature.
Press .

Description

This sets the language and units of measurement displayed on the printer's screen.

Default Setting







[MENU LANGUAGE]: ENGLISH

[LENGTH UNIT]: mm

[TEMP. UNIT]: °C

Returning All Settings to Their Initial Values

Procedure

- 1**  Press  .
Press  several times.
- 2**  Press  .
Press  several times.
Press  to execute.

Description

This menu item returns all settings to the same as their factory defaults. However, the settings for [MENU LANGUAGE], [LENGTH UNIT], and [TEMP. UNIT] are not returned to the factory defaults.

5-5 Optimizing Printing to Match Media Thickness

Adjusting Head Height to Match Media Thickness

Procedure



Press .
Press  several times.



Press .

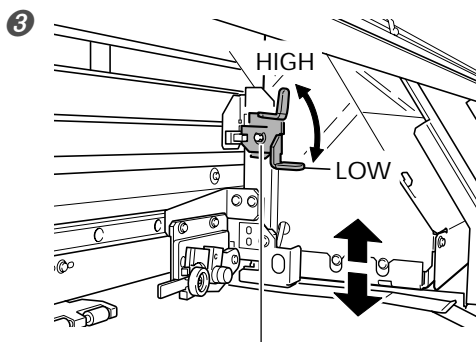

Open the front cover.
Move the lever to adjust the height of the head.



Moving the lever to "HIGH" makes a warning beep sound twice. Moving it to "LOW" makes the warning beep sound once.

Height-adjustment lever
Move firmly, until it stops.

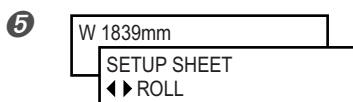

Close the front cover.
The print heads return to their original position and the screen shown in the figure appears.



Press .
Press  to go back to the original screen.

Description

Depending on the media, media may wrinkle or come loose from the platen during printing, increasing the chance of contact with the print heads. When you are using such media, adjust the head height to "HIGH."
Printing quality when the head height is set to "HIGH" may be coarser or otherwise lower than when set to "LOW." If this happens, refer to the pages indicated below.

☞ P. 74, "Preventing Soiling of the Media and Dot Drop-out During Printing," p. 82, "Correcting for Misalignment in Bidirectional Printing," p. 83, "Correcting for Misalignment in Bidirectional Printing More Precisely"

Default Setting

[HEAD HEIGHT]: LOW

Correcting for Misalignment in Bidirectional Printing

Procedure

1. Print a test pattern.

1. MENU ◀▶
ADJUST BI-DIR ▶
- Press **MENU**.
Press **▼**.
2. ADJUST BI-DIR ◀▶
TEST PRINT ↵
- Press **▶**.
Press **ENTER** to start printing.

2. Read the correction values from the test pattern.

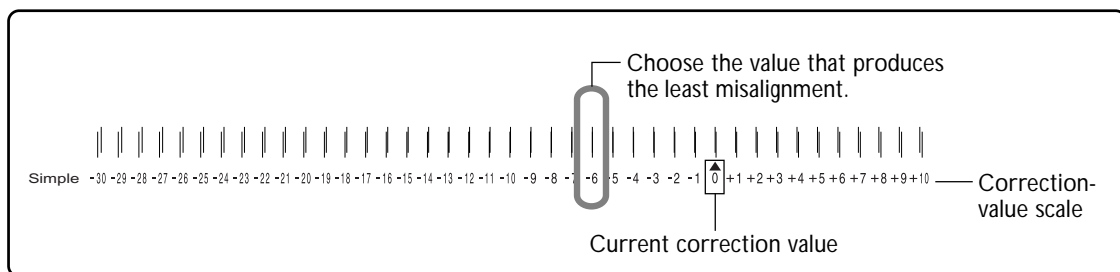

Test pattern

3. Enter the correction values that you read.

1. ADJUST BI-DIR ◀▶
SIMPLE SETTING ▶
- Press **▼**.
2. SIMPLE SETTING ◀▶
0 ▶ -6 ↵
- Press **▶**.
Use **▲** **▼** to set the correction values.
Press **ENTER** to enable the setting.

4. Go back to the original screen.

- W 1839mm
- SETUP SHEET
◀▶ ROLL
- Press **MENU**.
Press **◀** to go back to the original screen.

Description

The bidirectional-printing mode (in which the heads perform printing during both their outbound pass and return pass) offers the advantage of being able to shorten printing times, but subtle misalignment occurs during the outbound and return passes. The procedure to correct this and eliminate misalignment is bidirectional correction. This misalignment varies according to the head height and the thickness of the media, so we recommend performing correction to match the media you're using.

Correcting for Misalignment in Bidirectional Printing More Precisely

Procedure

1. Print a test pattern.

- | | | | | | |
|--|----------------|----|----------------|---|--|
| <p>1</p> <table border="1" style="border-collapse: collapse; width: 150px;"> <tr> <td style="padding: 2px;">MENU</td> <td style="text-align: right; padding: 2px;">◀▶</td> </tr> <tr> <td style="padding: 2px;">ADJUST BI-DIR</td> <td style="text-align: right; padding: 2px;">▶</td> </tr> </table> | MENU | ◀▶ | ADJUST BI-DIR | ▶ | <p>Press .</p> <p>Press .</p> |
| MENU | ◀▶ | | | | |
| ADJUST BI-DIR | ▶ | | | | |
| <p>2</p> <table border="1" style="border-collapse: collapse; width: 150px;"> <tr> <td style="padding: 2px;">ADJUST BI-DIR</td> <td style="text-align: right; padding: 2px;">◀▶</td> </tr> <tr> <td style="padding: 2px;">DETAIL SETTING</td> <td style="text-align: right; padding: 2px;">▶</td> </tr> </table> | ADJUST BI-DIR | ◀▶ | DETAIL SETTING | ▶ | <p>Press .</p> <p>Press .</p> |
| ADJUST BI-DIR | ◀▶ | | | | |
| DETAIL SETTING | ▶ | | | | |
| <p>3</p> <table border="1" style="border-collapse: collapse; width: 150px;"> <tr> <td style="padding: 2px;">DETAIL SETTING</td> <td style="text-align: right; padding: 2px;">◀▶</td> </tr> <tr> <td style="padding: 2px;">TEST PRINT</td> <td style="text-align: right; padding: 2px;">↵</td> </tr> </table> | DETAIL SETTING | ◀▶ | TEST PRINT | ↵ | <p>Press .</p> <p>Press to start printing.</p> |
| DETAIL SETTING | ◀▶ | | | | |
| TEST PRINT | ↵ | | | | |

2. Read the correction values from the test pattern.

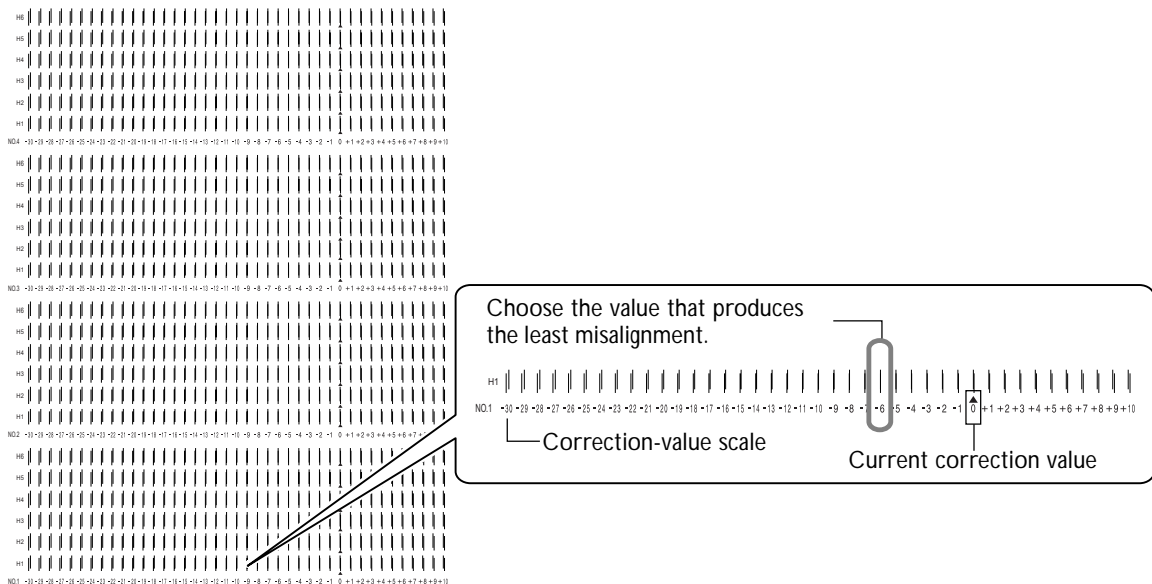









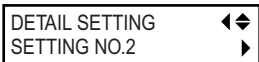

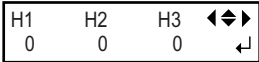

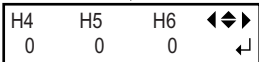







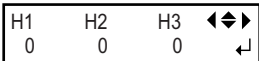

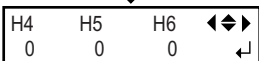





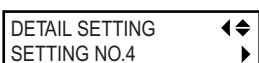

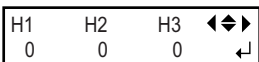
Test pattern

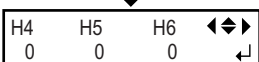
3. Enter the correction values that you read.

Enter the corresponding correction values for H1 through H6.

- | | | | | | | | | | | | | | | | | | |
|--|----------------|----|--------------|----|-----------------|---|---|---|----|----|----|----|---|---|---|---|--|
| <p>1</p> <table border="1" style="border-collapse: collapse; width: 150px;"> <tr> <td style="padding: 2px;">DETAIL SETTING</td> <td style="text-align: right; padding: 2px;">◀▶</td> </tr> <tr> <td style="padding: 2px;">SETTING NO.1</td> <td style="text-align: right; padding: 2px;">▶</td> </tr> </table> | DETAIL SETTING | ◀▶ | SETTING NO.1 | ▶ | <p>Press .</p> | | | | | | | | | | | | |
| DETAIL SETTING | ◀▶ | | | | | | | | | | | | | | | | |
| SETTING NO.1 | ▶ | | | | | | | | | | | | | | | | |
| <p>2</p> <table border="1" style="border-collapse: collapse; width: 150px;"> <tr> <td style="padding: 2px;">H1</td> <td style="padding: 2px;">H2</td> <td style="padding: 2px;">H3</td> <td style="text-align: right; padding: 2px;">◀▶</td> </tr> <tr> <td style="padding: 2px;">0</td> <td style="padding: 2px;">0</td> <td style="padding: 2px;">0</td> <td style="text-align: right; padding: 2px;">↵</td> </tr> </table> <p style="text-align: center;">↑</p> <table border="1" style="border-collapse: collapse; width: 150px;"> <tr> <td style="padding: 2px;">H4</td> <td style="padding: 2px;">H5</td> <td style="padding: 2px;">H6</td> <td style="text-align: right; padding: 2px;">◀▶</td> </tr> <tr> <td style="padding: 2px;">0</td> <td style="padding: 2px;">0</td> <td style="padding: 2px;">0</td> <td style="text-align: right; padding: 2px;">↵</td> </tr> </table> | H1 | H2 | H3 | ◀▶ | 0 | 0 | 0 | ↵ | H4 | H5 | H6 | ◀▶ | 0 | 0 | 0 | ↵ | <p>Press .</p> <p>Use to select. Use to set the correction value.</p> <p>Press to finish making the settings for [SETTING NO.1].</p> |
| H1 | H2 | H3 | ◀▶ | | | | | | | | | | | | | | |
| 0 | 0 | 0 | ↵ | | | | | | | | | | | | | | |
| H4 | H5 | H6 | ◀▶ | | | | | | | | | | | | | | |
| 0 | 0 | 0 | ↵ | | | | | | | | | | | | | | |

- 3  Press .
- 4  Press 
 Use   to select. Use   to set the correction value.
Press  to finish making the settings for [SETTING NO.2].
- 5  Press .
- 6  Press 
 Use   to select. Use   to set the correction value.
Press  to finish making the settings for [SETTING NO.3].
- 7  Press .
- 8  Press 
 Use   to select. Use   to set the correction value.
Press  to finish making the settings for [SETTING NO.4].

4. Go back to the original screen.

-  Press 
Press  to go back to the original screen.







Description

This corrects, for each head, the minute misalignment that occurs in the bidirectional-printing mode. When further correction is required, such as when adjustment made using [SIMPLE SETTING] does not enhance printing, use [DETAIL SETTING] to make corrections for each head.

Performing Feed Correction to Alleviate Horizontal Bands and the Like

Procedure

1. Print a test pattern.

- ①  Press .
Press  several times.
- ②  Press .
Press  to start printing.





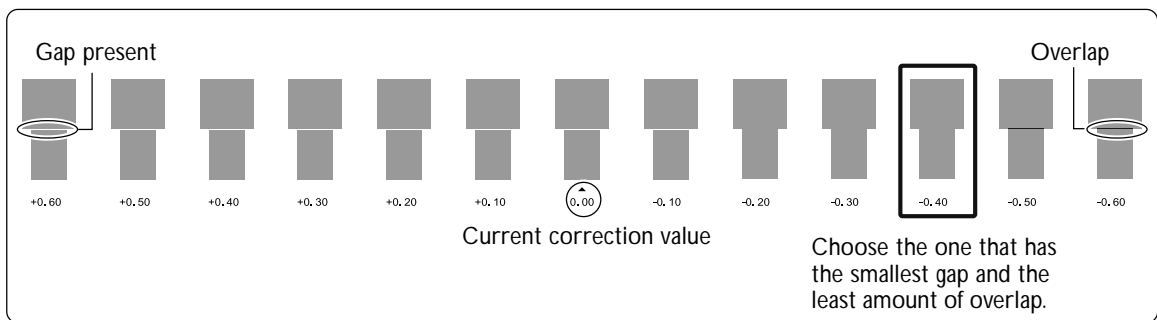

2. Read the correction values from the test pattern.

In the printing example shown below, "-0.40" becomes the correction value.





Test pattern

3. Enter the correction values that you read.

-  Press .
Press .
Use   to make the setting for the correction value.
Press  to enable the setting.

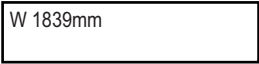
4. Go back to the original screen.

-  Press .
Press  to go back to the original screen.

Description

The movement distance of media experiences subtle changes due to the thickness of the media and the temperature of the media heating system. When the movement distance becomes discrepant, horizontal stripes are more likely to occur during printing. We recommend performing correction to match the media you're using and the media heating system. Also, perform the actual printing in an operating environment identical to that used for the test pattern.

5-5 Optimizing Printing to Match Media Thickness

To make the setting for the correction value even more accurate, we recommend carrying out the following before printing the test pattern.

- After loading the media, use  to feed out the media by about one meter.
 - ☞ P. 69, "Shifting the Print-start Position Forward or Backward"
- Set the print-start position near the center of the media.
 - ☞ P. 69, "Shifting the Printing Position to the Left"

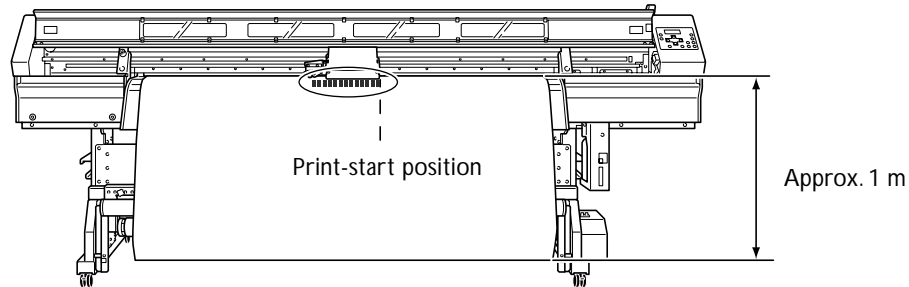









Note, however, that you can also make this setting on the computer (by, for example, choosing the media type in the software RIP you are using). When you have made the setting on the computer, the computer's setting is used and the printer's setting is ignored.

Default Setting

[SETTING]: 0.00%

Changing the Feed-correction Value During Printing

Procedure

- 1  While printing is in progress, press .
- 2  Press .
The current correction value is displayed.
- 3  Use   to set the correction value.
Press  to enable the setting.
The changed correction value is saved and immediately applied to printing.

Description

If white or dark-colored stripes appear during printing, you can change the feed-correction value without stopping the printing operation in progress. If white horizontal stripes appear, you make the correction value smaller. If dark horizontal stripes appear, you make the value larger. You can change the correction value regardless of whether settings made on the machine or settings made on the computer take precedence. A correction value set while printing is in progress is saved only as a setting on the machine.

5-6 Changing the Ink-drying Method

Switching Off the Preheater, Print Heater, or Dryer

Procedure

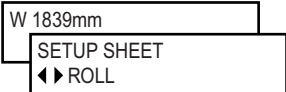
-  Press **HEATER CONFIG** twice.
Use **LEFT** and **RIGHT** to select the device.
Press **DOWN** several times to select "OFF."
Press **ENTER** to enable the setting.
-  Press **MENU**.
Press **LEFT** to go back to the original screen.

Description

This makes the temperature settings for the media heating system (preheater, print heater, and dryer), as well as switching these devices on or off. When this is set to "OFF," these devices do not operate at all.



You can also make these settings on the computer. When you've made the settings on the computer, the computer's settings take precedence and the printer's settings are ignored.

Default Setting

[PRE] (preheater): 35°C (94°F)
[PRINT] (print heater): 35°C (94°F)
[DRYER]: 50°C (122°F)

Determining How the Media Heating System Operates

Procedure

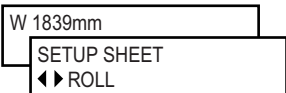
-  Hold down **MENU** and press **HEATER CONFIG**.
-  Press **DOWN**.
-  Press **RIGHT**.
Use **UP** and **DOWN** to make the setting.
Press **ENTER** to enable the setting.
-  Press **MENU**.
Press **LEFT** to go back to the original screen.

Description

This feature controls the temperature of the media heating system automatically when **SET UP** is dark. "MENU" performs heating to the preset temperature at all times, without lowering the temperature when **SET UP** is dark.

"30°C" lowers the media heating system to a fixed temperature (30°C) when **SET UP** is dark.



"OFF" switches off the media heating system when **SET UP** is dark.

Default Setting

[PREHEATING]: 30°C

Drying the Trailing Edge of the Printing Area on the Dryer

Procedure

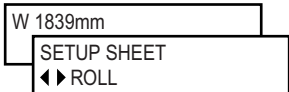
- 1  Hold down **MENU** and press **HEATER CONFIG**.
- 2  Press **RIGHT**.
Use **UP** and **DOWN** to select "ENABLE."
Press **ENTER** to enable the setting.
- 3  Press **MENU**.
Press **LEFT** to go back to the original screen.

Description

When this menu item is set to "ENABLE," additional media feed is performed until the trailing edge of the printing area is positioned directly on the dryer. The margin between the print-end position and the next print-start position is fixed at 200 mm. Any margin setting made on the computer is ignored.

When this is set to "DISABLE," media feed stops simultaneously when printing ends. This means that the trailing edge of the printing area is not fed to the dryer unless you continue with a subsequent printing operation.

When you're using the take-up unit, be sure to set this to "DISABLE."

☞ P. 44, "Operating Conditions for the Take-up System"

Default Setting



[FEED FOR DRY]: DISABLE

5-7 Setting How the Auxiliary Drying Unit Operates

When the optionally available auxiliary drying unit is installed, use the setting menus on the machine to set how the drying unit operates. For detailed information about the auxiliary drying unit, refer to the user's manual for drying unit.

Switching the Drying-heater Unit On and Off

Procedure

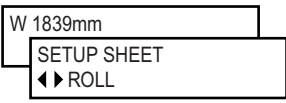
-  Hold down **MENU** and press **HEATER CONFIG**.
Press **▼** twice.
-  Press **▶**.
Use **▲** **▼** to select "ENABLE" or "DISABLE."
Press **ENTER**.
-  Press **MENU**.
Press **◀** to go back to the original screen.

Description

This switches the auxiliary drying unit's drying-heater unit on or off. The temperature setting for the drying-heater unit is based on the setting made on the machine. After you've completed installation of the auxiliary drying unit, set the machine's [OPTION DRYER] menu item to "ENABLE."

Default Setting

[OPTION DRYER]: DISABLE

Switching the Blower-fan Unit On and Off

Procedure

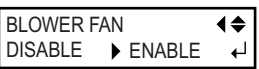
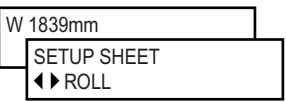
-  Hold down **MENU** and press **HEATER CONFIG**.
Press **▲**.
-  Press **▶**.
Use **▲** **▼** to select "ENABLE" or "DISABLE."
Press **ENTER**.
-  Press **MENU**.
Press **◀** to go back to the original screen.

Description

This switches the auxiliary drying unit's blower-fan unit on or off. After you've completed installation of the auxiliary drying unit, set the machine's [BLOWER FAN] menu item to "ENABLE."



Default Setting

[BLOWER FAN]: DISABLE

5-8 Saving the Printer Settings to Match the Media

Saving Optimized Media Settings As Preset Values

Procedure

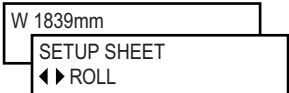
-  Press **MENU**.
-  Press **▶**.
Press **▼**.
-  Press **▶**.
Use **▲** **▼** to select any one from "NAME1" to "NAME8."
Press **ENTER** to save.
The present menu settings are saved in the preset you chose in step **3**.
-  Press **MENU**.
Press **◀** to go back to the original screen.

Description

Using the [PRESET] menu item lets you easily change a wide variety of settings to optimize them for the media. Making changes for each menu item every time you change the media can be troublesome. That's why it can be useful to save the menu-item settings optimized for an often-used type of media as a preset. The next time you use the media, you can change the menu-item settings to the optimal values for the media simply by loading the preset you saved. Menu items that can be saved in presets are listed below.









Menu item	Page to see
[ADJUST BI-DIR SIMPLE SETTING]	P. 82, "Correcting for Misalignment in Bidirectional Printing"
[ADJUST BI-DIR DETAIL SETTING]	P. 83, "Correcting for Misalignment in Bidirectional Printing More Precisely"
[ALTERNATE HEAD]	P. 78, "Giving Priority Efficient Ink Use During Operation"
[BLOWER FAN]	P. 89, "Switching the Blower-fan Unit On and Off"
[CALIBRATION]	P. 85, "Performing Feed Correction to Alleviate Horizontal Bands and the Like"
[FEED FOR DRY]	P. 88, "Drying the Trailing Edge of the Printing Area on the Dryer"
[FULL WIDTH S]	P. 74, "Speeding Up Printing for Narrow Media"
[MEDIA RELEASE]	P. 75, "Using Sticky Media"
[PRE], [PRINT], [DRYER]	P. 34, "Making the Temperature Setting for the Media Heating System"
[PREHEATING]	P. 87, "Determining How the Media Heating System Operates"
[SCAN INTERVAL]	P. 73, "Printing Hard-to-dry Media"
[SHEET TYPE], [SHEET WIDTH], [SHEET POS.]	P. 71, "Using Transparent Media"
[SIDE MARGIN]	P. 70, "Expanding the Printing Area by Reducing the Margins"
[VACUUM POWER]	P. 73, "Preventing Media from Coming Loose"

You can save up to eight presets. You can assign a name to each preset. Using media names may aid recognition and clarity.

☞ P. 91, "Loading a Saved Preset," p. 91, "Assigning a Name to a Preset"



Loading a Saved Preset

Procedure

- 1  Press .
- 2  Press  twice.
Use   to select the name of a preset you want to load.
- 3  Press  to load.
The settings are changed and the screen shown in the figure appears.











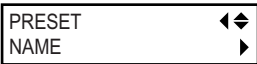



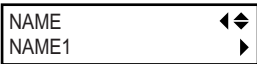



Description

This loads a saved preset. You can select any one of eight types of presets. (When no names have been assigned, you select from among NAME1 through NAME8.)

If you load a preset while  is illuminated,  goes dark. To start printing, press  once more and redo the preparations for printing.

Assigning a Name to a Preset

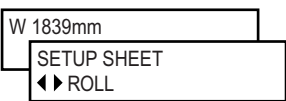
Procedure

- 1  Press .
Press .
Press  twice.
- 2  Press .
Use   to select any one from NAME1 to NAME8.
- 3  Press .
Use   to enter a character.
- 4  Press .
Use   to enter the next character.
Enter the following characters in the same way.
When you're finished entering text, press .
- 5  Press .
Press  to go back to the original screen.

Description











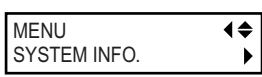

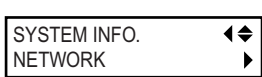



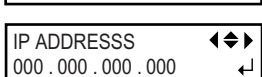

This assigns a name to a saved preset. Using media names may aid recognition and clarity.

The characters you can enter are "A" through "Z," "0" through "9," and the "-" character. You can enter up to 15 characters, including spaces.

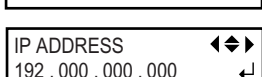
5-9 Making the Network Settings

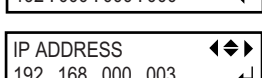
Setting the IP Address, Subnet Mask, Etc.

Procedure

- 1**  Press  .
Press  several times.
- 2**  Press  .
Press  .
- 3**  Press  .
Use   to choose the item whose setting you want to make.
- 4**  Press  twice.
Use   to select the address number.
- 5**  Press  .
- 6**  Repeat **4** and **5** to set all the address numbers.
When you have finished making the setting, press  .
- 7**  Press  .
Press  to go back to the original screen.

Description

Make sure the machine is connected to the network by an Ethernet cable.
For detailed information about the settings, consult your network administrator.

[IP ADDRESS]: IP address













[SUBNET MASK]: Subnet mask

[GATEWAY ADDR.]: Gateway address

5-10 Viewing Information about the Media and the System

Displaying the Amount of Media Remaining

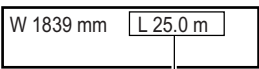
Procedure

-  Press .
Press .
-  Press .
Press .
-  Press .
Use   to set the amount of media remaining.
Press  to enable the setting.
-  Press .
Press  to go back to the original screen.

This display is updated.

If setup has not been performed, the set value flashes.

Description

You can display how much of the media in use is left. Once you set the amount of media remaining, the amount remaining is displayed at the top menu until it reaches zero. If you cancel the setup such as by removing the media, the amount remaining at that time flashes on the screen.













The amount of media remaining is not updated automatically when you change the media. Redo the setting whenever you change the media.

You can also make the setting display this menu item automatically whenever you change the media. See the next section, "Verifying the Setting for the Amount Remaining Every Time the Media Is Changed."

Note: The remaining amount that is displayed is only an estimate, and its accuracy is not assured.

Verifying the Setting for the Amount Remaining Every Time the Media Is Changed

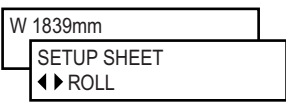
Procedure

-  Press .
Press .
-  Press .
Press  twice.
-  Press .
Use   to select "ENABLE."
Press  to enable the setting.
-  Press .
Press  to go back to the original screen.

Description

Setting this to "ENABLE" automatically displays the [SHEET REMAIN] menu item whenever you change the media and finish setup. This makes it impossible to go on to the next operation unless you redo the setting for the amount remaining. This can be useful for keeping you from forgetting to redo the setting when you change the media.

When you set this to "ENABLE," however, be sure also to set the [SHEET TYPE] menu item to "OPAQUE." When the [SHEET TYPE] menu item is set to "CLEAR," then the [SHEET REMAIN] menu item is not displayed automatically, regardless of the setting for the [AUTO DISPLAY] menu item.







☞ P. 71, "Using Transparent Media"

Default Setting

[AUTO DISPLAY]: DISABLE

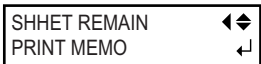
Printing the Amount of Remaining Media

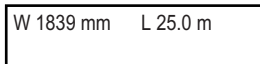
Procedure







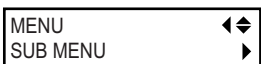

- 1  Press  .
Press  .
- 2  Press  .
Press  to perform printing.
- 3  Press  .
Press  to go back to the original screen.

Description

This prints the amount of media remaining that is displayed at the top menu. You use this when you want to make a record of the remaining length of the media now in use. Printing the amount of media remaining before you change the media enables you to refer to the printed record and use the value to make the setting for the remaining amount the next time you use the media.

Printing a System Report

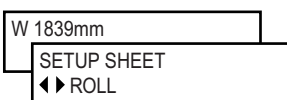
Procedure









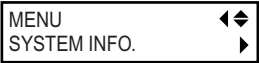

- 1  Press  .
Press  several times.
- 2  Press  .
Press  several times.
Press  to start printing.
- 3  Press  .
Press  to go back to the original screen.

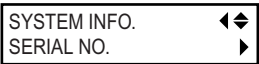
Description

This prints system information, including a list of setting values.

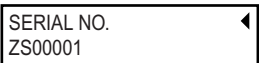
Viewing the Serial Number, Firmware Version, and Other Information

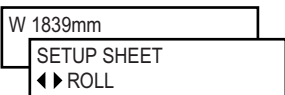
Procedure

- 1  Press .
Press  several times.
- 2  Press .
Use   to choose the information you want to view.
- 3  Press .
- 4  Press .
Press  to go back to the original screen.

Description

You can view the following information.

[MODEL]: Model name











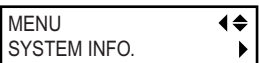

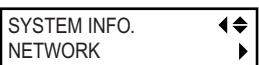
[SERIAL NO.]: Serial number

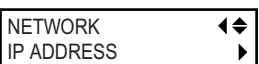
[INK]: Ink type

[FIRMWARE]: Firmware version

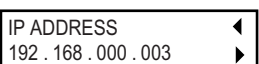
Viewing the Network Settings

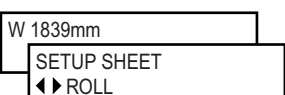
Procedure

- 1  Press .
Press  several times.
- 2  Press .
Press .
- 3  Press .
Use   to choose the information you want to view.
- 4  Press .
- 5  Press .
Press  to go back to the original screen.

Description

You can view the following information.

[IP ADDRESS]: IP address

[SUBNET MASK]: Subnet mask

[GATEWAY ADDR.]: Gateway address



[MAC ADDRESS]: MAC address



5-11 Performing Maintenance



Draining Ink and Performing Internal Washing

Procedure

- | | |
|----------|----|
| MENU | ◀◆ |
| SUB MENU | ▶ |

 Press  .
Press  several times.
- | | |
|-------------|----|
| SUB MENU | ◀◆ |
| INK CONTROL | ▶ |

 Press  .
Press  twice.
- | | |
|-------------|----|
| INK CONTROL | ◀◆ |
| HEAD WASH | ▶↵ |

 Press  .
Press  twice.
Press  to execute.

Description



This drains the ink inside the printer and washes the interior using cleaning cartridges as a preliminary for moving the printer or conducting maintenance. This operation requires eight unused cleaning cartridges. The screen displays information such as instructions to insert and remove cartridges. Follow these instructions to carry out the procedure. After finishing washing, the sub power is switched off.



You do not need to carry this out as part of your daily maintenance activities.



Draining Ink Remaining Inside the Machine

Procedure

- | | |
|----------|----|
| MENU | ◀◆ |
| SUB MENU | ▶ |

 Press  .
Press  several times.
- | | |
|-------------|----|
| SUB MENU | ◀◆ |
| INK CONTROL | ▶ |

 Press  .
Press  twice.
- | | |
|-------------|----|
| INK CONTROL | ◀◆ |
| PUMP UP | ▶↵ |

 Press  .
Press  .
Press  to execute.

Description

This removes ink inside the printer as a preliminary procedure for performing maintenance. The screen displays information such as instructions to insert and remove cartridges. Follow these instructions to carry out the procedure. After finishing the procedure, the sub power is switched off.

You do not need to carry this out as part of your daily maintenance activities.

5-12 Menu List

Main Menu

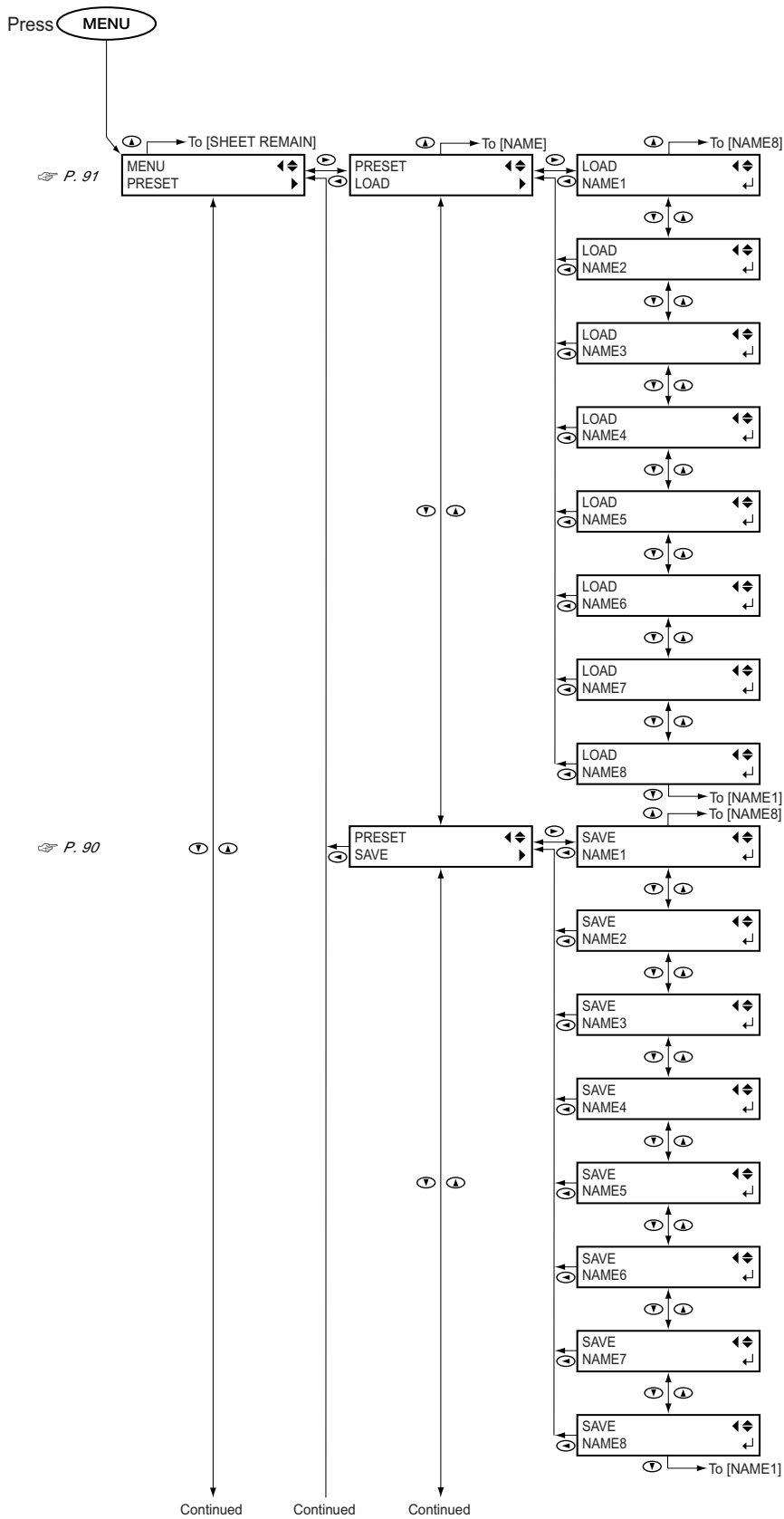

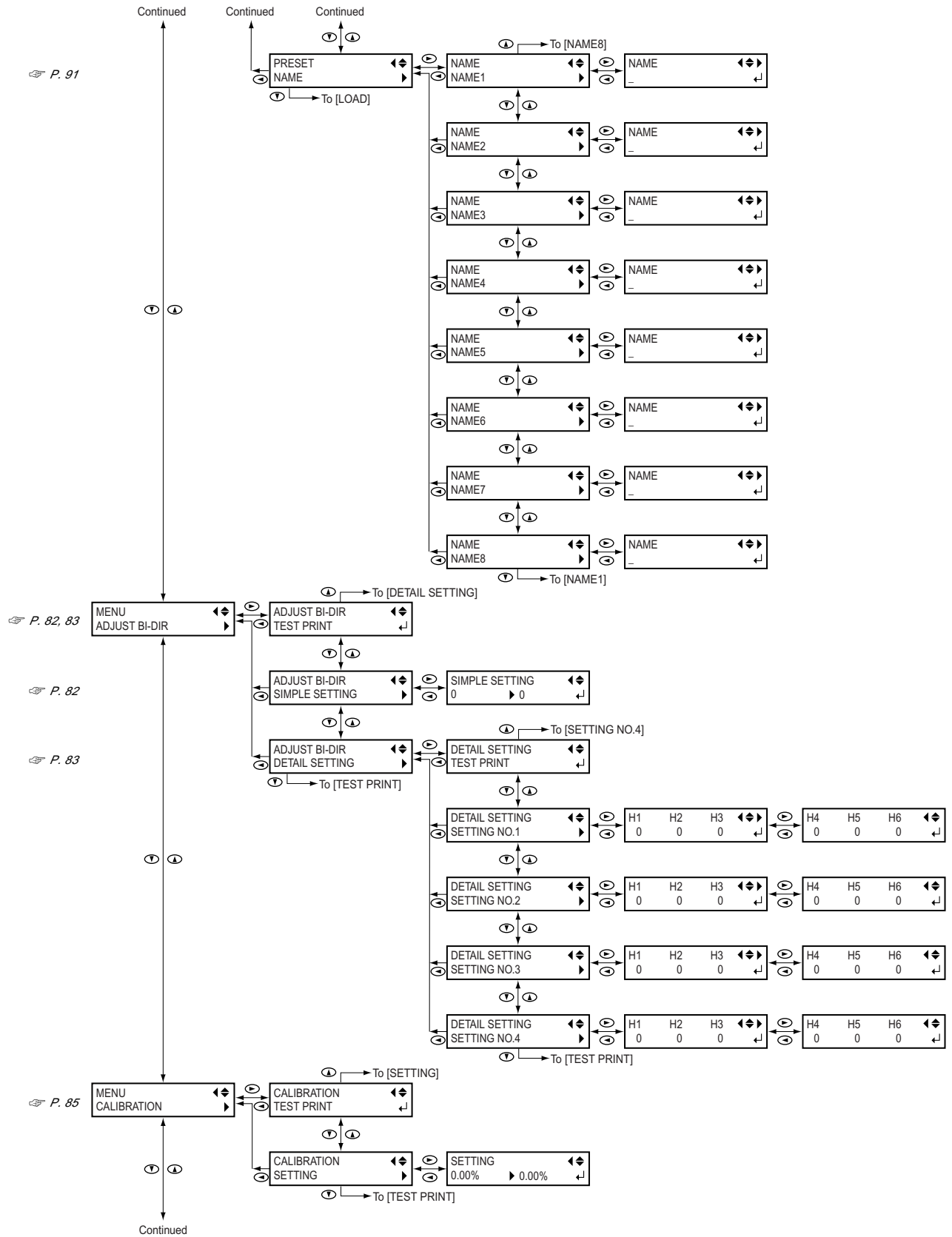

5-12 Menu List

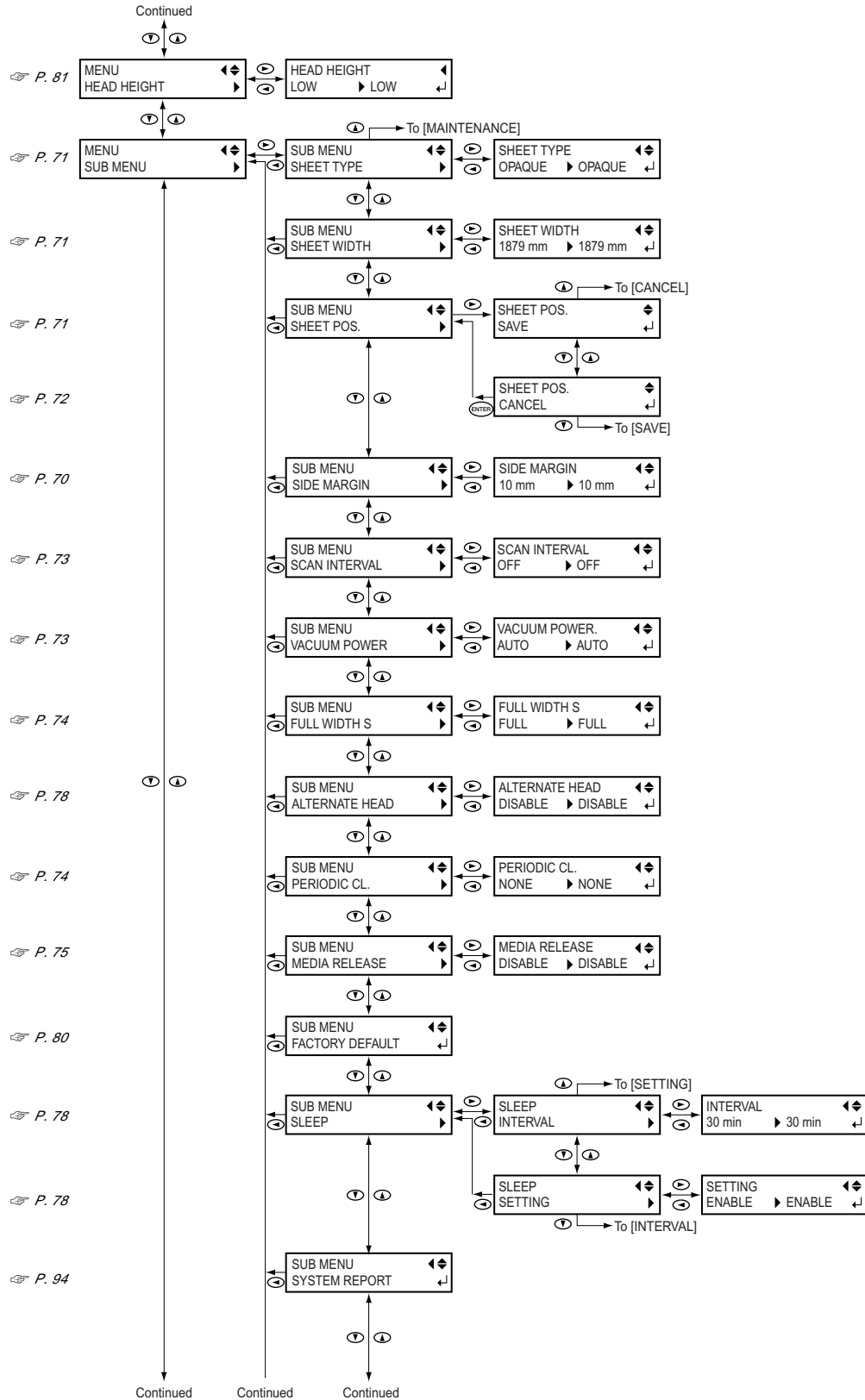

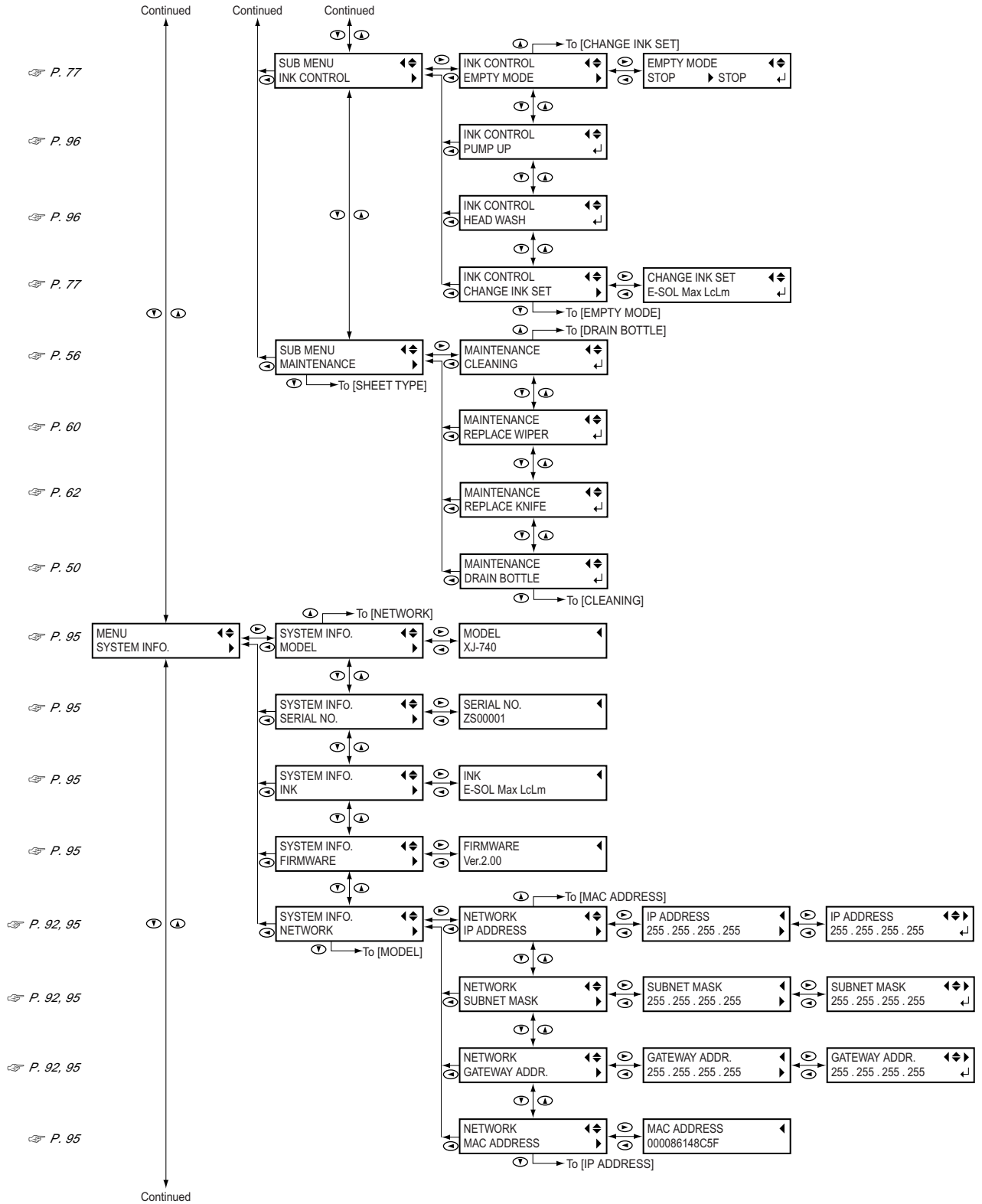

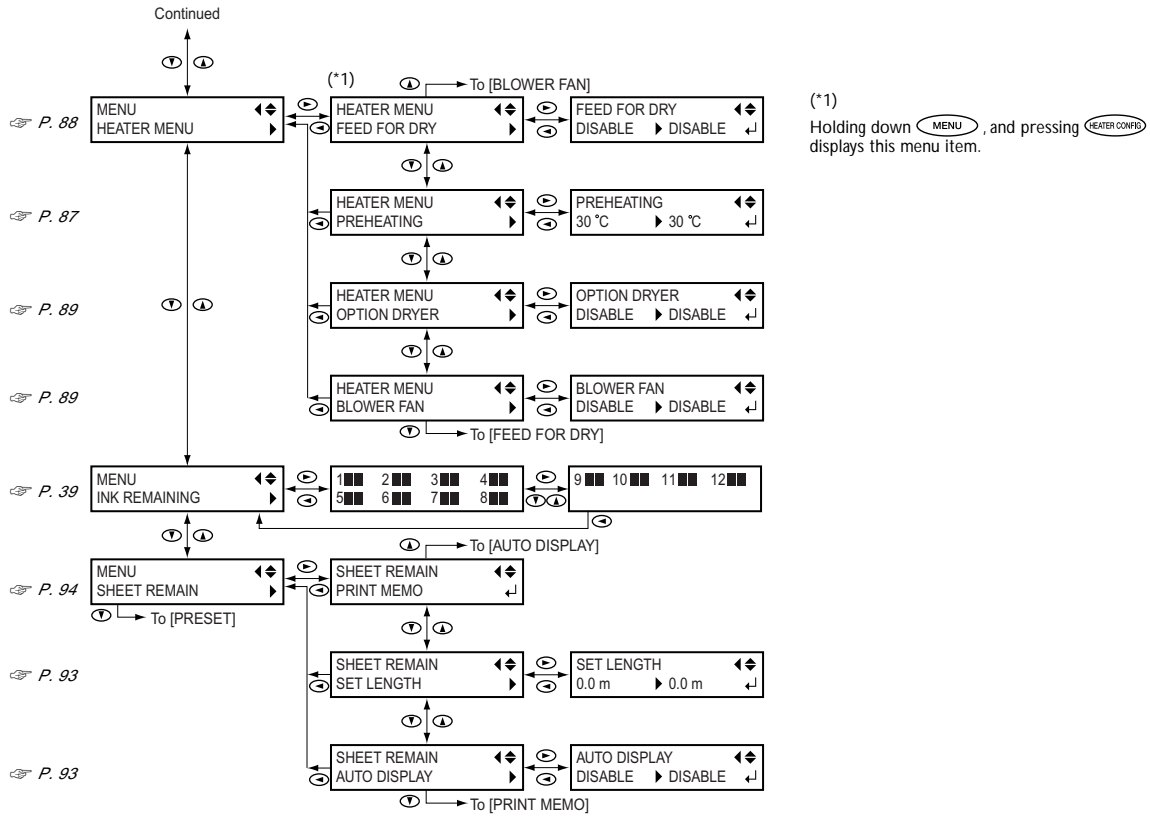

Language and Unit Menu

Hold down **MENU** and switch on the sub power.

P. 79

MENU LANGUAGE
ENGLISH

P. 79

LENGTH UNIT
mm

P. 79

TEMP. UNIT
°C

Cleaning Menu

Press **CLEANING**.

P. 38

CLEANING NORMAL CL. NORMAL CL. ABC

P. 54

CLEANING MEDIUM CL. MEDIUM CL. ABC

P. 54

CLEANING POWERFUL CL. POWERFUL CL. ABC

Hold down **CLEANING** for one second or longer.

Head cleaning for all groups
P. 38, "When you want to clean all heads simultaneously"

Heater Configuration Menu

Press **HEATER CONFIG.**

P. 34

PRE 35 PRINT 35
DRYER 50

P. 34

PRE 35 PRINT 35 DRYER 50
35 ▶ 35 ↓ 35 ▶ 35 ↓ 50 ▶ 50 ↓

Chapter 6

What to Do If

6-1 The Machine Doesn't Run

The Printer Unit Doesn't Run

Is the power switched on?

Switch on the printer's main power, then press the sub power switch and make sure the sub power switch lights up.

Is **SET UP** illuminated?

Printing is not performed when **SET UP** is not illuminated. Pull back the loading lever, close the front cover, and press **SET UP**.

Is the front cover open?

Close the front cover.

Is the top menu displayed?

If the top menu isn't displayed, printing doesn't start even when data is sent from the computer. To go to the top menu, press **MENU**, then press **◀**.

☞ P. 36, "Getting Ready to Receive Data from a Computer"

Is **PAUSE** illuminated?

When **PAUSE** lights up, operation is paused. To resume, press **PAUSE**. **PAUSE** goes dark and printing resumes.

Has ink run out?



When printing data is sent while the screen shown in the figure is displayed, a message appears and a warning beep sounds. At the same time, operation pauses. When the ink cartridge is replaced with a new one, printing starts.

☞ P. 39 "If Ink Runs Out"

☞ P. 77, "Determining What Happens When an Ink Cartridge Is Empty"

Is a message displayed on the screen?

☞ P. 113, "If a Message Appears"

☞ P. 114, "If an Error Message Appears"

Is the power cord connected?

Connect the power cord securely.

Is the Link LED lighted?

If the Link LED for the Ethernet connector is not lighted, it means that a correct connection to the network has not been made. Make sure the network routing is suitable. Try connecting the computer and the machine to the same hub, or connecting them directly using a crossover cable. If this makes it possible to perform printing, it means the problem is in the network itself.

Are the network settings correct?

If printing is not possible even though the Link LED is lighted, check to make sure the IP address and other such settings are correct. The settings on both the machine and the computer must be appropriate. Redo the settings, checking to ensure that the IP address doesn't conflict with the IP address for another device on the network, that the port set-

ting for the software RIP specifies the IP address set on the machine, that the settings have no typing errors, and for other such problems.

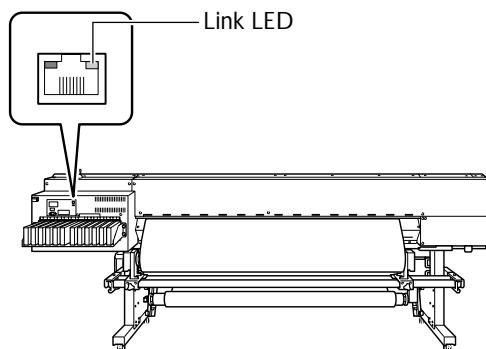

☞ Setup Guide

☞ P. 92, "Setting the IP Address, Subnet Mask, Etc."

Did the software RIP end abnormally?

Make sure the software RIP is running correctly, then switch the sub power switch off and back on.

The Media Take-up System Doesn't Run

Is the take-up unit cable connected?

Connect the take-up unit cable to the machine. To perform take-up automatically during printing, also make the setting for the AUTO switch.

☞ Setup Guide

☞ P. 45, "Loading Roll Media"

The Media Heating System Doesn't Warm Up

Is media loaded?

The media heating system does not warm up to the preset temperature when **SET UP** is dark (by default). Load media, press **SET UP**, and wait for the machine to warm up.

☞ P. 87, "Determining How the Media Heating System Operates"

Is the temperature of the room too low?

Use the machine in an environment where the temperature is 20 to 32°C (68 to 90°F).

6-2 Attractive Printing Is Impossible

Printed Results Are Coarse or Contain Horizontal Stripes

Do the print heads show dot drop-out?

Carry out a printing test and make sure no dot drop-out occurs. If dot drop-out is present, perform head cleaning.

☞ P. 37, "Printing Tests and Cleaning"

☞ P. 54, "When Head Cleaning Is Not Effective"

Is the head height appropriate?

Printing when the [HEAD HEIGHT] menu item is set to "HIGH" is coarser than when set to "LOW." Keep this set to "LOW" except when changing it is necessary, such as when you're using thick media.

☞ P. 81, "Adjusting Head Height to Match Media Thickness"

Have you carried out feed correction?

Large misalignment in the amount of feed of the media may result in printing that seems coarse or contains horizontal stripes. Either make the setting on the computer to match the type of media you're using, or make the setting for correction on the printer.

☞ P. 85, "Performing Feed Correction to Alleviate Horizontal Bands and the Like"

Did the media become slack during feed correction?

Slackness of the media during feed correction makes accurate correction impossible. Carry out feed correction with the media pulled taut.

☞ P. 85, "Performing Feed Correction to Alleviate Horizontal Bands and the Like"

After feed correction, was the media pulled back?

Never pull the media back after carrying out feed correction. Doing so may cause the correction results not to be applied properly and result in horizontal stripes.

☞ P. 85, "Performing Feed Correction to Alleviate Horizontal Bands and the Like"

Have you carried out bidirectional correction?

When you are performing bidirectional printing, use the [ADJUST BI-DIR] menu item to carry out correction. The optimal adjustment value may vary, depending mainly on the thickness of the media. Set or select an adjustment value that is suited to the media.

☞ P. 82, "Correcting for Misalignment in Bidirectional Printing"

☞ P. 83, "Correcting for Misalignment in Bidirectional Printing More Precisely"

Is the media heating system at a suitable temperature?

If the ink forms lumps or smudges, raise the temperature. Note, however, that a temperature that is too high may degrade the media or cause it to wrinkle.

☞ P. 34, "Settings for the Media Heating System"

Is the temperature of the room too low?

The media heating system may not warm up sufficiently when the ambient temperature is less than 20°C (68°F). Also, even when the media heating system reaches its preset temperatures, adequate effectiveness may not be apparent if the media is thoroughly chilled. Before printing, allow the

media to come to room temperature.

Is the print mode suitable?

If attractive printing is impossible even when the media heating system is at a high temperature, try using a higher-quality print mode.

Depending on the media, smudging may occur when using a high-quality print mode, and results may also vary greatly depending on the settings of your software RIP (such as the color-profile selection). Make settings suited to the media you're using.

Is the printer installed in a level and stable location?

Never install the machine in a location where it is tilted or where it may wobble or experience vibration. Also make sure that the print heads are not exposed to moving air. These factors may lead to missing dots or reduced printing quality.

Is the media loaded and set up correctly?

If the media is not loaded and set up correctly, media feed may not be smooth, or printing may be adversely affected.

☞ P. 111, "Media Wrinkles or Shrinks, or Feed Is Unstable"

Are the settings for the [PRESET] menu item appropriate?

If the settings selected with the [PRESET] menu item are not suitable for the type of media, printing may be adversely affected. Choose settings optimized to the media you're using.

☞ P. 90, "Saving Optimized Media Settings As Preset Values"

☞ P. 91, "Loading a Saved Preset"

Colors Are Unstable or Uneven

Did you shake the ink cartridges gently before installing them?

Before you install a new ink cartridge, gently shake the cartridge.

Is the media wrinkled?

If the media is wrinkled and comes loose from the platen, colors may be uneven or printing quality may suffer.

☞ P. 111, "Media Wrinkles or Shrinks, or Feed Is Unstable"

Is the media sagging?

Performing printing using sagging roll media makes uneven colors more likely.

Was printing paused partway through?

When printing is paused, the coloring at the seam may be altered when printing resumes. Avoid pausing printing. With the factory-default settings, printing pauses when an ink cartridge runs empty. Before you perform lengthy printing, check the amount of ink remaining in the ink cartridges. Printing may also pause when data is not sent from the com-

puter quickly enough.

Are the operating parameters set to appropriate values?

Depending on the settings for such menu items as [FULL WIDTH S] and [PERIODIC CL.], uneven colors may occur. If the settings have been changed, try restoring them to their default values.

☞ P. 74, "Speeding Up Printing for Narrow Media"

☞ P. 74, "Preventing Soiling of the Media and Dot Drop-out During Printing"

Is the printer installed in a level and stable location?

Never install the machine in a location where it is tilted or where it may wobble or experience vibration. Also, ensure that the print heads are not exposed to wind or blown air. These factors may lead to missing dots or reduced printing quality.

Is the printer being used in a location subject to severe changes in the operating environment?

Large fluctuations in temperature or humidity while printing is in progress may cause the colors to change partway through. When you're performing printing, use the machine in a location where temperature and humidity are stable.

Are the settings for the [PRESET] menu item appropriate?

If the settings selected with the [PRESET] menu item are not suitable for the type of media, printing may be adversely affected. Choose settings optimized to the media you're using.

☞ P. 90, "Saving Optimized Media Settings As Preset Values"

☞ P. 91, "Loading a Saved Preset"

The Media Becomes Soiled When Printed

Do the print heads contact the media?

The height of the print heads may be too low. Also, if the media is not loaded and set up correctly, it may wrinkle or come loose and strike the heads.

☞ P. 81, "Adjusting Head Height to Match Media Thickness"

☞ P. 111, "Media Wrinkles or Shrinks, or Feed Is Unstable"

Are the print heads dirty?

The following may cause ink to drip on the media during printing.

- Buildup of fibrous dust (lint) around the heads.
- Ink transferred to the heads due to rubbing against the media.

If this happens, clean the heads using the cleaning kit. We recommend carrying out periodic head cleaning.

☞ P. 56, "Cleaning the Heads Using the Cleaning Kit"

Are the pinch rollers dirty?

Periodically clean the pinch rollers.

☞ P. 52, "Cleaning"

6-3 The Media Jams

The Media Jams

If an error message is displayed because the media has jammed, immediately correct the problem. Failure to do so may damage the print heads.

☞ P. 114, [MOTOR ERROR TURN POWER OFF]

Is the media warped or wrinkled?

Many factors can cause warping or wrinkling. Refer to the following and correct the problem.

☞ P. 111, "Media Wrinkles or Shrinks, or Feed Is Unstable"

Is the height of the print heads too low?

Try raising the heads higher. Media may inevitably warp or wrinkle slightly, so adjust the height of the heads to take this into account.

☞ P. 81, "Adjusting Head Height to Match Media Thickness"

6-4 The Media Cannot Be Taken Up Smoothly

The Media Cannot Be Taken Up Smoothly

Is media feed unstable?

Various factors can make media feed unstable. Refer to the following and correct the problem.

☞ P. 111, "Media Wrinkles or Shrinks, or Feed Is Unstable"

Is the paper tube installed correctly?

Securely insert the paper tube onto the end caps. If the paper tube is not attached correctly, it may spin without traction and fail to take up the media.

☞ Setup Guide

Is the paper tube bent or sagging?

Media cannot be taken up smoothly when the paper tube is bent or sagging.

6-5 Media Wrinkles or Shrinks, or Feed Is Unstable

A variety of problems can occur if the media feed is not smooth. This can cause such problems as poor printing quality, contact with the media by the print heads, misaligned positioning, media jams, or poor take-up. Take action as follows.

Media Wrinkles or Shrinks

Is the media loaded and set up straight and securely?

Feed is not smooth when the media is not straight or is tensioned unevenly on the left and right. Reload the media.

Was loaded media allowed to stand for some time?

Media may shrink or wrinkle if it is heated for an extended time. When printing ends, switch off the sub power or remove the media.

Are the media clamps mounted?

When you're performing printing, be sure to attach the media clamps.

Was the media loaded while the apron and platen were at high temperatures?

Loading media while the apron and platen are heated may cause shrinkage or wrinkling during printing due to sudden warming. Before loading media, switch off the sub power and allow the apron and platen to cool.

Is the temperature of the media heating system too high?

Set the temperature to suitable values for the type of media.

☞ P. 34, "Settings for the Media Heating System"

Media Feed Is Not Straight

Is the media loaded and set up straight and securely?

Feed is not smooth when the media is not straight or is tensioned unevenly on the left and right. Reload the media.

Are the media holders securely fastened in place?

If the retaining screws for the media holders are not tightened securely, the roll may become unstable, impeding smooth media feed. Firmly tighten the retaining screws so that the media holders do not move.

Media Feed Is Not Smooth

Does the media strike some other object?

Make sure the media does not touch anything else. This may affect printing, even when feed appears to be smooth.

Was loaded media allowed to stand for some time?

Media may stick to the platen if it is heated for an extended time. When printing ends, switch off the sub power or remove the media.

Is the media too thick?

Media that is too thick may not only cause unstable feed, but may scrape the print heads, resulting in malfunction. Never use such media.

Are the grit rollers dirty?

Check to make sure the grit rollers are free of buildup of foreign material such as media scraps.

6-6 The Print Heads Stopped Moving

If the print-head carriage stops over the platen, take action immediately to prevent the heads from drying out.

What to Do First

Switch the sub power off, then back on again. (If the media is jammed, then also remove the media.) If the print-head carriage move to the standby position (the right side of the main unit), it means the operation has ended successfully. If the print-head carriage did not move, try switching off the main power, then again switching on the main power, followed by the sub power.

If the Heads Still Do Not Move

If the heads still do not move, carry out the following emergency response measure, then contact your authorized Roland DG Corp. dealer.

1. Switch off the main power.
2. Open the front cover.
3. Gently move the print-head carriage by hand as far as the standby position.

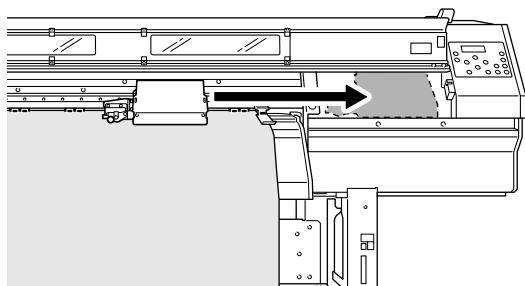

4. Insert the cap-unit tool into the hole at the bottom of the machine and turn gently. The cap unit rises.

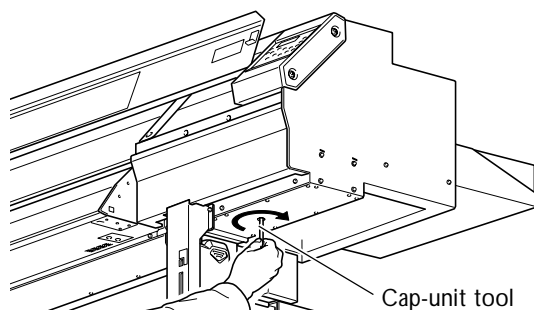

5. Make the guides at the edges of the print heads line up with the guides at the edges of the cap unit. Turn the tool further to bring the cap unit near the heads.

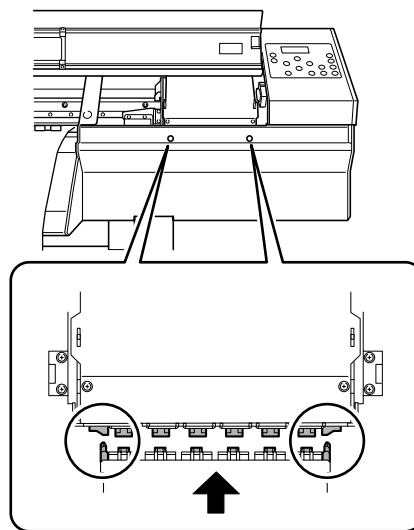

6. When the heads make contact with the cap unit, turn the tool one or two turns more.

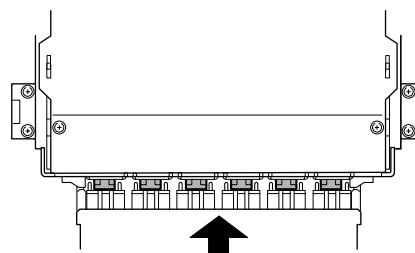

Make sure the print heads are capped tightly.

6-7 If a Message Appears

These are the main messages that appear on the machine's display to prompt correct operation. They do not indicate any error. Follow the prompts and take action accordingly.

[1 ■ 2 ■ 3 ■ 4 ■ ...]

Only a small amount of ink remains. Replace the cartridge indicated by the flashing number with a new cartridge.

[CHECK DRAIN BOTTLE]

This appears when a certain amount of discharged fluid collects in the drain bottle. To clear the message, press **ENTER**. If this screen appears, go to the [DRAIN BOTTLE] menu item and discard the discharged fluid in the bottle.

☞ P. 50, "Disposing of Discharged Ink"

[CLOSE THE FRONT COVER]

Close the front cover. For safety, the carriage does not operate while a cover is open.

[END OF THE SHEET]

The trailing edge of the media was detected during operation. Press any key on the operation panel to clear the message. Load new media.

[INSTALL DRAIN BOTTLE]

Check whether the drain bottle is installed. Install the drain bottle, then press **ENTER**.

[NOW HEATING...]

Wait until the media heating system reach the preset temperature. Printing starts when **HEATER CONFIG** lights up.

You can stop printing by holding down **SET UP** for one second or longer while this is displayed. Pressing **PAUSE** makes printing start immediately, without waiting to reach the preset temperature.

[PRESS POWER KEY TO CLEAN]

This appears when the machine has been unused for about one month. Switch on the sub power once a month.

☞ P. 64, "When Not in Use for a Prolonged Period"

[REMOVE MEDIA CLAMPS]

This appears when media cutoff is attempted without first removing the media clamps. Execute media cutoff only after first detaching the media clamps. Pressing **◀** while this message is displayed quits cutoff.

[REMOVE SOLCL-LIQUID]

Remove the cleaning cartridge indicated by the flashing number. This message appears at times such as during head cleaning.

[REMOVE SOL CRT.]

Remove the ink cartridge indicated by the flashing number. This message appears at times such as during cartridge replacement.

[SET CARTRIDGE.]

Insert the ink cartridge indicated by the flashing number. This message appears at times such as during cartridge replacement.

[SET SOLCL-LIQUID]

Insert the cleaning cartridge indicated by the flashing number. This message appears at times such as during head cleaning.

[SET SOL CRT.]

Insert the ink cartridge indicated by the flashing number. This message appears at times such as during cartridge replacement.

[SET HEAD HEIGHT TO xxx]

The height of the print heads is lower than the height specified on the computer.

The heads move to a location where you can operate the height-adjustment lever. Adjust to the displayed height, then press **ENTER**.

[SHEET NOT LOADED PRESS SETUP KEY]

Load media and press **SET UP**. This message appears when an attempt to perform a printing test was made while no media was loaded.

[TIME FOR MAINTENANCE]

It is time to clean the heads using the cleaning kit. After verifying, press **ENTER**.

☞ P. 56, "Cleaning the Heads Using the Cleaning Kit"

[TIME FOR WIPER REPLACE]

It is time to replace the wipers. After verifying, press **ENTER**.

☞ P. 60, "Replacing the Wipers"

6-8 If an Error Message Appears

This describes the error messages that may appear on the machine's display, and how to take action to remedy the problem. If the action described here does not correct the problem, or if an error message not described here appears, contact your authorized Roland DG Corp. dealer.

[AVOIDING DRY-UP TURN OFF POWER]

The print heads were forced to standby position to prevent them from drying out.

Operation cannot be continued. Switch the sub power off, then back on. Opening the front cover while printing is in progress causes an emergency stop. Never allow the print heads to remain in this state.

[DATA ERROR CANCELING...]

Printing was stopped because a problem was found in the data received.

Operation cannot be continued. Check whether the data contains errors. Also, check for a problem with the connector cable or the computer, and redo the operation from the step of loading the media.

[HEAD HEIGHT ERROR]

The height-adjustment lever for the print heads was operated improperly.

Operation cannot be continued. Switch the sub power off, then back on. To change the head height, use the [HEAD HEIGHT] menu item.

☞ P. 81, "Adjusting Head Height to Match Media Thickness"

[HEATING TIMEOUT CONTINUE?]

The media heating system did not reach the preset temperature.

This occurs because the temperature of the location where the machine is installed is too low. We recommend raising the temperature. To quit printing, hold down **SET UP** for one second or longer. To continue waiting for the temperature of the media heating system to rise, press **ENTER**. To start printing immediately, press **PAUSE**.

[MOTOR ERROR TURN POWER OFF]

A motor error occurred.

Operation cannot be continued. Switch off the sub power. Next, eliminate the cause of the error, then immediately switch on the sub power. If the machine is allowed to stand with the error uncorrected, the print heads may dry out and become damaged.

This error may be caused by such factors as a mistake in loading the media, a media jam, or an operation that pulls the media with excessive force.

The media has jammed.

Carefully remove the jammed media. The print heads may also be damaged. Perform head cleaning, then perform a printing test and check the results.

The media was pulled with excessive force.

Excessive tension was applied to the media, and additional action is necessary to recover from this state. First, move the loading lever to the rear and adjust the media to create a small amount of slack, then switch on the sub power.

[OPTION-DRYER IS NOT CONNECTED]

The optional auxiliary drying unit is not connected.

The [OPTION DRYER] menu item was set to "ENABLE" while the optionally available auxiliary drying unit was not connected. Turn off the sub power and main power switches, then correctly connect the auxiliary drying unit.

[PINCHROLL ERROR LOWER PINCHROLL]

****SET UP** was pressed without first lowering the pinch rollers.**

Press any key to clear the error. Pull back the loading lever, then press **SET UP**.

The pinch rollers were raised while **SET UP was illuminated.**

The error is cleared automatically after a short wait. Never move the loading lever while printing is in progress.

[SERVICE CALL xxxx]

An unrecoverable error occurred, or part replacement that must be performed by a service technician is required.

Note the number displayed, then switch off the sub power. After you switch off the power, inform your authorized Roland DG Corp. dealer of the number that appeared on the display.

[SHEET SET ERROR SET AGAIN]

****SET UP** was pressed even though no media is loaded.**

Press any key to clear the error. Load media and pull back the loading lever, then press **SET UP**.

The [SHEET TYPE] menu item is set to "OPAQUE," but transparent media was loaded.

Press any key to clear the error. Set the [SHEET TYPE] menu item to "CLEAR," then reload the media.

☞ P. 71, "Using Transparent Media"

[TEMPERATURE IS TOO HIGH **°C]

The temperature of the location where the machine is installed has risen above the ambient temperature at which the machine can operate.

Operation cannot be continued. Switch off the sub power. The displayed temperature is the current ambient temperature of the installation location. Bring the installed location to a temperature at which operation is possible (15 to 32°C (59 to 90°F)) and allow the machine to come to room temperature, then turn on the power.

[TEMPERATURE IS TOO LOW **°C]

The temperature of the location where the machine is installed has fallen below the ambient temperature at which the machine can operate.

Operation cannot be continued. Switch off the sub power. The displayed temperature is the current ambient temperature of the installation location. Bring the installed location to a temperature at which operation is possible (15 to 32°C (59 to 90°F)) and allow the machine to come to room temperature, then turn on the power.

[WRONG CARTRIDGE]

A cartridge that cannot be used was installed.

Remove the cartridge to clear the error. Use a cartridge of the specified type.

Chapter 7

Specifications

7-1 Usable Media

Conditions for Usable Media

Media width

XJ-740: 210 to 1,879 mm (8.3 to 74 inches)

XJ-640: 210 to 1,625 mm (8.3 to 64 inches)

XJ-540: 210 to 1,371 mm (8.3 to 54 inches)

Roll outer diameter (A)

Maximum 210 mm (8.3 inches)

Paper tube (core) inner diameter (B)

76.2 mm (3 inches) or 50.8 mm (2 inches)

Note: Using roll media whose paper tube has an inner diameter of 2 inches requires the included media flanges.

Media thickness (C)

Maximum 1.0 mm (39 mil)

Roll weight

XJ-740: 47 kg (103 lb.)

XJ-640: 40 kg (88 lb.)

XJ-540: 30 kg (66 lb.)

Other conditions

Media such as the following cannot be used.

- > Media whose end is attached to the paper tube (core)
- > Media which is severely warped or which has a strong tendency to reroll
- > Media that cannot withstand the heat of the media heating system
- > Media that cannot withstand the tensioning of the media take-up or feed system
- > Media whose paper tube (core) is bent or crushed
- > Media that bends under its own weight when loaded
- > Media on a sagging roll
- > Media that is rolled unevenly

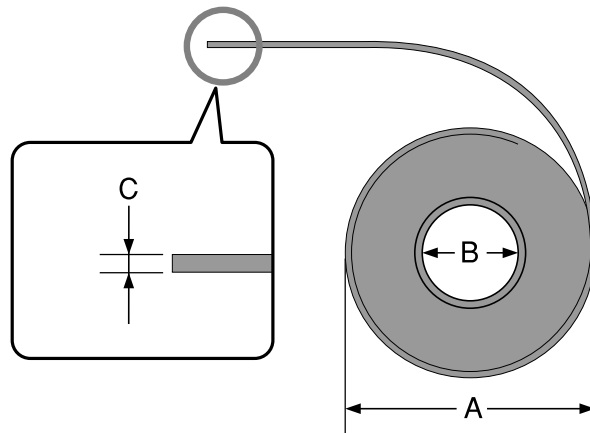

This machine cannot necessarily print every kind of media. When selecting media, be sure to carry out testing in advance to make sure that satisfactory printing quality is obtained.

7-2 Printing Area

Printing Area and Margins

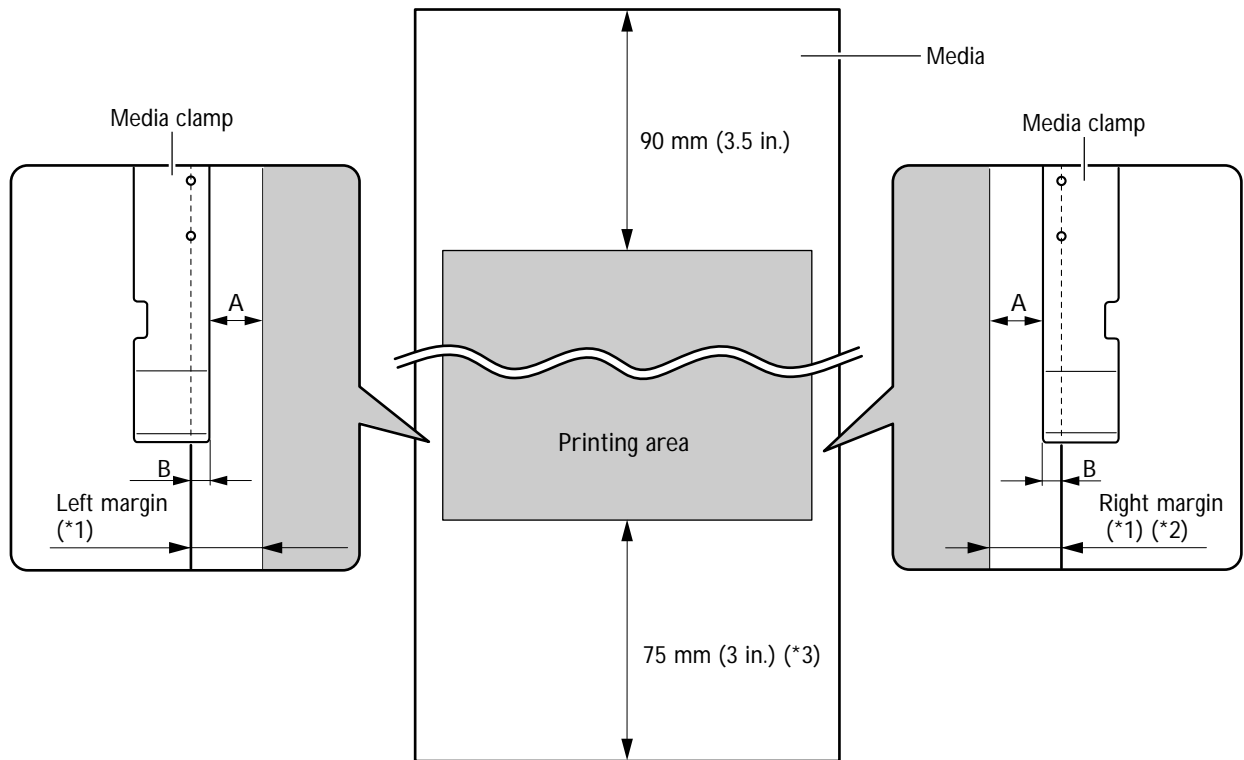

A: Setting of the [SIDE MARGIN] menu item (10 mm or 5 mm; 10 mm by default)

B: Width clamped by the media clamp (approx. 5 mm)

*1 The amount of the left and right margins is the total of A and B. In the following cases, however, the setting for A becomes the amount of margin without change.

- > When media has been loaded without installing the media clamps and **SET UP** has been pressed
- > When the [SHEET TYPE] menu item is set to [CLEAR] (regardless of whether the media clamps are present)

*2 The amount of margin can be changed by using **BASE POINT**.

*3 Margin length required by the media take-up and feed systems is approximately 1,100 mm (43 in.).

Media-cutoff Location During Continuous Printing

When a media-cutoff command is sent from the computer, the cutoff location on the media is as shown in the figure below.

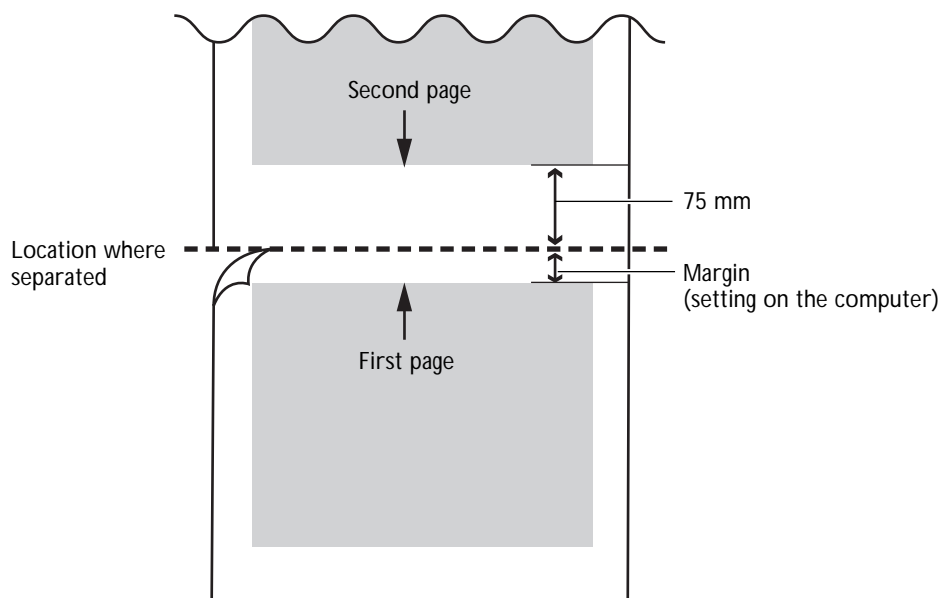

7-3 Locations of the Power Rating and Serial Number Labels

Serial Number

This is required when you seek maintenance, servicing, or support. Never peel off the label or let it get dirty.

Power Rating

Use an electrical outlet that meets the requirements for voltage, frequency, and amperage given here.

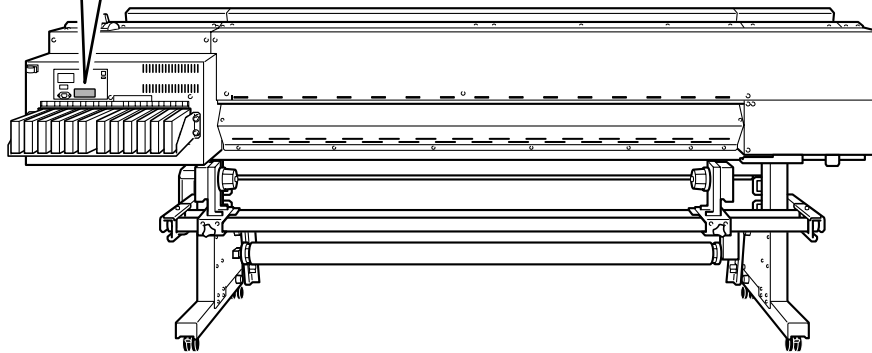

7-4 Specifications

		XJ-740	XJ-640	XJ-540
Printing technology		Piezoelectric inkjet		
Media	Width	210 to 1,879 mm (8.3 to 74 in.)	210 to 1,625 mm (8.3 to 64 in.)	210 to 1,371 mm (8.3 to 54 in.)
	Thickness	Maximum 1.0 mm (39 mil) with liner		
	Roll outer diameter	Maximum 210 mm (8.3 in.)		
	Roll weight	Maximum 47 kg (103 lb.)	Maximum 40 kg (88 lb.)	Maximum 30 kg (66 lb.)
	Core diameter	76.2 mm (3 in.) or 50.8 mm (2 in.)		
Printing width (*1)		Maximum 1,869 mm (73.6 in.)	Maximum 1,615 mm (63.6 in.)	Maximum 1,361 mm (53.6 in.)
Ink cartridges	Types	220-cc cartridge / 440-cc cartridge		
	Colors	6 colors (cyan, magenta, yellow, black, light-cyan, and light-magenta) or 4 colors (cyan, magenta, yellow, and black)		
Printing resolution (dots per inch)		Maximum 1,440 dpi		
Distance accuracy (*2) (*3)		Error of less than $\pm 0.3\%$ of distance traveled, or ± 0.3 mm, whichever is greater		
Media heating system (*4)		Preheater and print heater, setting range for the preset temperature: 30 to 50°C (86 to 122°F) Dryer, setting range for the preset temperature: 30 to 55°C (86 to 130°F)		
Media take-up system	Roll outer diameter	Maximum 250 mm (9.8 in.)		
	Roll weight	Maximum 50 kg (110 lb.)		
Connectivity		Ethernet (10BASE-T/100BASE-TX, automatic switching)		
Power-saving function		Automatic sleep feature		
Power requirements		AC 100 to 120 V $\pm 10\%$, 13 A, 50/60 Hz or AC 220 to 240 V $\pm 10\%$, 7 A, 50/60 Hz		
Power consumption	During operation	Approx. 1,600 W		
	Sleep mode	Approx. 47 W		
Acoustic noise level	During operation	64 dB (A) or less (according to ISO 7779)		
	During standby	45 dB (A) or less (according to ISO 7779)		
Dimensions (with stand)		3,169 (W) x 1,103 (D) x 1,260 (H) mm (124.8 (W) x 43.4 (D) x 49.6 (H) in.)	2,948 (W) x 1,103 (D) x 1,260 (H) mm (116 (W) x 43.4 (D) x 49.6 (H) in.)	2,694 (W) x 1,103 (D) x 1,260 (H) mm (106 (W) x 43.4 (D) x 49.6 (H) in.)
Weight (with stand)		225 kg (495 lb.)	213 kg (469 lb.)	200 kg (440 lb.)
Environmental	Power on (*5)	Temperature: 15 to 32°C (59 to 90°F) (20°C [68°F] or more recommended), humidity: 35 to 80%RH (non-condensing)		
	Power off	Temperature: 5 to 40°C (41 to 104°F), humidity: 20 to 80%RH (non-condensing)		
Accessories		Exclusive stands, power cord, media clamps, media flanges, replacement blade for separating knife, cleaning kit, software RIP, User's Manual, etc.		

*1
The length of printing is subject to the limitations of the program.

*2
 > With Roland PET film, print travel: 1 m
 > Temperature: 25°C (77°F), humidity: 50%

*3
Not assured when the print heater or dryer is used.

*4
 > Warm-up is required after powerup. This may require 5 to 20 minutes, depending on the operating environment.
 > Depending on the ambient temperature and media width, the preset temperature may fail to be reached.

*5
Operating environment

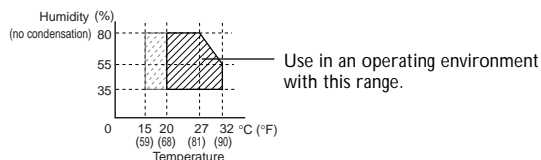



1000003535

R2-080509