



Heinzmann GmbH & Co. KG
Electric Drives

Am Haselbach 1
D-79677 Schönau (Schwarzwald)

Telefon 07673 8208-313

Installation and Operating Instructions

Retrofit Kit Electric Drive for Pedal Cycles

F 08 001 –e / 06-08

Contents

1	General	5
1.1	Symbols used	5
2	Cycle Types	6
2.1	Pedelec	6
2.2	E-bike	6
2.3	E-bike Speed	6
3	Safety Information	7
3.1	Caution for certain users	8
3.2	Permitted Applications	8
3.3	Rider requirements, Road traffic legislation, Insurance	8
3.4	Weights, Loading	9
4	Retrofit Kit Components	10
5	Installation of Retrofit Kit	12
5.1	Requirements and Preparation	12
5.2	Motor Spoking	13
5.3	Drive wheel installation	14
5.4	Luggage Carrier mounting	15
5.5	Twist Grip mounting	17
5.6	Pedal Sensor mounting (only Pedelec and E-bike Speed)	19
5.7	Fitting Cable to Control unit	22

5.8	Connecting Cable to Control unit	24
5.9	Control Unit mounting.....	25
5.10	Securing Battery on Luggage Carrier	26
5.11	Connecting Battery	27
6	Battery	28
6.1	Lithium-Ion Battery	28
6.2	Charging the Battery.....	30
7	Before the first ride	33
8	Rider Operation	34
8.1	Safety Notes for Riding	34
8.2	Twist Grip.....	35
8.3	Battery Status Display	38
8.4	Fault Display.....	39
8.5	Start.....	41
8.6	Riding	42
8.7	End of Ride	43
9	Maintenance and Cleaning	44
10	Transport by Vehicle	45
11	Correction of Defects	46
12	Warranty and Limit of Liability	50
13	Disposal.....	52
14	Technical Data.....	53

Congratulations. You have decided on the purchase of a Retrofit Kit for Electric Drive of a Pedal Cycle. We are very happy that you have decided to buy this product from the HEINZMANN company! It has been carefully considered and constructed and shows this through its performance, ease of operation and maintenance as well as reliability. We wish you much enjoyment and a pleasant journey with your electro-cycle and thank you for your confidence in us.

So that you may enjoy the full benefits offered by this product, please read these instructions completely through in quiet. In case you have decided not to have the retrofit kit fitted by a specialist workshop, preferring to build it yourself, take extra note of the section on Installation of Retrofit Kits.

The manufacturer reserves the right to introduce changes into the construction without notice which are considered to lead to a technically improved product.

Re-printing, reproduction or translation of this document, or sections thereof, is not permitted without approval. All legal rights as originator are expressly retained.

1 General

1.1 Symbols Used

Important notes for your safety are specially marked. Ensure these notes are followed in order to avoid injury or damage to the product.



Warning

WARNING:

Warns of danger to your health and possible risks of injury.



Attention

ATTENTION:

Warns of possible endangering of equipment and other obstacles.



Note

Note:

Advises on tips and special information.

2 Cycle Types

All the following types of electro-cycle can be operated by pedalling alone, as with ordinary cycles, as well as operating in mixed mode through pedalling and with motor power.

2.1 Pedelec

The *Pedelec* (Pedal Electric Cycle) is a pedal cycle with integrated electric drive. Its motor supports the forward pedalling up to a maximum speed of 15mph, subject to configuration. The level of support from the drive is controlled in step-less fashion with help of the twist-grip.

The *Pedelec* may also be fitted with a start-help function, which allows the cycle to be supported up to 3.5mph without pedalling, simply by turning the twist –grip.

Motor drive alone without pedalling is not possible except in the case of the start-help function.

2.2 E-Bike

Das *E-bike* is a pedal cycle with integrated electric drive. It can provide motor support without pedalling up to a maximum speed of 15mph, subject to configuration. The riding speed is determined by the rider by turning the twist-grip

In UK, registration of an e-bike restricted to 15mph as above is not required.

2.3 E-Bike Speed (not UK Road Legal)

The *E-Bike Speed* is a pedal cycle with integrated electric drive. It can be ridden with motor support alone up to a maximum speed of 12.5mph, subject to configuration. The ridden speed is determined by the rider by turning the twist-grip. Above this, the motor drive supports the rider pedalling forwards up to a maximum speed of approximately 28mph.

The *E-Bike Speed* is permitted in Germany under the light-moped laws. In UK, such registration is not possible and, due to the maximum speed achievable, this cycle is not permitted to be ridden on public roads.

3 Safety Information

Before use of associated products read these notes completely!

Take good note of information! In case the product is passed to a third party, these instructions must also be passed on.

Failure to follow this information could lead to injury or equipment damage. For damage, arising from a failure to follow this information, the manufacturer accepts no liability.



Warning

WARNING:

While there is no obligation for the rider to use a helmet when riding an EAPC (Electrically Assisted Pedal Cycle) we strongly recommend that a suitable helmet is worn to increase personal safety.



Attention

ATTENTION:

Retrofit Kit installation should be undertaken by a suitably qualified bike technician, as incorrect installation could prevent correct operation of the electric drive functions. Self assembly should only be undertaken by persons with suitable knowledge and experience.



Attention

ATTENTION:

A damaged motor can lead to damage of other components and must be replaced.



Attention

ATTENTION:

Damaged electric assemblies and cables can lead to short-circuit and must be replaced.

3.1 Caution for Certain Users

- Children under 14 years old are not permitted to ride (be in control of) Electrically Assisted Pedal Cycles (EAPCs).
- The product must be kept away from children and other persons who may not be able to assess the associated risks.
- Packing materials are not children's toys! There is risk of injury and poisoning. Should small parts be swallowed, seek medical assistance urgently.

3.2 Permitted Applications

The Retrofit Kit serves to convert a pedal cycle to an electric cycle.

The use in other products (e.g. wheelchair equipment, disabled user transport) is possible.

If necessary contact should be made with the drive manufacturer.



Attention

ATTENTION:

Non-permitted applications include especially :

- Combination with unapproved components
- Changes to components by unqualified or unauthorised persons.
- Overloading or inappropriate use of drive, e.g. racing or violent blocking of rotating drive e.g. riding into obstacles

3.3 Driver requirements, Road Traffic legislation, Insurance

By use of an electric cycle, locally valid laws for use of Electrically Assisted Pedal Cycles on public roads and requirements for riding on roads must be adhered to.

It is the rider's responsibility to make themselves aware of all valid legislation and bye-laws and adhere to them.

In United Kingdom the following are valid:

- *Pedelec* and *E-Bike* with or without Start Assistance:
Minimum Age 14 years, no driving licence, no insurance, no helmet required.
- *E-Bike Speed*:
May not be ridden on public roads.



Warning

WARNING:

Although no helmet must be worn, it is strongly recommended.

3.4 Weights, Loading

Legally fixed limits on cycle weights.

Cycle type	Maximum total weight	Maximum cycle weight without rider
Pedelec/E-Bike: bicycle	Not specified	40kg
Pedelec/E-Bike: tricycle	Not specified	60 kg

- Maximum cycle weight is given with one battery. A second unconnected battery qualifies as luggage.
- The maximum loading on the Luggage Carrier is 15 kg!

4 Retrofit Kit Components



- Unpack parts and remove packaging.
- Check parts for completeness and soundness.
The Retrofit Kit comprises:
 - A Wheel Hub Motor
 - B Twist Grip with Cable
 - C Luggage Carrier, Battery, Battery Case and Power Supply
 - D Control Unit
 - E Motor extension cable (for front wheel motors)
 - F Pedal Sensor complete, comprising Sensor and Cable, Sensor ring and fittings (for *Pedelec*)
- Make note of Serial Numbers
Serial number are on the nameplates of the motor, control unit, twist-grip and battery.



Note

NOTE:

The Serial Number is an exact, unique number with which the individual components are marked. With these numbers the parts may be clearly identified (e.g. for Bike shop, warranty, theft).



Note

NOTE:

In case of damage or shortages during transport, the sender must be informed immediately.



Attention

ATTENTION:

Transportation or shipping of equipment should be done using original, or other suitable packaging. Packaging no longer required should be disposed of carefully, in accordance with local legislation.

5 Installation of Retrofit Kit

5.1 Requirements and Preparation

- The cycle forks should preferably be made of Steel.
The forks should not be twisted.
Aluminium forks may only be used with permission of the forks manufacturer.
Use of suspension forks is only possible in consultation with a specialist cycle dealer.
- Required installation width: Front wheel min. 100 mm
 Rear wheel min. 135 mm (Standard)
- Only 36-hole rims may be used. Eyeleted double wall rims are preferred.
- The twist-grip must be mounted on the right hand side of the handlebar. Accordingly it may be necessary to move the gear shifters to the left hand side or install shifters on the right hand side which can be operated safely and do not interfere with safe operation of the twist-grip.
- For the *Pedelec* retrofit kit fitting of the pedal sensor ring will need to be done on the main axle. For this a square taper axle is required with stop collar and sufficient remaining crank length for crank installation.



WARNING:

Alternatively, let the bike be tested by a specialist dealer to determine whether the bike is suitable for installation of a retrofit kit and carries the required stability.

5.2 Motor Spoking



WARNING:

Spoking of the motor should only be done by a specialist person! Incorrectly spoked wheels can lead to a bike fault and possible breakdown.



A



B



The required spoke lengths are different and dependent on:

- Rim Type
- Wheel diameter
- Front or rear drive
- Right or left side of wheel

The spoke lengths for left and right sides are different because the spoke flanges are differently positioned with respect to the wheel centre.

A: Front Wheel drive,
B: Rear Wheel drive

5.3 Drive Wheel Installation



Warning

WARNING:

After installation of the front or rear wheel, the torque arm of the spoked motor must always be on the left side.



Torque arm

Insert front wheel with spoked motor in the forks. (Rear wheel with motor in rear assembly).

Loosely fasten the torque arm with bracket, screw and nut to the forks (chainstay for rear assembly) in order to position the torque arm.

Tighten both nuts on the motor axle. Tightening torque 35 Nm.

Now tighten the torque arm bracket screw.

Raise wheel and rotate manually in driving direction.

The wheel must rotate freely and unrestricted. If the motor stops after a short time there may be a fault in the assembly requiring the motor installation to be checked. The motor housing must not interfere with other components (e.g. fastening screws).

Secure motor cable with cable ties:

Front wheel motor: To the fork

Rear wheel motor: To the rear seat post tube.

5.4 Luggage Carrier mounting



Warning

WARNING:

Maximum loading of 15kg permitted on Luggage Carrier, including batteries and control unit!



The luggage carrier can be adapted to individual cycle models:

- Via adjustable fixing bars to the upper fixings.
- Via various drillings on the lower part of the carrier and extension bar

During installation, the requirements in the instruction manual for the cycle particular model must be followed as necessary.

Mount the carrier so that the pack surface lies horizontally. Ensure that adequate space remains underneath the carrier for later fitting of the control unit.

Secure, loosely for now, the carrier at the upper fixings using two socket head screws.

Secure the carrier lower end adjacent the dropouts with help of the extension bar using two socket head screws and self-locking nuts.

Now securely tighten all screws so that the carrier is fixed in its final position.

Details for mounting the Luggage Carrier

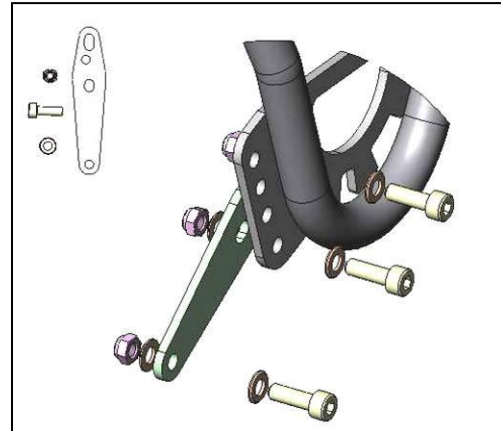
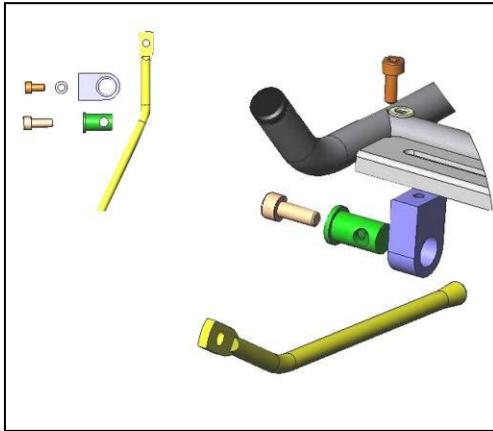

5.5 Twist-Grip Mounting



Grubscrews



Remove right handlebar grip.

As required remove right hand mounted gear shifters to left side or install suitable shifters to right side.

Select grubscrews for twist-grip fixing (2 required):

- Aluminium handlebar: Grubscrew with cup point
- Steel handlebar: Grubscrew with pin point

(Twist grips are supplied with grubscrews with cup point as standard.)

Insert grubscrews in twist-grip, if not already inserted. Ensure both grubscrews do not protrude beyond the casing with the risk of dragging on the handlebar during assembly. Unless this is ensured the twist-grip cannot be mounted.

Push twist-grip up the stop point on the right handlebar end and then pull away from stop by 5mm. If the twist grip is inserted too far the automatic return mechanism can be inhibited!

Tighten both grubscrews. Torque 1.5 Nm

Check twist-grip automatic return mechanism by turning the twist-grip back and releasing. The twist-grip must return to the start position immediately.

Close off installation opening of grubscrew with sealing cap.

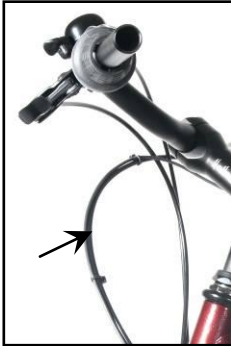

Tie twist-grip cable and brake and shifter cables together with cable tie or spiral wrap. Leave enough play to fully turn the handlebars in both directions.

5.6 Pedal Sensor Mounting (only *Pedelec*)



Warning

WARNING:

Mounting the pedal sensor is only possible on cycles with square taper axles.

If in doubt have the bike checked over by a specialist bike retailer. On no account should the frame be drilled as this can reduce cycle stability.



Note

NOTE:

For the disassembly/assembly of crank arm a suitable crank puller will be required. For disassembly/assembly of the bottom bracket a suitable bottom bracket spanner will be required. In case of questions refer to specialist bike retailer.

The pedal sensor is normally mounted on the right hand side as, for most bottom brackets, the stop ring for the chain protection bracket is found on the right.

For some bottom brackets the stop ring is on the left hand side (e.g. FAG bearings).

Assembly on the left side is easier although the sensor ring is left exposed to potential damage or dislocation.

Assembly in the right side is more complex, however; the sensor ring lies protected by the chain ring and away from harm.

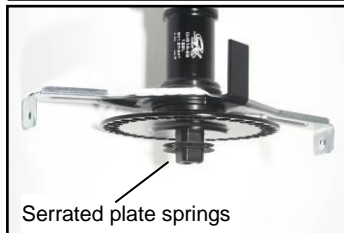
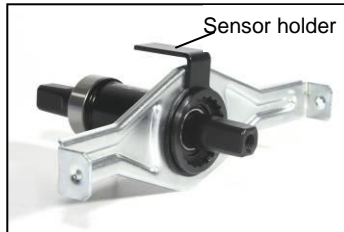

Mounting right:

Remove any chain protection as appropriate.

Remove chain and crank.

Unscrew bottom bracket using suitable bottom bracket spanner from bottom bracket housing (Caution left hand thread!)

Remove chain protection bracket.

Push sensor holder onto axle up to the stop ring.

Replace chain protection bracket (as appropriate) onto axle.

Re-screw bottom bracket into housing and, using bottom bracket spanner, tighten (check with bottom bracket manufacturer for tightening torque).

Check that the sensor holder is lightly retained.

Push sensor ring onto bottom bracket axle with straight, uncurved side first.

Push both serrated plate springs onto axle so that their teeth touch one another. If necessary, instead of the serrated plate springs, use the spring washer.

After fastening of the crank the serrated plate springs will press against the sensor ring holding it in its optimal position. The sensor ring should rotate precise and in a single plane when mounted correctly.

Re-assemble crank (check torque with manufacturer's guidelines)



Sensor

Re-assemble chain protection if required.

Place the sensor on the sensor holder foam pad so that:

- It lies parallel to the bottom bracket
- Distance between sensor pick-up surface and sensor ring is between 0.5 to 1.5 mm
- The nose on the side of the sensor is so orientated that it points towards the centre of the bottom bracket. Without this the sensor is unable to detect correct crank rotation,

Fasten sensor to sensor holder using cable ties.

Mounting left:

Remove left crank.

Remove left bottom bracket casing with bottom bracket spanner.

Push sensor holder up to the stop on the bearing housing.

Re-screw bottom bracket using bottom bracket spanner into bottom bracket housing. The sensor holder should be loosely positioned.

Push sensor ring onto bottom bracket axle with straight, uncurved side first.

Push both serrated plate springs onto axle so that their teeth touch one another. If necessary, instead of the serrated plate springs, use the spring washer.

After fastening of the crank the serrated plate springs will press against the sensor ring holding it in its optimal position. The sensor ring should rotate precise and in a single plane when mounted correctly.

Re-assemble crank (check torque with manufacturer's guidelines)

Place the sensor on the sensor holder foam pad so that:

- It lies parallel to the bottom bracket
- Distance between sensor pick-up surface and sensor ring is between 0.5 to 1.5 mm
- The nose on the side of the sensor is so orientated that it points away from the centre of the bottom bracket. Without this the sensor is unable to detect correct crank rotation,

Fasten sensor to sensor holder using cable ties

5.7 Fitting Cable to Control Unit



Note

NOTE:

As the control unit will be mounted under the luggage carrier, it is advisable to run the cable and test-connect to the unmounted control unit. Once the required cable lengths have been tested the control unit can be fitted. Fixing of the cable is performed using cable ties.



Warning

WARNING:

To avoid incident all cables must be run so that:

- Full handlebar movement as possible
- Rotating parts (chain drive, cranks, wheels) are not affected
- Feet are not restricted during pedalling
- Cables should neither be allowed to hang loose nor held in tension.



Warning

WARNING:

When running the motor cable between forks and frame a bend radius of at least 6cm is required. Without this full steering could be inhibited.



Front wheel motor:

Connect extension cable and motor cable together and run along fork.

Run extension cable and twist-grip cable together along the main downtube.

In the case of *Pedelec* run both cables along with the sensor cable behind the seat-post tube.

Rear wheel motor:

Run twist-grip cable along main downtube.

In the case of *Pedelec* run cable along with the sensor cable behind the seat-post tube.

5.8 Connect Cables to Control Unit



Note

NOTE:

Orientation of Control Unit: Key Switch in ride-direction, left, cover underneath.

- Sensor connector
(only with *Pedelec*):
Push sensor plug to socket and secure by screwing screw casing right.
For removal of the plug first unscrew screw casing left and then remove plug.
- Twist-grip plug:
Push plug into socket and secure by screwing screw casing right. For removal of the plug first unscrew screw casing left and then remove plug.
- Motor cable /Extension cable (front wheel motor):
Push plug into socket and turn right until an audible click is heard from the locking ring.
For removal, push locking ring back, turn plug until stop. Withdraw plug.

5.9 Control Unit Mounting



Note

NOTE:

Cables connected to the control unit and lying between control unit and seat-post tube should be tied together with cable ties so that they do not hang down.



Insert two countersunk screws through the countersunk holes in the carrier top plate and then through the fixing slots right and left of the control unit.

Fix and tighten the screws with self locking nuts.

5.10 Securing Battery on Luggage Carrier



Warning

WARNING:

Take care when hanging and removing batteries on the carrier that fingers do not get squashed!

Fixing the Battery Case:

The battery case should ideally be fastened to the right hand side of the carrier. To achieve this two fixing hooks and two fixing brackets are provided.

The brackets should be set up for the first mounting. Loosen the black clamping screws on the open side of the brackets. Then move the brackets sideways to suit the carrier bars. Once this has been achieved satisfactorily screws should once again be tightened.

Open both bracket latches (red), by pushing the catches in towards the battery case.

Carefully insert both fixing hooks behind the carrier bars.

Hang both battery case fixing hooks on the upper fixing bar simultaneously and press down until a stop is reached.

Close the latches by pushing the red catches away from the battery case over the fixing bar. Correct latching will be accompanied by an audible click.

Removal of Battery Case:

First ensure that the connection to the battery has been removed. (See “Removal of Connector”).

Open both latches (red) so that the catches push toward the case.

Pull the battery case smoothly upwards.

Disengage the lower hooks from the carrier bars.

5.11 Connecting Battery



Note

NOTE:

The battery cable should always be led into the battery case from below so that water cannot flow directly into the battery case. Velcro cable fastenings are provided to secure the cable to the side of the battery case.



Ensure that the control unit key switch is turned to “OFF”.

Insert battery cable plug from control unit into the socket on the battery. Differently keyed profiles in the plug and socket will ensure correct orientation.

Turn plug right until an audible click of the locking ring is heard.

Removal of Connector:

- Push plug locking ring away from socket.
- Turn plug left until the stop.
- Remove plug.

6 Battery

6.1 Lithium-Ion-Battery

The Retrofit Kit is supplied with a Lithium Ion Battery as its drive voltage source. The type of battery is particularly light whilst having a very high charge capacity. Accordingly its dimensions make it compact and easy to store in its accompanying pannier case.

Li-Ion batteries should only be charged with special charging devices! Conditioning and correct charging as well as protection from overcharging or deep discharging and overheating is essential for maintaining along life expectancy. A suitable charging unit, which considers all these requirements, is, therefore, already integrated into the battery housing to ensure optimal and secure functionality. In order to charge the Li-Ion battery, only a power supply is, therefore, necessary. One such unit is included as component of the Retrofit Kit.



Warning

WARNING:

Only the power supply supplied with the kit should be used.

Before connecting the power supply to the mains, a check should be made to establish that the mains voltage and power supply voltage are compatible. The connection voltage of the power supply is given on the unit's nameplate.

The power supply is suitable for inside use only.

The Li-Ion battery may only be charged in dry conditions and in a non-flammable environment.



Warning

WARNING:

A power supply with damaged mains cable must not be used and should be inspected and repaired by a suitably qualified technician. The same applies for extension cables.

Ingress of water or high humidity in the power supply must be avoided at all costs. In the event that water is allowed to enter the power supply it should be disconnected from the mains immediately and inspected by a suitably qualified technician.

Following a sudden change in ambient temperature from cold to warm, it is possible for condensation to build on the power supply. In such a case, wait a while until the power supply has warmed up to the same temperature as its new environment. To help avoid this happening, the power supply should be stored in the same place as it will be operated.

The battery may only be used in conjunction with the supplied motor.
Other applications are not permitted.

The power supply may only be used for charging the associated battery.
Other applications are not permitted.

Modification, in any manner, of the power supply or battery case is not permitted!

Mechanical damage of the battery must be avoided at all costs. (Risk of explosion!)

During the charging operation the power supply must not be stored or located within the battery case as this may lead to excessive heat generation.

6.2 Charging the Battery

Normally the battery will leave the factory fully charged. As the battery is expected to self-discharge (~1% per day at room temperature) it should be first fully charged prior to first use.

Charging may take place on the luggage carrier as well as with the battery case removed from the carrier.



The battery status is shown on the operating unit of the twist grip as well as on the battery itself.

To view status on the battery, shortly depress the button on the top of the unit. The battery status will be displayed for a few seconds with up to 4 LEDs.

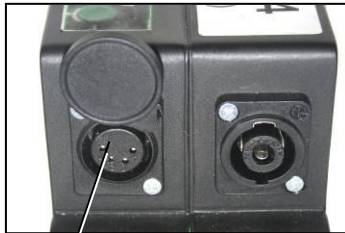

Charging socket

For charging the following steps must be adopted:

- Reveal charging socket by sliding the protective cover aside.
- Connect power supply to the mains.
- Insert charging plug into charging socket.
The battery status LEDs will begin to blink

Charging status on battery during charging:

1 LED blinks, up to 3 LEDs lit	Battery charging. Number of lit LEDs shows the already charged battery. Number of blinking LEDs shows capacity yet to be charged.
4 LEDs lit	Battery is nominally fully charged, Post-charging active.
All LEDs unlit	End of charging reached. Battery is 100% charged. Compensation charging active.

Charging time:

A full charging of an empty battery lasts:

- Ca. 4 h with battery type 5.2 Ah
- Ca. 7.5 h with battery type 9.6 Ah

When the end of charging is reached the charger switches to compensation charging. The battery may be left indefinitely connected in this condition. This has the advantage that the battery is always fully charged.

The battery may be used with the drive at any time, even when charging is not complete. Of course this means that the range will be limited compared with that possible on a full charge.

**NOTE:**

In contrast to other battery types the Li-Ion battery does not experience “memory-effect”. That means it does not need to be fully discharged before charging. It actually improves the life expectancy when the charging cycles are regular, i.e. placed on charge directly after use.

**NOTE:**

The ambient temperature during charging should ideally be between +10°C and +30°C. Charging outside this range limits the available charge capacity and therefore range. With freezing outside temperatures it is essential to charge the battery in a heated room. Direct sunlight or heat sources should be avoided.

**NOTE:**

Before a long idle period e.g. winter break, the battery should be fully charged and stored in a dry and frost-free environment. Before using the battery again a full charge should be applied.

**NOTE:**

During long journeys with high motor power, the battery can become warm significantly. A temperature monitoring within the battery case prevents charging when the battery temperature is too high. In such cases the power supply may be left connected. The charging cycle will commence once the battery temperature has cooled sufficiently. This cooling time can be up to an hour after, for example, long hill climbing.

7 Before the First Ride



WARNING:

After installation of the retrofit kit a safety inspection should be carried out by a specialist workshop to determine correct installation and suitability for road use. It is recommended that your electric bike be inspected by a specialist workshop every 300 miles.

Before every ride a safety check should be undertaken to help avoid potential accidents. To this end the cycle operating manual should be to hand should anything require adjustment.

Regularly check the following and ensure:

- Sound attachment of torque arm to forks (chainstay)
- Sound installation of motor (spokes, axle nuts) and of motor connector
- Sound location of battery on luggage carrier.
- Sound attachment of twist grip to handlebars, before switching on check automatic return mechanism
- Undamaged cables and secure attachment to frame
- Sound attachment of all screws and nuts.
- Safe operation of brakes, brake shoes not dragging on rims.
- Suitable tyre pressure. (max. pressure is marked on each type - approx 3-4 bar)
- Light running of all bearings (bottom bracket, wheels, steering) and quiet wheel running.

Allow any defects to be corrected by a suitably qualified workshop.

8 Rider Operation

8.1 Safety Notes for Riding

- The electric bike must always be kept in road-suitable condition to maintain individual safety and that of other road users.
- For improved road safety a rear view mirror should be used.
- The weight of the Retrofit Kit and added motor power will have a not inconsiderable influence on the cycle's ride characteristics. Because of the greater weight, a greater braking distance should be calculated. Safely mastering the electric bike should, therefore, firstly be practised away from traffic.
- Before riding off, check brake effectiveness by a brake test.
- When braking, always use both brakes together. Never activate the driven wheel's brakes alone or before the other brake.
- Always ride cautiously on wet, greasy or loose surfaces. Jerky turning of the twist-grip and jerky pedalling should be avoided.
- On fast curves and on uneven cambers, never push the inside pedal down, so as to avoid clashing with the road surface and a potential accident.
- Never ride with free hands.
- Use lights during darkness and periods of poor visibility in order to be seen by other road users.
- Wearing of a cycle helmet for personal safety is recommended.
- Continued operation in salt-laden environments should be avoided as this will encourage corrosion damage.

8.2 Twist-Grip



Mounted on the twist-grip can be found display and operating unit with pushbuttons and Light Emitting Diodes (LEDs).

Pushbutton:	LED:
ON/OFF (red)	1 (green)
ECO (green)	2 (green)
	3 (yellow)
	4 (yellow)
	5 (red)
	6 (green) - ECO

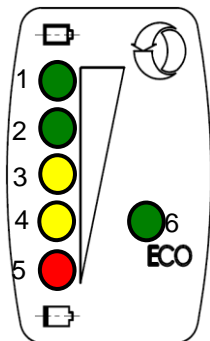

Pushbuttons

The larger red pushbutton with the text “ON/OFF” switches the drive on and off and lights the LEDs.

The right, green LED with the text “ECO” permits switching between Eco and Standard modes.

Functions

- Switch On

Press the pushbutton “ON/OFF” for longer than 1 second.

Whilst the pushbutton is pressed one LED will blink (green)

Release pushbutton once the display changes.

The extended operation of the pushbutton is designed to avoid unintentional switching-on of the unit.

As a further safety feature, switching-on is only possible when the twist-grip is in the zero-position (against its return stop).

If the twist-grip is not in the zero-position when switched on, red LED 5 will blink after around one second and additionally LED 1. If the twist-grip is now turned to the zero-position LED 5 is turned off and the drive is enabled. (see also table “Error Display”).



Warning

WARNING:

For safety reasons, the twist-grip should never be turned to full throttle during this condition.

- **Switch Off**

Press pushbutton “ON/OFF” until all LEDs are extinguished (approx one second).

- **LED Brightness**

After switching on the LEDs are illuminated to suit daylight conditions. The brightness can be reduced to suit dimmed conditions or darkness.

With the drive switched on press pushbutton “ON/OFF” for around 0.5 seconds. Whilst pressed LED 1 blinks. Brightness selection is carried out by releasing the pushbutton. If pressed too short no alternative brightness is selected. If the pushbutton is pressed again the increased brightness is restored.

- **Selection Eco-/Standard mode**

The drive has two operating modes, Standard or Eco mode. (see table) In Eco mode the motor current is reduced. The operating time of batteries can, in this way, be increased.

After switching on the Eco-mode is automatically selected and LED 6 is illuminated.

Switching off Eco-mode is effected by short pressing of the Eco pushbutton. LED 6 is extinguished and Standard becomes active.

Pressing the Eco pushbutton again restores Eco-mode and LED 6 is illuminated.

Characteristic	Standard-Mode	Eco-Mode
Riding Speed	Same	
Maximum motor power	Higher	Lower
Ride experience	More powerful	Smoother
Range	Lower	Higher

8.3 Battery Status Display

On the top of the display and operating unit on the twist-grip six LEDs can be found which show the battery charge and operating status.

Solid illumination of each of the LEDs 1 to 5 shows the battery status in accordance with the table.

When LED 5 blinks the battery is almost empty. The control unit will, shortly thereafter, shut the battery down to protect it from deep discharge.

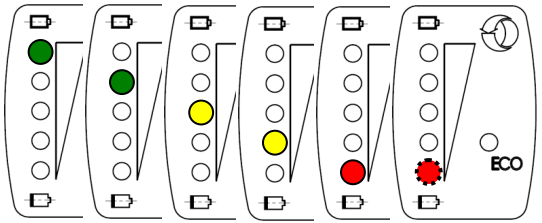
LED-Status	Battery Charge Status	
1 (green) on	100 - 86%	
2 (green) on	86 - 72%	
3 (yellow) on	72 - 58%	
4 (yellow) on	58 - 44%	
5 (red) on	44 - 30%	
5 (red) blinks	< 30%	

8.4 Error Display

(Recovery from errors is described in Section 11)

LED-Status	Possible cause	Error type	
1 (green) lights, 4 (yellow) blinks	<ul style="list-style-type: none"> - Motor overheated - Control unit overheated - Motor plug not connected or inadequate contact 	Self resetting, when the problem is resolved.	The diagram shows a vertical column of seven LEDs. The top LED is illuminated green. The next four LEDs are shown as yellow circles with radiating lines, indicating they are blinking. The bottom LED is unlit. To the right of the LEDs is a circular 'ECO' button and a power button icon.
1 (green) and 5 (red) blinking alternately	Twist-grip not in zero position (return position) at switch-on. WARNING: Never turn twist-grip to full throttle during this condition	Self resetting, when the problem is resolved.	The diagram shows a vertical column of seven LEDs. The top LED is illuminated green. The next five LEDs are shown as red circles with radiating lines, indicating they are blinking alternately. The bottom LED is unlit. To the right of the LEDs is a circular 'ECO' button and a power button icon.

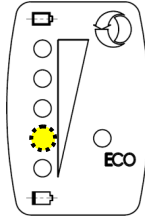
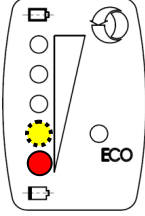
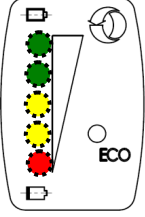
LED-Status	Possible cause	Error type	
4 (yellow) blinks	No communication between control unit and battery NOTE: The motor is still operable during this error mode!	Not self resetting	
4 (yellow) blinks, 5 (red) lights	General error	Not self resetting	
All blinking (in varying sequence)	No communication between control unit and twist-grip	Not self resetting	

8.5 Start



Warning

WARNING:

With a defect in the twist-grip automatic return mechanism the electric cycle must not be ridden. The error should be resolved by a specialist workshop.



Note

NOTE:

Before starting, always check the twist-grip automatic return mechanism.



The system must initially be switched off! To check the twist-grip automatic return mechanism turn the twist-grip back and release (see picture). The twist-grip must return to the zero-position immediately.

Remove protective cap from control unit lock.

Insert key into lock and switch ON.

Remove key so that the key is not lost during the ride. Replace the protective cap over the lock.

Mount the electric cycle.

First press the “ON/OFF” pushbutton on the twist-grip (longer than one second – see also section 7.2).

Ride off by pedalling as with an ordinary cycle.
By smooth turning of the twist-grip the motor is enabled.

8.6 Riding



Warning

WARNING:

Never block or inhibit the twist-grip automatic return mechanism during a ride!

In order to increase motor assistance after setting off and speed up the ride turn the twist grip further backwards and additionally pedal harder.

To reduce motor assistance turn the twist-grip smoothly forwards.

If during the ride the ride speed increases, a higher gear should be selected. If the pedals are turned too slowly the control unit will disable the drive system. As the ride speed decreases, e.g. whilst hill climbing, a lower gear should be selected.

In order to switch the drive off whilst riding, when, for example, only pedalling is required, without motor support, or during long level sections, or downhill, the following should be adopted:

- Smoothly turn twist-grip forwards to the zero-position.
- Press “ON/OFF” pushbutton for at least one second until all LEDs are extinguished.



Note

NOTE:

As *Pedelec* the cycle may be motor assisted up to 3.5mph without pedalling by use of the Start Assistance.

The Start Assistance for *Pedelec* is also useful when pushing the cycle is necessary.

As E-Bike the cycle may be ridden up to 15mph without any pedalling.



Note

NOTE:

The electric drive will switch itself off when:

- The battery reaches its deep discharge limit.
- Motor or control unit overheated. This is possible after e.g. long hill climbing or extended, uninterrupted riding with a second battery.
After a short cool down time (5-10 minutes) the drive is again useable.

8.7 End of Ride

Smoothly turn twist-grip forwards towards the zero-position. (auto return position)

Bring electric cycle to a full stop by use of front and rear brakes.

Press the “ON/OFF” pushbutton for at least 1 second until all LEDs are extinguished.

Remove protective cap from control unit lock.

Insert key into lock and turn to “OFF”.

If a long pause is to be made, remove the key (to protect against unpermitted use) and replace protective cap.



Note

NOTE:

If switching off has been forgotten, the control unit will turn the system off after around 16 minutes automatically. Before riding again the “ON/OFF” pushbutton must again be pressed.

9 Maintenance and Cleaning



Warning

WARNING:

Service work should only be undertaken by a specialist workshop

With approved and careful use the electric drive is maintenance free.

Every 300 miles a safety inspection should be carried out by a specialist workshop on the cycle. The following, at least, should be checked:

- Secure fastening of all cables and parts.
- Function of complete electric parts.
- Operational safety of battery



Warning

WARNING:

Before cleaning turn the keyswitch to “OFF”!



Attention

ATTENTION:

The use of steam cleaners, high pressure cleaners or water hoses is not permitted. Ingress of water into the electrics or motor can lead to motor or equipment damage.

The Retrofit Kit components can be cleaned with a soft damp cloth with ordinary soapy water. This should be applied damp rather than wet. For cleaning of the cycle, please refer to the associated operating and maintenance instructions.

10 Transport by Vehicle

Aggressive road grime, rain water or salt-laden air will reduce the life expectancy of the electric cycle. If the cycle is to be transported on the outside of a vehicle, a suitable cover, designed for such use, is recommended. For transporting, the batteries should be removed and stored in the vehicle in a cool spot away from sunlight.

11 Error Resetting



Warning

WARNING:

Error investigation and resetting should only be undertaken by a suitably qualified specialist workshop. Work on batteries and power supplies should, also, only be undertaken by a suitably qualified specialist workshop.



Warning

WARNING:

Any work must only be undertaken with the drive at full standstill and switched off.



Warning

WARNING:

Before operating the drive again, all covers, fastenings, and safety devices should be correctly fitted and checked for proper function.



Note

NOTE:

For error investigation and resetting the cycle manual operating and maintenance instructions should also be referred to.

If an error exists, the following table will determine whether the error can reset itself or whether reference to a specialist workshop is required.

In the event of a drive system fault arising during a ride, the cycle should still be rideable with the drive systems switched off.

Error	Possible Cause	Solution
Drive won't turn on – LEDs on twist-grip won't illuminate.	Key switch still at “OFF”	Turn key switch “ON”
	Battery empty	Charge battery
	Battery defective	Refer to specialist workshop / replace with new battery
	Twist-grip or battery connectors insufficient contact	Check connectors for correct connection
	Twist-grip defective	Refer to specialist workshop
After switching on, the motor cannot be started. LEDs 1 and 5 blink alternately	Twist-grip not in zero-position (sticking or slightly turned)	If the twist-grip sticks, do not ride off with motor assist. Refer to specialist workshop. If possible, release the twist-grip so that it returns to the zero-position. WARNING: During this error condition, never turn twist-grip to full throttle.
	After switching on LED 4 blinks	No communication with battery.
Incompatible battery fitted		Fit compatible battery
After switching on LED 4 lights and LED 5 blinks	General Error	Switch drive off and on again. If error remains, refer to specialist workshop.
After switching on all LEDs blink in varying sequence	No communication with twist grip	Switch drive off and on again. If error remains, refer to specialist workshop.

Drive switches off during ride	Motor or control unit overheated LED 1 lights, LED 4 blinks	Switch drive off and leave to cool for 5-10 minutes before switching on
	Battery empty	Charge battery
	Connectors have insufficient contact	Check all connectors for correct connection
	Control unit defective	Refer to specialist workshop
Range too low	Battery empty	Charge battery
	Battery defective	Refer to specialist workshop / replace with new battery
	Cycle condition of riding operation not ideal.	<ul style="list-style-type: none"> ▪ Check technical soundness of cycle. (Tyre pressure, smoothness, no rubbing) ▪ Adopt different riding style (less aggressive use of twist-grip, harder pedalling)
<p>Pedelec:</p> <p>Motor runs with start assistance but does not go faster when pedalling or only partially.</p>	Pedal sensor incorrectly set-up	<ul style="list-style-type: none"> ▪ Check and correct distance between sensor and sensor ring ▪ Check location and orientation of sensor nose ▪ Check sensor ring runs in single plane. (no wobble)
	Sensor defective	Refer to specialist workshop / replace sensor
	Sensor connector insufficient contact.	Check connector contact
	Control unit defective	Refer to specialist workshop

Pedelec: Increased pedal power required to keep riding.	Incorrect, too high gear.	Select lower gear
	Incline or load too much	<ul style="list-style-type: none"> ▪ Select lower gear ▪ Pedal harder, ▪ Turn twist-grip to give more throttle.
	Motor defective	Refer to specialist workshop
Only limited motor power. Motor doesn't turn or only slowly and weak.	Battery empty	Charge battery
	Motor overheated	Switch drive off and allow to cool for 5-10 min.
	Connectors have insufficient contact	Check connectors for correct connection.
	Motor temperature sensor defective.	Refer to specialist workshop
	Control unit defective	Refer to specialist workshop
	Battery has reached end of life.	Check battery with specialist workshop /replace with new battery.
Exceptional motor noise	Motor damage	Do not ride further with motor. Refer to specialist workshop
Motor runs with audible running sound, but does not drive cycle	Motor gear damage (gear teeth, freewheel)	Refer to specialist workshop
Twist-grip sticks	Twist-grip slipped, incorrectly installed or defective mechanism	Do not ride further with motor. Refer to specialist workshop

12 Warranty and Limit of Liability

We, the HEINZMANN GmbH & Co. KG (Manufacturer) company, in accordance with legal obligations for warranty provision and in the case of a failing in our products provide the following to our direct customer:

1. Removal of defects, which result from material or manufacturing errors, through repair or exchange of the affected parts, in accordance with legal requirements, within a period of 24 months from date of manufacture to the direct customer. Consumables not included (e.g. Battery). The manufacturing date is displayed on the nameplate.
2. Emotive Control Systems Ltd (UK distributor) warrant the products including Li-Ion battery for 12 months from date of purchase subject to proper use conditions stated herein. NiMH batteries carry a warranty of 6 months from date of purchase. All claims should, in the first instance be addressed to the retailer together with proof of purchase.
3. If our product shows a defect, we provide retrospective fulfilment of the contract at our discretion either by repairing the defect or by providing a product free of defects.
4. If such retrospective fulfilment of the contract fails, the customer can at his discretion claim for reduction of the purchase price (reduction) or cancellation of the contract (withdrawal). The customer shall, however, have no right of withdrawal if the defects are of negligible nature.
5. The liability limitations as set forth under Limit of Liability shall be valid if the customer claims for damages.
6. The possibility of claiming for damages is not given, if there is a causal connection between such claims and the fact that:
 - a) our operating instructions or installation instructions have not been followed.
 - b) inappropriate modifications have been made to our product or the product has been inappropriately used.
 - c) if our product is not suitable for the specific application due to unusually high mechanical or thermal stress or if it is over-stressed in any other way.

- d) if our product is not suitable for the installation on the engine due to unusual installation conditions.
- e) if there is natural wear.
- 7. The claim of notification of non-conformance prescribes one year from delivery of the product. The statutory periods of limitation will, however, remain valid in case of injuries of life or body or health, in case of deliberate or grossly negligent breach of duty from our part as well as in case of fraudulent concealment of a defect. The statutory periods are valid also for the
- 8. contribution claims in accordance with § 479 para. 1 BGB (German Civil Code).

Limit of Liability

- The following limitations of liability shall apply:
- Notwithstanding any legal argument, Heinzmann shall not be liable for any damages that did not occur on the supplied product itself.
- This limitation, however, does not apply in case of intent or gross negligence, in case of culpable injury to life, body or health, in case of defects, which have been fraudulently concealed, in case of acceptance of a guarantee or of a procurement risk, in case of violation of essential contract duties, or in case of defects of the delivery item as far as there is a liability according to the law concerning product liability for damages to persons or to property with privately used objects.
- In case of culpable violation of essential contract duties the claim for damages in case of slight negligence is limited to a contract-typical, reasonably foreseeable damage.
- In case of violation of collateral contractual duties, such as e.g. information and advisory duties, the above regulations concerning limitation of liability will correspondingly apply.

13 Disposal

Electrical and electronic equipment may not be disposed of with household rubbish. The user is obliged to dispose of electrical and electronic goods, at the end of their useful life, at suitable collection points or with the supplier. Local regulations apply and should be adhered to.

For suggestions and recommendations on local recycling please contact your local council or supplier.

14 Technical Data

Motor	
Type	RN120
Voltage	36 V
Power	According to configuration 200 ... 250 W S1
Rotation speed when riding on the flat.	According to configuration approx 60 ... 330 rpm
Maximum Torque	According to configuration 35 ... 60 Nm (Nameplate)
Over-temperature protection	Yes
Pitch diameter spoke holes	164 mm
Spoke hole diameter	3.1 ^{+0.1} mm
Offset inside spoke flange	58 ±1 mm
Offset outside spoke flange	66 mm
Dimensions (Ø x B)	178 mm x 127 mm
Weight	3.5 kg
Control Unit	
Voltage	36 V
Current maximum.	According to configuration 20 ... 33 A (Nameplate)
Dimensions (L x B x H)	115 × 100 × 45 mm
Weight	0.7 kg