

Total solder points: 500

Difficulty level:

beginner 1 2 3 4 5 advanced

HIGH-Q
velleman-kit 

HIGH-END CONTROL AMPLIFIER

K8021

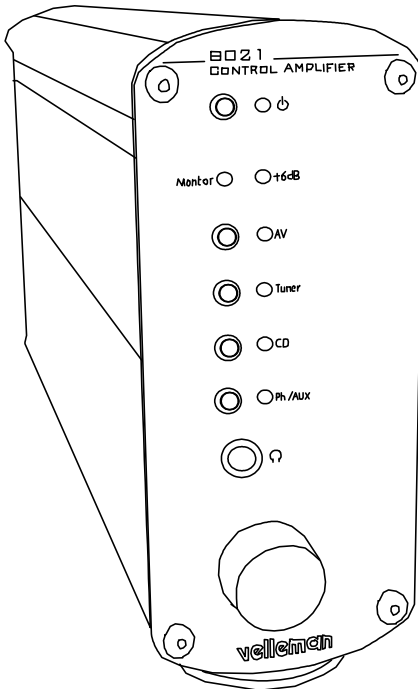

VELLEMAN KIT NV
Legen Heirweg 33
9890 Gavere
Belgium
<http://www.velleman.be>

1. Assembly (Skipping this can lead to troubles !)

Ok, so we have your attention. These hints will help you to make this project successful. Read them carefully.

1.1 Make sure you have the right tools:

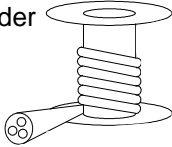
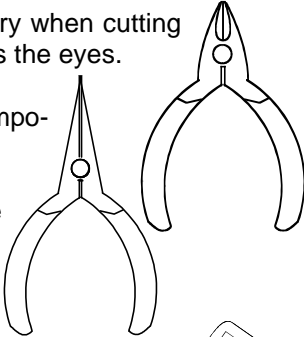
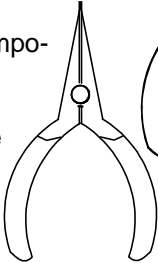
- A good quality soldering iron (25-40W) with a small tip. 
- Wipe it often on a wet sponge or cloth, to keep it clean; then apply solder to the tip, to give it a wet look. This is called 'thinning' and will protect the tip, and enables you to make good connections. When solder rolls off the tip, it needs cleaning. 
- Thin raisin-core solder. Do not use any flux or grease.
- A diagonal cutter to trim excess wires. To avoid injury when cutting excess leads, hold the lead so they cannot fly towards the eyes. 
- Needle nose pliers, for bending leads, or to hold components in place. 
- Small blade and phillips screwdrivers. A basic range is fine.



For some projects, a basic multi-meter is required, or might be handy

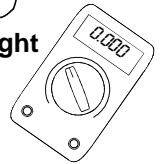

1.2 Assembly Hints :

- ⇒ Make sure the skill level matches your experience, to avoid disappointments.
- ⇒ Follow the instructions carefully. Read and understand the entire step before you perform each operation.
- ⇒ Perform the assembly in the correct order as stated in this manual
- ⇒ Position all parts on the PCB (Printed Circuit Board) as shown on the drawings.
- ⇒ Values on the circuit diagram are subject to changes.
- ⇒ Values in this assembly guide are correct*

- ⇒ Use the check-boxes to mark your progress.
- ⇒ Please read the included information on safety and customer service

* Typographical inaccuracies excluded. Always look for possible last minute manual updates, indicated as 'NOTE' on a separate leaflet.

1.3 Soldering Hints :

1- Mount the component against the PCB surface and carefully solder the leads

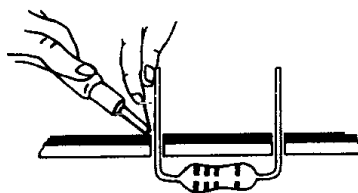

2- Make sure the solder joints are cone-shaped and shiny

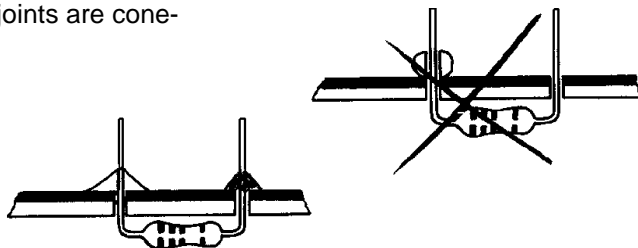

3- Trim excess leads as close as possible to the solder joint

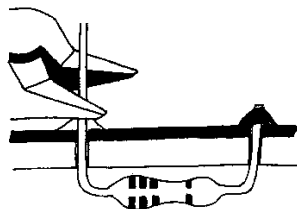

AXIAL COMPONENTS ARE TAPED IN THE CORRECT MOUNTING SEQUENCE !

REMOVE THEM FROM THE TAPE ONE AT A TIME !

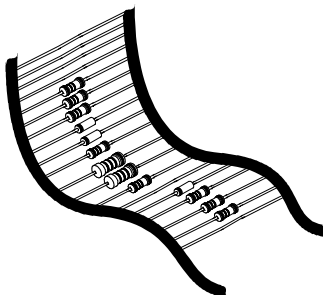

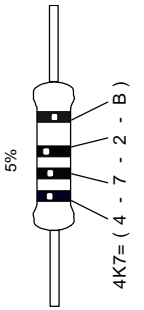
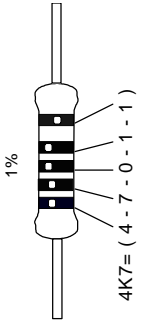
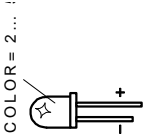

	I	P	E	SF	S	DK	N	D	GB	F	NL
C O D E	CODICE COLORE	CODIGO DE CORES	CODIGO DE COLORE S	VÄRI KOODI	FÄRG SCHEMA	FARVE- KODE	FARGE- KODE	FARB KODE	COLOUR CODE	CODIFI- CATION DES COU-	KLEUR KODE
0	Nero	Preto	Negro	Musta	Svart	Sort	Sort	Schwarz	Black	Noir	Zwart
1	Marrone	Castanho	Marrón	Ruskea	Brun	Brun	Brun	Braun	Brown	Brun	Bruin
2	Rosso	Encar-	Rojo	Punainen	Röd	Rød	Rød	Rot	Red	Rouge	Rood
3	Aran-	Laranja	Naran-	Oranssi	Orange	Orange	Orange	Orange	Orange	Orange	Oranje
4	Giallo	Amarelo	Amarillo	Keltainen	Gul	Gul	Gul	Gelb	Yellow	Jaune	Geel
5	Verde	Verde	Verde	Vihreä	Grön	Grøn	Grønn	Grün	Green	Vert	Groen
6	Blu	Azul	Azul	Sininen	Blå	Blå	Blå	Blau	Blue	Blue	Blauw
7	Viola	Violeta	Morado	Purppura	Lila	Violet	Violet	Violet	Purple	Violet	Paars
8	Grigio	Cinzeno	Gris	Harmaa	Grå	Grå	Grå	Grau	Grey	Gris	Grijs
9	Bianco	Branco	Blanco	Valkoinen	Vit	Hvid	Hvidt	Weiss	White	Blanc	Wit
A	Argento	Prateado	Plata	Hopea	Silver	Sølv	Sølv	Silber	Silver	Argent	Zilver
B	Oro	Dourado	Oro	Kulta	Guld	Guld	Guldi	Gold	Gold	Or	Goud

CONSTRUCTION

The unit consists out of two PCB's, one is the main PCB, P8021B and the other is the left channel input section P8021L.

First we will start with the small P8021L, then we assemble the P8021B.

 **Tip:** The pictures on the packaging can be used as a guideline. However, due to possible changes it is not 100% reliable.

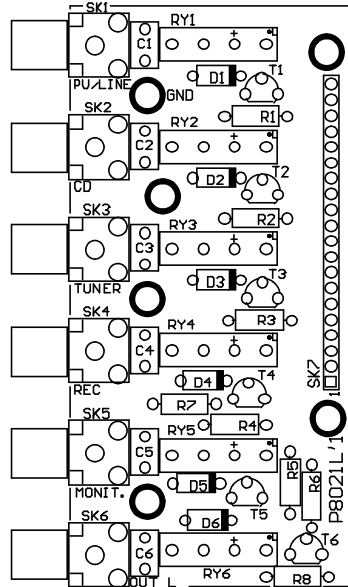

P8021L

1. Diodes (check the polarity)

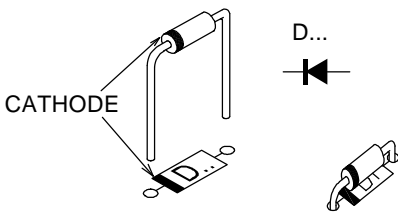

- D1: 1N4148
- D2: 1N4148
- D3: 1N4148
- D4: 1N4148
- D5: 1N4148
- D6: 1N4148

2. Resistors (check the color code)

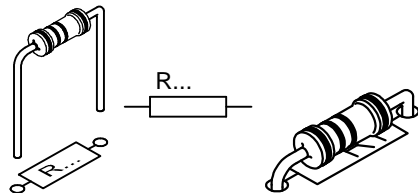

- R1: 10K (1-0-3)
- R2: 10K (1-0-3)
- R3: 10K (1-0-3)
- R4: 10K (1-0-3)
- R5: 10K 1-0-3)
- R6: 10K (1-0-3)
- R7: 1K (1-0-2)
- R8: 330R (3-3-1)

3. Capacitors

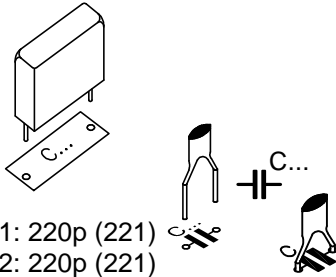

- C1: 220p (221)
- C2: 220p (221)
- C3: 220p (221)
- C4: 220p (221)
- C5: 220p (221)
- C6: 220p (221)

4- Reed relays (check the position of the notch)

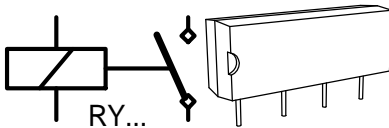

- RY1: VR05051AS or eq.
- RY2: VR05051AS or eq.
- RY3: VR05051AS or eq.
- RY4: VR05051AS or eq.
- RY5: VR05051AS or eq.
- RY6: VR05051AS or eq.

5. transistors

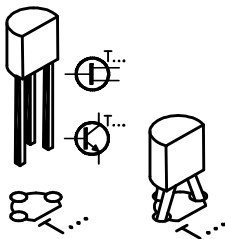

- T1: BC557
- T2: BC557
- T3: BC557
- T4: BC557
- T5: BC557
- T6: BC557

6. RCA connectors.

Mount them straight and against the PCB

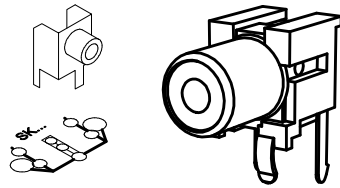

- SK1: MJ-523AG/B **BLACK**
- SK2: MJ-523AG/B **BLACK**
- SK3: MJ-523AG/B **BLACK**
- SK4: MJ-523AG/B **BLACK**
- SK5: MJ-523AG/B **BLACK**
- SK6: MJ-523AG/B **BLACK**

7. Pin connector. Mount it exactly as indicated

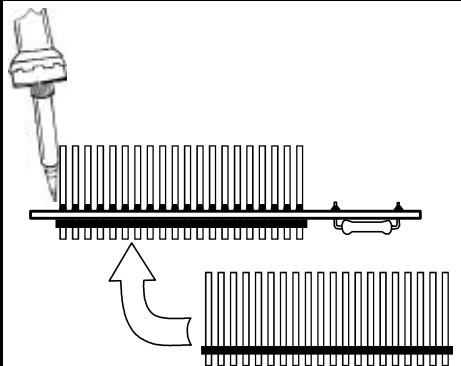

- SK7: HDR20/26

P8021B Assembly

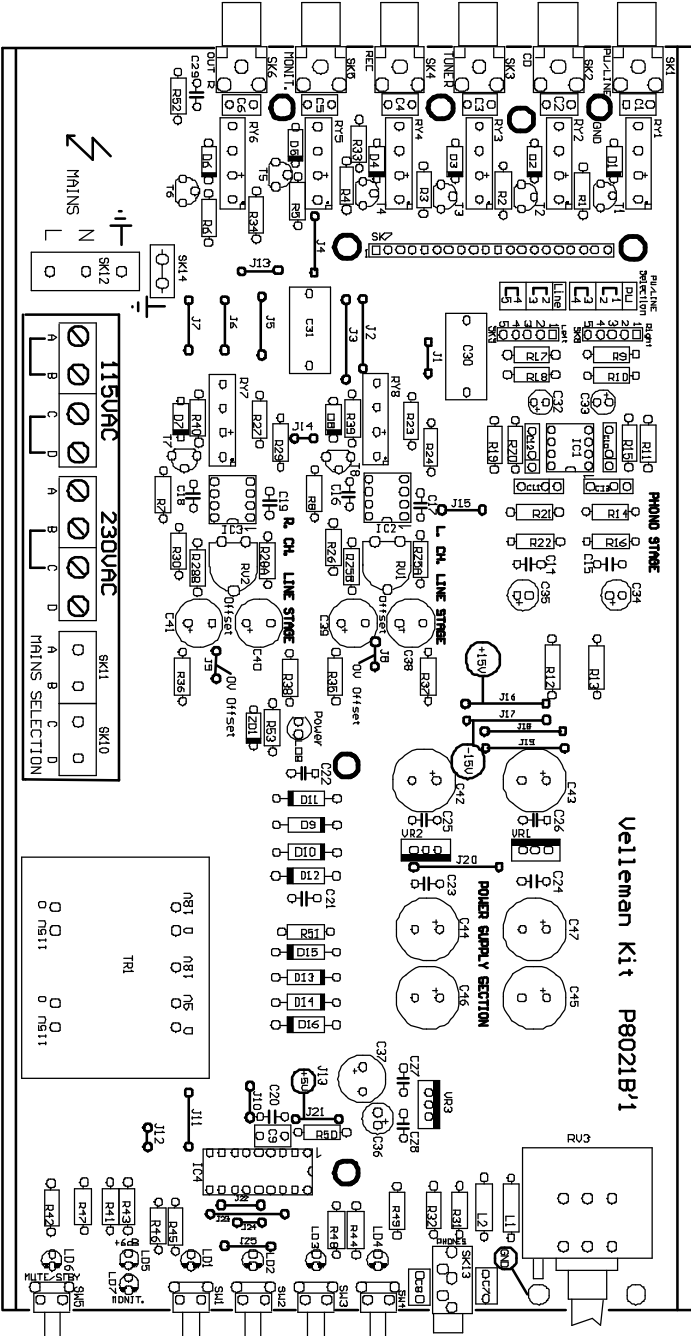

1. Jump wires

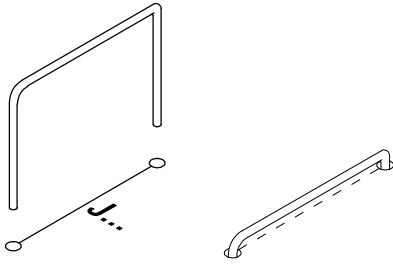

- J1... J25

3. Zener diode (check the polarity)

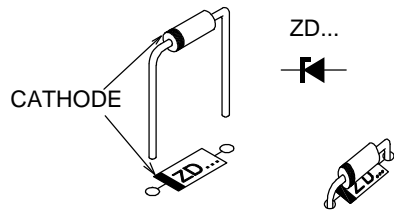

- ZD1: 20V / 0.6W

2. Diodes (check the polarity)

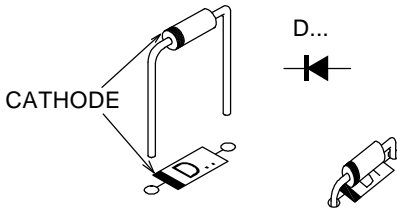

- D1: 1N4148
- D2: 1N4148
- D3: 1N4148
- D4: 1N4148
- D5: 1N4148
- D6: 1N4148
- D7: 1N4148
- D8: 1N4148
- D9: 1N4007
- D10: 1N4007
- D11: 1N4007
- D12: 1N4007
- D13: 1N4007
- D14: 1N4007
- D15: 1N4007
- D16: 1N4007

4. Resistors (check the color code)

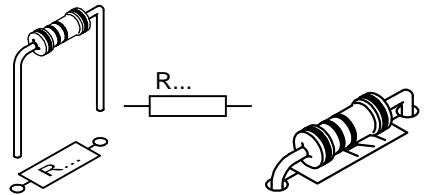

- R1: 10K (1-0-3)
- R2: 10K (1-0-3)
- R3: 10K (1-0-3)
- R4: 10K (1-0-3)
- R5: 10K (1-0-3)
- R6: 10K (1-0-3)
- R7: 10K (1-0-3)
- R8: 10K (1-0-3)
- R9: 47K (4-7-3)
- R10: 470R (4-7-1)
- R11: 620R/1% (6-2-0-0)
- R12: 33R (3-3-0)
- R13: 33R (3-3-0)
- R14: 390K/1% (3-9-0-3)
- R15: 33K/1% (3-3-0-2)
- R16: 1K (1-0-2)
- R17: 47K (4-7-3)
- R18: 470R (4-7-1)
- R19: 620R/1% (6-2-0-0)
- R20: 390K/1% (3-9-0-3)
- R21: 33K/1% (3-3-0-2)

- R22: 1K (1-0-2)
- R23: 560R/1% (5-6-0-0)
- R24: 1K8/1% (1-8-0-1)
- R25A or R25B: 1K5 (1-5-0-1) (*)
- R26: 1K5 (1-5-2)
- R27: 560R/1% (5-6-0-0)
- R28A or R28B: 1K5 (1-5-2) (*)

*** The position of R25 and R28 depends on the supplied IC for IC2 and IC3:**

Mount R25B and R28B if type OPA134 is supplied.

Mount R25A and R28A. If types OPA604 or TLE2071 are supplied.

- R29: 1K8/1% (1-8-0-1)
- R30: 1K5 (1-5-2)
- R31: 56R (5-6-0)
- R32: 56R (5-6-0)
- R33: 1K (1-0-2)
- R34: 330R (3-3-1)
- R35: 1R (1-0-0)
- R36: 1R (1-0-0)
- R37: 1R (1-0-0)
- R38: 1R (1-0-0)
- R39: 1K/1% (1-0-0-1)
- R40: 1K/1% (1-0-0-1)
- R41: 1K (1-0-2)
- R42: 1K (1-0-2)
- R43: 1K (1-0-2)
- R44: 1K (1-0-2)
- R45: 10K (1-0-3)
- R46: 10K (1-0-3)
- R47: 10K (1-0-3)
- R48: 10K (1-0-3)
- R49: 10K (1-0-3)
- R50: 4K7 (4-7-2)
- R51: 1R (1-0-0)
- R52: 470R (4-7-1)
- R53: 1K5 (1-5-2)

5. Choke

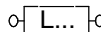

- L1: 1uH (1-0)
- L2: 1uH (1-0)

6. IC sockets

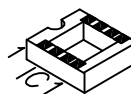
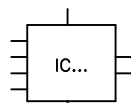
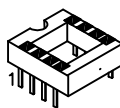

- IC1: 8P
- IC2: 8P
- IC3: 8P
- IC4: 18P

7. Female header

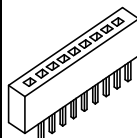

SK..

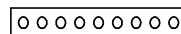

- SK7: 20P (type 96120205)

8. Capacitors

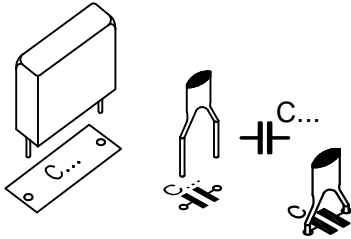

- C1: 220p (221)
- C2: 220p (221)
- C3: 220p (221)
- C4: 220p (221)
- C5: 220p (221)
- C6: 220p (221)
- C7: 220p (221)
- C8: 220p (221)
- C9: 220p (221)
- C10: 2n2 (222, 2200)
- C11: 2n2 (222, 2200)
- C12: 8n2 (822, 8200)
- C13: 8n2 (822, 8200)
- C14: 100n (104, 0.1, u1)
- C15: 100n (104, 0.1, u1)
- C16: 100n (104, 0.1, u1)
- C17: 100n (104, 0.1, u1)
- C18: 100n (104, 0.1, u1)
- C19: 100n (104, 0.1, u1)
- C20: 100n (104, 0.1, u1)
- C21: 100n (104, 0.1, u1)
- C22: 100n (104, 0.1, u1)
- C23: 100n (104, 0.1, u1)
- C24: 100n (104, 0.1, u1)
- C25: 100n (104, 0.1, u1)
- C26: 100n (104, 0.1, u1)
- C27: 100n (104, 0.1, u1)
- C28: 100n (104, 0.1, u1)
- C29: 100n (104, 0.1, u1)
- C30: 2.2uF
- C31: 2.2uF

9. Reed relays (check the position of the notch)

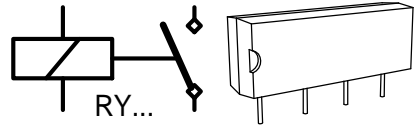

- RY1: VR05051AS or eq.
- RY2: VR05051AS or eq.
- RY3: VR05051AS or eq.
- RY4: VR05051AS or eq.
- RY5: VR05051AS or eq.
- RY6: VR05051AS or eq.
- RY7: VR05051AS or eq.
- RY8: VR05051AS or eq.

10. Pin header connector, cut at the indicated 5 pins

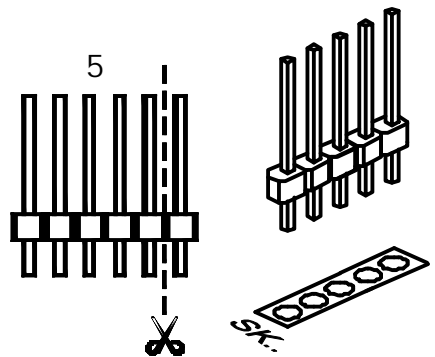

- SK8: 5P
- SK9: 5P

11. transistors

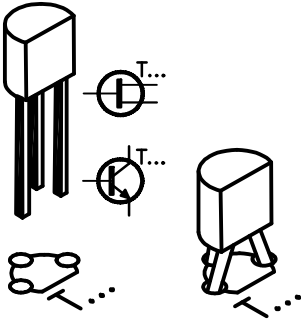

- T1: BC557
- T2: BC557
- T3: BC557
- T4: BC557
- T5: BC557
- T6: BC557
- T7: BC557
- T8: BC557

13. Push button

Mount them straight against the PCB surface !

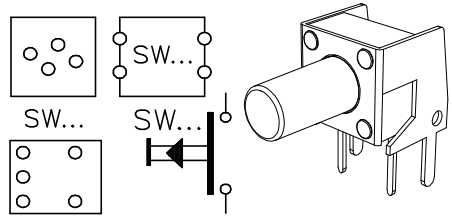

- SW1: TS-04PV
- SW2: TS-04PV
- SW3: TS-04PV
- SW4: TS-04PV
- SW5: TS-04PV

Remark: The metal part of these buttons are used as jump wire.

Be sure not to test or use the unit without soldering these push buttons.

12. Trim potentiometer

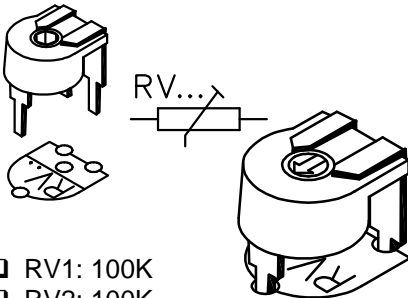

- RV1: 100K
- RV2: 100K

14. Phone jack.

Mount him straight against the PCB surface !

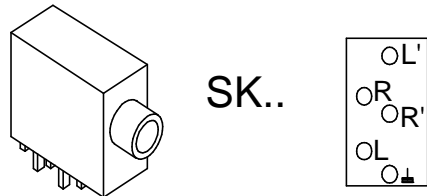

- SK13: JCF3.5 (3.5mm jack)

15. RCA connectors.
Mount them straight and against the PCB

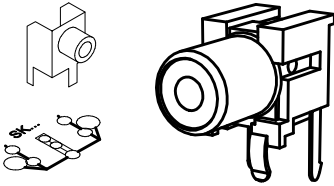

- SK1: MJ-523AG/R RED
- SK2: MJ-523AG/R RED
- SK3: MJ-523AG/R RED
- SK4: MJ-523AG/R RED
- SK5: MJ-523AG/R RED
- SK6: MJ-523AG/R RED

17. Voltage regulator.
The back side corresponds to the thick line.

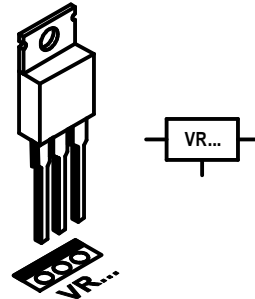

- VR1 UA7815
- VR2 UA7915
- VR3 UA7805

16. Electrolytic capacitors.
Check the polarity !

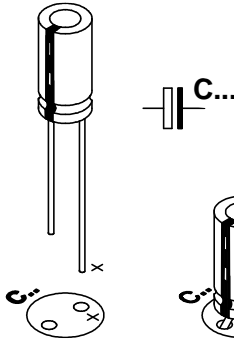

- C32: 47 μ
- C33: 47 μ
- C34: 100 μ
- C35: 100 μ
- C36: 100 μ
- C37: 470 μ
- C38: 470 μ
- C39: 470 μ
- C40: 470 μ
- C41: 470 μ
- C42: 1000 μ
- C43: 1000 μ
- C44: 1000 μ
- C45: 1000 μ
- C46: 1000 μ
- C47: 1000 μ

18. Transformer.

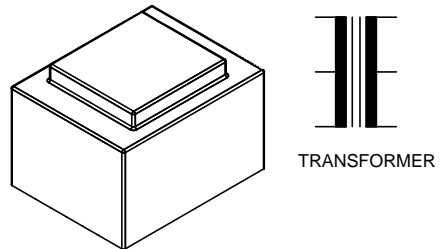

- TR1: TR8021, 9V-2x18V/ 6VA

19. Volume potentiometer.

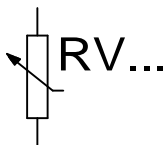

- RV3: STRK27103 (2x50K ALPS)

CAUTION:

This is a high quality potentiometer, handle it with care. Follow the mounting instructions exactly and in order!

1. Mount the support bracket onto the potentiometer. Tighten the nut carefully.

2. Mount the potentiometer onto the PCB, using two 6mm (0.23") screws and M3 nut.

Only slightly tighten the nuts!
Do not solder the potentiometer connections yet!

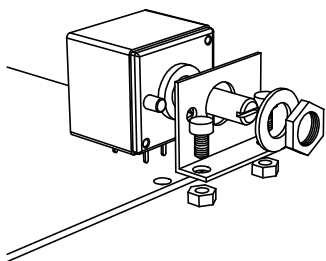

20. Mains voltage selection

Use a piece of isolated brown wire to select the mains (outlet) voltage, as indicated on the PC board.

- For 115Vac (100 to 120Vac)**

A jumper between A-B, and a jumper between C-D.



- For 230Vac (220 to 240Vac)**

A jumper between B-C.

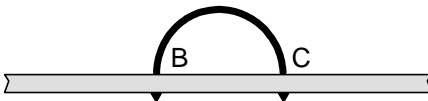

Using a black marker, erase the not used voltage at the back of the unit.

21. Mains voltage connection preparation

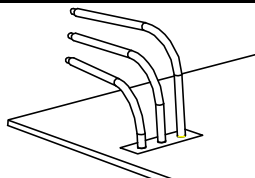

- Connect a 10cm blue wire to the point **N** of SK12.
- Connect a 10cm brown wire to the point **L** of SK12.
- Connect a 10cm yellow/green wire to the **earth** point of SK12.

Later these connection will be soldered to the mains connector.

22. Mounting the LED's. Check the polarity ! Short lead = Cathode or — !

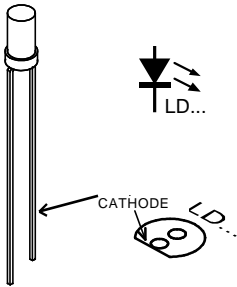

CAUTION:
After bending the leads the long appearing lead will be the cathode!

First: Bend the leads exactly like the drawing.

Next: Solder **one** lead, and check the position, if necessary correct by heating the soldering.

Last: Solder the second connection.

IMPORTANT
Mount these LED's exactly like in the drawing, otherwise some LED's will not fit correctly in the front panel. Please also use the front panel as a positioning reference.

LD7 L-424YDT

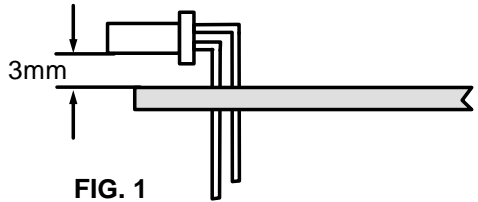
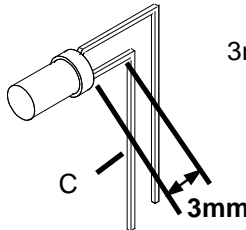

- LD1 L-424YDT
- LD2 L-424YDT
- LD3 L-424YDT
- LD4 L-424YDT
- LD5 L-424YDT
- LD6 L-424YDT

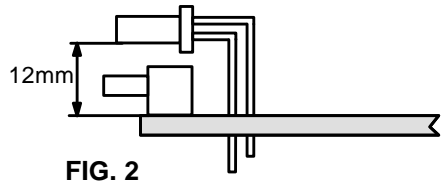
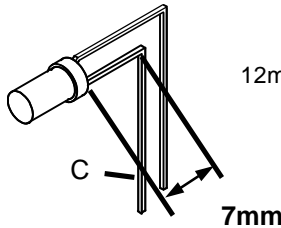

LD8 L-424YDT

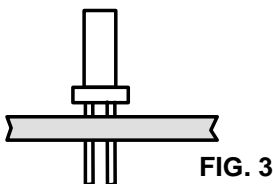

23. Mounting the sub PCB support

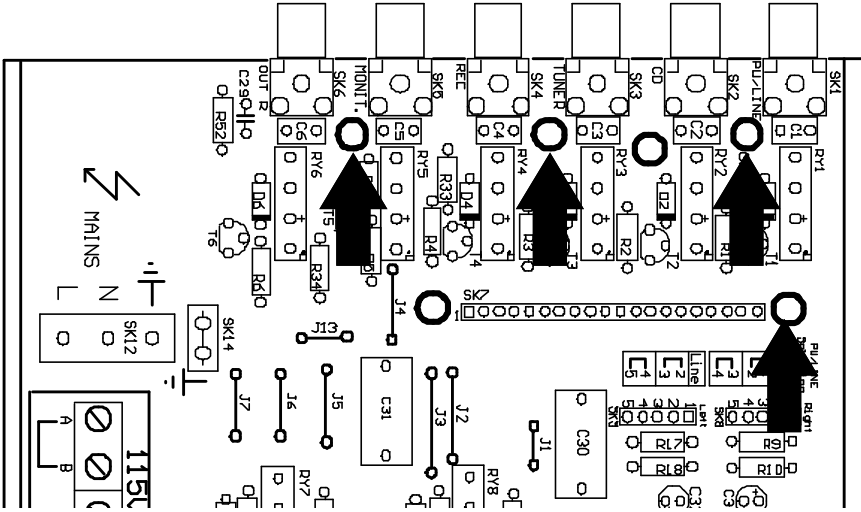

- Mount four 2cm (0.8") M3 spacers at the indicated positions using four 6mm (0.23") M3 screws.

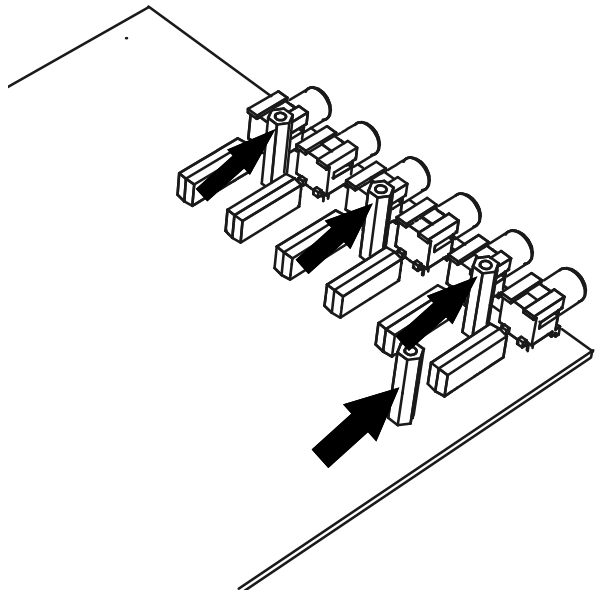

24. Enclosure preparation

- ❑ Cut the thread in the holes for the enclosure feet in one of the aluminum profiles, using the supplied special M4 screw as a tap.

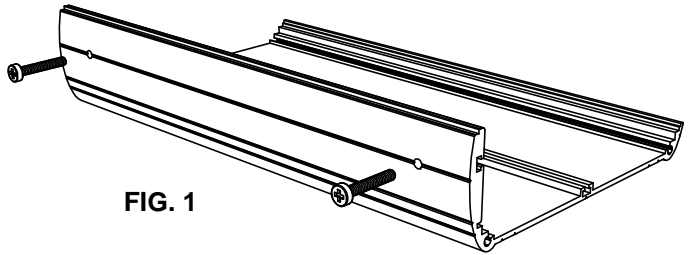

FIG. 1

- ❑ Mount the Feet on the aluminum profile, using two M4 hexagonal Allen screws. Use the supplied Allen wrench. It is advisable to stick the protection adhesive onto the feet.

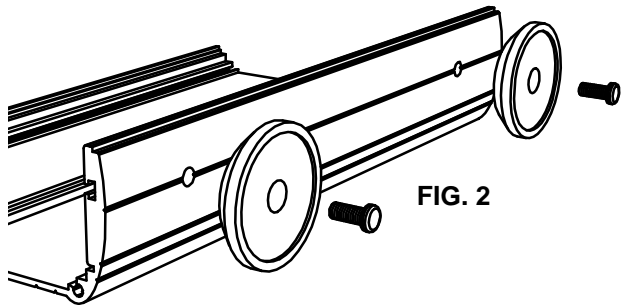

FIG. 2

- ❑ Cut the thread in the front and back of the aluminum profiles, using the supplied special M4 screw (4 holes per piece)

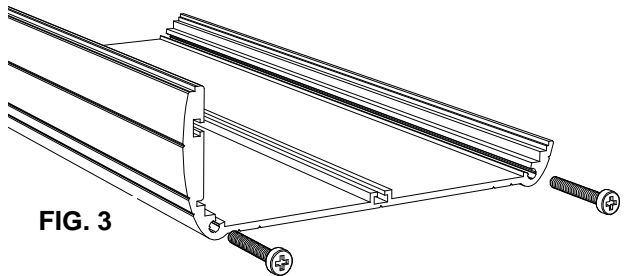

FIG. 3

- ❑ Cut the thread in the back panel phono ground screw position, using the supplied special M3 screw.

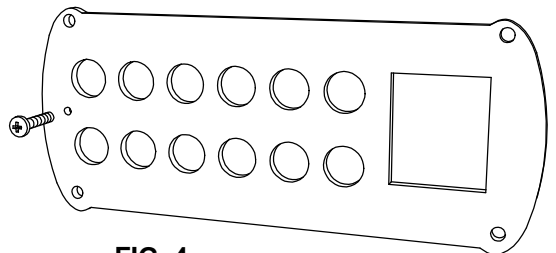

FIG. 4

- ❑ Position the main PCB in the aluminum profile that is prepared with the feet. The potentiometer must be at the same side of the feet.

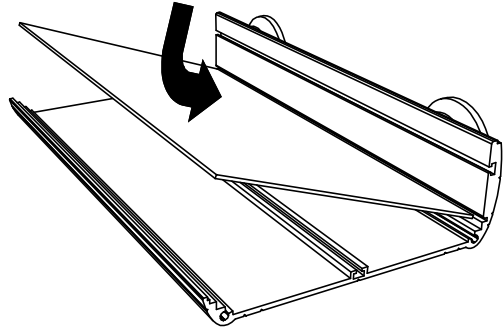
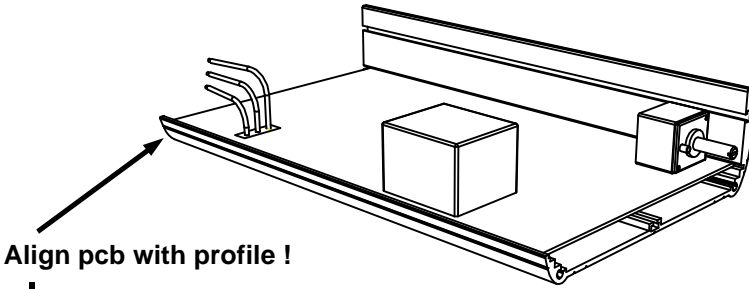
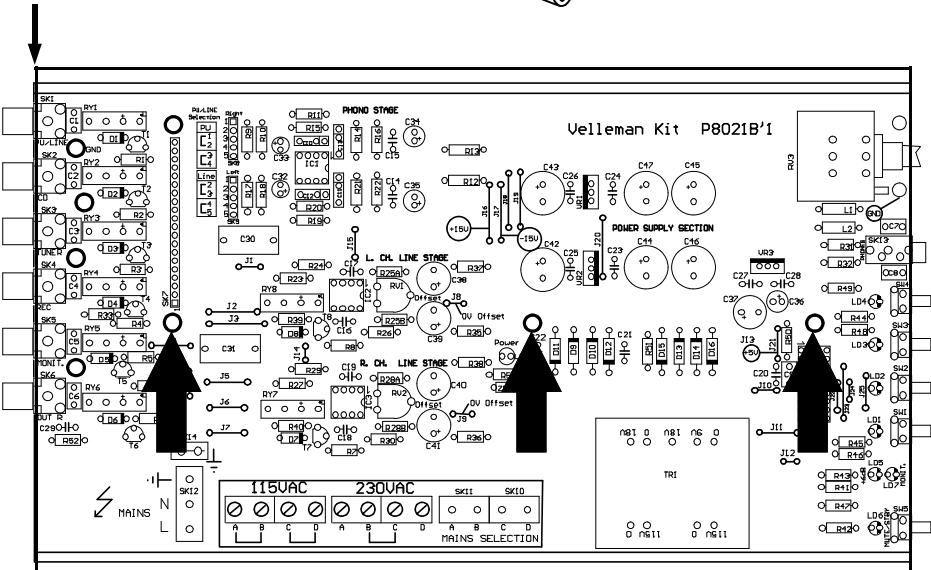

FIG. 5



Align pcb with profile !



- ❑ Mark the center position of the three fixation holes on the aluminum.

- ❑ Remove the pcb and use a knife or a screwdriver to scratch the paint from the aluminum fixation, from the hole closest to the back end. This fixation will be used later to connect the ground and earth.

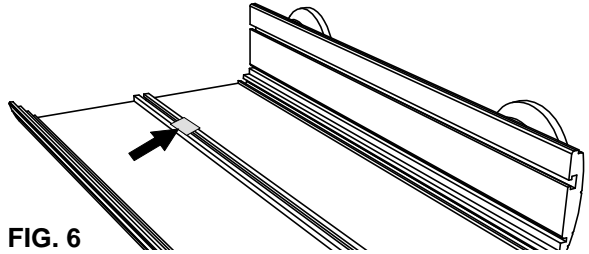

FIG. 6

- ❑ Mount the 3, 5mm (0.14") spacers like in the drawing. Using three hexagonal screws and a washer. Do not tighten the spacers yet.

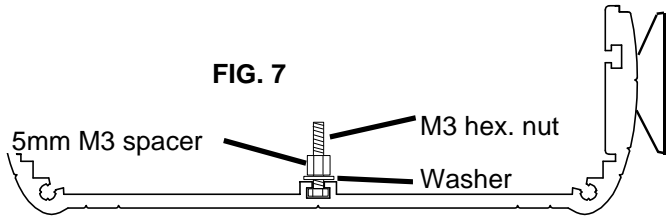

FIG. 7

- ❑ Position the PCB in the enclosure and check if the position of the spacers is correct, if so, remove the PCB and tighten the spacers.

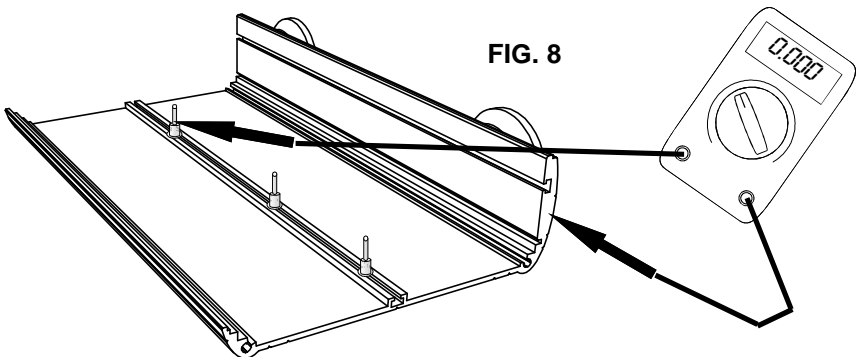
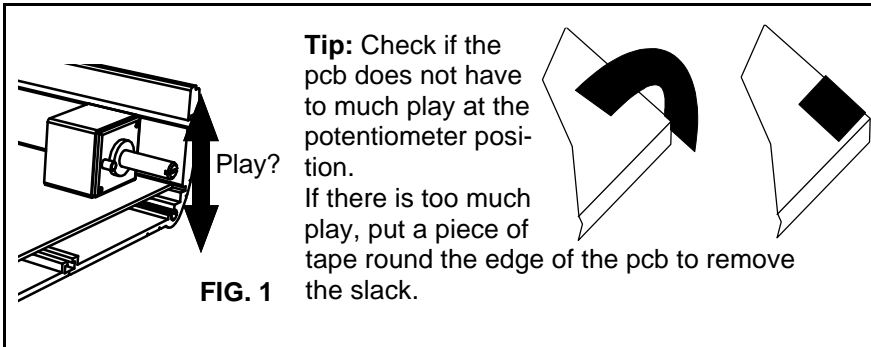

FIG. 8

- ❑ Using an ohmmeter, measure between the edge of the aluminum profile and the back spacer, if there is a good electric contact (0 ohm). If not, repeat the above step to remove the paint under the spacer.

25. Potentiometer assembly and final PCB mount

- ❑ Mount the PCB into the enclosure like before.



- ❑ Fix the pcb using a 5mm spacers next to C36.

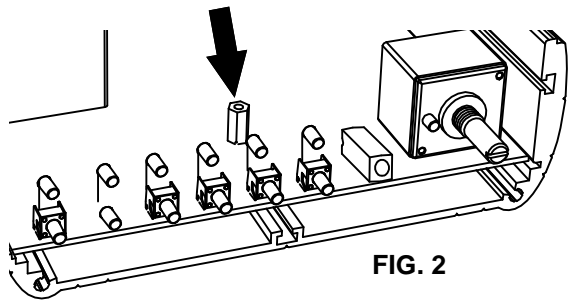

- ❑ Mount the knob onto the potentiometer. (check the notch position)

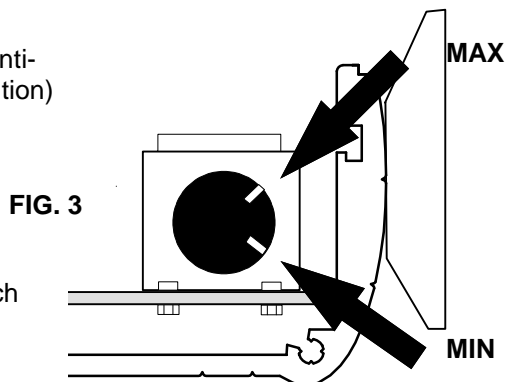

- ☞ Use the supplied Allen wrench

- ❑ Now carefully mount the front panel, using two M4 Allen screws. Check the position of the LED's.
- ❑ Check if the potentiometer turns smoothly without touching the front panel, otherwise correct his position or the position of the front panel.
- ❑ Check if the phones connector (metal part) does not touch the front panel.

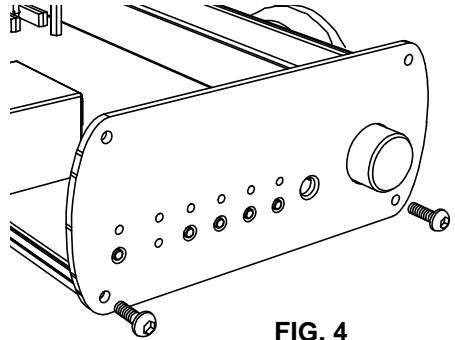

FIG. 4

☞ Use the supplied Allen wrench

- ❑ Remove the front panel and fix the nuts of the potentiometer bracket.
- ❑ Remove the PCB from the enclosure and solder the potentiometer connections.
- ❑ Again mount the pcb into the enclosure.

- ❑ Fix the pcb using a 2cm (0.8") spacer at the position next to SK7 and use 5mm spacers to fix the other two positions. Measure, using an ohm meter (or continuity beeper) if the 2cm spacer is electrically connected to the ground wire (yellow green wire). If not, recheck if the paint of the aluminum is correctly removed.

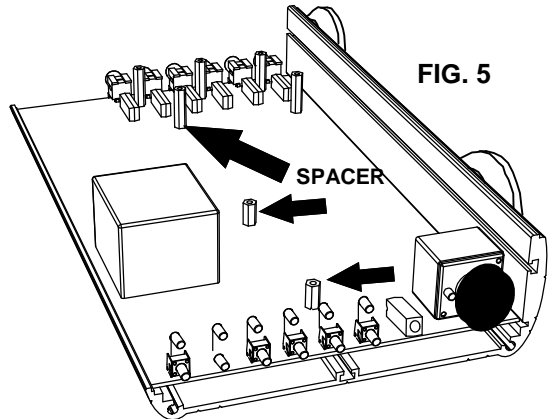

FIG. 5

- ❑ Mount the left channel PCB onto the spacers, check that the connector is correctly inserted. Fix the PCB using five 6mm M3 screws.

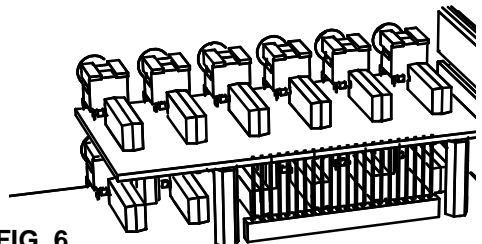

FIG. 6

26. Final assembly and connection

- ❑ Mount (insert) the mains connector onto the rear panel. Insert a 250mA fuse into the connector (there is also room for a spare fuse).
- ❑ Mount the rear panel onto the enclosure, using two M4 Allen screws.

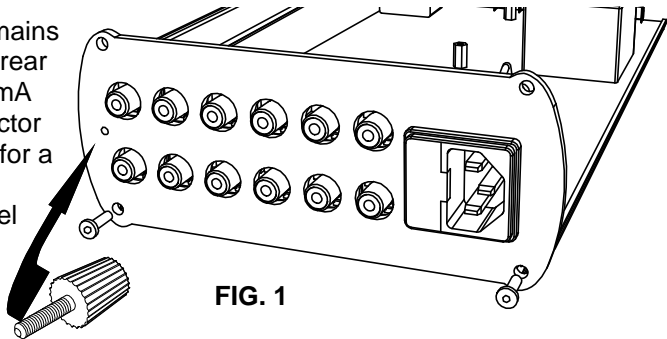

FIG. 1

- ❑ Mount the plastic phono ground screw onto the back panel.
- ❑ Connect the mains wires to the mains connector, Blue= Neutral, Brown= Live, and green/yellow= Earth. Use a piece of 1.5cm (0.6") shrink tube to isolate each connection.

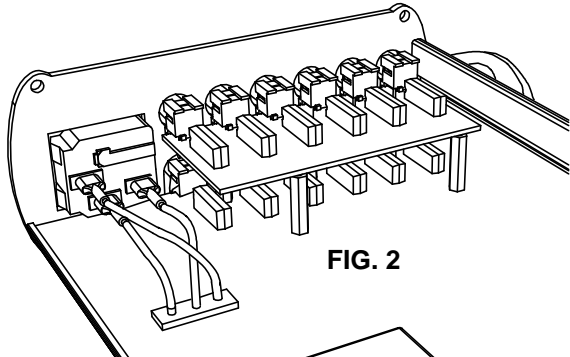

FIG. 2

- ❑ Mount the front panel onto the front, using two M4 Allen screws.

- ☞ Check the position of the LED's and check if all buttons are working correctly.

It could be that paint rest over in the holes, is preventing the buttons from smooth operation.

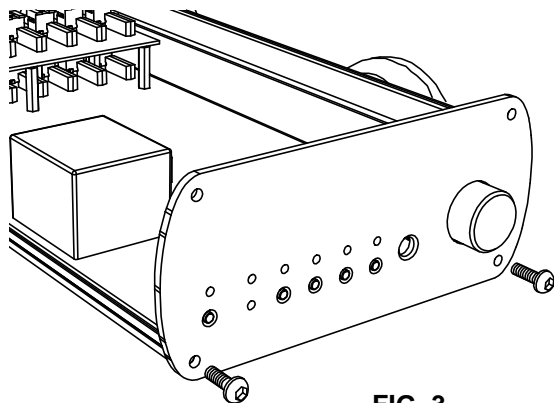

FIG. 3

27. Test and adjustment

Connect the mains AC voltage to the mains connector. Check if the power LED (in the center of the PCB) is lit. This means that the +15V and -15V are correct.



CAUTION: Some points on the PCB are connected to the dangerous mains voltage.

Disconnect the mains plug.

Now insert the IC's into their sockets:

- IC1 NE5532
- IC2 TLE2071 / OPA134 / OPA604
- IC3 TLE2071 / OPA134 / OPA604
- IC4 VK8021 / PIC16C54RC

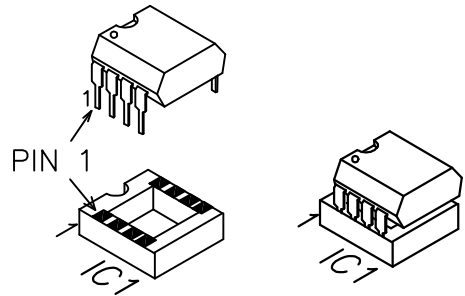

Offset adjustment:

It is important that the output of the amplifiers are free of DC voltage therefore the offset voltage needs adjustment:

1. Connect the unit to the mains.
2. Push the CD input selector button, the corresponding LED should lit.
3. Push and hold the CD input selector button, the +6dB LED should lit.
4. Use a multimeter and set it to the lowest voltage range (2Vdc or lower).
5. Measure between GND (the metal bracket of the potentiometer can be used) and J8 (Left channel offset adjustment).
6. Adjust the offset trimmer (next to IC2) until the meter indicates around 0V
7. Measure at point J9 (Right channel offset adjustment).
8. Adjust the offset trimmer (next to IC3) until the meter indicates around 0V

Check the user manual to test all functions and operation of the unit, then the cover aluminum can be mounted.

Please note that the user manual is also used for the ready assembled version. Some remarks may not be related to the kit version.

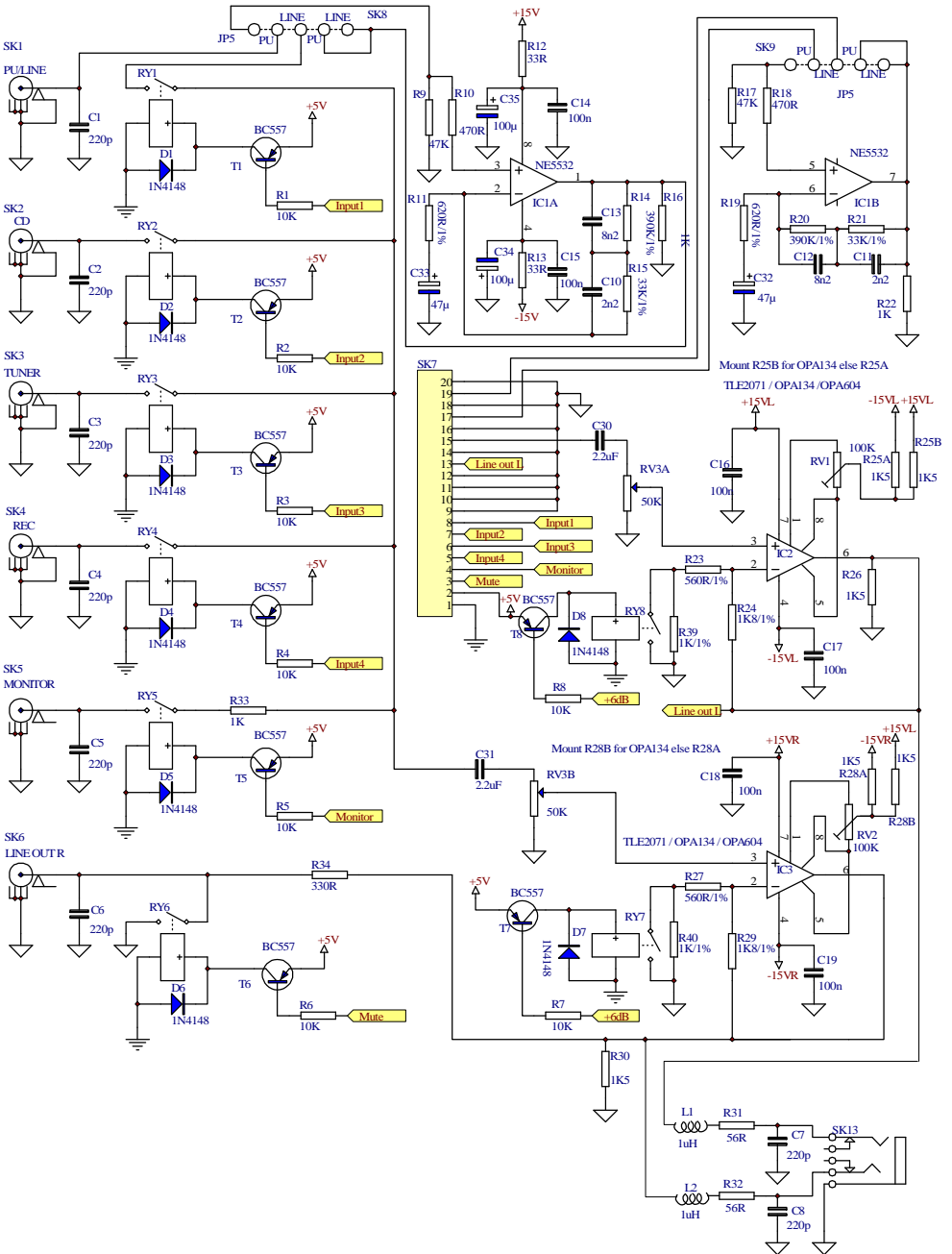

RIGHT INPUT / OUTPUT SECTION
AMPLIFIER SECTION

© Velleman Kit

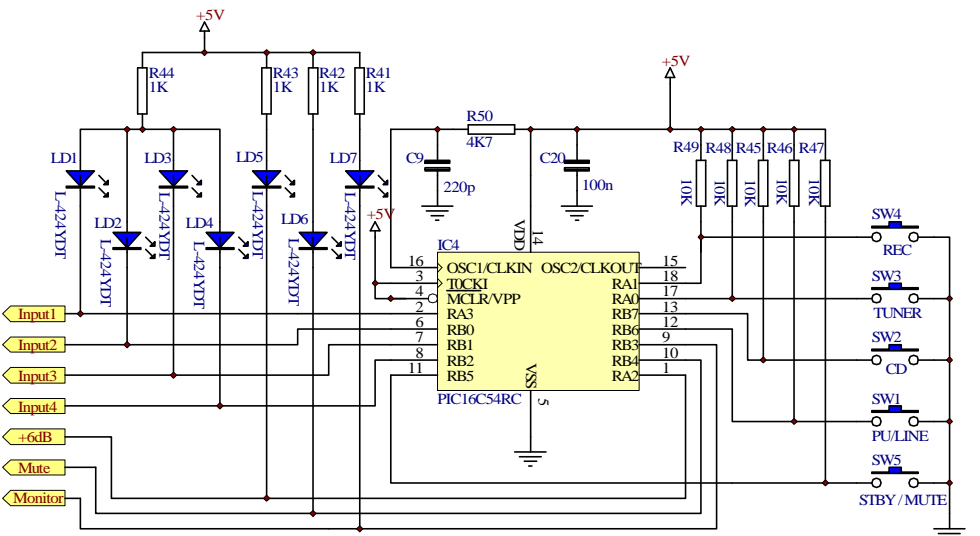
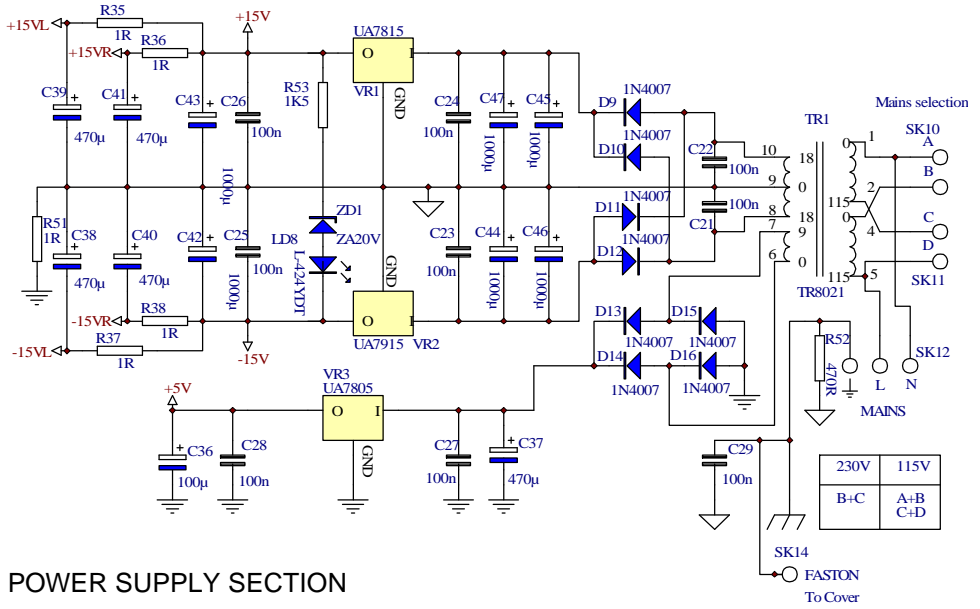

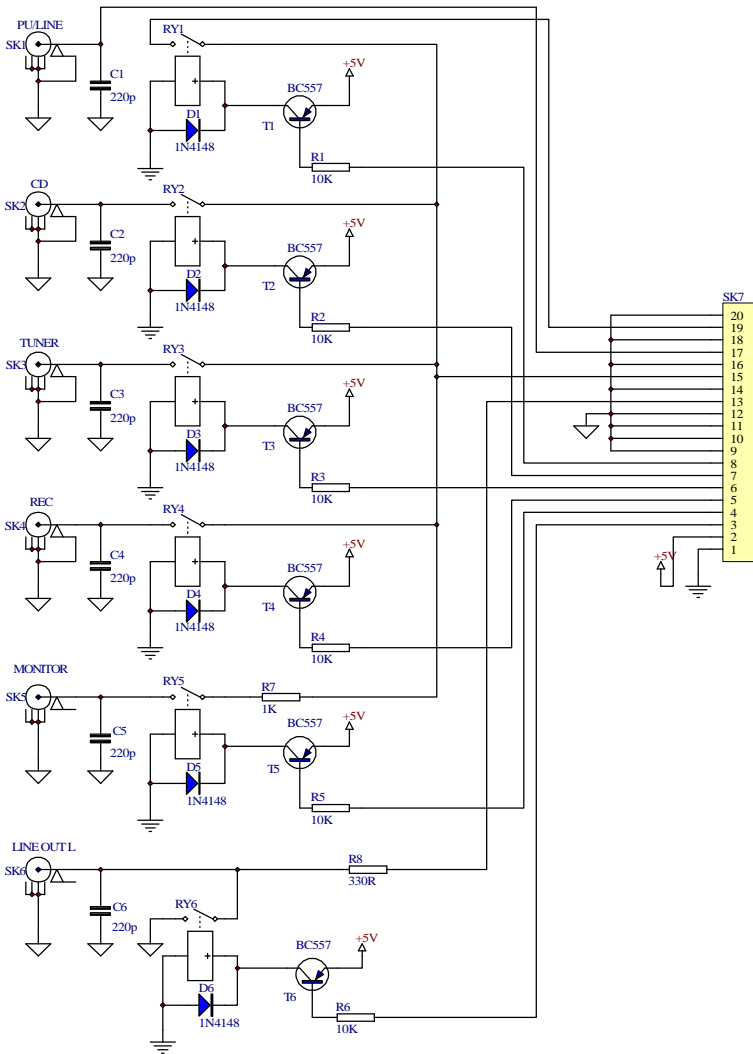

LEFT INPUT SECTION

NOTES:

VELLEMAN KIT NV
Legen Heirweg 33
9890 Gavere
Belgium Europe
Info ? : <http://www.velleman.be>
Questions ? : support@velleman.be

Modifications and typographical errors reserved
© Velleman Kit nv
H8021IP - 2000 - ED1