

# Preface

## Copyright

This publication, including all photographs, illustrations and software, is protected under international copyright laws, with all rights reserved. Neither this manual, nor any of the material contained herein, may be reproduced without written consent of the author.

Version 6.0

## Disclaimer

The information in this document is subject to change without notice. The manufacturer makes no representations or warranties with respect to the contents hereof and specifically disclaims any implied warranties of merchantability or fitness for any particular purpose. The manufacturer reserves the right to revise this publication and to make changes from time to time in the content hereof without obligation of the manufacturer to notify any person of such revision or changes.

## Trademark Recognition

Microsoft, MS-DOS and Windows are registered trademarks of Microsoft Corp.

MMX, Pentium, Pentium-II, Pentium-III, Celeron are registered trademarks of Intel Corporation.

Other product names used in this manual are the properties of their respective owners and are acknowledged.

## Federal Communications Commission (FCC)

This equipment has been tested and found to comply with the limits for a Class B digital device, pursuant to Part 15 of the FCC Rules. These limits are designed to provide reasonable protection against harmful interference in a residential installation. This equipment generates, uses, and can radiate radio frequency energy and, if not installed and used in accordance with the instructions, may cause harmful interference to radio communications. However, there is no guarantee that interference will not occur in a particular installation. If this equipment does cause harmful interference to radio or television reception, which can be determined by turning the equipment off and on, the user is encouraged to try to correct the interference by one or more of the following measures:

- Reorient or relocate the receiving antenna.
- Increase the separation between the equipment and the receiver.
- Connect the equipment onto an outlet on a circuit different from that to which the receiver is connected.
- Consult the dealer or an experienced radio/TV technician for help.

Shielded interconnect cables and a shielded AC power cable must be employed with this equipment to ensure compliance with the pertinent RF emission limits governing this device. Changes or modifications not expressly approved by the system's manufacturer could void the user's authority to operate the equipment.

## Declaration of Conformity

This device complies with part 15 of the FCC rules. Operation is subject to the following conditions:

- This device may not cause harmful interference, and
- This device must accept any interference received, including interference that may cause undesired operation.

## Canadian Department of Communications

This class B digital apparatus meets all requirements of the Canadian Interference-causing Equipment Regulations.

Cet appareil numérique de la classe B respecte toutes les exigences du Règlement sur le matériel brouilleur du Canada.

## About the Manual

The manual consists of the following:

|   |   |
|---|---|
| <b>Chapter 1</b><br><b>Introducing the Motherboard</b>    | Describes features of the motherboard, and provides a shipping checklist.<br>Go to ⇒ page 1 |
| <b>Chapter 2</b><br><b>Installing the Motherboard</b>     | Describes installation of motherboard components.<br>Go to ⇒ page 6                         |
| <b>Chapter 3</b><br><b>Using BIOS</b>                     | Provides information on using the BIOS Setup Utility.<br>Go to ⇒ page 23                    |
| <b>Chapter 4</b><br><b>Using the Motherboard Software</b> | Describes the motherboard software.<br>Go to ⇒ page 44                                      |

---

## TABLE OF CONTENTS

---

|   |           |
|---|-----------|
| Preface   | i         |
| <b>CHAPTER 1</b>                                  | <b>1</b>  |
| <b>Introducing the Motherboard</b>                | <b>1</b>  |
| <i>Introduction</i> .....                         | 1         |
| <i>Features</i> .....                             | 2         |
| <i>Choosing a Computer Case</i> .....             | 3         |
| <i>Motherboard Components</i> .....               | 4         |
| <b>CHAPTER 2</b>                                  | <b>6</b>  |
| <b>Installing the Motherboard</b>                 | <b>6</b>  |
| <i>Safety Precautions</i> .....                   | 6         |
| <i>Quick Guide</i> .....                          | 6         |
| <i>Installing the Motherboard in a Case</i> ..... | 7         |
| <i>Checking Jumper Settings</i> .....             | 7         |
| Setting Jumpers.....                              | 7         |
| Checking Jumper Settings.....                     | 8         |
| Jumper Settings.....                              | 8         |
| <i>Connecting Case Components</i> .....           | 9         |
| Front Panel Connector.....                        | 11        |
| <i>Installing Hardware</i> .....                  | 12        |
| Installing the Processor.....                     | 12        |
| Installing Memory Modules.....                    | 15        |
| Installing a Hard Disk Drive/CD-ROM.....          | 16        |
| Installing a Floppy Diskette Drive.....           | 17        |
| Installing Add-on Cards.....                      | 18        |
| Connecting Optional Devices.....                  | 20        |
| <i>Connecting I/O Devices</i> .....               | 22        |
| <b>CHAPTER 3</b>                                  | <b>23</b> |
| <b>Using BIOS</b>                                 | <b>23</b> |
| <i>About the Setup Utility</i> .....              | 23        |
| The Standard Configuration.....                   | 23        |
| Entering the Setup Utility.....                   | 24        |
| Updating the BIOS.....                            | 24        |
| <i>Using BIOS</i> .....                           | 25        |
| Standard CMOS Features.....                       | 26        |
| Advanced BIOS Setup Option.....                   | 28        |
| Advanced Chipset Features Option.....             | 31        |
| Integrated Peripherals Option.....                | 33        |
| Power Management Setup Option.....                | 36        |
| PNP/PCI Configuration Option.....                 | 39        |
| PC Health Status Option.....                      | 40        |

|                                      |    |
|--------------------------------------|----|
| Frequency/Voltage Control.....       | 41 |
| Load Fail-Safe Defaults Option ..... | 42 |
| Load Optimized Defaults Option ..... | 42 |
| Set Supervisor/User Password.....    | 42 |
| Save & Exit Setup Option .....       | 43 |
| Exit Without Saving.....             | 43 |

**CHAPTER 4** **44**

|  |           |
|--|-----------|
| <b>Using the Motherboard Software</b> .....              | <b>44</b> |
| <i>About the Software CD-ROM</i> .....                   | 44        |
| <i>Auto-installing under Windows 98/ME/2000/XP</i> ..... | 44        |
| Running Setup .....                                      | 45        |
| <i>Manual Installation</i> .....                         | 47        |
| <i>Utility Software Reference</i> .....                  | 47        |

*Chapter 1*

## Introducing the Motherboard

---

### **Introduction**

Congratulations on purchasing this motherboard. This motherboard is a Micro-ATX motherboard that uses a 4-layer printed circuit board and measures 244 mm x 200 mm. The motherboard is design to support the mPGA Socket 478 Intel P4 Willamette/Northwood/Prescott processors and the new Intel 845GL/845GV chipset.

With system bus speeds up to 533/400 MHz (845GV only), this motherboard represents the most powerful desktop and cost-effective integrated solution available today.

The motherboard has an advanced full set of I/O ports, such as dual channel IDE interfaces, a floppy controller, a high-speed serial port, a VGA port, an EPP/ECP capable bi-directional parallel port connector, four USB (Universal Serial Bus) connectors, a PS/2 keyboard connector, mouse connector and audio jacks for microphone, line-in, line-out. One ADD slot, three PCI local bus slots and one communication and networking riser (CNR) slot provide expandability for add-on peripheral cards.

In addition to its excellent performance and stability, the motherboard is highly suited for Internet and rich multimedia applications, including streaming video download and are ideal for workstations and high-end home use.

## Features

| <b>Processor</b>          | <p>The motherboard uses a micro PGA 478-pin socket that has the following features:</p> <ul style="list-style-type: none"> <li>Accommodates Intel/P4 Willamette/Northwood/Prescott 478-pins CPU</li> </ul> <table border="1" data-bbox="626 562 1172 747"> <thead> <tr> <th data-bbox="626 562 721 590">NB</th> <th data-bbox="721 562 873 590">SB</th> <th data-bbox="873 562 1172 590">FSB</th> </tr> </thead> <tbody> <tr> <td data-bbox="626 590 721 667">845GL</td> <td data-bbox="721 590 873 667">82801(ICH4)</td> <td data-bbox="873 590 1172 667">Supports 400 MHz front side bus (FSB) with memory speed of 266 MHz</td> </tr> <tr> <td data-bbox="626 667 721 747">845GV</td> <td data-bbox="721 667 873 747">82801(ICH4)</td> <td data-bbox="873 667 1172 747">Supports 533/400 MHz front side bus (FSB) with memory speed of 333/266 MHz</td> </tr> </tbody> </table>  | NB   | SB | FSB | 845GL | 82801(ICH4) | Supports 400 MHz front side bus (FSB) with memory speed of 266 MHz | 845GV | 82801(ICH4) | Supports 533/400 MHz front side bus (FSB) with memory speed of 333/266 MHz |
|---------------------------|---|--|----|-----|-------|-------------|--|-------|-------------|--|
| NB                        | SB  | FSB  |    |     |       |             |  |       |             |  |
| 845GL                     | 82801(ICH4)   | Supports 400 MHz front side bus (FSB) with memory speed of 266 MHz         |    |     |       |             |  |       |             |  |
| 845GV                     | 82801(ICH4)   | Supports 533/400 MHz front side bus (FSB) with memory speed of 333/266 MHz |    |     |       |             |  |       |             |  |
| <b>Chipset</b>            | <p>Intel's innovative 845GL/845GV (GMCH) and 82801DB (ICH4) chipsets are based on an innovative and scalable architecture with proven reliability and performance. A few of the advanced features of the chipsets are:</p> <ul style="list-style-type: none"> <li>Supports system bus Dynamic Bus Inversion (DBI).</li> <li>Supports 266/333 MHz DDR SDRAM devices</li> <li>AGTL+ Host Bus with Integrated Termination supporting 32-Bits host addressing.</li> <li>Supports 3D / 2D graphic</li> <li>Supports up to 2 double-sided DIMM (4 device rows)</li> <li>PCI Rev. 2.2, 3.3V (5V Tolerant), 33 MHz interface compliant and PCI to System Memory Data Streaming up to 132 MB/sec</li> <li>Upstream Hub Interface for access to the Intel GMCH.</li> <li>2 Channel Ultra ATA/100 Bus Master IDE Controllers</li> <li>Supports six USB 2.0 ports for serial transfers at 480Mbits/sec</li> </ul> <p>Additional key features include support for an AC'97 link for audio and modem, hardware monitoring, and ACPI/OnNow power management.</p> |  |    |     |       |             |  |       |             |  |
| <b>Memory</b>             | <p>The motherboard accommodates two unbuffered 2.5V 184 pin slots with a total maximum capacity of 2 GB.</p>  |  |    |     |       |             |  |       |             |  |
| <b>AC' 97 Audio Codec</b> | <p>The AC' 97 Audio CODEC is compliant with the AC'97 2.2 specification that meets the PC2001 requirements and supports S/PDIF Out. It also has a built-in buffer and internal PLL. Features include support for analog switch for rear-out (share), the line-in jack (share), center/bass (share), and MIC jack to output 6 channels audio.</p>  |  |    |     |       |             |  |       |             |  |
| <b>Expansion Options</b>  | <p>The motherboard comes with the following expansion options:</p> <ul style="list-style-type: none"> <li>One ADD slot</li> <li>Three 32-bit PCI slots</li> <li>A Communications Network Riser (CNR) slot (AC'97 interface only)</li> <li>Two IDE connectors which support four IDE channels</li> <li>One floppy disk drive interface</li> <li>One Onboard LAN (optional) chip and LAN port on top of the USB port</li> </ul>   |  |    |     |       |             |  |       |             |  |

|                               |  |
|-------------------------------|--|
|                               | The motherboard supports Ultra DMA bus mastering with transfer rates of 100/66/33 MB/sec.  |
| <b>Integrated I/O</b>         | The motherboard has a full set of I/O ports and connectors: <ul style="list-style-type: none"> <li>• Two PS/2 ports for mouse and keyboard</li> <li>• One serial port</li> <li>• One VGA port</li> <li>• One parallel port</li> <li>• Four USB ports</li> <li>• One LAN port</li> </ul> Audio jacks for microphone, line-in and line-out   |
| <b>Onboard LAN (optional)</b> | The onboard LAN chipset is incorporated in the chipset providing the motherboard with integrated Fast Ethernet controller capabilities and 10/100 mega bit per second (Mbps) Physical Layer Transceivers for the PCI local bus.  |
| <b>BIOS Firmware</b>          | This motherboard uses Award BIOS that enables users to configure many system features including the following: <ul style="list-style-type: none"> <li>• Power management</li> <li>• Wake-up alarms</li> <li>• CPU parameters and memory timing</li> <li>• CPU and memory timing</li> </ul> The firmware can also be used to set parameters for different processor clock speeds. |



Some hardware specifications and software items are subject to change without prior notice.

## Choosing a Computer Case

There are many types of computer cases on the market. The motherboard complies with the specifications for the Micro-ATX system case. Some features on the motherboard are implemented by cabling connectors on the motherboard to indicators and switches on the system case. Ensure that your case supports all the features required. The motherboard can support one or two floppy diskette drives and four enhanced IDE drives. Ensure that your case has sufficient power and space for all the drives that you intend to install.

Most cases have a choice of I/O templates in the rear panel. Make sure that the I/O template in the case matches the I/O ports installed on the rear edge of the motherboard.

This motherboard has a Micro-ATX form factor of 244 mm x 200 mm. Choose a case that accommodates this form factor.

## Motherboard Components

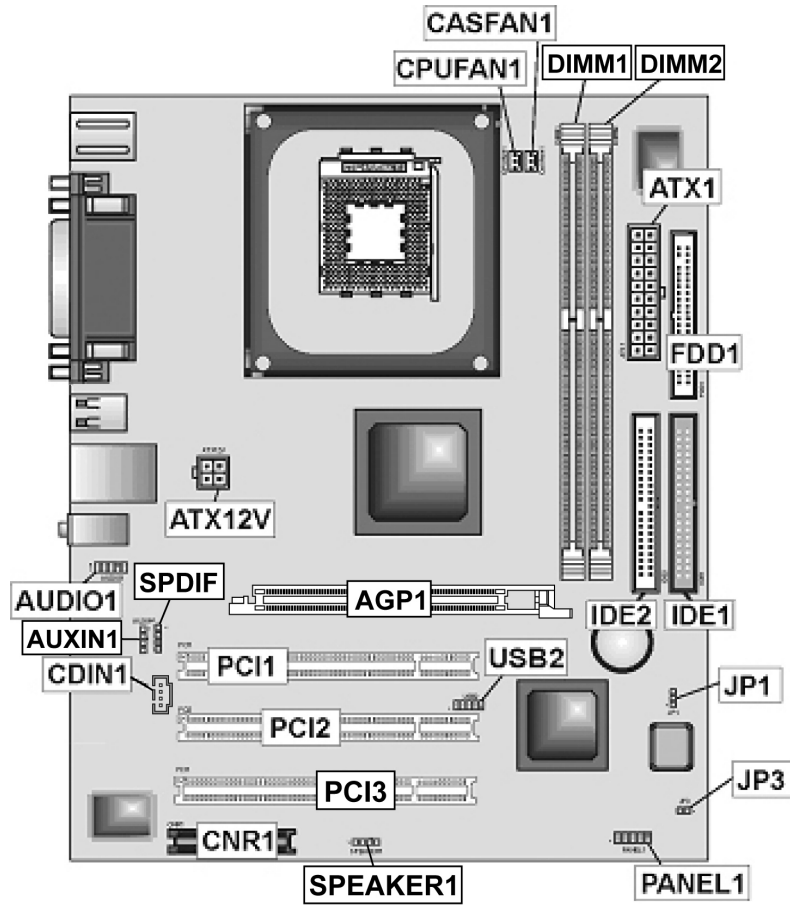



## Table of Motherboard Components

| Label         | Component                                  |
|---------------|--|
| AGP1          | ADD slot                                   |
| ATX1          | Standard 20-pin ATX power connector        |
| ATX12V        | Power connector                            |
| AUDIO1        | Front panel MIC/Speaker Out header         |
| AUXIN1        | Auxilliary In header                       |
| CDIN1         | Primary CD-in connector                    |
| CNR1          | Communications and Networking Riser slot   |
| CASFAN1       | Case fan connector                         |
| CPUFAN1       | Cooling fan for CPU                        |
| CPU Socket    | CPU socket (mPGA478)                       |
| DIMM1 ~ DIMM2 | Two 184-pin DDR sockets                    |
| FDD1          | Floppy disk drive connector                |
| IDE1          | Primary IDE channel                        |
| IDE2          | Secondary IDE channel                      |
| JP1           | Clear CMOS jumper                          |
| JP3           | BIOS flash protect jumper                  |
| PANEL1        | Panel connector for case switches and LEDs |
| PCI1 ~ PCI3   | Three 32-bit add-on card slots             |
| SPDIF         | SPDIF out header                           |
| SPEAKER1      | Speaker header                             |
| USB2          | Connector for front panel USB ports        |

This concludes Chapter 1. The next chapter explains how to install the motherboard.

---

---

## *Chapter 2*

# Installing the Motherboard

---

### **Safety Precautions**

Follow these safety precautions when installing the motherboard:

- Wear a grounding strap attached to a grounded device to avoid damage from static electricity.
- Discharge static electricity by touching the metal case of a safely grounded object before working on the motherboard.
- Leave components in the static-proof bags they came in.
- Hold all circuit boards by the edges. Do not bend circuit boards.

---

### **Quick Guide**

This Quick Guide suggests the steps you can take to assemble your system with the motherboards.

The following table provides a reference for installing specific components:

|   |               |
|---|---------------|
| <b>Locating Motherboard Components</b>      | Go to page 4  |
| <b>Installing the Motherboard in a Case</b> | Go to page 7  |
| <b>Setting Jumpers</b>                      | Go to page 7  |
| <b>Installing Case Components</b>           | Go to page 9  |
| <b>Installing the Processor</b>             | Go to page 12 |
| <b>Installing Memory</b>                    | Go to page 15 |
| <b>Installing an HDD and CD-ROM Drive</b>   | Go to page 16 |
| <b>Installing an FDD</b>                    | Go to page 17 |
| <b>Installing Add-on Cards</b>              | Go to page 18 |
| <b>Connecting Options</b>                   | Go to page 20 |
| <b>Connecting Peripheral (I/O) Devices</b>  | Go to page 22 |

---

## Installing the Motherboard in a Case

Refer to the following illustration and instructions for installing the motherboard in a case:

This illustration shows an example of a motherboard being installed in a tower-type case:

**Note:** Do not overtighten the screws as this can stress the motherboard.

Most system cases have mounting brackets installed in the case, which correspond to the holes in the motherboard. Place the motherboard over the mounting brackets and secure the motherboard onto the mounting brackets with screws.

2. Secure the mainboard with screws where appropriate.

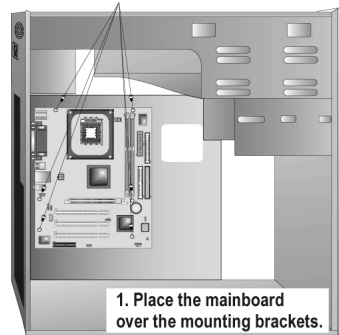

Ensure that your case has an I/O template that supports the I/O ports and expansion slots on your motherboard.

---

## Checking Jumper Settings

This section explains how to set jumpers for correct configuration of the motherboard.

### Setting Jumpers

Use the motherboard jumpers to set system configuration options. Jumpers with more than one pin are numbered. When setting the jumpers, ensure that the jumper caps are placed on the correct pins.

The illustrations below show a 2-pin jumper. When the jumper cap is placed on both pins, the jumper is SHORT. If you remove the jumper cap, or place the jumper cap on just one pin, the jumper is OPEN.

This illustration shows a 3-pin jumper. Pins 1 and 2 are SHORT.

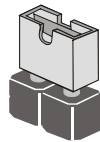

Short

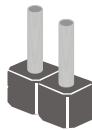

Open

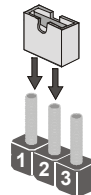

## Checking Jumper Settings

The following illustration shows the location of the motherboard jumpers. Pin 1 is labeled.

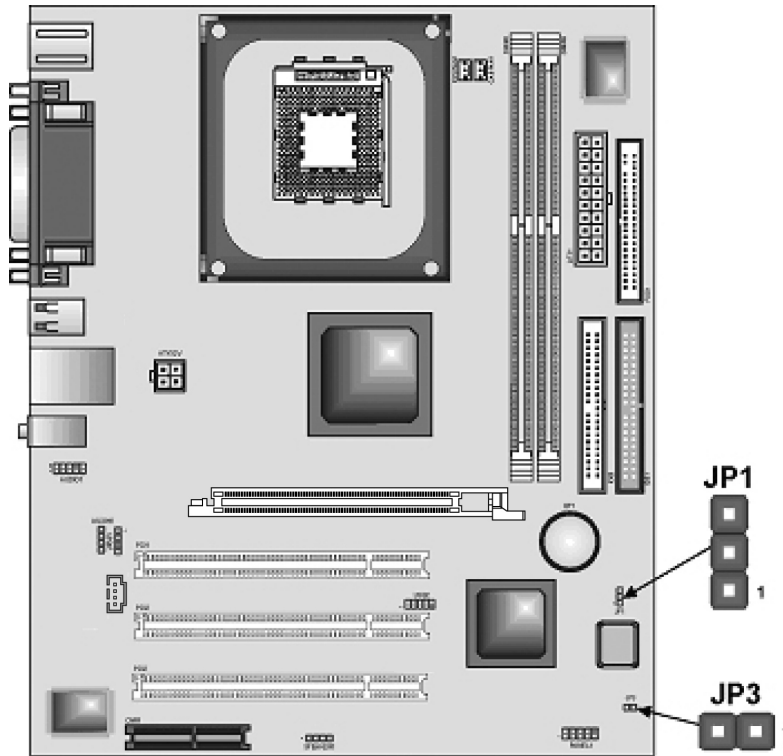

## Jumper Settings

| Jumper | Type  | Description        | Setting  |
|--------|-------|--------------------|--|
| JP1    | 3-pin | Clear CMOS         | 1-2: Normal<br>2-3: Clear CMOS<br>Before clearing the CMOS, make sure to turn off the system |
| JP3    | 2-pin | BIOS Write Protect | Open: Write Enable<br>Short: Write Disable   |

## Connecting Case Components

After you have installed the motherboard into a case, you can begin connecting the motherboard components. Refer to the following:

1. Connect the CPU cooling fan cable to **CPUFAN1**.
2. Connect the case cooling fan connector to **CASFAN1**.
3. Connect the case speaker cable to **SPEAKER1**.
4. Connect the case switches and indicator to **PANEL1**.
5. Connect the standard power supply connector to **ATX1**<sup>1</sup>.
6. Connect the Pentium 4 processor auxiliary case power supply connector to **ATX12V**<sup>1</sup>.

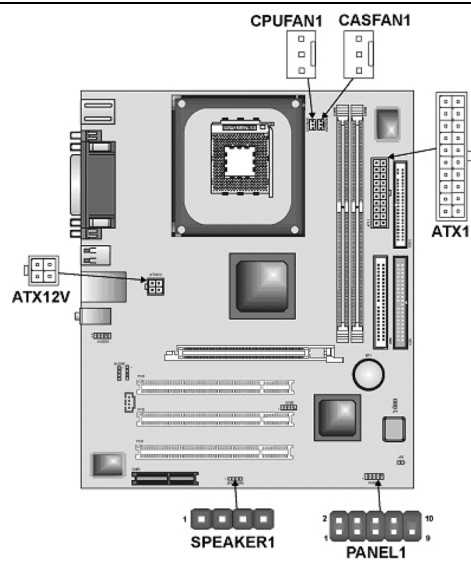

**Note:** When the system is heavily loaded, you should install, at a minimum, an ATX12V power supply with a 300W capacity.

### CPUFAN1/CASFAN1: FAN Power Connectors

| Pin | Signal Name | Function      |
|-----|-------------|---------------|
| 1   | GND         | System Ground |
| 2   | +12V        | Power +12V    |
| 3   | Sense       | Sensor        |

<sup>1</sup> You can either use the 5V or 12V ATX power; the mainboard can work properly on both power supplies.

**SPEAKER1: Internal speaker**

| Pin | Signal Name |
|-----|-------------|
| 1   | Signal      |
| 2   | Buzzer      |
| 3   | NC          |
| 4   | VCC         |

**ATX1: ATX 20-pin Power Connector**

| Pin | Signal Name | Pin | Signal Name |
|-----|-------------|-----|-------------|
| 1   | +3.3V       | 11  | +3.3V       |
| 2   | +3.3V       | 12  | -12V        |
| 3   | Ground      | 13  | Ground      |
| 4   | +5V         | 14  | PS ON#      |
| 5   | Ground      | 15  | Ground      |
| 6   | +5V         | 16  | Ground      |
| 7   | Ground      | 17  | Ground      |
| 8   | PWRGD       | 18  | -5V         |
| 9   | +5VSB       | 19  | +5V         |
| 10  | +12V        | 20  | +5V         |

**ATX12: ATX 12V Power Connector**

| Pin | Signal Name |
|-----|-------------|
| 1   | Ground      |
| 2   | Ground      |
| 3   | +12V        |
| 4   | +12V        |

## Front Panel Connector

The front panel connector (PANEL1) provides a standard set of switch and LED connectors commonly found on ATX or micro-ATX cases. Refer to the table below for information:

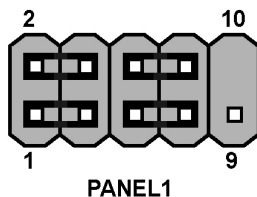

| Pin | Function                        | Pin | Function                                 |
|-----|---------------------------------|-----|--|
| 1   | Hard disk LED (positive)        | 2   | MSG LED [dual color or single color (+)] |
| 3   | Hard disk active LED (negative) | 4   | MSG LED [dual color or single color (-)] |
| 5   | Reset Switch                    | 6   | Power Switch                             |
| 7   | Reset Switch                    | 8   | Power Switch                             |
| 9   | Reserved                        | 10  | No pin                                   |

### **Hard Drive Activity LED**

Connecting pins 1 and 3 to a front panel mounted LED provides visual indication that data is being read from or written to the hard drive. For the LED to function properly, an IDE drive should be connected to the onboard IDE interface. The LED will also show activity for devices connected to the SCSI (hard drive activity LED) connector.

### **Power / Sleep / Message Waiting LED**

Connecting pins 2 and 4 to a single- or dual-color, front panel mounted LED provides power on/off, sleep, and message waiting indication.

### **Reset Switch**

Supporting the reset function requires connecting pins 5 and 7 to a momentary-contact switch that is normally open. When the switch is closed, the board resets and runs POST.

### **Power Switch**

Supporting the power on/off function requires connecting pins 6 and 8 to a momentary-contact switch that is normally open. The switch should maintain contact for at least 50 ms to signal the power supply to switch on or off. The time requirement is due to internal debounce circuitry. After receiving a power on/off signal, at least two seconds elapses before the power supply recognizes another on/off signal.

---

## Installing Hardware

### Installing the Processor

**Caution:** When installing a CPU heatsink and cooling fan make sure that you **DO NOT** scratch the motherboard or any of the surface-mount resistors with the clip of the cooling fan. If the clip of the cooling fan scrapes across the motherboard, you may cause serious damage to the motherboard or its components.

On most motherboards, there are small surface-mount resistors near the processor socket, which may be damaged if the cooling fan is carelessly installed.

Avoid using cooling fans with sharp edges on the fan casing and the clips. Also, install the cooling fan in a well-lit work area so that you can clearly see the motherboard and processor socket.

### Before installing the Processor

This motherboard automatically determines the CPU clock frequency and system bus frequency for the processor. You may be able to change these settings by making changes to jumpers on the motherboard, or changing the settings in the system Setup Utility. We strongly recommend that you do not overclock processors or other components to run faster than their rated speed.

**Warning:** Overclocking components can adversely affect the reliability of the system and introduce errors into your system. Overclocking can permanently damage the motherboard by generating excess heat in components that are run beyond the rated limits.

This motherboard has an mPGA478 socket. When choosing a processor, consider the performance requirements of the system. Performance is based on the processor design, the clock speed and system bus frequency of the processor, and the quantity of internal cache memory and external cache memory.



## CPU Installation Procedure

The following illustration shows CPU installation components:

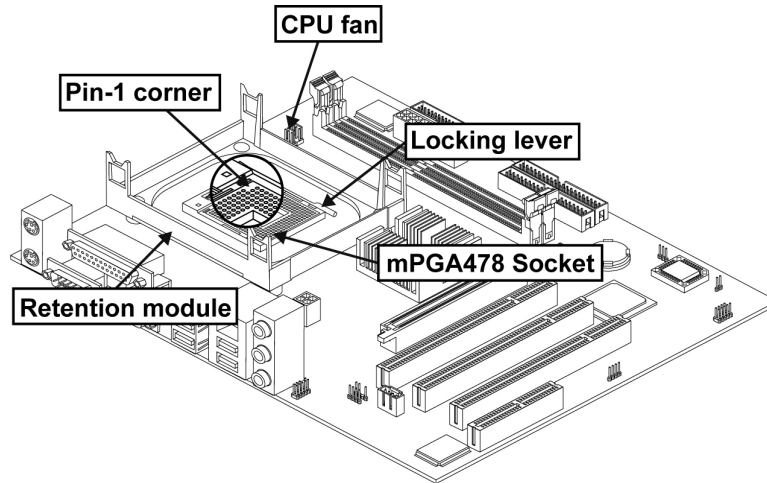

---

**Note:** The pin-1 corner is marked with an arrow ▼

---

Follow these instructions to install the Retention Module and CPU:

1. Install your CPU. Pull up the lever away from the socket and lift up to 90-degree angle.

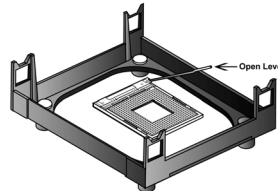

2. Locate the CPU cut edge (the corner with the pinhole noticeably missing). Align and insert the CPU correctly.

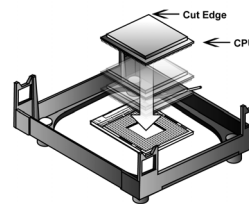

3. Press the lever down.

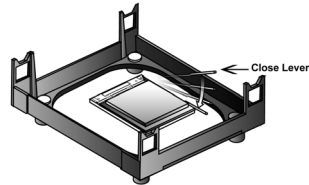

4. Apply thermal grease on top of the CPU.

5. Put the CPU Fan down on the retention module and snap the four retention legs of the cooling fan into place.

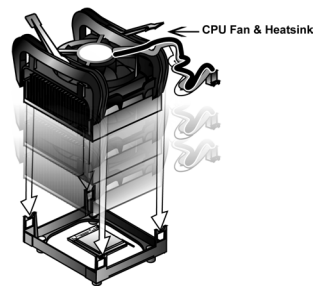

6. Flip the levers over to lock the heat sink in place.

7. Connect the CPU Cooling Fan power cable to the CPUFAN1 connector. This completes the installation.

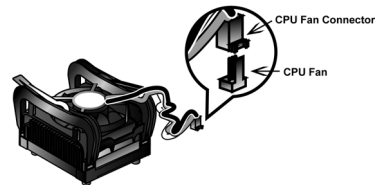

**Notes:** To achieve better airflow rates and heat dissipation, we suggest that you use a high quality fan with 4800 rpm at least. CPU fan and heatsink installation procedures may vary with the type of CPU fan/heatsink supplied. The form and size of fan/heatsink may also vary.

## Installing Memory Modules

This motherboard accommodates two 184-pin 2.5V unbuffered Double Data Rate (DDR) SDRAM memory modules. The memory chips must be standard or registered SDRAM (Synchronous Dynamic Random Access Memory).

When you installed DDR333 memory modules, the memory bus can run up to 166 MHz. If you have DDR266, this can operate over a 133 MHz. For DDR200, it can only run up to 100 MHz.

You must install at least one module in any of the two slots. Each module can be installed with 32 MB to 1 GB of memory; total memory capacity is 2 GB.



Do not remove any memory module from its antistatic packaging until you are ready to install it on the motherboard. Handle the modules only by their edges. Do not touch the components or metal parts. Always wear a grounding strap when you handle the modules.

## Installation Procedure

Refer to the following to install the memory modules.

1. This motherboard supports unbuffered DDR SDRAM only. Do not attempt to insert any other type of DDR SDRAM into the slots.



2. Push the latches on each side of the DIMM slot down.

3. Align the memory module with the slot. The DIMM slots are keyed with notches and the DIMMs are keyed with cutouts so that they can only be installed correctly.

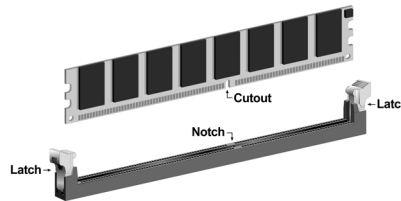

4. Check that the cutouts on the DIMM module edge connector match the notches in the DIMM slot.

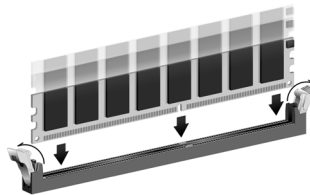

5. Install the DIMM module into the slot and press it firmly down until it seats correctly. The slot latches are levered upwards and latch on to the edges of the DIMM.

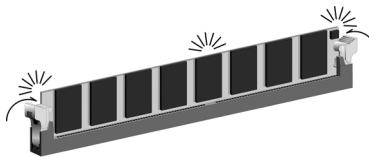

6. Install any remaining DIMM modules.

## Installing a Hard Disk Drive/CD-ROM

This section describes how to install IDE devices such as a hard disk drive and a CD-ROM drive.

Your motherboard has a primary and secondary IDE channel interface (IDE1 and IDE2). An IDE ribbon cable supporting two IDE devices is bundled with the motherboard.

If you want to install more than two IDE devices, get a second IDE cable and you can add two more devices to the secondary IDE channel.

 You must orient the cable connector so that the pin 1 (color) edge of the cable corresponds to the pin 1 of the I/O port connector.

### IDE1: Primary IDE Connector

The first hard drive should always be connected to IDE1.

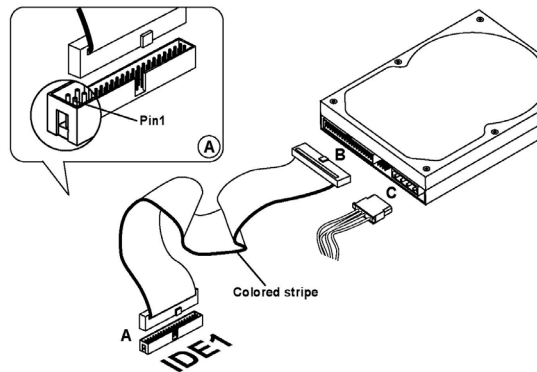

### IDE2: Secondary IDE

The second drive on this controller must be set to slave mode. The configuration is the same as IDE1.

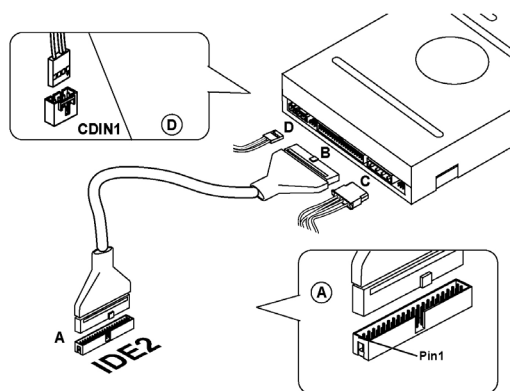

IDE devices have jumpers or switches that are used to set the IDE device as MASTER or SLAVE. Refer to the IDE device user's manual. When installing two IDE devices on one cable, ensure that one device is set to MASTER and the other device is set to SLAVE. The documentation of your IDE device explains how to do this.

## About UltraDMA

This motherboard supports UltraDMA 100/66/33. UDMA is a technology that accelerates the performance of devices in the IDE channel. To maximize performance, install IDE devices that support UDMA and use 80-pin IDE cables that support UDMA 100/66/33.

## Installing a Floppy Diskette Drive

The motherboard has a floppy diskette drive (FDD) interface and ships with a diskette drive ribbon cable that supports one or two floppy diskette drives. You can install a 5.25-inch drive and a 3.5-inch drive with various capacities. The floppy diskette drive cable has one type of connector for a 5.25-inch drive and another type of connector for a 3.5-inch drive.



You must orient the cable connector so that the pin 1 (color) edge of the cable corresponds to the pin 1 of the I/O port connector.

### FDD1: Floppy Disk Connector

This connector supports the provided floppy drive ribbon cable. After connecting the single end to the onboard floppy connector, connect the remaining plugs on the other end to the floppy drives correspondingly.

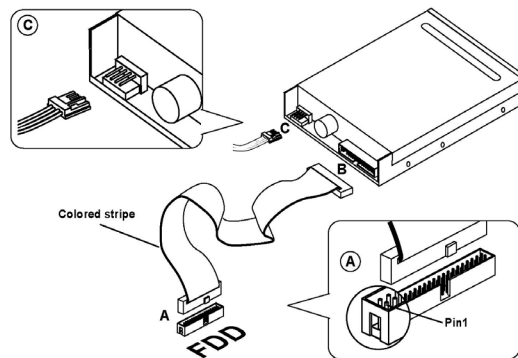

## Installing Add-on Cards

The slots in this motherboard are designed to hold expansion cards and connect them to the system bus. Expansion slots are a means of adding or enhancing the motherboard's features and capabilities. With these efficient facilities, you can increase the motherboard's capabilities by adding hardware which performs tasks that are not part of the basic system.

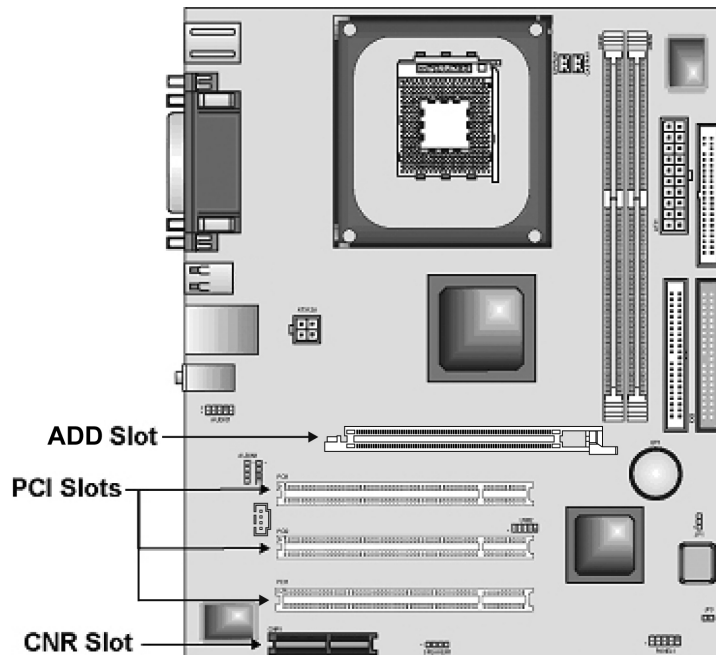

- ADD Slot (AGP1)** This slot support Intel ADD (AGP Digital Display) Card which allows configuration for TV-out, LDVS and TMDS output.
- PCI Slots** PCI slots are used to install expansion cards that have the 32-bit PCI interface.
- CNR Slot** This slot is used to insert CNR cards with Modem and Audio functionality.

---

**Note:** Before installing an add-on card, check the documentation for the card carefully. If the card is not Plug and Play, you may have to manually configure the card before installation.

---

Follow these instructions to install an add-on card:

1. Remove a blanking plate from the system case corresponding to the slot you are going to use.

2. Install the edge connector of the add-on card into the expansion slot. Ensure that the edge connector is correctly seated in the slot.

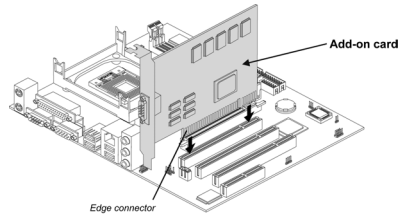

3. Secure the metal bracket of the card to the system case with a screw.

**Note:** For some add-on cards, for example graphics adapters and network adapters, you have to install drivers and software before you can begin using the add-on card.

## Connecting Optional Devices

Refer to the following for information on connecting the motherboard's optional devices:

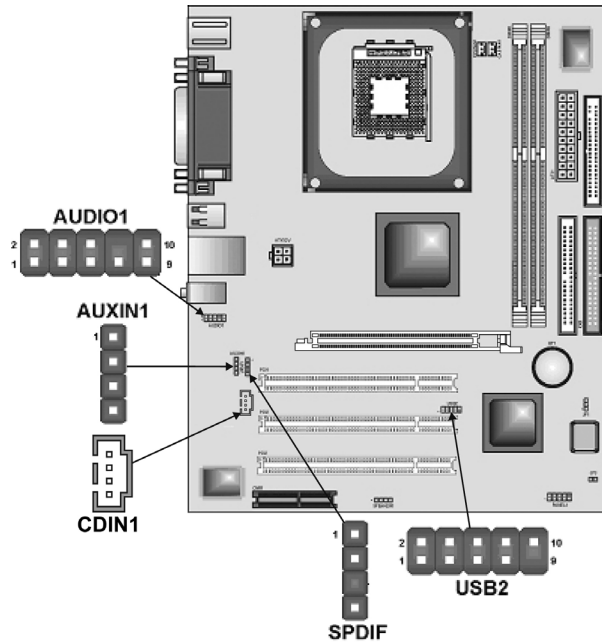

### AUDIO1: Front Panel Audio header

This header allows the user to install auxiliary front-oriented microphone and line-out ports for easier access.

| Pin | Signal Name  | Function  |
|-----|--------------|---|
| 1   | AUD_MIC      | Front Panel Microphone input signal                     |
| 2   | AUD_GND      | Ground used by Analog Audio Circuits                    |
| 3   | AUD_MIC_BIAS | Microphone Power  |
| 4   | AUD_VCC      | Filtered +5 V used by Analog Audio Circuits             |
| 5   | AUD_FPOUT_R  | Right Channel Audio signal to Front Panel               |
| 6   | AUD_RET_R    | Right Channel Audio signal to Return from Front Panel   |
| 7   | HP_ON        | Reserved for future use to control Head-phone Amplifier |
| 8   | KEY          | No Pin  |
| 9   | AUD_FPOUT_L  | Left Channel Audio signal to Front Panel                |
| 10  | AUD_RET_L    | Left Channel Audio signal Return from Front Panel       |



## USB2: Front panel USB ports

The motherboard has two USB ports installed on the rear edge I/O port array. Additionally, some computer cases have USB ports at the front of the case. If you have this kind of case, use auxiliary USB connector USB2 to connect the front-mounted ports to the motherboard.

| Pin | Signal Name     | Function                   |
|-----|-----------------|----------------------------|
| 1   | VREG_FP_USBPWR0 | Front Panel USB Power      |
| 2   | VREG_FP_USBPWR0 | Front Panel USB Power      |
| 3   | USB_FP_P0-      | USB Port 0 Negative Signal |
| 4   | USB_FP_P1-      | USB Port 1 Negative Signal |
| 5   | USB_FP_P0+      | USB Port 0 Positive Signal |
| 6   | USB_FP_P1+      | USB Port 1 Positive Signal |
| 7   | GND             | Ground                     |
| 8   | GND             | Ground                     |
| 9   | KEY             | No pin                     |
| 10  | USB_FP_OC0      | Overcurrent signal         |

**Note:** Please make sure that the USB cable has the same pin assignment as indicated above. A different pin assignment may cause damage or system hang-up.

## AUXIN1: Auxilliary In header

This connector is an additional line-in audio connector. It allows you to attach a line-in cable when your rear line-in jack is set as line out port for 4-channel function.

| Pin | Signal Name | Function             |
|-----|-------------|----------------------|
| 1   | AUX_L       | AUX In left channel  |
| 2   | GND         | Ground               |
| 3   | GND         | Ground               |
| 4   | AUX_R       | AUX In right channel |

## CD-in: CD Audio Input header

| Pin | Signal Name | Function            |
|-----|-------------|---------------------|
| 1   | CD in_L     | CD In left channel  |
| 2   | GND         | Ground              |
| 3   | GND         | Ground              |
| 4   | CD in_R     | CD In right channel |

## SPDIF1: SPDIF out header

This is an optional header that provides an S/PDIF (Sony/Philips Digital Interface) output to digital multimedia device through optical fiber or coaxial connector.

| Pin | Signal Name |
|-----|-------------|
| 1   | SPDIF Out   |
| 2   | VCC         |
| 3   | KEY         |
| 4   | GND         |

---

## Connecting I/O Devices

The backplane of the motherboard has the following I/O ports:

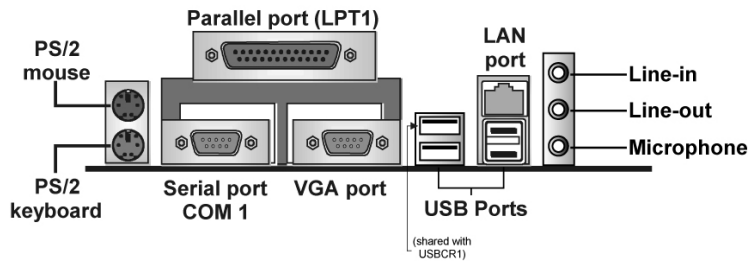

- PS/2 Mouse** Use the upper PS/2 port to connect a PS/2 pointing device.
- PS/2 Keyboard** Use the lower PS/2 port to connect a PS/2 keyboard.
- LPT1** Use LPT1 to connect printers or other parallel communications devices.
- COM1** Use the COM ports to connect serial devices such as mice or fax/modems. COM1 is identified by the system as COM1/3.
- VGA Port** Connect your monitor to the VGA port.
- Audio Ports** Use the three audio ports to connect audio devices. The first jack is for stereo line-in signal. The second jack is for stereo line-out signal. The third jack is for microphone.
- LAN Port** Connect an RJ-45 jack to the LAN port to connect your computer to the Network.
- USB Ports** Use the USB ports to connect USB devices.

This concludes Chapter 2. The next chapter covers the BIOS.

## *Chapter 3*

# Using BIOS

---

### **About the Setup Utility**

The computer uses the latest Award BIOS with support for Windows Plug and Play. The CMOS chip on the motherboard contains the ROM setup instructions for configuring the motherboard BIOS.

The BIOS (Basic Input and Output System) Setup Utility displays the system's configuration status and provides you with options to set system parameters. The parameters are stored in battery-backed-up CMOS RAM that saves this information when the power is turned off. When the system is turned back on, the system is configured with the values you stored in CMOS.

The BIOS Setup Utility enables you to configure:

- Hard drives, diskette drives, and peripherals
- Video display type and display options
- Password protection from unauthorized use
- Power management features

The settings made in the Setup Utility affect how the computer performs. Before using the Setup Utility, ensure that you understand the Setup Utility options.

This chapter provides explanations for Setup Utility options.

### **The Standard Configuration**

A standard configuration has already been set in the Setup Utility. However, we recommend that you read this chapter in case you need to make any changes in the future.

This Setup Utility should be used:

- when changing the system configuration
- when a configuration error is detected and you are prompted to make changes to the Setup Utility
- when trying to resolve IRQ conflicts
- when making changes to the Power Management configuration
- when changing the password or making other changes to the Security Setup



2. If your motherboard has an item called Firmware Write Protect in Advanced BIOS features, disable it. (Firmware Write Protect prevents BIOS from being overwritten.)
3. Create a bootable system disk. (Refer to Windows online help for information on creating a bootable system disk.)
4. Download the Flash Utility and new BIOS file from the manufacturer's Web site. Copy these files to the system diskette you created in Step 3.
5. Turn off your computer and insert the system diskette in your computer's diskette drive. (You might need to run the Setup Utility and change the boot priority items on the Advanced BIOS Features Setup page, to force your computer to boot from the floppy diskette drive first.)
6. At the A:\ prompt, type the Flash Utility program name and press <Enter>.
7. Type the filename of the new BIOS in the "File Name to Program" text box. Follow the onscreen directions to update the motherboard BIOS.
8. When the installation is complete, remove the floppy diskette from the diskette drive and restart your computer. If your motherboard has a Flash BIOS jumper, reset the jumper to protect the newly installed BIOS from being overwritten.

---

## Using BIOS

When you start the Setup Utility, the main menu appears. The main menu of the Setup Utility displays a list of the options that are available. A highlight indicates which option is currently selected. Use the cursor arrow keys to move the highlight to other options. When an option is highlighted, execute the option by pressing <Enter>.

Some options lead to pop-up dialog boxes that prompt you to verify that you wish to execute that option. Other options lead to dialog boxes that prompt you for information.

Some options (marked with a triangle ►) lead to submenus that enable you to change the values for the option. Use the cursor arrow keys to scroll through the items in the submenu.

In this manual, default values are enclosed in parenthesis. Submenu items are denoted by a triangle ►.

## Standard CMOS Features

This option displays basic information about your system.

CMOS Setup Utility – Copyright (C) 1984 – 2001 Award Software  
Standard CMOS Features

|                        |                   |  |
|------------------------|-------------------|--|
| Date (mm:dd:yy)        | Tue, July 11 2001 | Item Help  |
| Time (hh:mm:ss)        | 12 : 8 : 59       |  |
| ▶ IDE Primary Master   |                   | Menu Level ▶<br>Change the day, month, year and century. |
| ▶ IDE Primary Slave    |                   |  |
| ▶ IDE Secondary Master |                   |  |
| ▶ IDE Secondary Slave  |                   |  |
| Drive A                | [1.44M, 3.5 in.]  |  |
| Drive B                | [None]            |  |
| Floppy 3 Mode Support  | [Disabled]        |  |
| Video                  | [EGA/VGA]         |  |
| Halt On                | [All Errors]      |  |
| Base Memory            | 640K              |  |
| Extended Memory        | 31744K            |  |
| Total Memory           | 32768K            |  |

↑↓→←: Move    Enter : Select    +/-/PU/PD:Value:    F10: Save    ESC: Exit    F1:General Help  
F5:Previous Values    F6:Fail-Safe Defaults    F7:Optimized Defaults

### Date and Time

The Date and Time items show the current date and time on the computer. If you are running a Windows OS, these items are automatically updated whenever you make changes to the Windows Date and Time Properties utility.

### ▶ IDE Devices (None)

Your computer has two IDE channels (Primary and Secondary) and each channel can be installed with one or two devices (Master and Slave). Use these items to configure each device on the IDE channel.

Press <Enter> to display the IDE submenu:

CMOS Setup Utility – Copyright © 1984 – 2001 Award Software  
IDE Primary Master

|                                |               |  |
|--------------------------------|---------------|--|
| IDE HDD Auto-Detection         | [Press Enter] | Item Help  |
| IDE Primary Master Access Mode | [Auto]        |  |
| Capacity                       | 0 MB          | Menu Level ▶▶<br>To auto-detect the HDD's size, head . . . on this channel |
| Cylinder                       | 0             |  |
| Head                           | 0             |  |
| Precomp                        | 0             |  |
| Landing Zone                   | 0             |  |
| Sector                         | 0             |  |

↑↓→←: Move    Enter : Select    +/-/PU/PD:Value:    F10: Save    ESC: Exit    F1:General Help  
F5:Previous Values    F6:Fail-Safe Defaults    F7:Optimized Defaults

### **IDE HDD Auto-Detection**

Press <Enter> while this item is highlighted to prompt the Setup Utility to automatically detect and configure an IDE device on the IDE channel.

---

**Note:** If you are setting up a new hard disk drive that supports LBA mode, more than one line will appear in the parameter box. Choose the line that lists LBA for an LBA drive.

---

### **IDE Primary/Secondary Master/Slave (Auto)**

Leave this item at Auto to enable the system to automatically detect and configure IDE devices on the channel. If it fails to find a device, change the value to Manual and then manually configure the drive by entering the characteristics of the drive in the items described below.

Refer to your drive's documentation or look on the drive casing if you need to obtain this information. If no device is installed, change the value to None.

---

**Note:** Before attempting to configure a hard disk drive, ensure that you have the configuration information supplied by the manufacturer of your hard drive. Incorrect settings can result in your system not recognizing the installed hard disk.

---

### **Access Mode**

This item defines ways that can be used to access IDE hard disks such as LBA (Large Block Addressing). Leave this value at Auto and the system will automatically decide the fastest way to access the hard disk drive.

Press <Esc> to return to the Standard CMOS Features page.

### **Drive A/Drive B (1.44M, 3.5 in./None)**

These items define the characteristics of any diskette drive attached to the system. You can connect one or two diskette drives.

### **Floppy 3 Mode Support (Disabled)**

Floppy 3 mode refers to a 3.5-inch diskette with a capacity of 1.2 MB. Floppy 3 mode is sometimes used in Japan.

### **Video (EGA/VGA)**

This item defines the video mode of the system. This motherboard has a built-in VGA graphics system; you must leave this item at the default value.

### **Halt On (All Errors)**

This item defines the operation of the system POST (Power On Self Test) routine. You can use this item to select which types of errors in the POST are sufficient to halt the system.

### **Base Memory, Extended Memory, and Total Memory**

These items are automatically detected by the system at start up time. These are display-only fields. You cannot make changes to these fields.

## Advanced BIOS Setup Option

This option defines advanced information about your system.

### Phoenix – AwardBIOS CMOS Setup Utility Advanced BIOS Setup

|                              |               |   |   |
|------------------------------|---------------|---|---|
| ▶ CPU Feature                | [Press Enter] |  | Item Help   |
| CPU L1 & L2 Cache            | [Enabled]     |   | Menu Level ▶  |
| CPU Hyper-Threading          | [Enabled]     |   | Allows you to choose the VIRUS warning feature for IDE Hard Disk boot sector protection. If this function is enabled and someone attempts to write data into this area, BIOS will show a warning message on screen and alarm beep |
| Quick Power On Self Test     | [Enabled]     |   |   |
| First Boot Device            | [Floppy]      |   |   |
| Second Boot Device           | [HDD-0]       |   |   |
| Third Boot Device            | [CDROM]       |   |   |
| Boot Other Device            | [Enabled]     |   |   |
| Swap Floppy Drive            | [Disabled]    |   |   |
| Boot Up Floppy Seek          | [Disabled]    |   |   |
| Boot Up NumLock Status       | [On]          |   |   |
| Gate A20 Option              | [Fast]        |   |   |
| ATA 66/100 Cable MSG         | [Enabled]     |   |   |
| Typematic Rate Setting       | [Disabled]    |   |   |
| x Typematic Rate (Chars/Sec) | 6             |   |   |
| x Typematic Delay (Msec)     | 250           |   |   |
| Security Option              | [Setup]       |   |   |
| APIC Mode                    | [Enabled]     |   |   |
| OS Select For DRAM > 64MB    | [Non-OS2]     |   |   |
| HDD S.M.A.R.T Capability     | [Disabled]    |   |   |

↑↓→←: Move    Enter: Select    +/-/PU/PD: Value    F10: Save    ESC: Exit    F1: General Help  
 F5: Previous Values    F6: Fail-Safe Defaults    F7: Optimized Defaults

### ▶ CPU Feature (Press Enter)

Scroll to this item and press <Enter> to view the following screen, and the following items are only available when the motherboard supports Prescott CPU:

### Phoenix – AwardBIOS CMOS Setup Utility CPU Feature

|                        |                     |   |   |
|------------------------|---------------------|---|---|
| Delay Prior to Thermal | [16 Min]            |  | Item Help   |
| Thermal Management     | [Thermal Monitor 1] |   | Menu Level ▶▶   |
| Limit CPUID MaxVal     | [Disabled]          |   | Thermal Monitor 1 (On die throttling)<br>Thermal Monitor 2 Ratio & VID transition |
|                        |                     |   |   |

↑↓→←: Move    Enter: Select    +/-/PU/PD: Value    F10: Save    ESC: Exit    F1: General Help  
 F5: Previous Values    F6: Fail-Safe Defaults    F7: Optimized Defaults

### Delay Prior to Thermal (16 Min)

Enables you to set the delay time before the CPU enters auto thermal mode.



### **Thermal Management (Thermal Monitor 1)**

This item sets CPU's thermal control rule to protect CPU from overheat. This feature is only available when CPU supports Thermal Monitor 2.

### **Limit CPUID MaxVal (Disabled)**

This item limits the CUID maximum value. Enable this item to install WinNT. Leave this item at the default value for other OS. Please note that this item is available when supports Prescott CPU.

Press <Esc> to return to the Advanced BIOS Features screen.

### **CPU L1 & L2 Cache (Enabled)**

All processors that can be installed in this motherboard use internal level 1 (L1) and external level 2 (L2) cache memory to improve performance. Leave this item at the default value for better performance.

### **Quick Power On Self Test (Enabled)**

Enable this item to shorten the power on testing (POST) and have your system start up faster. You might like to enable this item after you are confident that your system hardware is operating smoothly.

### **First/Second/Third Boot Device (Floppy/HDD-0/CD-ROM)**

Use these three items to select the priority and order of the devices that your system searches for an operating system at start-up time.

### **Boot Other Device (Enabled)**

When enabled, the system searches all other possible locations for an operating system if it fails to find one in the devices specified under the First, Second, and Third boot devices.

### **Swap Floppy Drive (Disabled)**

If you have two floppy diskette drives in your system, this item allows you to swap the assigned drive letters so that drive A becomes drive B, and drive B becomes drive A.

### **Boot Up Floppy Seek (Disabled)**

If this item is enabled, it checks the size of the floppy disk drives at start-up time. You don't need to enable this item unless you have a legacy diskette drive with 360K capacity.

### **Boot Up NumLock Status (On)**

This item defines if the keyboard Num Lock key is active when your system is started.

### **Gate A20 Option (Fast)**

This item defines how the system handles legacy software that was written for an earlier generation of processors. Leave this item at the default value.

### **ATA 66/100 Cable MSG (Enabled)**

This item enables or disables the display of the ATA 66/100 Cable MSG.

### **Typematic Rate Setting (Disabled)**

If this item is enabled, you can use the following two items to set the typematic rate and the typematic delay settings for your keyboard.

- **Typematic Rate (Chars/Sec):** Use this item to define how many characters per second a held-down key generates.
- **Typematic Delay (Msec):** Use this item to define how many milliseconds must elapse before a held-down key begins generating repeat characters.

**Security Option (Setup)**

If you have installed password protection, this item defines if the password is required at system start up, or if it is only required when a user tries to enter the Setup Utility.

**APIC Mode (Enable)**

This option is use to enabled or disabled APIC (Advanced Programmable Interrupt Controller) functionality. The APIC is an Intel chip that provides symmetric multiprocessing (SMP) for its Pentium systems.

**OS Select For DRAM > 64 MB (Non-OS2)**

This item is only required if you have installed more than 64 MB of memory and you are running the OS/2 operating system. Otherwise, leave this item at the default.

**HDD S.M.A.R.T Capability (Disabled)**

The S.M.A.R.T. (Self-Monitoring, Analysis, and Reporting Technology) system is a diagnostics technology that monitors and predicts device performance. S.M.A.R.T. software resides on both the disk drive and the host computer.

**Report No FDD For WIN 95 (Yes)**

Set this item to the default if you are running a system with no floppy drive and using Windows 95; this ensures compatibility with the Windows 95 logo certification.

**Small Logo (EPA) Show (Disabled)**

Enables or disables the display of the EPA logo during boot.

## Advanced Chipset Features Option

These items define critical timing parameters of the motherboard. You should leave the items on this page at their default values unless you are very familiar with the technical specifications of your system hardware. If you change the values incorrectly, you may introduce fatal errors or recurring instability into your system.

CMOS Setup Utility – Copyright (C) 1984 – 2001 Award Software  
Advanced Chipset Features

|                            |            | Item Help    |
|----------------------------|------------|--------------|
| DRAM Timing Selectable     | [Manual]   |              |
| CAS Latency Time           | [2.5]      |              |
| Active to Precharge Delay  | [7]        | Menu Level ▶ |
| DRAM RAS# to CAS# Delay    | [3]        |              |
| DRAM RAS# Precharge        | [3]        |              |
| Turbo Mode                 | [Disabled] |              |
| Command Pre Clock          | [Auto]     |              |
| Memory Frequency For       | [Auto]     |              |
| System BIOS Cacheable      | [Disabled] |              |
| Video BIOS Cacheable       | [Disabled] |              |
| Delayed Transaction        | [Enabled]  |              |
| AGP Aperture Size (MB)     | [128]      |              |
| ** On-Chip VGA Setting **  |            |              |
| On-chip Frame Buffer Size  | [8M]       |              |
| On-chip Video Windows Size | [128]      |              |

↑ ↓ → ← : Move    Enter : Select    +/-/PU/PD:Value:    F10: Save    ESC: Exit    F1:General Help  
F5:Previous Values    F6:Fail-Safe Defaults    F7:Optimized Defaults

### DRAM Timing Selectable (Manual)

The value in this field depends on performance parameters of the installed memory chips (DRAM). Do not change the value from the factory setting unless you install new memory that has a different performance rating than the original DRAMs.

### CAS Latency Time: (2.5)

When synchronous DRAM is installed, the number of clock cycles of CAS latency depends on the DRAM timing. Do not reset this field from the default value specified by the system designer.

### Active to Precharge Delay (7)

The precharge time is the number of cycles it takes for DRAM to accumulate its charge before refresh.

### DRAM RAS# to CAS# Delay (3)

This field lets you insert a timing delay between the CAS and RAS strobe signals, used when DRAM is written to, read from, or refreshed. Disabled gives faster performance; and Enabled gives more stable performance.

### DRAM RAS# Precharge (3)

Select the number of CPU clocks allocated for the Row Address Strobe (RAS#) signal to accumulate its charge before the DRAM is refreshed. If insufficient time is allowed, refresh may be incomplete and data lost.

**Turbo Mode (Disabled)**

This item allows you to speed up the external clock by approximately 2.5%. This feature is used to verify the design flexibility. It is a very important tool for test units to verify CPU stability. It is not recommended that you use this feature.

**Command Pre Clock (Auto)**

Leave this item at Auto to enhance the system performance.

**Memory Frequency For (Auto)**

This item sets the main memory frequency. When you use an external graphics card, you can adjust this to enable the best performance for your system.

**System BIOS Cacheable (Disabled)**

This item allows the system to be cached in memory for faster execution. Enable this item for better performance.

**Video BIOS Cacheable (Disabled)**

These items allow the video BIOS to be cached in memory for faster execution. Enable the item for better performance.

**Delayed Transaction (Enabled)**

The chipset has an embedded 32-bit posted write buffer to support delayed transaction cycles. Enable this item to support compliance with PCI specification version 2.1.

**AGP Aperture Size (128 MB)**

This item defines the size of the aperture if you use an AGP graphics adapter. The AGP aperture refers to a section of the PCI memory address range used for graphics memory. We recommend that you leave this item at the default value.

**On-chip Frame Buffer Size (8M)**

This allows you to set the VGA frame buffer size.

**On-chip Video Windows Size (128 MB)**

This allows you to set the Graphics Aperture size.

## Integrated Peripherals Option

These options display items that define the operation of peripheral components on the system's input/output ports.

CMOS Setup Utility – Copyright (C) 1984 – 2001 Award Software  
Integrated Peripherals

|                      |         |            |              |
|----------------------|---------|------------|--------------|
| On-Chip Primary      | PCI IDE | [Enabled]  | Item Help    |
| IDE Primary Master   | PIO     | [Auto]     |              |
| IDE Primary Slave    | PIO     | [Auto]     | Menu Level ► |
| IDE Primary Master   | UDMA    | [Auto]     |              |
| IDE Primary Slave    | UDMA    | [Auto]     |              |
| On-Chip Secondary    | PCI IDE | [Enabled]  |              |
| IDE Secondary Master | PIO     | [Auto]     |              |
| IDE Secondary Slave  | PIO     | [Auto]     |              |
| IDE Secondary Master | UDMA    | [Auto]     |              |
| IDE Secondary Slave  | UDMA    | [Auto]     |              |
| USB Controller       |         | [Enabled]  |              |
| USB 2.0 Support      |         | [Enabled]  |              |
| USB Keyboard Support |         | [Disabled] |              |
| USB Mouse Support    |         | [Disabled] |              |
| AC97 Audio           |         | [Auto]     |              |
| AC97 Modem           |         | [Auto]     |              |
| Onboard LAN device   |         | [Enabled]  |              |
| Onboard LAN Boot ROM |         | [Disabled] |              |
| Init Display First   |         | [PCI Slot] |              |
| IDE HDD Block Mode   |         | [Enabled]  |              |

↑ ↓ → ← : Move    Enter : Select    +/-/PU/PD: Value    F10: Save    ESC: Exit    F1: General Help  
F5: Previous Values    F6: Fail-Safe Defaults    F7: Optimized Defaults

### On-Chip Primary/Secondary PCI IDE (Enabled)

Use these items to enable or disable the PCI IDE channels that are integrated on the motherboard.

### IDE Primary/Secondary Master/Slave PIO (Auto)

Each IDE channel supports a master device and a slave device. These four items let you assign which kind of PIO (Programmed Input/Output) is used by IDE devices. Choose Auto to let the system auto detect which PIO mode is best, or select a PIO mode from 0-4.

### IDE Primary/Secondary Master/Slave UDMA (Auto)

Each IDE channel supports a master device and a slave device device. This motherboard supports UltraDMA technology, which provides faster access to IDE devices.

If you install a device that supports UltraDMA, change the appropriate item on this list to Auto. You may have to install the UltraDMA driver supplied with this motherboard in order to use an UltraDMA device.

### USB Controller (Enabled)

Enable this item if you plan to use the Universal Serial Bus ports on this motherboard.

### USB 2.0 Support (Enabled)

Select enabled if your system support the USB 2.0 function.

**USB Keyboard Support (Disabled)**

Enable this item if you plan to use a keyboard connected through the USB port in a legacy operating system (such as DOS) that does not support Plug and Play.

**USB Mouse Support (Disabled)**

Enable this item if you plan to use a USB mouse.

**AC97 Audio (Auto)**

Enables and disables the onboard audio chip. Disable this item if you are going to install a PCI audio add-on card.

**AC97 Modem (Auto)**

Enables and disables the onboard modem. Disable this item if you are going to install an external modem.

**Onboard LAN Device (Enabled)**

Enables and disables the onboard LAN.

**Onboard LAN BOOT ROM (Disabled)**

This item allows you to enable or disable the onboard LAN Boot ROM function.

**Init Display First (PCI Slot)**

Use this item to specify whether your graphics adapter is installed in one of the PCI slots or is integrated on the motherboard.

**IDE HDD Block Mode (Enabled)**

Enable this field if your IDE hard drive supports block mode. Block mode enables BIOS to automatically detect the optimal number of block read and writes per sector that the drive can support and improves the speed of access to IDE devices.

**Onboard FDC Controller (Enabled)**

This option enables the onboard floppy disk drive controller.

**Onboard Serial Port 1 (3F8/IRQ4)**

This option is used to assign the I/O address and interrupt request (IRQ) for the onboard serial port 1 (COM1).

**Onboard Parallel Port (378/IRQ7)**

This option is used to assign the I/O address and interrupt request (IRQ) for the onboard parallel port.

**Parallel Port Mode (ECP)**

Enables you to set the data transfer protocol for your parallel port. There are four options: SPP (Standard Parallel Port), EPP (Enhanced Parallel Port), ECP (Extended Capabilities Port), and ECP+EPP.

SPP allows data output only. Extended Capabilities Port (ECP) and Enhanced Parallel Port (EPP) are bi-directional modes, allowing both data input and output.

ECP and EPP modes are only supported with EPP- and ECP-aware peripherals.

**EPP Mode Select (EPP 1.7)**

The onboard parallel port is EPP spec. compliant, after you choose the onboard parallel port with EPP function. Set the EPP version to 1.7 spec or 1.9 spec.

**ECP Mode Use DMA (3)**

When the onboard parallel port is set to ECP mode, the parallel port can use DMA 3 or DMA 1.

## Power Management Setup Option

This option lets you control system power management. The system has various power-saving modes including powering down the hard disk, turning off the video, suspending to RAM, and software power down that allows the system to be automatically resumed by certain events.

The power-saving modes can be controlled by timeouts. If the system is inactive for a time, the timeouts begin counting. If the inactivity continues so that the timeout period elapses, the system enters a power-saving mode. If any item in the list of Reload Global Timer Events is Enabled, then any activity on that item will reset the timeout counters to zero.

If the system is suspended or has been powered down by software, it can be resumed by a wake up call that is generated by incoming traffic to a modem, a LAN card, a PCI card, or a fixed alarm on the system realtime clock.

CMOS Setup Utility – Copyright (C) 1984 – 2001 Award Software  
Power Management Setup

|                                  |               | Item Help |
|----------------------------------|---------------|-----------|
| ACPI Function                    | [Enabled]     |           |
| Power Management                 | [User Define] |           |
| Video Off Method                 | [DPMS]        |           |
| Video Off In Suspend             | [Yes]         |           |
| Suspend Type                     | [Stop Grant]  |           |
| MODEM Use IRQ                    | [3]           |           |
| Suspend Mode                     | [Disabled]    |           |
| HDD Power Down                   | [Disabled]    |           |
| HDD Off When Suspend             | [Disabled]    |           |
| Soft-Off by PWR-BTTN             | [Instant-Off] |           |
| CPU THRM-Throttling              | [50%]         |           |
| Wake-Up by PCI card              | [Enabled]     |           |
| Resume by Alarm                  | [Disabled]    |           |
| x Date (of Month) Alarm          | 0             |           |
| x Time (hh:mm:ss) Alarm          | 0 0 0         |           |
| ** Reload Global Timer Events ** |               |           |

↑ ↓ → ← : Move    Enter : Select    +/-/PU/PD:Value:    F10: Save    ESC: Exit    F1:General Help  
F5:Previous Values    F6:Fail-Safe Defaults    F7:Optimized Defaults

### ACPI Function (Enabled)

This motherboard supports ACPI (Advanced Configuration and Power management Interface). Use this item to enable or disable the ACPI feature.

**Note:** ACPI is a power management specification that makes hardware status information available to the operating system. ACPI enables a PC to turn its peripherals on and off for improved power management. It also allows the PC to be turned on and off by external devices, so that mouse or keyboard activity wakes up the computer.

### Power Management (User Define)

This item acts like a master switch for the power-saving modes and hard disk timeouts. If this item is set to Max Saving, power-saving modes occur after a



short timeout. If this item is set to Min Saving, power-saving modes occur after a longer timeout. If the item is set to User Define, you can insert your own timeouts for the power-saving modes.

**Video Off Method (DPMS)**

This item defines how the video is powered down to save power. This item is set to DPMS (Display Power Management Software) by default.

**Video Off In Suspend (Yes)**

This option defines if the video is powered down when the system is put into suspend mode.

**Suspend Type (Stop Grant)**

If this item is set to the default Stop Grant, the CPU will go into Idle Mode during power saving mode.

**MODEM Use IRQ (3)**

If you want an incoming call on a modem to automatically resume the system from a power-saving mode, use this item to specify the interrupt request line (IRQ) that is used by the modem. You might have to connect the fax/modem to the motherboard Wake On Modem connector for this feature to work.

**Suspend Mode (Disable)**

The CPU clock will be stopped and the video signal will be suspended if no Power Management events occur for a specified length of time. Full power function will return when a Power Management event is detected. Options are from 1 Min to 1 Hour and Disable.

**HDD Power Down (Disable)**

The IDE hard drive will spin down if it is not accessed within a specified length of time. Options are from 1 Min to 15 Min and Disable.

**HDD Off When Suspend (Disabled)**

This option defines if the hard disk drive is powered down when the system is put into suspend mode.

**Soft-Off by PWR-BTTN (Instant-Off)**

Under ACPI (Advanced Configuration and Power management Interface) you can create a software power down. In a software power down, the system can be resumed by Wake Up Alarms. This item lets you install a software power down that is controlled by the power button on your system. If the item is set to Instant-Off, then the power button causes a software power down. If the item is set to Delay 4 Sec. then you have to hold the power button down for four seconds to cause a software power down.

**CPU THRM-Throttling (50.0%)**

Use this item to specify the CPU speed (at percentage) to slow down the CPU when it reaches the predetermined overheat temperature.

**Wake-Up by PCI Card (Enabled)**

When this item is enabled, the system power will be turned on if there is any

PCI card activity.

**Resume by Alarm (Disabled)**

When set to Enabled, additional fields become available and you can set the date (day of the month), hour, minute and second to turn on your system. When set to 0 (zero) for the day of the month, the alarm will power on your system every day at the specified time.

**\*\* Reload Global Timer Events \*\***

Global Timer (power management) events are I/O events whose occurrence can prevent the system from entering a power saving mode or can awaken the system from such a mode. In effect, the system remains alert for anything that occurs to a device that is configured as Enabled, even when the system is in a power-down mode.

**Primary/Secondary IDE 1/0 (Disabled)**

When these items are enabled, the system will restart the power-saving timeout counters when any activity is detected on any of the drives or devices on the primary or secondary IDE channels.

**FDD, COM, LPT Port (Disabled)**

When this item is enabled, the system will restart the power-saving timeout counters when any activity is detected on the floppy disk drive, serial ports, or the parallel port.

**PCI PIRQ[A-D]# (Disabled)**

When disabled, any PCI device set as the Master will not power on the system.

**PWRON After PWR-Fail (Off)**

This item enables your computer to automatically restart or return to its last operating status after power returns from a power failure.

## PNP/PCI Configuration Option

This option configures how PnP (Plug and Play) and PCI expansion cards operate in your system. Both the ISA and PCI buses on the Motherboard use system IRQs (Interrupt ReQuests) and DMAs (Direct Memory Access). You must set up the IRQ and DMA assignments correctly through the PnP/PCI Configurations Setup utility for the motherboard to work properly. Selecting PnP/PCI Configurations on the main program screen displays this menu:

CMOS Setup Utility – Copyright (C) 1984 – 2001 Award Software  
PnP/PCI Configurations

|                          |              | Item Help   |
|--------------------------|--------------|---|
| Reset Configuration Data | [Disabled]   | <b>Menu Level ▶</b><br>Default is Disabled.<br>Select Enabled to reset Extended System Configuration Data (ESCD) when you exit Setup if you have installed a new add-on and the system reconfiguration has caused such a serious conflict that the OS cannot boot |
| Resources Controlled by  | [Auto(ESCD)] |   |
| x IRQ Resources          | Press Enter  |   |
| PCI/VGA Palette Snoop    | [Disabled]   |   |
| Assign IRQ For USB       | [Enabled]    |   |
| INT Pin 1 Assignment     | [Auto]       |   |
| INT Pin 2 Assignment     | [Auto]       |   |
| INT Pin 3 Assignment     | [Auto]       |   |
| INT Pin 4 Assignment     | [Auto]       |   |
| INT Pin 5 Assignment     | [Auto]       |   |
| INT Pin 6 Assignment     | [Auto]       |   |
| INT Pin 7 Assignment     | [Auto]       |   |
| INT Pin 8 Assignment     | [Auto]       |   |

↑↓←→: Move    Enter : Select    +/-/PU/PD:Value: F10: Save    ESC: Exit    F1:General Help  
F5:Previous Values    F6:Fail-Safe Defaults    F7:Optimized Defaults

### Reset Configuration Data (Disabled)

If you enable this item and restart the system, any Plug and Play configuration data stored in the BIOS Setup is cleared from memory.

### Resources Controlled By (Auto(ESCD))

You should leave this item at the default Auto(ESCD). Under this setting, the system dynamically allocates resources to Plug and Play devices as they are required.

If you cannot get a legacy ISA (Industry Standard Architecture) expansion card to work properly, you might be able to solve the problem by changing this item to Manual, and then opening up the IRQ Resources and Memory Resources submenus.

In the IRQ Resources submenu, if you assign an IRQ to Legacy ISA, then that Interrupt Request Line is reserved for a legacy ISA expansion card. Press <Esc> to close the IRQ Resources submenu.

In the Memory Resources submenu, use the first item Reserved Memory Base to set the start address of the memory you want to reserve for the ISA expansion card. Use the second item Reserved Memory Length to set the amount of reserved memory. Press <Esc> to close the Memory Resources submenu.

### PCI/VGA Palette Snoop (Disabled)

This item is designed to overcome problems that can be caused by some non-

standard VGA cards. This board includes a built-in VGA system that does not require palette snooping so you must leave this item disabled.

**Assign IRQ For USB (Enabled)**

Names the interrupt request (IRQ) line assigned to the USB on your system. Activity of the selected IRQ always awakens the system.

**INT Pin1~8 Assignment (Auto)**

Names the interrupt request (IRQ) line assigned to a device connected to the PCI interface on your system.

**PC Health Status Option**

On motherboards that support hardware monitoring, this item lets you monitor the parameters for critical voltages, critical temperatures, and fan speeds.

CMOS Setup Utility – Copyright (C) 1984 – 2001 Award Software  
PC Health Status

|                         |            |              |
|-------------------------|------------|--------------|
| Shutdown Temperature    | [Disabled] | Item Help    |
| CPU Warning Temperature | [Disabled] |              |
| CPU Temp.               |            | Menu Level ▶ |
| CAS FAN Speed           |            |              |
| CPU FAN Speed           |            |              |
| CPU Vcore               |            |              |

↑↓→← : Move    Enter : Select    +/-/PU/PD:Value:    F10: Save    ESC: Exit    F1:General Help  
F5:Previous Values    F6:Fail-Safe Defaults    F7:Optimized Defaults

**Shutdown Temperature**

Enables you to set the maximum temperature the system can reach before powering down.

**CPU Warning Temperature**

Use this item to set the warning temperature level for the processor.

**System Component Characteristics**

These fields provide you with information about the systems current operating status. You cannot make changes to these fields.

- CPU Temperature
- CAS FAN Speed
- CPU FAN Speed
- CPU Vcore

## Frequency/Voltage Control

This item enables you to set the clock speed and system bus for your system. The clock speed and system bus are determined by the kind of processor you have installed in your system.

CMOS Setup Utility – Copyright (C) 1984 – 2001 Award Software  
Frequency/Voltage Control

|                     |            |              |
|---------------------|------------|--------------|
| CPU Clock Ratio     | [By Keyin] | Item Help    |
| Auto Detect PCI Clk | [Enabled]  | Menu Level ▶ |
| Spread Spectrum     | [Enabled]  |              |
| Async AGP/PCI /CLK  | [Disabled] |              |
| CPU Clock           | [By Keyin] |              |

↑↓→← : Move    Enter : Select    +/-/PU/PD:Value:    F10: Save    ESC: Exit    F1:General Help  
F5:Previous Values    F6:Fail-Safe Defaults    F7:Optimized Defaults

### CPU Clock Ratio

Enables you to set the CPU clock. The CPU clock ratio times the CPU Host/PCI Clock should equal the core speed of the installed processor.

#### Example:

|                                  |                   |
|----------------------------------|-------------------|
| <b>CPU Clock Ratio</b>           | 8                 |
| <b>CPU Host/PCI Clock</b>        | <u>    </u> x 100 |
| <b>Installed CPU clock speed</b> | 800 MHz           |

#### Auto Detect PCI Clk (Enabled)

When this item is enabled, BIOS will disable the clock signal of free DIMM and PCI slots.

#### Spread Spectrum (Enabled)

If you enable spread spectrum, it can significantly reduce the EMI (Electro-Magnetic Interference) generated by the system.

#### Async AGP/PCI /CLK (Disabled)

This item allows you to select the fixed clock to generate the output to AGP/PCI frequency.

#### CPU Clock (By Keyin)

Use the CPU Host Clock to set the frontside bus frequency for the installed processor (usually 133 MHz, 100 MHz or 66 MHz).

## Load Fail-Safe Defaults Option

This option opens a dialog box that lets you install fail-safe defaults for all appropriate items in the Setup Utility:

Press <Y> and then <Enter> to install the defaults. Press <N> and then <Enter> to not install the defaults. The fail-safe defaults place no great demands on the system and are generally stable. If your system is not functioning correctly, try installing the fail-safe defaults as a first step in getting your system working properly again. If you only want to install fail-safe defaults for a specific option, select and display that option, and then press <F6>.

## Load Optimized Defaults Option

This option opens a dialog box that lets you install optimized defaults for all appropriate items in the Setup Utility. Press <Y> and then <Enter> to install the defaults. Press <N> and then <Enter> to not install the defaults. The optimized defaults place demands on the system that may be greater than the performance level of the components, such as the CPU and the memory. You can cause fatal errors or instability if you install the optimized defaults when your hardware does not support them. If you only want to install setup defaults for a specific option, select and display that option, and then press <F7>.

## Set Supervisor/User Password

When this function is selected, the following message appears at the center of the screen to assist you in creating a password.

### ENTER PASSWORD

Type the password, up to eight characters, and press <Enter>. The password typed now will clear any previously entered password from CMOS memory. You will be asked to confirm the password. Type the password again and press <Enter>. You may also press <Esc> to abort the selection.

To disable password, just press <Enter> when you are prompted to enter password. A message will confirm the password being disabled. Once the password is disabled, the system will boot and you can enter BIOS Setup freely.

### PASSWORD DISABLED

If you have selected "**System**" in "Security Option" of "BIOS Features Setup" menu, you will be prompted for the password every time the system reboots or any time you try to enter BIOS Setup.

If you have selected "**Setup**" at "Security Option" from "BIOS Features Setup" menu, you will be prompted for the password only when you enter BIOS Setup.

Supervisor Password has higher priority than User Password. You can use Supervisor Password when booting the system or entering BIOS Setup to modify all settings. Also you can use User Password when booting the system or entering BIOS Setup but can not modify any setting if Supervisor Password is enabled.

## Save & Exit Setup Option

Highlight this item and press <Enter> to save the changes that you have made in the Setup Utility and exit the Setup Utility. When the Save and Exit dialog box appears, press <Y> to save and exit, or press <N> to return to the main menu:

## Exit Without Saving

Highlight this item and press <Enter> to discard any changes that you have made in the Setup Utility and exit the Setup Utility. When the Exit Without Saving dialog box appears, press <Y> to discard changes and exit, or press <N> to return to the main menu.

---

**Note:** If you have made settings that you do not want to save, use the "Exit Without Saving" item and press <Y> to discard any changes you have made.

---

This concludes Chapter 3. Refer to the next chapter for information on the software supplied with the motherboard.

## Using the Motherboard Software

---

### About the Software CD-ROM

The support software CD-ROM that is included in the motherboard package contains all the drivers and utility programs needed to properly run the bundled products. Below you can find a brief description of each software program, and the location for your motherboard version. More information on some programs is available in a README file, located in the same directory as the software.

---

**Note:** Never try to install software from a folder that is not specified for use with your motherboard.

---

Before installing any software, always inspect the folder for files named README.TXT, INSTALL.TXT, or something similar. These files may contain important information that is not included in this manual.

---

### Auto-installing under Windows 98/ME/2000/XP

The Auto-install CD-ROM makes it easy for you to install the drivers and software for your motherboard.

---

**Note:** If the Auto-install CD-ROM does not work on your system, you can still install drivers through the file manager for your OS (for example, Windows Explorer). Refer to Utility Folder Installation Notes later in this chapter.

---

The support software CD-ROM disc loads automatically under Windows 98/ME/2000/XP. When you insert the CD-ROM disc in the CD-ROM drive, the autorun feature will automatically bring up the install screen. The screen has three buttons on it, Setup, Browse CD and Exit.

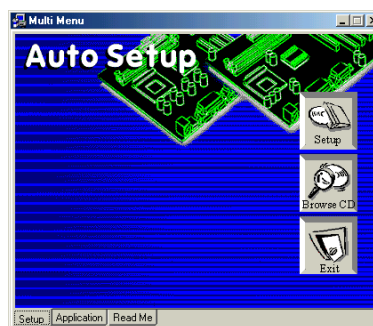

---

**Note:** If the opening screen doesn't appear, double-click the file "setup.exe" in the root directory.

---



## Setup Tab

|                  |   |
|------------------|---|
| <b>Setup</b>     | Click the <b>Setup</b> button to run the software installation program. Select from the menu which software you want to install.  |
| <b>Browse CD</b> | <p>The <b>Browse CD</b> button is the standard Windows command that allows you to open Windows Explorer and show the contents of the support CD.</p> <p>Before installing the software from Windows Explorer, look for a file named README.TXT, INSTALL.TXT or something similar. This file may contain important information to help you install the software correctly.</p> <p>Some software is installed in separate folders for different operating systems, such as DOS, WIN NT, or WIN98/95. Always go to the correct folder for the kind of OS you are using.</p> <p>To install the software, execute a file named SETUP.EXE or INSTALL.EXE by double-clicking the file and then following the instructions on the screen.</p> |
| <b>Exit</b>      | The <b>Exit</b> button closes the Auto Setup window.  |

## Application Tab

Lists the software utilities that are available on the CD.

## Read Me Tab

Displays the path for all software and drivers available on the CD.

## Running Setup

Follow these instructions to install device drivers and software for the motherboard:

1. Click **Setup**. The installation program begins:

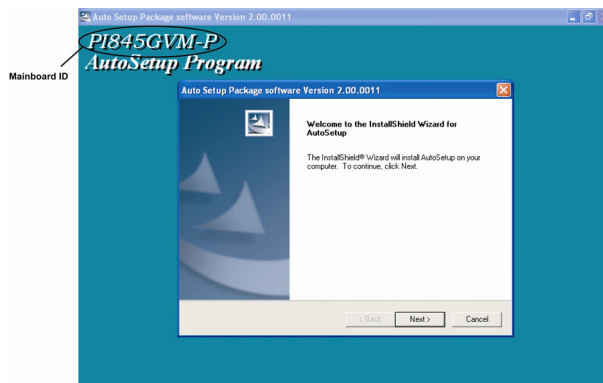

**Note:** The following screens are examples only. The screens and driver lists will be different according to the motherboard you are installing.

The motherboard identification is located in the upper left-hand corner.

2. Click **Next**. The following screen appears:

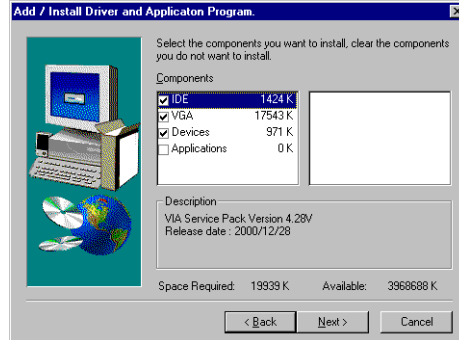

3. Check the box next to the items you want to install. The default options are recommended.
4. Click **Next** run the Installation Wizard. An item installation screen appears:

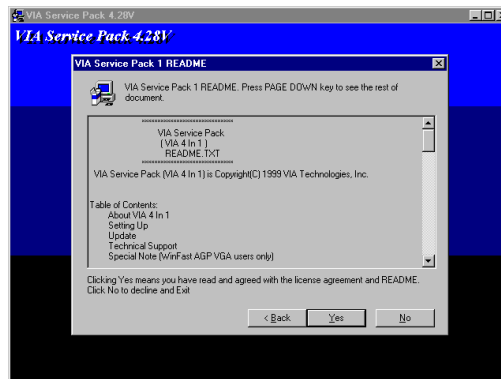

5. Follow the instructions on the screen to install the items.

Drivers and software are automatically installed in sequence. Follow the on-screen instructions, confirm commands and allow the computer to restart a few times to complete the installation.

---

## Manual Installation

Insert the CD in the CD-ROM drive and locate the PATH.DOC file in the root directory. This file contains the information needed to locate the drivers for your motherboard.

Look for the chipset and motherboard model; then browse to the directory and path to begin installing the drivers. Most drivers have a setup program (SETUP.EXE) that automatically detects your operating system before installation. Other drivers have the setup program located in the operating system subfolder.

If the driver you want to install does not have a setup program, browse to the operating system subfolder and locate the readme text file (README.TXT or README.DOC) for information on installing the driver or software for your operating system.

---

## Utility Software Reference

All the utility software available from this page is Windows compliant. They are provided only for the convenience of the customer. The following software is furnished under license and may only be used or copied in accordance with the terms of the license.

---

**Note:** These software(s) are subject to change at anytime without prior notice. Please refer to the support CD for available software.

---

### AWARD Flash Memory Utility

This utility lets you erase the system BIOS stored on a Flash Memory chip on the motherboard, and lets you copy an updated version of the BIOS to the chip. Proceed with caution when using this program. If you erase the current BIOS and fail to write a new BIOS, or write a new BIOS that is incorrect, your system will malfunction. Refer to Chapter 3, *Using BIOS* for more information.

### WinFlash Utility

The Award WinFlash utility is a Windows version of the DOS Award BIOS flash writer utility. The utility enables you to flash the system BIOS stored on a Flash Memory chip on the motherboard while in a Windows environment. This utility is currently available for WINXP\ME\2000\98SE. To install the WinFlash utility, run WINFLASH.EXE from the following directory:

\UTILITY\WINFLASH 1.51

### PC-CILLIN

The PC-CILLIN software program provides anti-virus protection for your system. This program is available for Windows 2000/ME/98SE/XP and Windows NT. Be sure to check the readme.txt and install the appropriate anti-virus software for your operating system.

We strongly recommend users to install this free anti-virus software to help protect your system against viruses.

This concludes Chapter 4.