



Installation, Start-Up and Operating Instructions

NON-PROGRAMMABLE THERMOSTATS

Cancels: New

II TSTAT-0-34
08-04

NOTE: Read the entire instruction manual before starting the installation.

This symbol → indicates a change since the last issue.

SAFETY CONSIDERATIONS

Read and follow manufacturer instructions carefully. Follow all local electrical codes during installation. All wiring must conform to local and national electrical codes. Improper wiring or installation may damage thermostat.

Recognize safety information. This is the safety-alert symbol ⚠. When you see this symbol on the equipment and in the instruction manual, be alert to the potential for personal injury.

Understand the signal words **DANGER**, **WARNING**, and **CAUTION**. These words are used with the safety-alert symbol. **DANGER identifies the most serious hazards which will result in severe personal injury or death. WARNING signifies a hazard which could result in personal injury or death. CAUTION is used to identify unsafe practices which would result in minor personal injury or product and property damage. NOTE is used to highlight suggestions which may result in enhanced installation, reliability, or operation.**

INTRODUCTION

Bryant thermostats are wall-mounted, low-voltage thermostats which maintain room temperature by controlling the operation of a heating and air conditioning system. Separate heating and cooling setpoints, plus auto changeover provide maximum comfort and flexibility. Batteries are optional; temperature and mode settings are preserved with the power off.

INSTALLATION CONSIDERATIONS

POWER

Note that all thermostats are dual powered where batteries can be installed or in the presence of R and C (24vac) are not required. 2 AA batteries are furnished with the product.

MODELS

There are 3 different models. The 9th and 10th letters of the part number indicate the model. These 2 letters also appear on the package and on the circuit board. Be sure to have the proper thermostat for the intended application. Models are:

AC — 1-stage cool, 1-stage heat for AC systems only.

HP — 1-stage cool, 2-stage heat for either HP, or AC with 2-stage heat.

2S — 2-stage cool, 2-stage heat for 2-speed AC systems, or 2-stage cool, 3-stage heat for 2-speed HP systems.

USE EACH ONLY FOR ITS INTENDED PURPOSE. SEE TABLE 1.

INSTALLATION

I. THERMOSTAT LOCATION

Thermostat should be mounted:

- Approximately 5 ft. (1.5m) from floor.

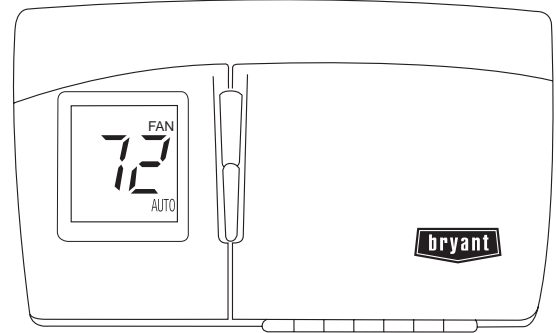

TSTATBBNAC01-C
TSTATBBNHP01-C
TSTATBBN2S01-C

A04101

HEIGHT (IN.)	WIDTH (IN.)	DEPTH (IN.)
3-1/2	5-3/4	1-3/8

Fig. 1—Bryant Non-Programmable Thermostat

- Close to or in a frequently used room, preferably on an inside partitioning wall.
- On a section of wall without pipes or duct work.

Thermostat should NOT be mounted:

- Close to a window, on an outside wall, or next to a door leading to the outside.
- Exposed to direct light and heat from a lamp, sun, fireplace, or other temperature-radiating object which may cause a false reading.
- Close to or in direct airflow from supply registers and return-air grilles.
- In areas with poor air circulation, such as behind a door or in an alcove.

II. SELECT MODEL

AC Model (1-stage cool, 1-stage heat) is to be used for single-stage heating and/or cooling applications only. It CANNOT be used with optional outdoor temperature sensor. (See Table 1.)

HP Model (1-stage cool, 2-stage heat) can be used with a single-speed heat pump (HP), or an air conditioner (AC) with a 2-stage furnace or fan coil. Software Option 5 selects HP/AC operation. This thermostat comes configured from the factory as a heat pump thermostat. Select AC in software Option 5 for AC operation. When AC operation is selected, the O/W2 terminal is converted from a reversing valve output (O) to a second-stage heat output (W2). This output can be used to control 2-stage furnaces or 2-stage electric heat in fan coils. (See Table 1.)

2S Model is for 2-speed compressor systems only (HP and AC). Output Y1 controls compressor low speed and output Y/Y2 controls compressor high speed. (See Table 1.)

TABLE 1—MODEL SELECTION AND WIRING DIAGRAM CHART

OUTDOOR UNIT	AIR CONDITIONER		HEAT PUMP	
	1 Speed	2 Speed	1 Speed	2 Speed
1-Stage Furnace	Model AC See Fig. 2		Model 2S See Fig. 8	Requires Dual Fuel Thermostat
2-Stage Furnace	Model AC See Fig. 3	Model HP See Fig. 5	Model 2S See Fig. 9	Requires Dual Fuel Thermostat
Typical Fan Coil	Model AC See Fig. 4	Model HP See Fig. 6	Model 2S See Fig. 10	Model HP See Fig. 7
Variable-Speed Fan Coil (FK4D, FV4, 40FK)	Model AC See Fig. 12	Model HP See Fig. 13	Model 2S See Fig. 14	Model HP See Fig. 15

III. INSTALL THERMOSTAT

⚠	<p>WARNING: ELECTRICAL SHOCK HAZARD Failure to follow this warning could result in personal injury or death. Before installing thermostat, turn off all power to unit. There may be more than 1 power disconnect.</p>
---	--

1. Turn OFF all power to unit.
2. If an existing thermostat is being replaced:
 - a. Remove existing thermostat from wall.
 - b. Disconnect wires from existing thermostat, 1 at a time. Be careful not to allow wires to fall back into the wall.
 - c. As each wire is disconnected, record wire color and terminal marking.
 - d. Discard or recycle old thermostat.

NOTE: Mercury is a hazardous waste and MUST be disposed of properly.

3. Open thermostat (mounting base) to expose mounting holes. The base can be removed to simplify mounting. Snap apart carefully to separate mounting base from remainder of thermostat.

NOTE: If thermostat will not separate, insert a small screwdriver into top slots for ease of opening.

4. Route thermostat wires through large hole in mounting base. Level mounting base against wall (for aesthetic value only—thermostat need not be leveled for proper operation) and mark wall through 2 mounting holes.
5. Drill two 3/16-in. mounting holes in wall where marked.
6. Secure mounting base to wall with 2 anchors and screws provided, (additional anchoring holes available for more secure mounting if needed) making sure all wires extend through hole in mounting base.
7. Adjust length and routing of each wire to reach proper terminal and connector block on mounting base with 1/4 in. extra wire. Strip only 1/4 in. insulation from each wire to prevent adjacent wires from shorting together when connected.
8. Match and connect equipment wires to proper terminals of the connector blocks. (See Table 1.)

⚠	<p>CAUTION: ELECTRICAL OPERATION HAZARD Failure to follow this caution may result in equipment damage or improper operation. Improper wiring or installation may damage the thermostat. Check to make sure wiring is correct before proceeding with installation or turning on unit.</p>
---	---

9. Push any excess wire into wall and against mounting base. Seal hole in wall to prevent air leaks. Leaks can affect operation.

10. Snap case back together.
11. Close thermostat assembly making sure pins on back of circuit board align with sockets in connector.
12. Turn ON power to unit.

NOTE: If a common wire has not been connected, two AA batteries must be used to power the thermostat.

On power up, LCD readout will display AC, HP, A2, or H2 depending on the thermostat model status. See "Power On Check" under "Operational Information" on page 11 for explanation.

IV. SET THERMOSTAT CONFIGURATION

Configuration options are intended to be selected at installation and are normally not modified by the home owner. These options are not discussed in the Homeowner's Guide and therefore must be made as part of the installation. A special procedure allows entry into the configuration mode. The thermostat will automatically exit this mode if no button is pressed for 3 minutes. While in the configuration mode, up to 14 option choices can be made:

- Option 01: Anticipator setting
- Option 02: Clean filter setting
- Option 03: Fahrenheit or Celsius selection
- Option 04: Enable fan (G) on with W/W1 output
- Option 05: HP / AC
- Option 06: Cooling Lockout (available only if an outdoor air temperature sensor is present)
- Option 07: Enable zoning
- Option 08: Auxiliary heat lockout temperature adjustment (available only on heat pump systems and if an outdoor air temperature sensor is present)
- Option 10: O (reversing valve) ON with Heat or Cool (present on Heat Pump models only)
- Option 13: Room temperature offset adjustment
- Option 15: Enable AUTO mode
- Option 18: Backlight configuration
- Option 19: Equipment Present
- Option 21: Keypad Lockout

An explanation for each of these and how to enter the configuration mode follows.

TO ENTER THE CONFIGURATION MODE:

To enter Configuration Mode, hold the FAN button down for approximately 15 seconds. After the 15 second period, Option "01" will appear in the display and the SERVICE icon will be turned on.

NOTE: If the FAN button is pressed again or if no button is pressed for 3 min, the thermostat will exit the configuration mode and return to normal operation. To reenter the configuration mode, the FAN button must be pressed and held for 15 seconds again.

WHILE IN CONFIGURATION MODE:

The display is used to show both the option number and the selection choice within that option.

A. Option 01—Anticipator Adjustment

This adjustment controls the sensitivity and cycle rate of the thermostat. Higher numbers decrease the sensitivity and slow the cycle rate. Lower numbers increase sensitivity and increase cycle

rate. However, a limiting feature will not allow more than 6 equipment cycles per hour, regardless of setting. Values can range from 1 to 9. Factory default setting is 3. This default selection will provide optimum performance in nearly all installations. Try it first. Do not change setting unless there is evidence of need to do so.

Unlike conventional anticipators, this setting is not to be determined by current draw. There is no need to measure, know, or compensate for current. There is also no droop with this thermostat, regardless of anticipator setting. This adjustment controls only sensitivity and cycle rate up to the maximum of 6 cycles per hr.

TO ADJUST:

1. Enter configuration mode (if not already there).
2. Use up and down buttons to display Option 01. The SET icon should be off.
3. Press MODE button once. The SET icon will come on. The display now shows Option 01 setting.
4. Use up and down buttons to move between the available Option 01 values of 1 to 9. Factory default is 3.
5. Press MODE button again to return to Option 01. The SET icon will now be off.
6. Use up and down buttons to select another Option, or press FAN button to exit configuration mode.

B. Option 02—Clean Filter Timer

This option selects the number of hours of blower operation (heating, cooling, or fan) before SERVICE FILTER icon is displayed. With OF selected, the icon will never come on, disabling this feature. Time selection can be from 400 to 3600 hours by selecting numbers 1 through 9. (Time is 400 X number selected.) Factory default is 2 (800 hours). Recommended selections are: disposable filter 800 hr, media filter 1200 to 1600 hr, or electronic air cleaner 1600 to 2400 hr of blower operation.

TO ADJUST:

1. Enter configuration mode (if not already there).
2. Use up and down buttons to display Option 02. The SET icon should be off.
3. Press MODE button once. The SET icon will come on. The display now shows Option 02 setting.
4. Use up and down buttons to move between the available Option 02 values of OF and 1 through 9. Factory default is 2.
5. Press MODE button again to return to Option 02. The SET icon will now be off.
6. Use up and down buttons to select another Option, or press FAN button to exit configuration mode.

C. Option 03—Fahrenheit/Celsius Selection

This option selects Fahrenheit or Celsius operation.

TO SELECT:

1. Enter configuration mode (if not already there).
2. Use up and down buttons to display Option 03. The SET icon should be off.
3. Press MODE button once. The SET icon will come on. The display now shows Option 03 setting.
4. Use up and down buttons to move between the available Option 03 choices of F (Fahrenheit) or C (Celsius). Factory default is F.
5. Press MODE button again to return to Option 03. The SET icon will now be off.
6. Use up and down buttons to select another Option, or press FAN button to exit configuration mode.

D. Option 04—G (Fan) On With W/W1 Output

This selection determines whether the G (fan) output is to be ON or OFF when any W (furnace or strip heat) output is ON. Most furnaces and fan coils manage their own blowers and do not require a separate G signal. For these applications, select OFF. Some auxiliary heaters require a separate G signal to turn on the blower. In this case, select On. Factory default is OF (off).

TO SELECT:

1. Enter configuration mode (if not already there).
2. Use up and down buttons to display Option 04. The SET icon should be off.
3. Press MODE button once. The SET icon will come on. The display now shows Option 04 setting.
4. Use up and down buttons to move between available Option 04 choices of ON or OF. Factory default is OF.
5. Press MODE button again to return to Option 04. The SET icon will now be off.
6. Use up and down buttons to select another Option, or press FAN button to exit configuration mode.

E. Option 05 — HP and 2S / AC Configuration

This configuration is available on HP and 2S models only. Selecting AC allows the installer to use an HP or 2S thermostat in an AC application.

TO SELECT:

1. Enter configuration mode (if not already there).
2. Use up and down buttons to display Option 05. The SET icon should be off.
3. Press MODE button once. The SET icon will come on. The display now shows Option 05 setting.
4. Use up and down buttons to move between available Option 05 choices of AC or HP. Factory default is HP.
5. Press MODE button again to return to Option 05. The SET icon will now be off.
6. Use up and down buttons to select another Option, or press FAN button to exit configuration mode.

F. Option 06—Cooling Lockout

An outdoor air sensor is required for this function. In OF mode, cooling is available regardless of outdoor temperature. In ON mode, cooling will not be initiated if the outdoor air temperature is below 55° F. If the compressor is already operating and the outdoor air temperature drops below 55° F, the compressor will continue to operate until the cooling cycle has completed. If the mode has been set to ON and the outdoor air sensor fails, an E3 error will be displayed.

TO SELECT:

1. Enter configuration mode (if not already there).
2. Use up and down buttons to display Option 06. The SET icon should be off.
3. Press MODE button once. The SET icon will come on. The display now shows Option 06 setting.
4. Use up and down buttons to move between available Option 06 choices of OF or ON. Factory default is OF.
5. Press MODE button again to return to Option 06. The SET icon will now be off.
6. Use up and down buttons to select another Option, or press FAN button to exit configuration mode.

G. Option 07—Zoning On/Off Configuration

This selection enables or defeats the cycle timer, the staging timer, and the compressor timeguard. (See "Operational Information" on page 11 for details.) These timers MUST be enabled (zoning OFF) for normal operation and disabled (zoning ON) for zoning applications. In zoning applications, the zone control center performs these timing functions. Factory default is OF.

TO SELECT:

1. Enter configuration mode (if not already there).
2. Use up and down buttons to display Option 07. The SET icon should be off.
3. Press MODE button once. The SET icon will come on. The display now shows Option 07 setting.
4. Use up and down buttons to move between available Option 07 choices of ON or OF. Factory default is OF.
5. Press MODE button again to return to Option 07. The SET icon will now be off.
6. Use up and down buttons to select another Option, or press FAN button to exit configuration mode.

H. Option 08—High Ambient Auxiliary Heat Lockout

Present in HP and 2S models only when configured as a heat pump. Outdoor temperature sensor **must** be attached. This selection allows lockout of any electric heat (W output) when outdoor temperature is above a selected temperature. Temperatures of 5° to 55°F (or equivalent values in C) can be selected. Feature can be disabled by selecting OFF. Emergency heat (EHEAT mode) always overrides this feature.

TO SELECT or ADJUST:

1. Enter configuration mode (if not already there).
2. Use up and down buttons to display Option 08. The SET icon should be off.
3. Press MODE button once. The SET icon will come on. The display now shows Option 08 setting.
4. Use up and down buttons to move between available Option 08 choices of OF, or 5 through 55 in 5° steps. Factory default is OF.
5. Press MODE button again to return to Option 08. The SET icon will now be off.
6. Use up and down buttons to select another Option, or press FAN button to exit configuration mode.

I. Option 10 — O (reversing valve) On with Heat or Cool Selection

This selection is only available on HP and 2S model thermostats when HP is selected via Option 05. This selection determines whether the reversing valve is energized in the heating or cooling mode. Factory default is C, energized in cooling. Use up and down buttons to change between H and C.

TO SELECT:

1. Enter configuration mode (if not already there).
2. Use up and down buttons to display Option 10.
3. Press MODE button once. The SET icon will come on. The display now shows Option 10 setting.
4. Use up and down buttons to move between available Option 10 choices of H (heat) or C (cool). Factory default is C.
5. Press MODE button again to return to Option 10. The SET icon will now be off.
6. Use up and down buttons to select another Option, or press FAN button to exit configuration mode.

J. Option 13—Room Temperature Offset

This option allows calibration (or deliberate miscalibration) of room temperature sensor. There are various reasons why the home owner may want to have displayed temperature adjusted to a higher or lower value. The selected number is the number of degrees, plus or minus, which will be added to the actual temperature. The number can range between -5 and +5. Factory

default is 0. This adjusted value will be used as actual temperature for both display and control action. For example, if 2 is selected, 72°F actual will read 74°F. If setpoint is 72, the room will control to an actual value of 70 which will be displayed and acted upon as if it were 72. The effect is that a positive number selection will make the room temperature lower and vice versa. This thermostat is factory calibrated within an accuracy of plus or minus 1°F, so this adjustment will provide the best accuracy when set to 0.

TO SELECT:

1. Enter configuration mode (if not already there).
2. Use up and down buttons to display Option 13. The SET icon should be off.
3. Press MODE button once. The SET icon will come on. The display now shows Option 13 setting.
4. Use up and down buttons to move between available Option 13 choices of -5 through +5 in 1° steps. Factory default is 0.
5. Press MODE button again to return to Option 13. The SET icon will now be off.
6. Use up and down buttons to select another Option, or press FAN button to exit configuration mode.

K. Option 15—Auto Mode On/Off Selection

This options allows the installer to enable or disable AUTO mode (automatic changeover between heat and cool). When disabled, AUTO icon does not appear when successive presses of MODE button are used to move between OFF, HEAT, and EHEAT (in heat pump systems). Factory default is ON (AUTO mode enabled).

TO SELECT:

1. Enter configuration mode (if not already there).
2. Use up and down buttons to display Option 15. The SET icon should be off.
3. Press MODE button once. The SET icon will come on. The display now shows Option 15 setting.
4. Use up and down buttons to move between available Option 15 choices of ON or OF. Factory default is ON.
5. Press MODE button again to return to Option 15. The SET icon will now be off.
6. Use up and down buttons to select another Option, or press FAN button to exit configuration mode.

L. Option 18 — Backlight Configuration

This function is only available when the thermostat is operating from full power via R and C. It is not available when the thermostat operates from batteries. In OF (off) mode, this function is disabled. The thermostat backlight will normally be off. It turns on with any button press and stays on for 10 seconds in between button presses. In ON mode, this function is enabled. The thermostat backlight will normally be on and dim in appearance. The backlight becomes brighter with any button press and remains bright for 10 seconds. Factory default is OF.

TO SELECT:

1. Enter configuration mode (if not already there).
2. Use up and down buttons to display Option 18. The SET icon should be off.
3. Press MODE button once. The SET icon will come on. The display now shows Option 18 setting.
4. Use up and down buttons to move between available Option 18 choices of ON or OF. Factory default is OF.
5. Press MODE button again to return to Option 18. The SET icon will now be off.

6. Use up and down buttons to select another Option, or press FAN button to exit configuration mode.

M. Option 19 — Equipment Present

This selection informs the thermostat of the heat, cool, and fan capabilities of the installed equipment. Select number 2, 3, or 4. Default is 4.

For equipment with both heat and cool capability and fan selection, choose 4.

For equipment with only heat or cool, but with fan selection, choose 3.

For equipment with only heat or cool and no fan selection, choose 2.

TO SELECT:

1. Enter configuration mode (if not already there).
2. Use up and down buttons to display Option 19. The SET icon should be off.
3. Press MODE button once. The SET icon will come on. The display now shows Option 19 setting.
4. Use up and down buttons to move between available Option 19 choices of 2 through 4. Factory default is 4.
5. Press MODE button again to return to Option 19. The SET icon will now be off.
6. Use up and down buttons to select another Option, or press FAN button to exit configuration mode.

N. Option 21 — Keypad Lockout

In OF (off) mode, the keypad is not locked out and has full functionality. In ON mode, the keypad is locked out and the lock icon on the display is illuminated. To unlock the keypad, the user must press and hold the up and down buttons simultaneously for approximately 5 seconds. The lock icon is turned off and the keypad will remain unlocked as long as the user presses a button at least every 30 seconds or for the entire duration of the installer test mode. If keypad remains idle for 30 seconds and the installer test mode is not in operation, the keypad will return to the locked state and the lock icon will illuminate on the screen.

TO SELECT:

1. Enter configuration mode (if not already there).
2. Use up and down buttons to display Option 21. The SET icon should be off.
3. Press MODE button once. The SET icon will come on. The display now shows Option 21 setting.
4. Use up and down buttons to move between available Option 21 choices of ON or OF. Factory default is OF.
5. Press MODE button again to return to Option 21. The SET icon will now be off.
6. Use up and down buttons to select another Option, or press FAN button to exit configuration mode.

O. Installer Test Mode

Installer test will be initiated by pressing the fan button for 20 seconds (15 seconds will enter installer setup. InS will appear on the screen and the SERVICE icon will be illuminated.

In installer test mode, pressing the MODE button will change the system operating mode. Note that AUTO mode is not available in installer test. Heating and cooling modes must be tested independently.

- a. If the mode is set to HEAT, the first stage of heating will be energized for three minutes (180 seconds), and then the first and second stages (if a second stage exists) will turn on for an additional three minutes. Installer test will always attempt to run a second stage output whether it is attached or not, providing a minimum of 6 minutes of first stage operation. At the end of the 6 minute period, the MODE will return to OFF.
- b. Pressing the FAN button while the heating or cooling equipment is not running will turn on the FAN relay and display the FAN icon.
- c. If the mode is set to COOL, the first stage of cooling turns on for three minutes, then first and second stages (if a second stage exists) will turn on for three minutes.
- d. If the mode is set to EHEAT, auxiliary heat turns on for three minutes, then the mode returns to OFF.

Terminating Installer Test

After 15 minutes of inactivity (no button presses by the installer), thermostat will automatically revert to normal operation. Pressing RESET FILTER any time during installer test will terminate installer test and return the thermostat to normal operation.

V. CHECK THERMOSTAT OPERATION

A. Fan Operation

1. Press FAN button, starting continuous fan operation. FAN icon turns on.
2. Press FAN button again, stopping fan operation. FAN icon turns off. (Some fan coils have 90 sec fan off delay, so fan may not stop immediately.)

B. Outdoor Temperature Sensor

If system is equipped with an outdoor temperature sensor, check its operation by pressing both, the temperature UP and DOWN buttons simultaneously. Outdoor temperature will be displayed for about 5 sec. If "--" is displayed, the outdoor temperature sensor is absent or not properly connected.

C. Checklist

1. Run equipment through several heating and cooling cycles to ensure proper operation.
2. If equipment is to be left in operation, set point and operating mode must be properly selected.
3. Put away tools and instruments, and clean up debris.
4. Review Homeowner's Guide with owner.
5. Leave literature packet with owner.

TABLE 2—NON-PROGRAMMABLE -C THERMOSTAT QUICK REFERENCE

THERMOSTAT OUTPUT											
TSTAT Model	Outdoor Unit	Option 5	24v Hot	Common	Fan	Heat Stage 1	Heat Stage 2	Heat Stage 3	Cool Stage 1	Cool Stage 2	Reversing Valve
AC01-C	AC	N/A	R	C	G	W/W1	N/A	N/A	Y/Y2	N/A	N/A
HP01-C	HP	OFF	R	C	G	Y/Y2	W/W1	N/A	Y/Y2	N/A	O/W2/B
HP01-C	AC	ON	R	C	G	W/W1	O/W2/B	N/A	Y/Y2	N/A	N/A
2S01-C	2-Speed AC	ON	R	C	G	W/W1	O/W2/B	N/A	Y1	Y/Y2	N/A
2S01-C	2-Speed HP	OFF	R	C	G	Y1	Y/Y2	W/W1	Y1	Y/Y2	O/W2/B

Model Numbers: TSTATBBNAC01-C, TSTATBBNHP01-C, TSTATBBN2S01-C
 Note: AC = Air Conditioner, HP = Heat Pump, 2S = 2-Speed, N/A = Not Applicable

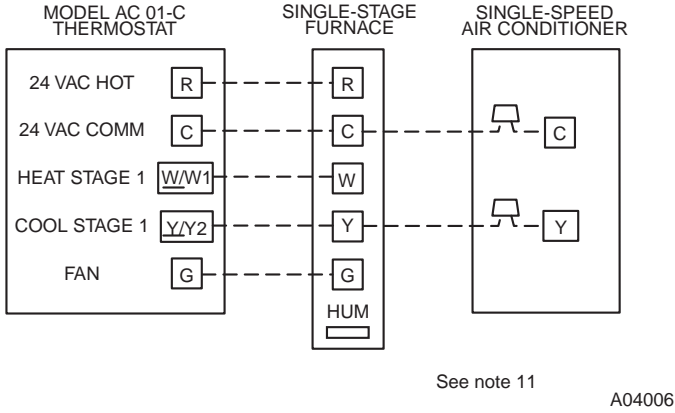

Fig. 2—Single-Speed Air Conditioner with Single-Stage Furnace

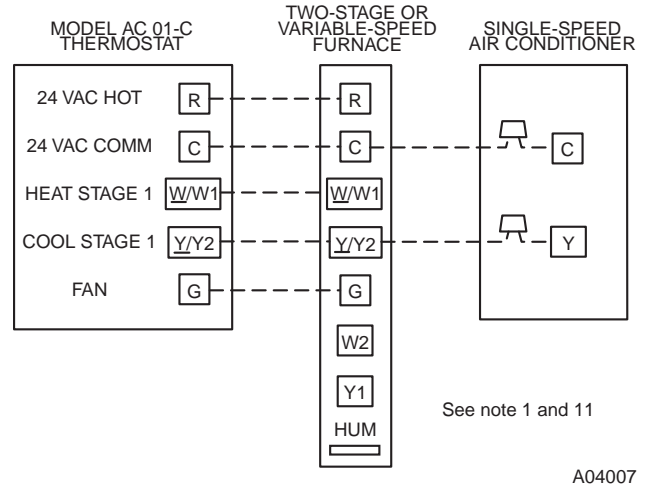

Fig. 3—Single-Speed Air Conditioner with 2-Stage or Variable-Speed Furnace

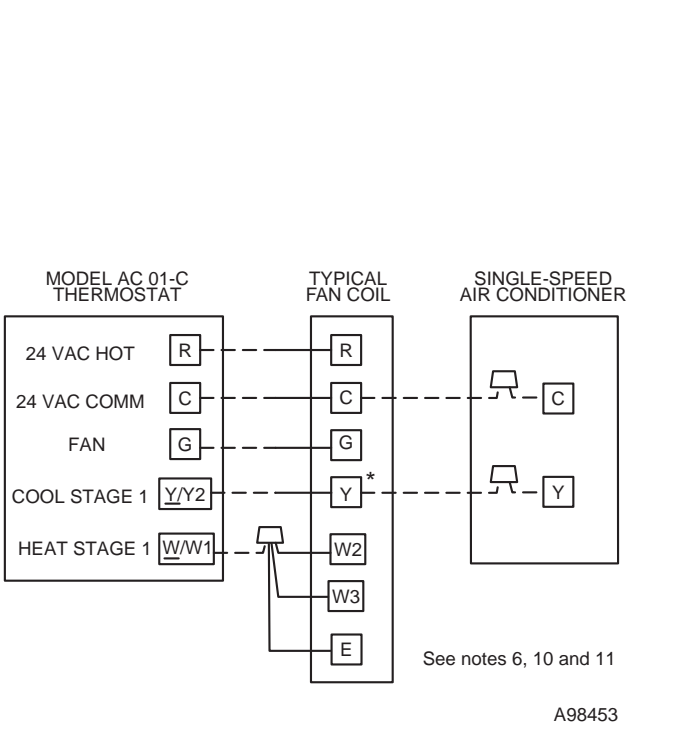

Fig. 4—Single-Speed Air Conditioner with Typical Fan Coil

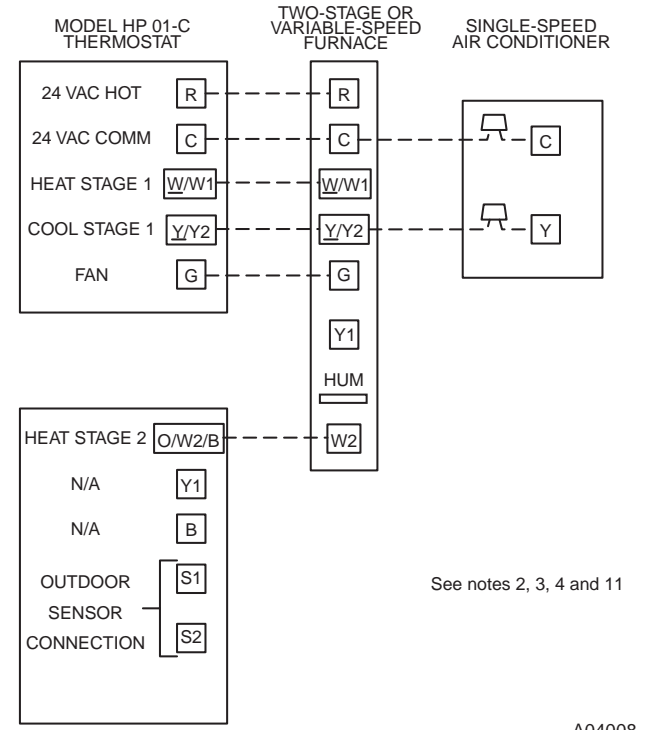

Fig. 5—Single-Speed Air Conditioner with 2-Stage or Variable-Speed Furnace

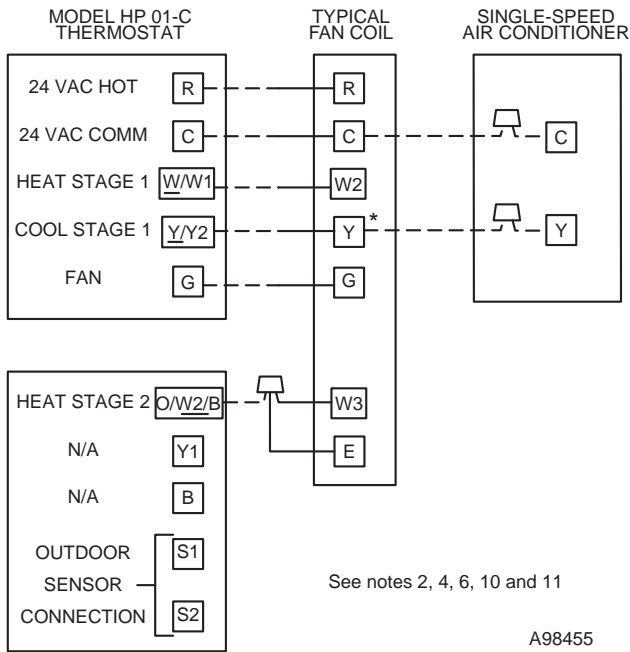

Fig. 6—Single-Speed Air Conditioner with Typical Fan Coil

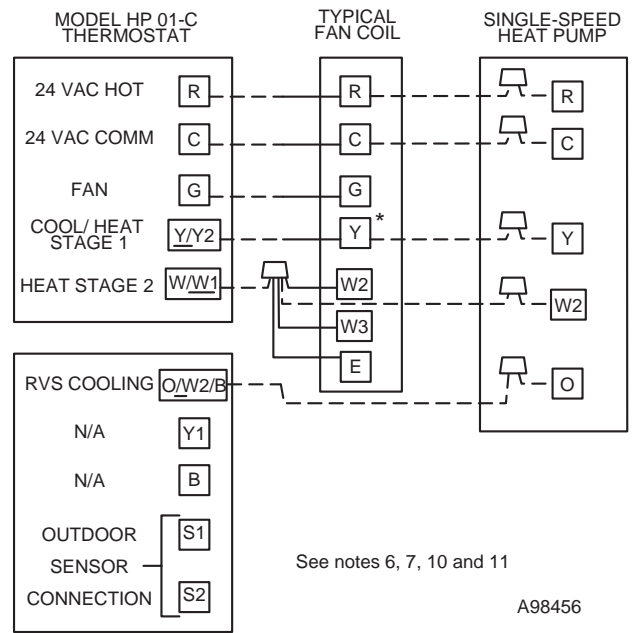

Fig. 7—Single-Speed Heat Pump with Typical Fan Coil

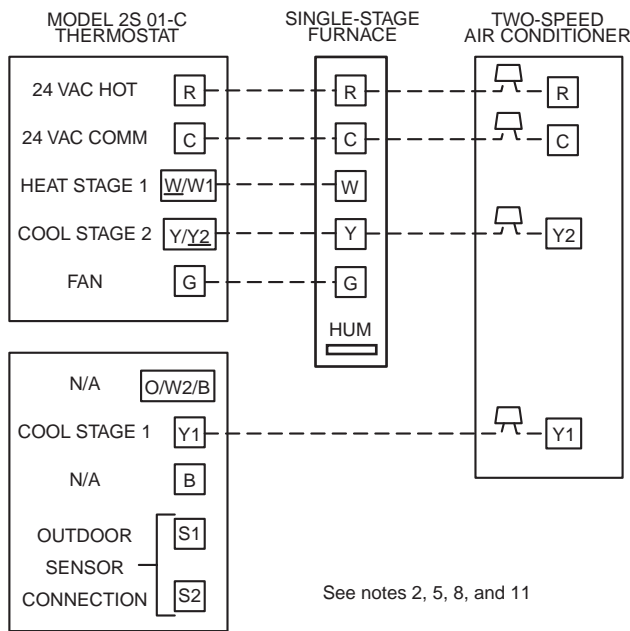

Fig. 8—Two-Speed Air Conditioner with Single-Stage Furnace

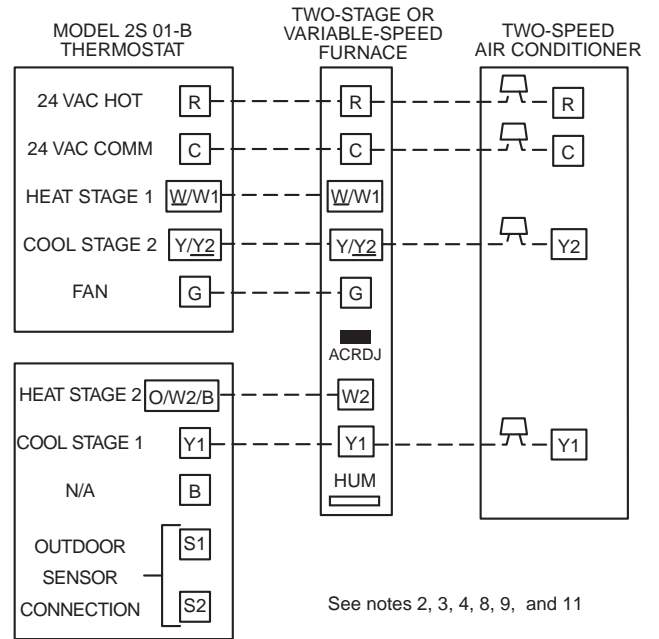

Fig. 9—Two-Speed Air Conditioner with 2-Stage or Variable-Speed Furnace

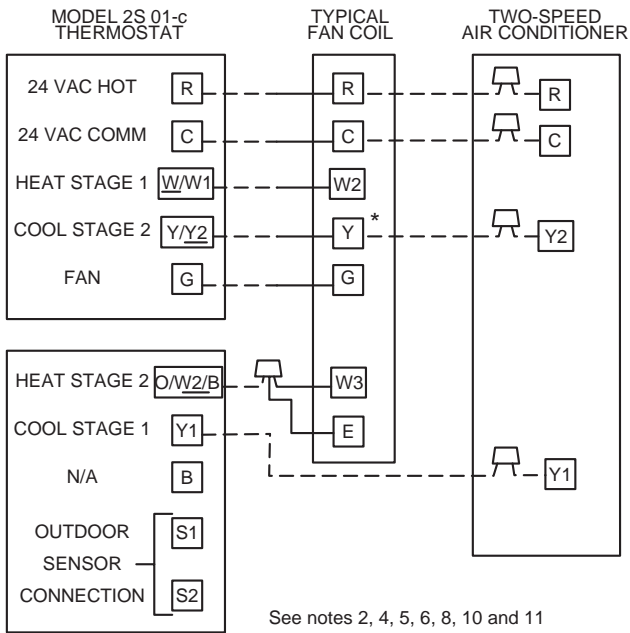

Fig. 10—Two-Speed Air Conditioner with Typical Fan Coil A98459

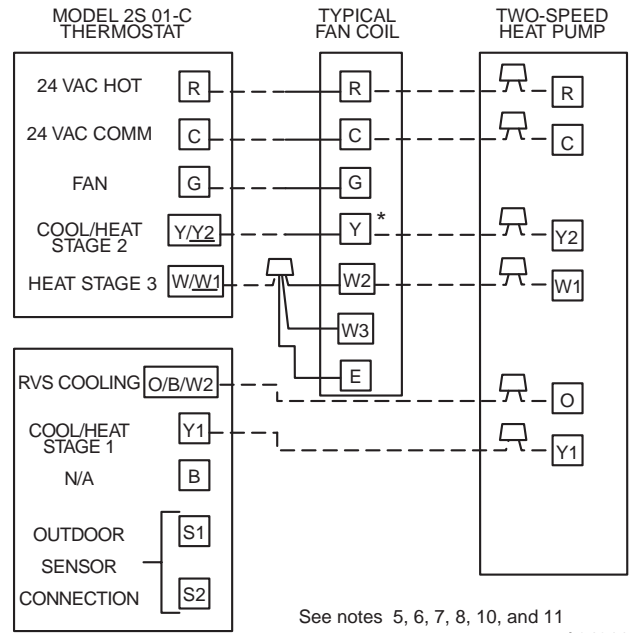

Fig. 11—Two-Speed Heat Pump with Typical Fan Coil A04011

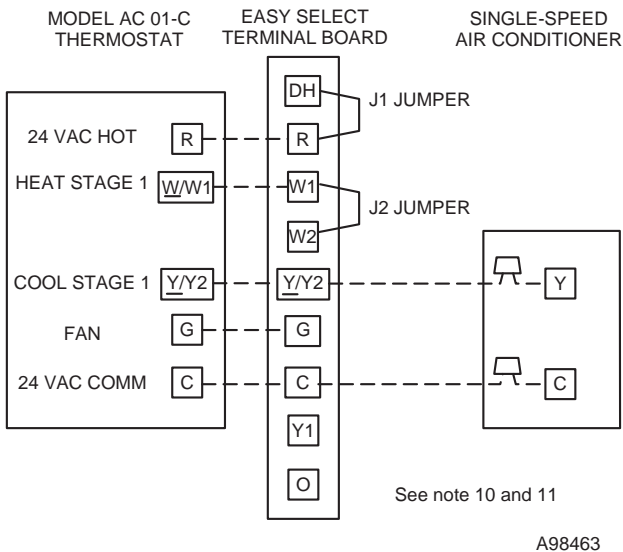

Fig. 12—Single-Speed Air Conditioner with Variable Speed (FK4D, FV, 40FK) Fan Coil

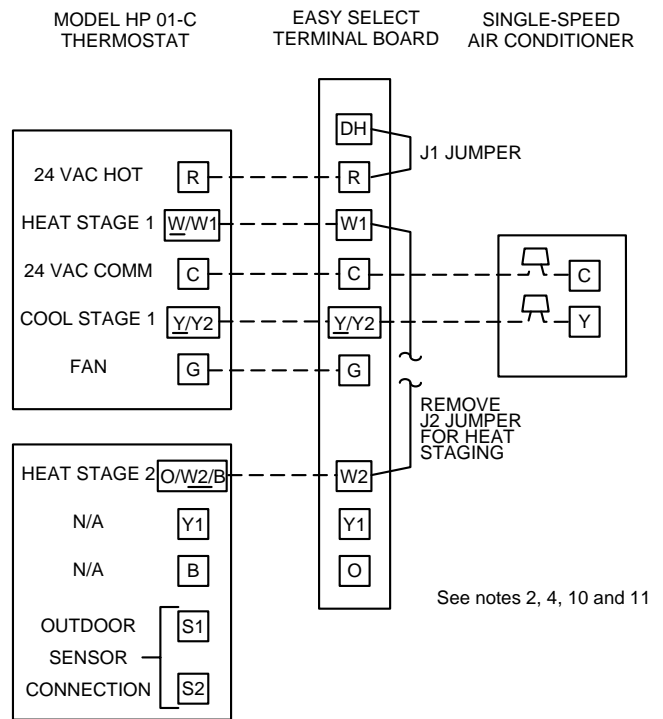

Fig. 13—Single-Speed Air Conditioner with Variable-Speed (FK4D, FV, 40FK) Fan Coil

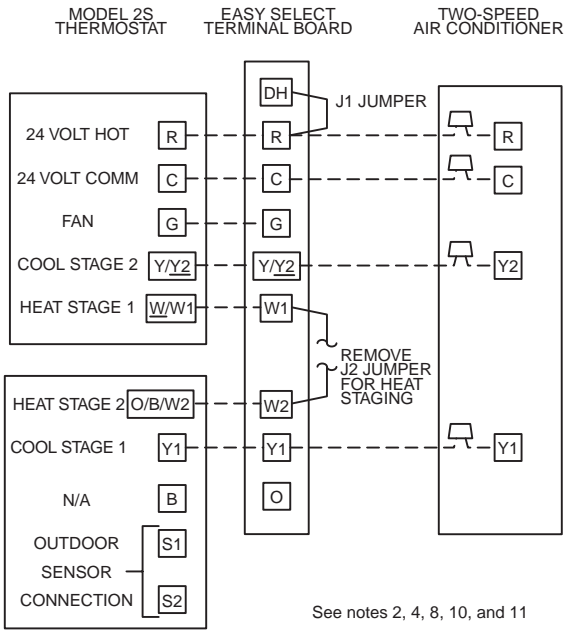

Fig. 14—Two-Speed Air Conditioner with Variable-Speed (FK4D, FV4, 40FK) Fan Coil

A04012

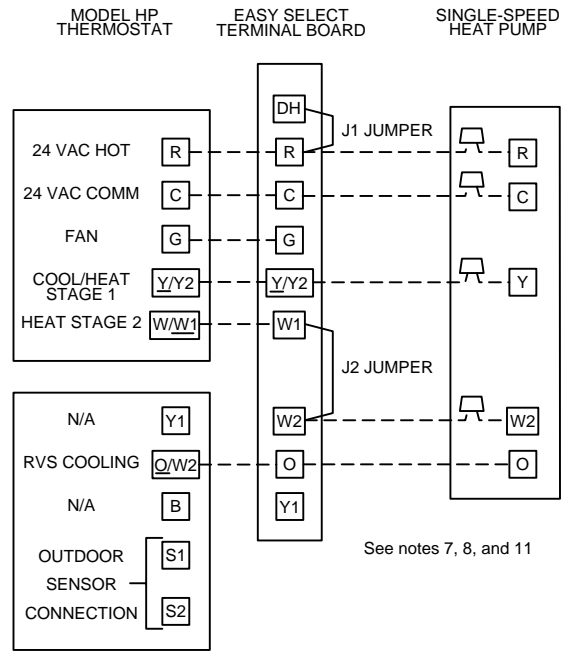

Fig. 15—Single-Speed Heat Pump with Variable-Speed (FK4D, FV4, 40FK) Fan Coil

A98466

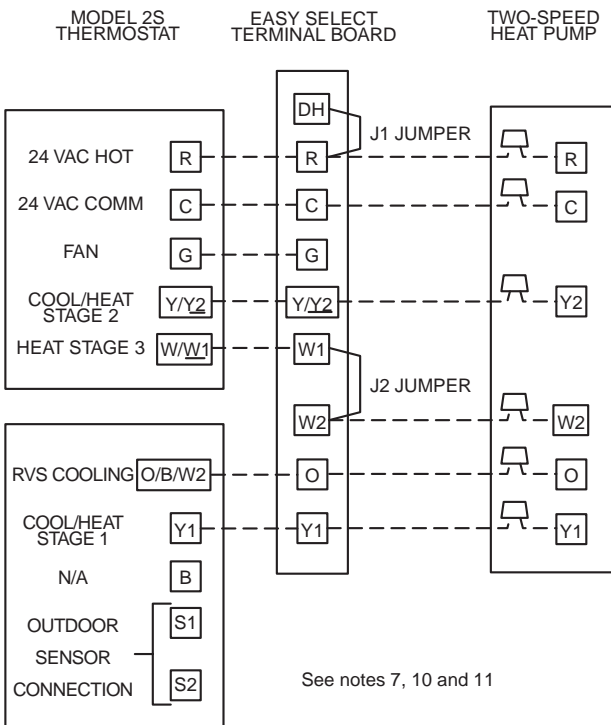

Fig. 16 — Two-Speed Heat Pump with Variable-Speed (FK4D, FV4) Fan Coil

A04013

WIRING DIAGRAM NOTES:

1. Furnace must control its own second-stage heat operation via furnace control algorithm. Refer to indoor equipment Installation Instructions for proper setup.
2. See Option 5 information to convert HP and 2S thermostats to AC thermostat operation.
3. As an option, lock the furnace into low-heat operation and let O/W2/B control high-heat operation. Refer to indoor equipment Installation Instructions for proper setup.
4. O/W2/B can control second-stage heat. Refer to indoor equipment Installation Instructions for proper setup.
5. Refer to outdoor equipment Installation Instructions for latent kit requirements (if any).
6. Terminals marked with * may not be present on equipment.
7. O/W2/B energizes reversing valve in cooling or heating. See Option 10.
8. Refer to outdoor equipment Installation Instructions for proper setup.
9. If system is wired per diagram, the ACRDJ (jumper) on furnace control board should be removed to allow thermostat to control outdoor unit staging.
10. Refer to fan coil Installation Instructions for proper wiring.
11. If batteries are installed, C (common wire) is not required between indoor unit and thermostat.

OPERATIONAL INFORMATION

FIVE-MINUTE COMPRESSOR TIMEGUARD

This timer prevents the compressor from starting unless it has been off for at least 5 minutes. It can be defeated for 1 cycle by simultaneously pressing the FAN mode button and the INCREASE TEMPERATURE button.

FIFTEEN-MINUTE CYCLE TIMER

This timer prevents the start of a heating or cooling cycle until at least 15 minutes after the last start of the same cycle. Its function is to assure that equipment is not cycled more than 4 times per hr. This timer is defeated for 1 cycle when the desired temperature is manually changed. It can also be defeated for 1 cycle by simultaneously pressing the FAN mode button and the INCREASE TEMPERATURE button.

FIFTEEN-MINUTE STAGING TIMER

In multistage heating or cooling, this timer prevents any higher stage from turning on until the preceding stage has been on for 15 minutes. This timer is defeated if the temperature error is greater than 5°F (usually due to a large change in desired temperature).

THREE-MINUTE MINIMUM ON TIME

In normal operation, when a stage turns on, it will not turn off for a minimum of 3 minutes.

HEAT/COOL SET POINTS (DESIRED TEMPERATURES)

A minimum difference of 2°F is enforced between heating and cooling set points. This is done by allowing one setting to "push" the other, to maintain this difference.

AUTO CHANGEOVER

When the auto changeover mode is selected, a change from heat to cool (or vice versa) will not occur until an opposite mode demand has existed for 20 minutes. If the set point is changed, the 20 minute requirement is deleted. Auto mode may be disabled.

EMERGENCY HEAT MODE

When thermostat is configured as a heat pump and emergency heat mode is selected, all Y signals are locked out and W becomes energized upon a call for heat.

HEAT ON AND COOL ON ICONS

When a heating or cooling demand exists, the HEAT ON or COOL ON icon will either remain on or flash. If flashing, the equipment is temporarily prevented from turning on by one of the timers (see above). While the icon remains on without flashing, the equipment is on.

POWER ON CHECK

When AC power is first applied, all segments of the display are turned on for a few sec. Following this, the temperature display indicates the model/configuration via the following 2 digit code:

AC—1-speed air conditioner, HP—1-speed heat pump, A2—2-speed air conditioner, H2—2-speed heat pump.

ERROR CODES

-- — If the thermostat cannot properly read room temperature, the display will indicate -- (2 dashes) and all outputs (except the fan if on) will turn off. This is to prevent operation of the equipment if the thermostat has failed.

E2 — If the AC line voltage drops below a minimum (brownout) level, all outputs are turned off and the display indicates E2. This condition will remain for 15 sec after proper line voltage is restored. If the AC line voltage disappears completely, the display will immediately go blank.

E3 — If the thermostat cannot properly read outdoor temperature, and it is needed for proper operation (Heat pump system and Option 8 is not set to OF), E3 will flash alternately with room temperature.

THERMOSTAT TROUBLESHOOTING

SYMPTOM	WHAT TO CHECK
Blank LCD	Check for 24vac between R and C at terminal connections or battery.
"--" (2 dashes) on temperature display	Temperature sensor reading out of range. Check sensor for damage. If recycling power does not clear display, thermostat should be replaced.
"E2" on temperature display	Brownout condition or too low of voltage to thermostat. Double check wiring and check for 24vac between R and C. E2 will clear 15 sec after proper voltage is restored.
"E3" on temperature display	The outdoor temperature sensor is open, not connected, or shorted.
"SERVICE FILTER" on temperature display	After the selected number of hour of blower operation "FILTER" will display on LCD. This is to remind the home owner to "check" the filter. Press RESET FILTER button to clear display and reset timer to 0.
Cooling will not come on	Select COOL mode. Set desired temperature to 10°F below room temperature. Simultaneously press FAN and INCREASE TEMPERATURE buttons to defeat timers. Check for COOL ON icon and 24vac at Y (first-stage) terminal. If present, thermostat is OK and problem is with equipment or wiring. If not present, replace thermostat.
Heating will not come on	Select HEAT mode. Set desired temperature to 10°F above room temperature. Simultaneously press FAN and INCREASE TEMPERATURE buttons to defeat timers. Check for HEAT ON and 24vac at Y (first-stage) terminal (with heat pump) or W/W1 (with air conditioner) terminal. If present, thermostat is OK and problem is with equipment or wiring. If not present, replace thermostat.

NON-PROGRAMMABLE THERMOSTAT CONFIGURATION RECORD

Date _____

Owner/Operator _____ Thermostat Model No. _____

A) Hardware Configuration

_____ Seal hole in wall.

B) Mode Settings

_____ Mode (Off, Heat, Cool, Auto, Eheat)

_____ Heating Set Point Value

_____ Cooling Set Point Value

_____ Fan (Auto or On)

C) Configuration Options

- 1 _____ Anticipator (1-9: factory default = 3)
- 2 _____ Clean Filter Timer (Off or 1-9: factory default = 2)
- 3 _____ Fahrenheit or Celsius (F or C: factory default = F)
- 4 _____ Fan On with W/W1 output (Off or On: factory default = Off)
- 5 _____ HP (2-speed) / AC Configuration
- 6 _____ Cooling Lockout (Off or On: factory default = Off)
- 7 _____ Zoning Selection (Off or On: factory default = Off)
- 8 _____ Auxiliary Heat Lockout (Off or 5-55°F: factory default = Off)
- 9 _____ N/A
- 10 _____ O(Reversing Valve) ON with Heat or Cool (present on Heat Pump models only.)
- 11-12 _____ N/A
- 13 _____ Room Temperature Offset (-5 to +5: factory default = 0)
- 14 _____ N/A
- 15 _____ Enable Auto Mode (Off or On: factory default = On)
- 16-17 _____ N/A
- 18 _____ Backlight Configuration: (On = Continuous; Off = Backlight with Keypress; Default = Off)
- 19 _____ Equipment Present (2, 3, 4); Default = 4
- 20 _____ N/A
- 21 _____ Keypad lockout (Off or On: Default = Off)

A04105