



## Series S . S40-CR

### Chronometer, time counter

PANEL METERS

*Chronometer and time counter, in compact size 72x36 mm, and standard 14 mm digit height. Configurable with up and down counting modes. Independent controls for start, stop and reset. Display modes in decimal format and sexagesimal (clock) format. Reading with 4 digit display. Fast access to alarm setpoints, special modes for counting exceeded time and totalized counting times, 'on power up' function, configurable led brightness. Universal AC and DC power. Up to 2 optional modules for output and control (relays, analog outputs, Modbus RTU communications, RS-485 ASCII, RS-232, ...).*

[www.fema.es](http://www.fema.es)

Tel. (+34) 93.729.6004 [info@fema.es](mailto:info@fema.es)

# 1. Panel meter S40-CR

## Chronometer and time counter, in compact 72x36 mm size

Panel meter in compact 72 x 36 mm size with 14 mm digit height, and function chronometer and time counter. Time displayed in different formats covering hours, minutes, seconds and days. Reading configurable in decimal and sexagesimal (clock) formats. Up and down counting functions, with configurable preset value.

### Controls

Independent controls for 'start', 'stop' and 'reset' (see section 1.6). Controls activated by default through free potential contacts. Configurable for activation with other control signals (NPN, PNP, inductive, ...).

### Reset

Reset control is provided by connection at the rear of the instrument, configurable to activate by edge or by level. Front reset configurable at the 'LE' keypad (see section 1.7). Automatic reset configurable when reaching an alarm setpoint (see section 1.7).

### Special functions

Special functions with activation by connection at the rear of the instrument. Includes control for counting direction, total accumulated times, total exceeded time, hold of display reading and memory of cycles (see section 1.12.2).

### Alarms

Independent alarms configurable as maximum or minimum, with configurable activation and deactivation delays and optional inverted activation of the relay. Alarms configurable in 'normal' mode or 'repeat' mode. In 'repeat' mode the alarm activates every time the configured setpoint time has passed (see section 1.12.4).

The 'on\_alarm' parameter allows to associated a predefined function to the activation of the alarm. Available functions are : stop counting, activate the reset, set reading to '0' or continue. Use 'on\_alarm' configured to 'reset' to implement repetitive cycles of time which can be counted by special function 'B.2' (see section 1.12.2).

### Flash

Several options allow to configure the display flash in case of 'stop' or 'start' counting, or in case of alarm activation (see section 1.12.4).

### Security on start-up

The 'On power-up' function defines a time of inactivity of the instrument after power-up, the status of the instrument ('start' or 'stop') after power-up, and the option to apply a reset after power-up (see section 1.12.2).

### Memory

The instrument saves and recovers the last reading value in case of power-loss.

### Configurable 'fast-access' menu

The front key 'UP' (▲) gives access to a user configurable menu with direct access to several useful functions such as alarm setpoints and/or preset value (see section 1.12.5).

### Control and retransmission options

Options for signal retransmission and control with 1 and 2 relays, analog outputs isolated, communications in Modbus RTU, RS-485 ASCII and RS-232. Special options with 4 relay outputs (see section 2).

### Mechanical

Front protection IP54. Connections by plug-in screw terminals. For industrial applications.

## 1.1 How to order

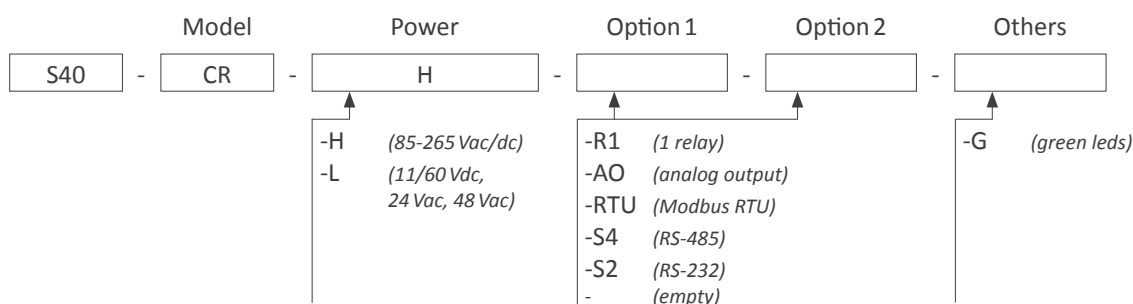

# Index

1. Panel meter S40-CR . . . . .	2	1.13 Full configuration menu . . . . .	14
1.1 How to order . . . . .	2	1.14 Factory configuration . . . . .	16
1.2 Included functions . . . . .	4	1.15 Application example 1 . . . . .	17
1.3 Power connections . . . . .	4	1.16 Application example 2 . . . . .	17
1.4 Front view . . . . .	4	1.17 To access the instrument . . . . .	18
1.5 Rear view . . . . .	4	1.18 Modular system . . . . .	18
1.6 Control connections . . . . .	5	1.19 Precautions on installation . . . . .	19
1.7 Types of reset . . . . .	5	1.20 Warranty . . . . .	19
1.8 Technical specifications . . . . .	6	1.21 CE declaration of conformity . . . . .	19
1.9 Mechanical dimensions (mm) . . . . .	6	2. Output and control modules . . . . .	20
1.10 How to operate the menus . . . . .	7	2.1 Module R1 . . . . .	20
1.11 Messages and errors . . . . .	7	2.2 Module AO . . . . .	20
1.12 Configuration menu . . . . .	8	2.3 Module RTU . . . . .	21
1.12.1 Initial set-up . . . . .	8	2.4 Module S4 . . . . .	21
1.12.2 Configuration . . . . .	8	2.5 Module S2 . . . . .	22
1.12.3 Controls configuration . . . . .	10	2.6 Modules R2, R4 . . . . .	22
1.12.4 Alarms . . . . .	11	3. Accessories . . . . .	23
1.12.5 Fast access . . . . .	12	3.1 Option G . . . . .	23
1.12.6 Super fast access . . . . .	13	4. Other options . . . . .	23
1.12.7 Menu 'Key LE' . . . . .	13	4.1 Adapter KA72 . . . . .	23
1.12.8 Left zeros . . . . .	13		
1.12.9 Function 'Password' . . . . .	13		
1.12.10 Factory reset . . . . .	13		
1.12.11 Firmware version . . . . .	13		
1.12.12 Brightness . . . . .	13		
1.12.13 Access to optional modules . . . . .	13		

## 1.2 Included functions

Functions included		Section
Fast access	yes, configurable	1.12.5
Preset	yes, configurable	1.12.1
Reset	yes, configurable : front, rear and/or linked to alarm activation	1.7
Counting direction	up or down	1.12.1
Memory	yes, recovers at power-up	
Functions 'on alarm'	yes	1.12.4
Special functions	control up / down cycle counter accumulated counter exceeded counter hold control memory for 'shorter cycle' and 'longer cycle'	1.12.2
'On Power Up'	yes	1.12.2
Password	blocks configuration	1.12.9
Alarms	activation delay deactivation delay inverted relay locked deactivation	1.12.4
Display brightness	5 levels	1.12.12

Table 1 - Functions included

## 1.3 Power connections

Earth connection - Although a terminal is provided for earth connection, this connection is optional. The instrument does not need earth connection for correct operation nor for compliance with the security regulations.

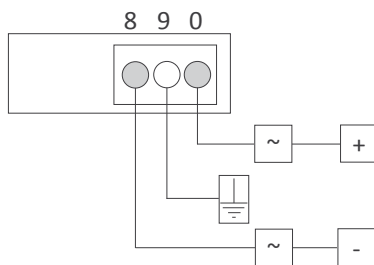

Fuse - To comply with security regulation 61010-1, add to the power line a protection fuse acting as disconnection element, easily accessible to the operator and identified as a protection device.

- Power 'H'      fuse 250 mA time lag
- Power 'L'      fuse 400 mA time lag

## 1.4 Front view

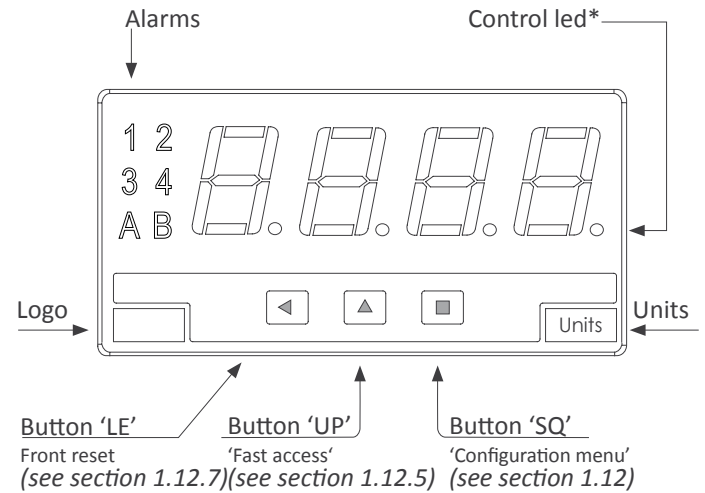

\* The 'led control' is operative only in counting modes that do not display seconds or tenths of second. It flashes 'on' and 'off' at a rate of 1 second when instrument is counting ('start'). It remains 'off' when the instrument is not counting ('stop').

## 1.5 Rear view

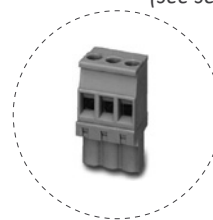
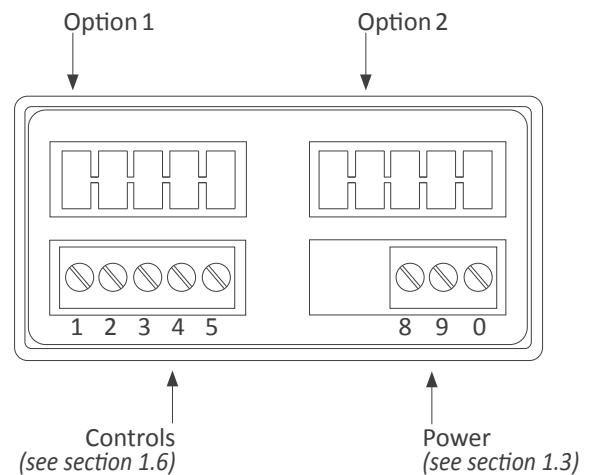

Detail of the plug-in screw terminals provided with the instrument. The instrument is provided with all terminals needed, both male and female.

## 1.6 Control connections

- Normal connections ('con.a') - controls for 'start', 'stop' and 'reset' are independent. Activation by default is by falling edge (by short-circuit to the 0Vdc terminal). Internal pull-up resistors are activated. This is the normal working mode.

To work with other control signals or activations, configure the internal pull-up/pull-down resistors, the trigger level and the activation by rising or falling edge (see section 1.12.3).

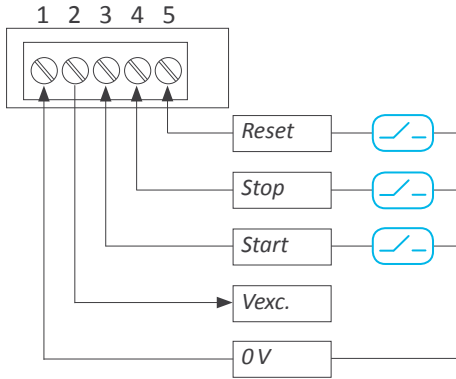

- Alternative connections ('con.b') - the 'start' and 'stop' controls share the same terminal '1'. Terminal '1' at high level activates the 'start'. Terminal '1' at low level activates the 'stop'. The 'reset' control is independent at terminal 5. Terminal '3' is now dedicated to activate signal 'B'. See section 1.12.2 for more information on functions associated to the activation of the 'B' signal. Activating on the configuration menu a 'B' function, automatically activates the 'alternative connections' mode.

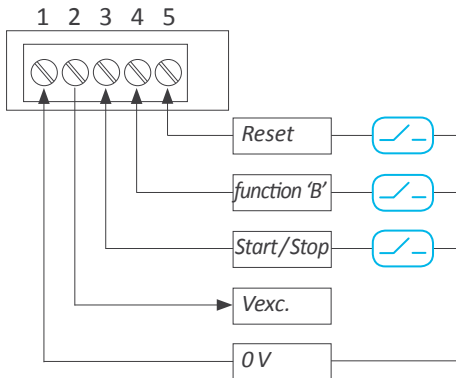

## 1.7 Types of reset

The reset function can be activated from three independent and configurable sources:

- Front reset - associated to the front button 'LE' (◀). This reset can be disabled by menu (see section 1.12.7). The front reset is activated by levels (pressed / not pressed).
- Rear reset - connected to pin 5 at the rear terminal. It activates by default on falling edge, by connection to the 0Vdc terminal. Activation is configurable (see section 1.12.2) by edge (falling or rising) or level (up or down). Trigger level is configurable between 0 and 3.9Vdc. Internal configurable pull-up / pull-down resistors allow to use other type of sensors (NPN, PNP, push-pull, inductives, TTL, ...).
- Alarm reset - alarms 1 and 2 can be configured to activate a certain function (a reset for example) when alarm activates (see section 1.12.4). This configuration creates infinite loops which can be counted by using function 'B.2 cycles' (see section 1.12.2).

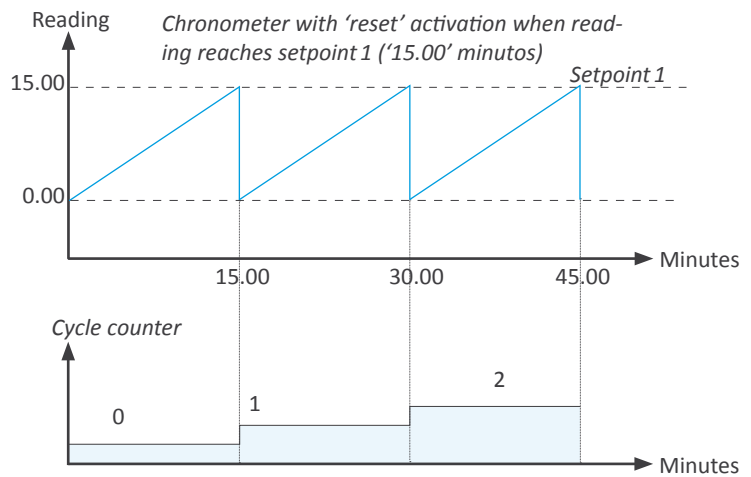

## 1.8 Technical specifications

### Digits

number of digits	4
led	7 segments led
color	red or green
digit height	14 mm

### Reading modes

\* Meaning : (d=days, h=hours, m=minutes, s=seconds, c=cents of second)

Sexagesimal reading modes		
	mm.ss	
	hh.mm	
	dd.hh	

Decimal reading modes		
ssss	mmmm	hhhh
sss.s	mmm.m	hhh.h
ss.ss	mm.mm	hh.hh

maximum reading	99.59 / 99.23 / 9999
minimum reading	-19.59 / -19.23 / -1999

<b>Accuracy of the quartz</b>	±0.01 %
<b>Thermal drift</b>	20 ppm / °C

<b>Controls</b>	start, stop, reset
default signal	free potential contact
configurable for ...	NPN, PNP, Namur, pick-up, TTL, inductive, mechanical, ...

maximum Vdc on terminals	±30 Vdc
excitation voltage	configurable +18 Vdc, +15 Vdc, +9 Vdc, +5 Vdc
maximum current	70 mA
protection	yes, current limited to 70 mA

<b>Display refresj</b>	12 refresh/second
retention memory	yes, recovers counting value in case of power-loss

### Power

power 'H'	85 to 265 Vac/dc
power 'L'	11 to 60 Vdc and 24/48 Vac
isolation*	2500 Veff with power 'H' 1500 Veff with power 'L' *tested during 60 seconds.

consumption	<1.5 W only meter <4.0 W meter with options
-------------	--

<b>Configuration</b>	3 buttons front keypad
----------------------	------------------------

<b>Front protection</b>	IP54
-------------------------	------

<b>Output and control options</b>	relays, analog outputs, serial communications (see section 2)
-----------------------------------	---

### Mechanical

mounting	panel
connections	plug-in screw terminal
housing material	ABS, polycarbonate (V0)
weight	<150 grams
front size	72x36 mm
panel cut-out	69x32.5 mm
depth from panel	98 mm (including terminals)

### Temperature

operation	from 0 to +50 °C
storage	from -20 to +70 °C
warm-up time	15 minutes

## 1.9 Mechanical dimensions (mm)

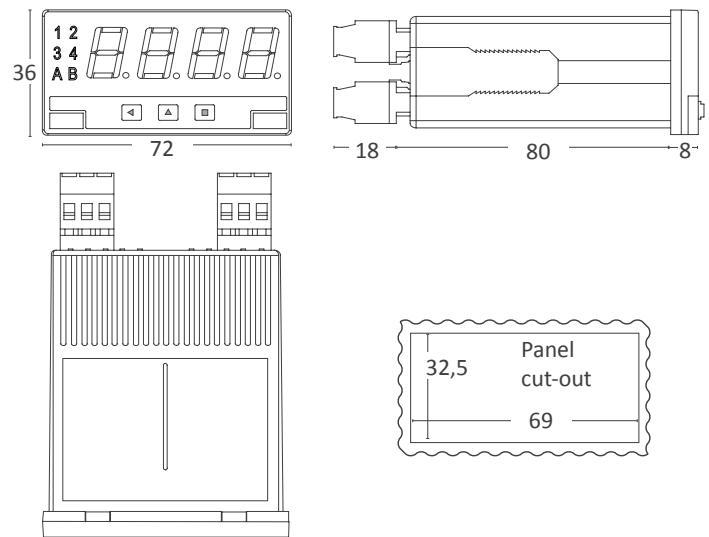

## 1.10 How to operate the menus

The instrument has two menus accessible to the user :

'Configuration menu' (key SQ) (■)

'Fast access' menu (key UP) (▲)

### Configuration menu

The 'configuration menu' modifies the configuration parameters to adapt the instrument to the application needs. To access the 'configuration menu' press for 1 second the SQ (■) key. This access can be blocked by activating the 'Password' ('PASS') function. While operating the 'configuration menu', the alarm status is 'hold' to the status they had before accessing the menu, and the output and control modules remain in 'error' state. When leaving the 'configuration menu', the instrument applies a system reset, followed by a brief disconnection of the alarms and the output and control modules. Functionality is then recovered.

For a detailed explanation on the 'configuration menu' see section 1.12, and for a full view of the 'configuration menu' structure see section 1.13.

### 'Fast access' menu

The 'fast access' menu is an operator configurable menu, providing fast and direct access to the most usual functions of the instrument with a single key pad stroke. Press key UP (▲) to access this menu.

See section 1.12.5 for a list of functions eligible for 'fast access' in this instrument. The 'Password' ('PASS') function does not block access to this menu. Accessing and modifying parameters in the 'fast access' menu does not interfere with the normal functionality of the instrument, and it does not generate any system reset when validating the changes.

### Front key pad description

**Key SQ (■)** - press the SQ (■) key for 1 second to access the 'configuration menu'. Inside the menu, the SQ (■) key functions as a 'ENTER' key. It selects and accesses the menu option currently displayed. At menus with numerical value entries, it validates the number displayed.

**Key UP (▲)** - the UP (▲) key gives access to the 'fast access' menu. Inside the menus, it moves vertically through the different menu options. At menus with numerical value entries, it modifies the digit selected by increasing its value to 0, 1, 2, 3, 4, 5, 6, 7, 8, 9.

**Key LE (◀)** - inside the menus, the LE (◀) key functions as the 'ESCAPE' key. It leaves the selected menu, and eventually, will leave the whole menu. When leaving the 'configuration menu' with the LE (◀) key, the changed parameters are activated. At menus with numerical value entries, the LE (◀) key allows to select the active digit. To modify the value of the selected digit use the UP (▲) key.

### Menu 'rollback'

After 30 seconds without interaction from the operator, the instrument will rollback and leave the 'configuration menu' or the 'fast access' menu. All changes will be discarded.

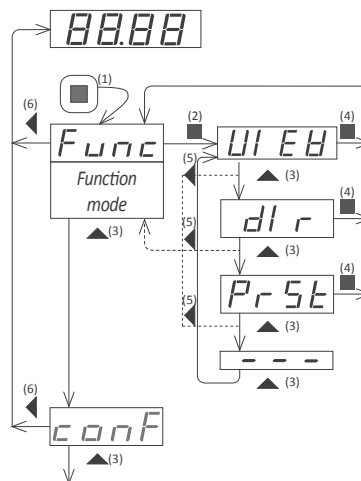

Example of operation inside the 'configuration menu'.

1. The SQ (■) key enters into the 'configuration menu'.
2. The SQ (■) key enters into the 'Func' option menu.
3. The UP (▲) key moves through the menu options.
4. The SQ (■) key selects the desired range and returns to the 'Func' menu.
5. The LE (◀) key leaves the actual menu level and moves to the previous menu level.
6. The LE (◀) key leaves the 'configuration menu'. Changes are applied and saved at this moment.

## 1.11 Messages and errors

The error messages are shown on display in flash mode.

Messages and errors	
'Err.1'	incorrect password.
'Err.2'	at 'oPt.X' menu entry. Installed module is not recognized.
'Err.8'	excitation voltage overload.
'9999'	+ flashing mode. Reading is in overrange.
'-1999'	+ flashing mode. Reading is in underrange.

Table 2 - Messages and error codes

## 1.12 Configuration menu

Press 'SQ' (■) for 1 second to access the 'configuration menu'. For a description on how to operate inside the menus see section 1.10. For a full vision of the 'configuration menu' structure see section 1.13.

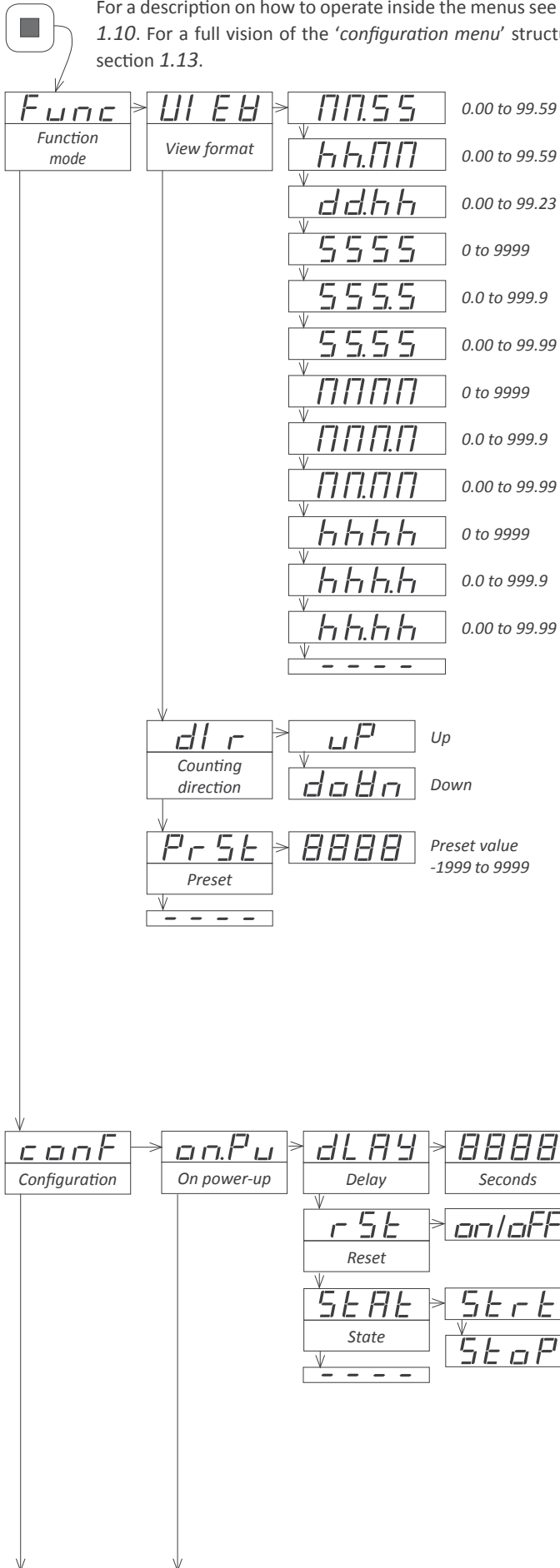

### 1.12.1 Initial set-up

To configure the initial set up of the instrument, select the viewing format, configure the up or down counting mode and assign the pre-set value.

Enter the 'Function mode' ('Func') menu and select the 'View' format desired.

- 'MM.SS' - clock format, minutes and seconds.
- 'hh.MM' - clock format, hours and minutes.
- 'dd.hh' - clock format, days and hours.
- 'SSSS' - counter of seconds.
- 'SSS.S' - counter of seconds with one decimal.
- 'SS.SS' - counter of seconds with two decimals.
- 'MMMM' - counter of minutes.
- 'MMM.M' - counter of minutes with one decimal.
- 'MM.MM' - counter of minutes with two decimal.
- 'hhhh' - counter of hours.
- 'hhh.h' - counter of hours with one decimal.
- 'hh.hh' - counter of hours with two decimal.

Access the 'Counting direction' ('dlr') and select 'uP' for up counting or 'doWn' for down counting.

At the 'Preset' ('PrSt') menu select the preset value. The preset value will load on display when reset function activates. See section 1.7 for a description on the different activation modes for the reset.

### 1.12.2 Configuration

Additional configuration parameters for the instrument.

The 'On Power Up' ('on.Pu') menu configures functions to apply at start-up. It applies only to instrument restart after power loss. It does not apply to instrument restart due to change in configuration.

• parameter 'Delay' ('dLay') assigns a waiting time in seconds. The instrument waits the configured time before starting normal function. During this waiting time, the display shows all decimal points on in flash mode, all alarms are in 'off' state, there is no signal acquisition and there is no communications or control being performed. After the configured time is over, the instrument starts in normal function.

*Application - the start-up process for an automation system implies that different parts of the system (engines, actuators, controllers, ...) have different start-up times. The 'Delay' function gives time to the instrument to wait until the slowest part of the system is fully functional before executing actions on the system (signal reading, relay activation, ...).*

• the 'Reset' ('rSt') parameter will execute a reset of the counter each time the instrument is restarted.



## 1.12 Configuration menu (cont.)

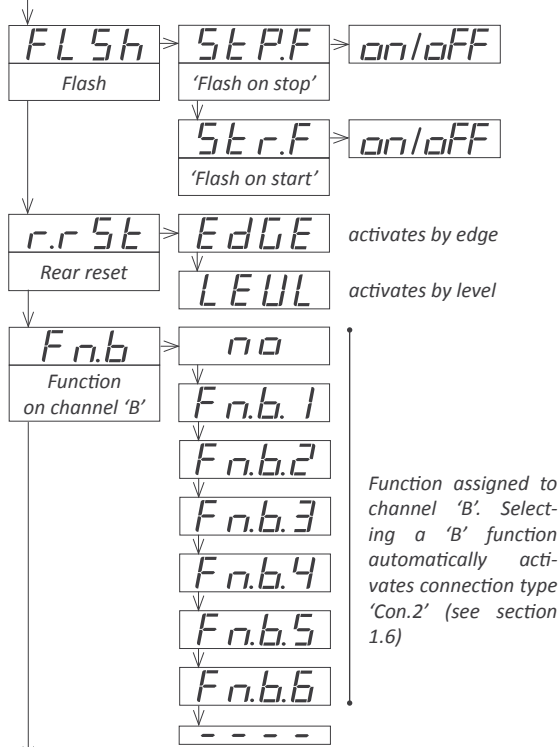

Next menu entry gives access to the configuration parameters of the 'channel B function' ('Fn.b') previously selected. If no function has been selected, menu entry indicates 'Fn.b.n'. Following is an explanation for menus 'Fn.b.1' to 'Fn.b.6'.

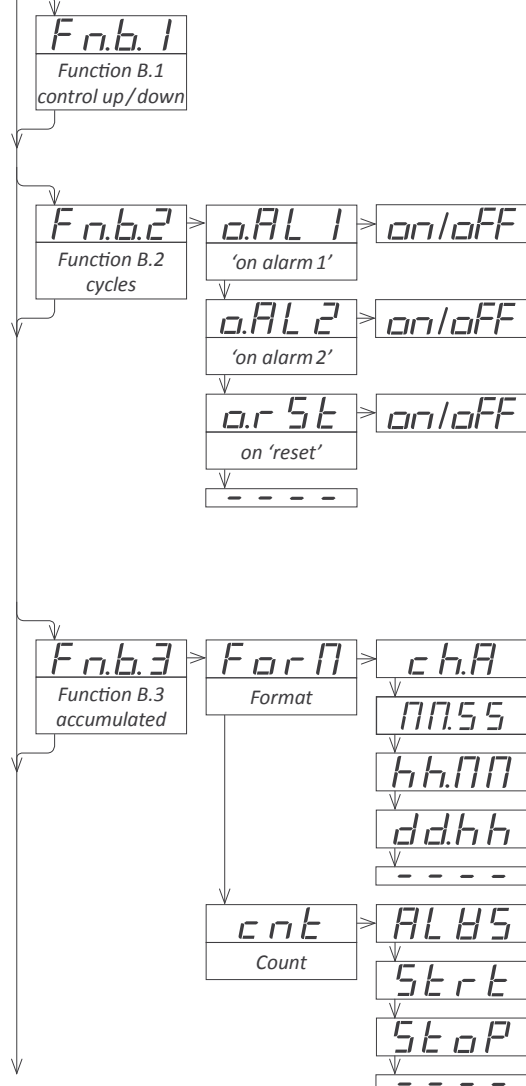

- the 'State' ('StAt') parameter controls the state of the counter after power-up. Select 'Strt' to count after power-up or 'StoP' to remain stopped after power-up.

The whole power-up process of the instrument is explained as follows : instrument waits the time defined at 'Delay', it then resets (or not) the counter according to parameter 'Reset', then it counts (or remains stopped according to parameter 'StAt' and then it checks for external controls 'start', 'stop' and 'reset'.

The 'Flash' menu ('FLSh') controls the activation of the rear reset by edge ('EdGE') or by level ('LEVL').

The 'Rear reset' menu ('r.rSt') controls the activation of the display flashing when instrument is stopped ('StP.F') and / or when instrument is counting ('StP.F').

The 'Function on channel B' menu ('Fn.b') controls the activation of special functions on channel 'B' (rear terminal 4). If a 'B' function is selected, signal connections change to 'alternative connections' as indicated at section 1.6.

Following is an explanation for each of the 6 'B functions' available.

- function 'B.1 control up/down' ('Fn.b.1') controls the up or down counting based on the state of input signal at channel 'B'.

- function 'B.2 cycles' ('Fn.b.2') enables an internal counter (from 0 to 9999) which can be made visible on display by activation of channel 'B' signal. There are several events that can add '+1' to this internal counter :

- 'on alarm 1' ('o.AL1') select 'on' to add '+1' each time alarm 1 activates.
- 'on alarm 2' ('o.AL2') select 'on' to add '+1' each time alarm 2 activates.
- 'on reset' ('o.rSt') select 'on' to add '+1' each time reset function activates.

- function 'B.3 accumulated' ('Fn.b.3') enables an internal counter which can be made visible on display by activation of channel 'B' signal. To reset the accumulated counter, view the counter on display and activate the reset (front or rear). The accumulated counter counts the totalized time that the instrument has been counting or stopped (needs to be powered-up).

- parameter 'Format' ('ForM') configures the view format for the accumulated counter. Value 'ch.A' views in same format as the main instrument.

- at parameter 'Count' ('cnt') select 'ALWS' to count the total time that the instrument has been powered. Select 'Strt' to count the total time the instrument has been counting. Select 'StoP' to count the total time the instrument has been stopped.

## 1.12 Configuration menu (cont.)

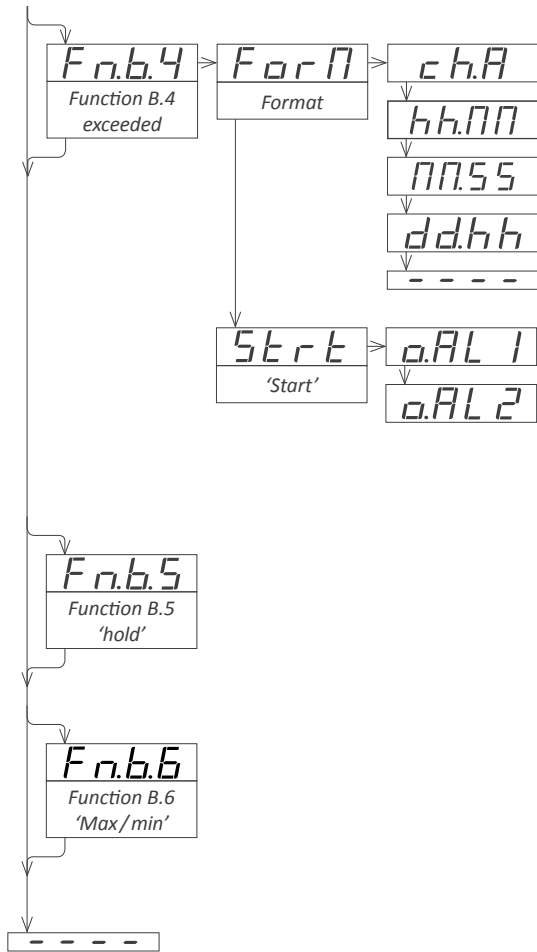

- function **'B.4 exceeded'** (**'Fn.b.4'**) enables an internal counter for exceeded time, which can be made visible on display by activation of channel 'B' signal. To reset the exceeded counter, view the counter on display and activate the reset (front or rear). The reset leaves the exceeded counter at a value of '0' and in 'Stop' mode. The exceeded counter counts the totalized time after a certain event triggers the start of the internal counter.

- at the **'Start'** (**'Strt'**) parameter select **'o.AL1'** to start the exceeded counter when alarm 1 activates. Select **'o.AL2'** to trigger the counter on activation of alarm 2.

- parameter **'Format'** (**'ForM'**) configures the view format for the exceeded counter. Value **'ch.A'** views in same format as the main instrument.

- function **'B.5 hold'** (**'Fn.b.5'**) controls the hold of the display by controlling the state of the signal at channel 'B'. The chronometer continues counting on the background.

- function **'B.6 max/min'** (**'Fn.b.6'**) internally saves the maximum and minimum times recorded of a certain cycle. Each time a reset is activated, the instrument compares the actual reading value with the previous saved memorized values. It replaces the minimum value if the actual value is smaller. It replaces the maximum value if the actual value is larger. Minimum and maximum values are visible through front key UP (▲) (see section 1.12.5).

*Application - a production process executes a reset signal each time a production element has been finished. At the end of the day, the maximum and minimum production times can be accessed.*

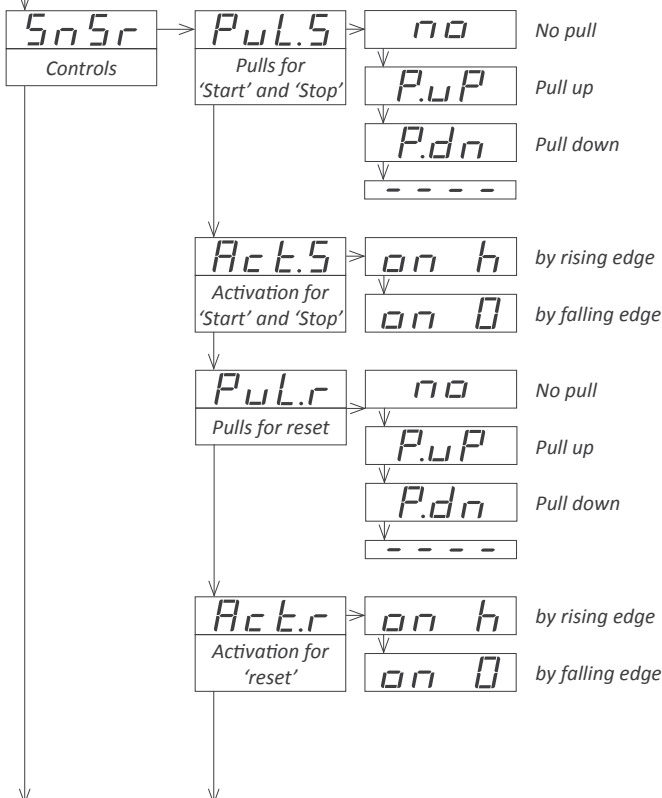

### 1.12.3 Controls configuration

The **'Controls'** configuration menu (**'SnSr'**) provides configuration for the 'start', 'stop' and 'reset' controls. Default configuration is activation by free potential contacts, with activation by falling edge (direct connection to terminal 0 Vdc). The following parameters allow to configure the instrument controls to work with other type of signals (NPN, PNP, inductives, ...).

- 'Pulls for Start and Stop'** (**'PuL.S'**) - select **'P.uP'** to activate pull-up resistors (needed for NPN sensors). Select **'P.dn'** to activate pull-down resistors (needed for PNP sensors). Select **'no'** to deactivate pulls. Selecting a pull resistors configures the trigger level to 2,5Vdc.

- 'Activation for Start and Stop'** (**'Act.S'**) - select (**'on\_h'**) to activate the 'Start' and 'Stop' controls by rising edge. Select (**'on\_0'**) to activate by falling edge.

- 'Pulls for reset'** (**'PuL.r'**) - select **'P.uP'** to activate pull-up resistors (needed for NPN sensors). Select **'P.dn'** to activate pull-down resistors (needed for NPN sensors). Select **'no'** to deactivate pulls. Selecting a pull resistors configures the trigger level to 2,5Vdc.

- 'Activation for Reset'** (**'Act.r'**) - select (**'on\_h'**) to activate the 'Reset' control by rising edge. Select (**'on\_0'**) to activate by falling edge. Additionally, reset signal can be configured to activate by levels instead of edges (see section 1.12.2). In case of activation by levels

## 1.12 Configuration menu (cont.)

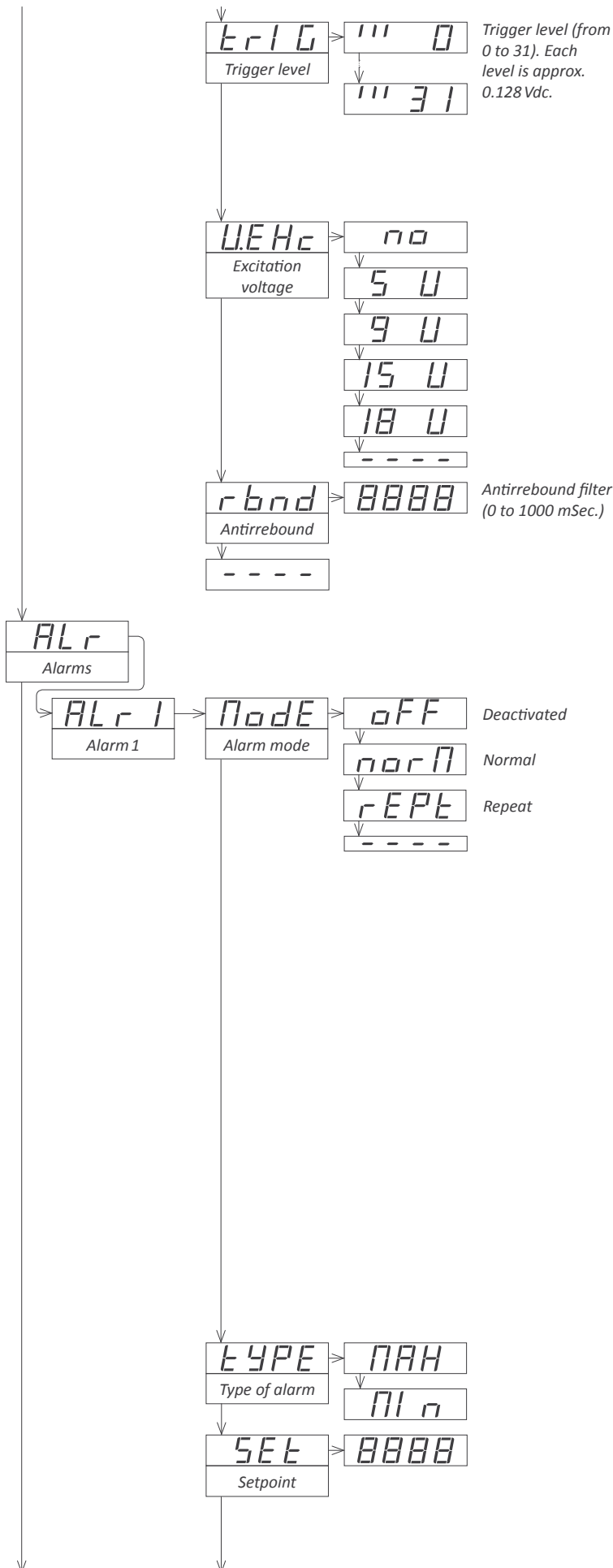

els, value 'on\_h' activates the reset on high signal value, and value 'on\_0' activates reset on low signal. Front reset activates always by state.

- **'Trigger level' ('trIG')** - select the signal voltage level at which the instrument will consider that the signal has reached the activation level. Selectable from 0 to 31 levels, where each level is approximately 0.128 Vdc. Trigger level is the same for channels 'start' and 'stop'. Reset channel has a fixed trigger to 2,5 Vdc. The three leds to the left of the value reflect the state ('0' or '1') of control channels 'Start', 'Stop' and 'Reset'.

- **'Excitation voltage' ('VExc')** - power provided by the instrument to power-up the sensors (if needed) used to control the signals 'start', 'stop' and / or 'reset', or to be used as an active signal ('1') for special connections. Select the for the excitation voltage at 5 Vdc, 9 Vdc, 15 Vdc or 18 Vdc. Select 'no' to disable the excitation voltage.

- **'Antirrebound filter' ('rbnd')** - Value between 0mSeconds and 1000 mSeconds. when a signal is received, detection of additional signals is inhibited for the time defined in this parameter. Recommended value for a mechanical contact sensor is 100 mSeconds. Applies to 'start', 'stop' and 'reset' signals.

### 1.12.4 Alarms

The **'Alarms' ('ALr')** menu configures the independent activation of up to 2 relay outputs, installed with the R1 optional modules (see section 2.1). For outputs up to 4 relays, see special modules R2, R4 and R6 at section 2.6. The alarm states are indicated in the front display with leds marked as '1' and '2'. To configure an alarm, enter into the alarm menu (**'ALr1'** or **'ALr2'**) and configure the following parameters :

- parameter **'Alarm mode' ('Mode')** allows to disable the alarm (**'oFF'**) or to select between two working modes :

- in **'normal' mode ('norM')** the alarm has a setpoint configured, that activates when the display reading reaches the setpoint value. It can be configured as a 'maximum alarm' or 'minimum alarm'. Provides configuration for independent activation and deactivation delays, flash control and action selection on activation.

- in **'repeat' mode ('rEPt')** the alarm activates each time that the chronometer reaches a multiple of the setpoint. Alarm remains active during the time indicated at parameter **'deactivation delay' ('dEL.1')**. Other parameters on the **'Alarm'** menu have no effect in this mode. This mode is not functional in viewing modes with tenths of second or cents of second.

*Application : chronometer in 'mm.ss' mode with a'repeat' alarm and setpoint 1 at '15.00'. Alarm activates at '15.00', '30.00', '45.00', etc.*

- at **'Alarm type' ('TYPE')** select the alarm to act as a maximum type alarm (**'MAX'**) or a minimum type alarm (**'Min'**). The maximum type alarm (or minimum type alarm) activates when the display value is higher (or lower) than the setpoint value.

- at **'Setpoint' ('SEt')** enter the value for the alarm activation point. This parameter is eligible for configuration through the **'Fast access'** menu (see section 1.12.5).

## 1.12 Configuration menu (cont.)

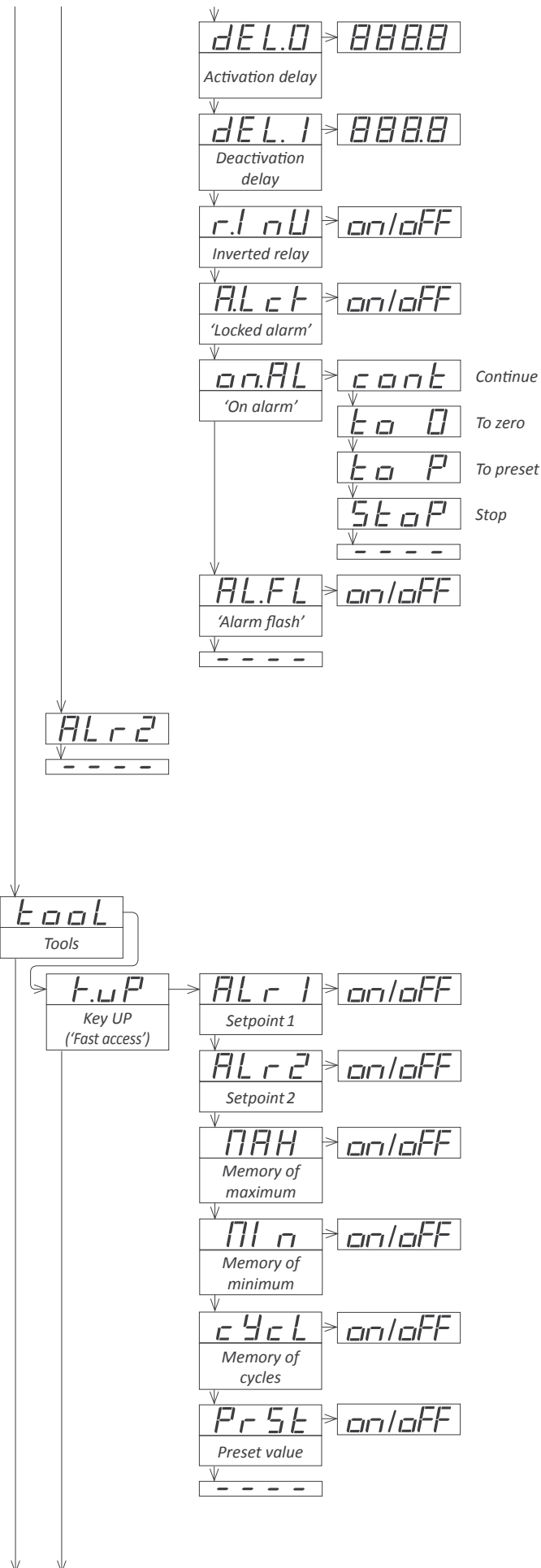

- at **'Activation delay' ('dEL.0')** configure the delay to apply before alarm activation. The activation delay starts counting when the setpoint value is passed. Value from 0.0 to 99.9 seconds.
- at **'Deactivation delay' ('dEL.1')** configure the delay to apply before alarm deactivation. The deactivation delay starts counting when the setpoint value plus the hysteresis value, is passed. Value from 0.0 to 99.9 seconds.
- the **'Relay inverted' ('r.Inv')** parameter inverts the normal relay connections. When set to **'on'** the relay will be active when alarm is inactive. For security applications where an inactive relay controls the shutdown of the system.
- the **'Locked alarm' ('A.Lck')** parameter disables the automatic deactivation of the alarm. Alarm deactivation must be performed manually, by pressing the 'LE' front button (see section 1.12.7)
- the **'On alarm' ('on.AL')** parameter assigns a predefined behavior when alarm activates.
  - select **'cont'** to continue counting.
  - select **'to\_0'** to load '0' on displays Parameter **'deactivation delay' ('dEL.1')** automatically configures to 1 second.
  - select **'to\_p'** to load preset value on display. Parameter **'deactivation delay' ('dEL.1')** automatically configures to 1 second.
  - select **'stop'** to stop the counting.
- set the **'Alarm flash' ('AL.FL')** parameter to **'on'** to activate the flash of the display when alarm is active. To manually deactivate the flash mode, press any of the front keys or change the state of any of the control signals 'start', 'stop' or 'reset'.

### 1.12.5 Fast access

The 'UP' (▲) key at the front of the instrument gives access to a list of functions configurable by the operator. See section 1.10 for an explanation on how to operate the 'fast access' menu.

The **'Key UP (Fast access)' ('K.uP')** menu allows to select which functions will be accessible through the 'fast access' menu. Select **'on'** to activate each function.

- the **'Setpoint 1' ('ALr1')** function allows to visualize and modify the alarm 1 setpoint through the 'fast access' menu.
- the **'Setpoint 2' ('ALr2')** function allows to visualize and modify the alarm 2 setpoint through the 'fast access' menu.
- the **'Memory of maximum' ('MAX')** or **'Memory of minimum' ('MIN')** functions allow to visualize the maximum or minimum reading value stored in memory. To reset this value, visualize the memory value at the 'fast access' menu with key UP (▲) and when message **'rSt'** is displayed, press (■) to reset.
- the **'Memory of cycles' ('cYcL')** function allow to visualize and reset the memory of cycles. To reset this value, visualize the memory value at the 'fast access' menu with key UP (▲) and when message **'rSt'** is displayed, press (■) to reset. The memory of cycles counts '+1' each time a reset alarm occurs ('on\_AL' / 'to\_0' or 'to\_P') or a reset by 'overrange' / 'underrange' occurs.
- the **'Preset value' ('PrSt')** function allows to visualize and modify the preset value configured.

## 1.12 Configuration menu (cont.)

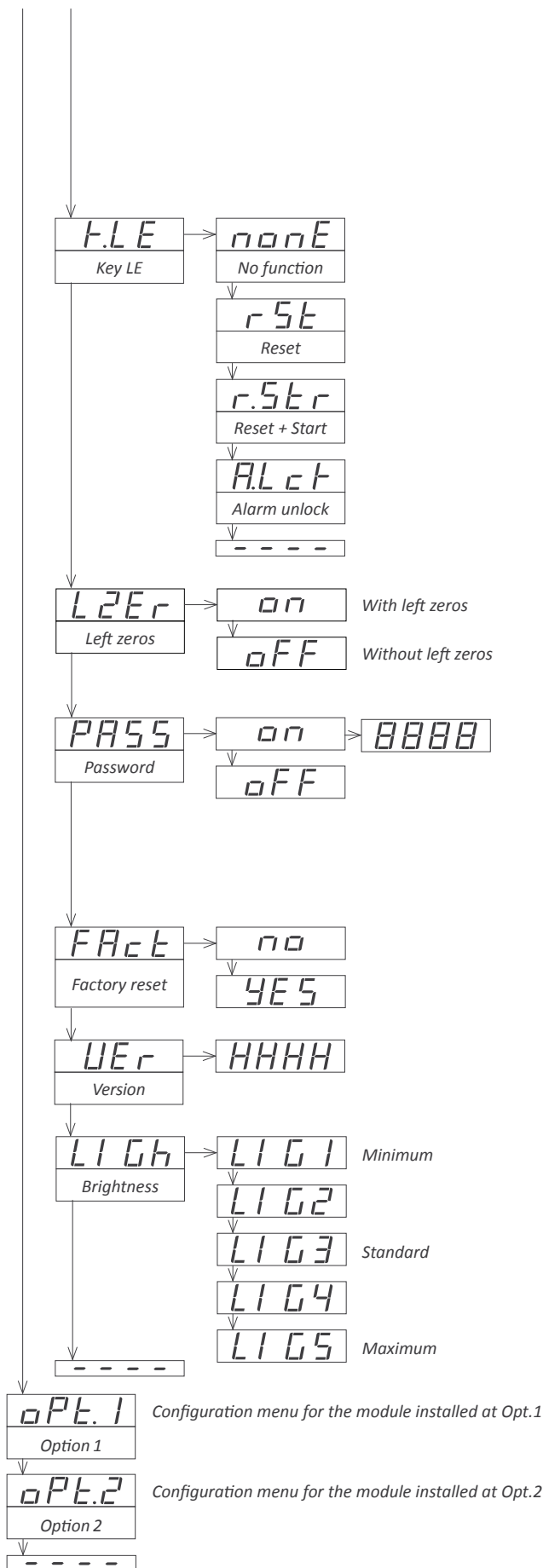

### 1.12.6 Super fast access

If only a single function is selected for the ‘fast access’ menu, pressing the the ‘UP’ (▲) key will shortly display the function name and then automatically jump to the function value.

### 1.12.7 Menu ‘Key LE’

The ‘LE’ (◀) key at the front of the instrument can be configured to activate several functions. Only one function can be assigned to the ‘LE’ (◀) key

- the ‘No function’ (‘nonE’) value assigns no function.
- the ‘Reset’ (‘rSt’) value assigns the reset function to the ‘LE’ (◀) key.
- the ‘Reset + Start’ (‘r.St’r’) value assigns the reset and start function to the ‘LE’ (◀) key.
- the ‘Alarm unlock’ (‘A.Lck’) value assigns the manual unlock of the alarms function, for instruments with the ‘Locked alarms’ (‘A.Lck’) function activated (see section 1.12.4)

### 1.12.8 Left zeros

The ‘Left zeros’ (‘L.ZEr’) parameter controls the left zeros on or off.

### 1.12.9 Function ‘Password’

At the ‘Password’ (‘PASS’) menu select a 4 digit code to block access to the ‘configuration menu’. Instrument configuration will not be accessible to non authorized personnel. To activate the ‘Password’ select ‘on’ and introduce the code.

The code will be requested when trying to access the ‘configuration menu’ (key ‘SQ’ (■)). The ‘fast access’ menu is not password protected.

### 1.12.10 Factory reset

At the ‘Factory reset’ (‘FAck’) menu, select ‘yes’ to load the default factory configuration for the instrument (see section 1.14).

### 1.12.11 Firmware version

The ‘Version’ (‘VEr’) menu informs of the current firmware version installed in the module.

### 1.12.12 Brightness

At the ‘Brightness’ (‘LIGH’) menu select the light intensity for the front leds. With this function it is possible to adapt the instrument to the environment light intensity.

### 1.12.13 Access to optional modules

Menus ‘Opt.1’ and ‘Opt.2’ give access to the ‘configuration menus’ of the output and control modules installed at slots Opt.1 and Opt.2.

See section 2 for a list of output and control modules available for each slot. The ‘configuration menu’ of each module is described at the User’s Manual of each module.

### 1.13 Full configuration menu

Press 'SQ' (■) for 1 second to access the 'Configuration menu'. See section 1.12 for a description of each menu entry.

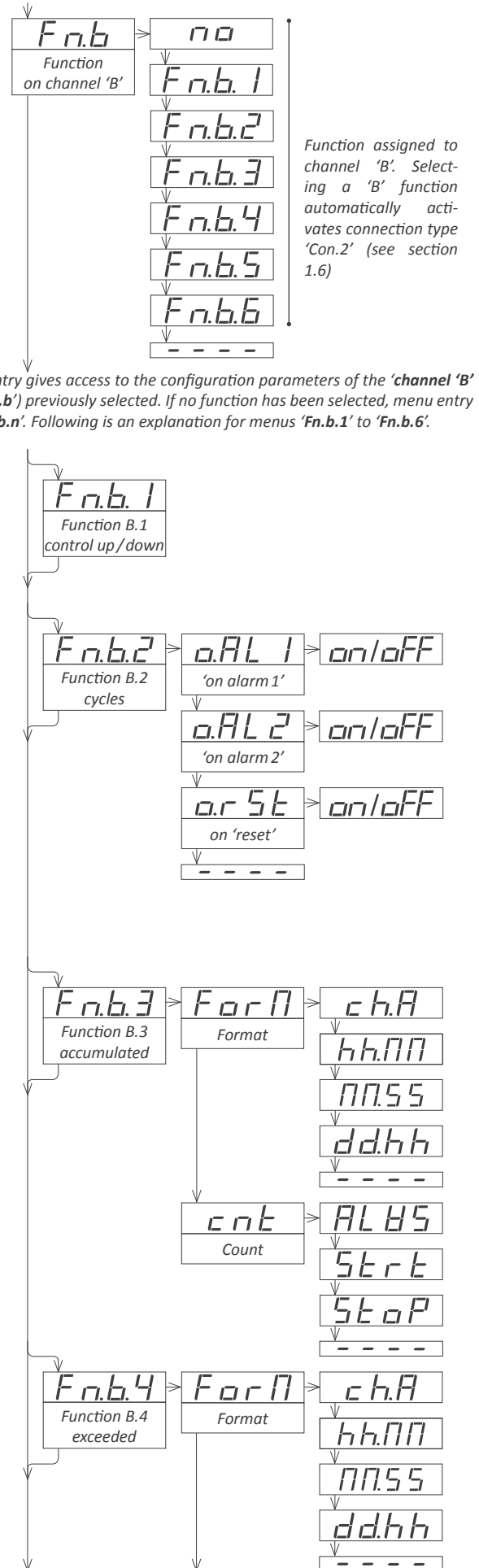
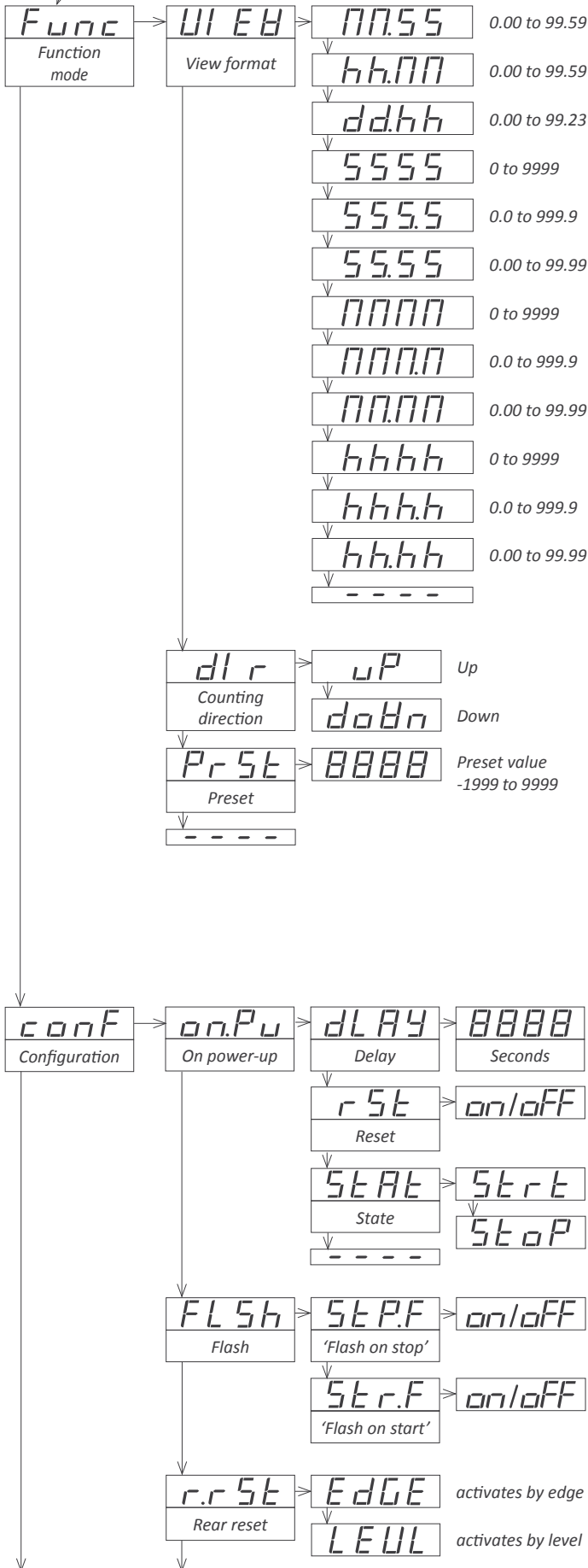

### 1.13 Full configuration menu (cont.)

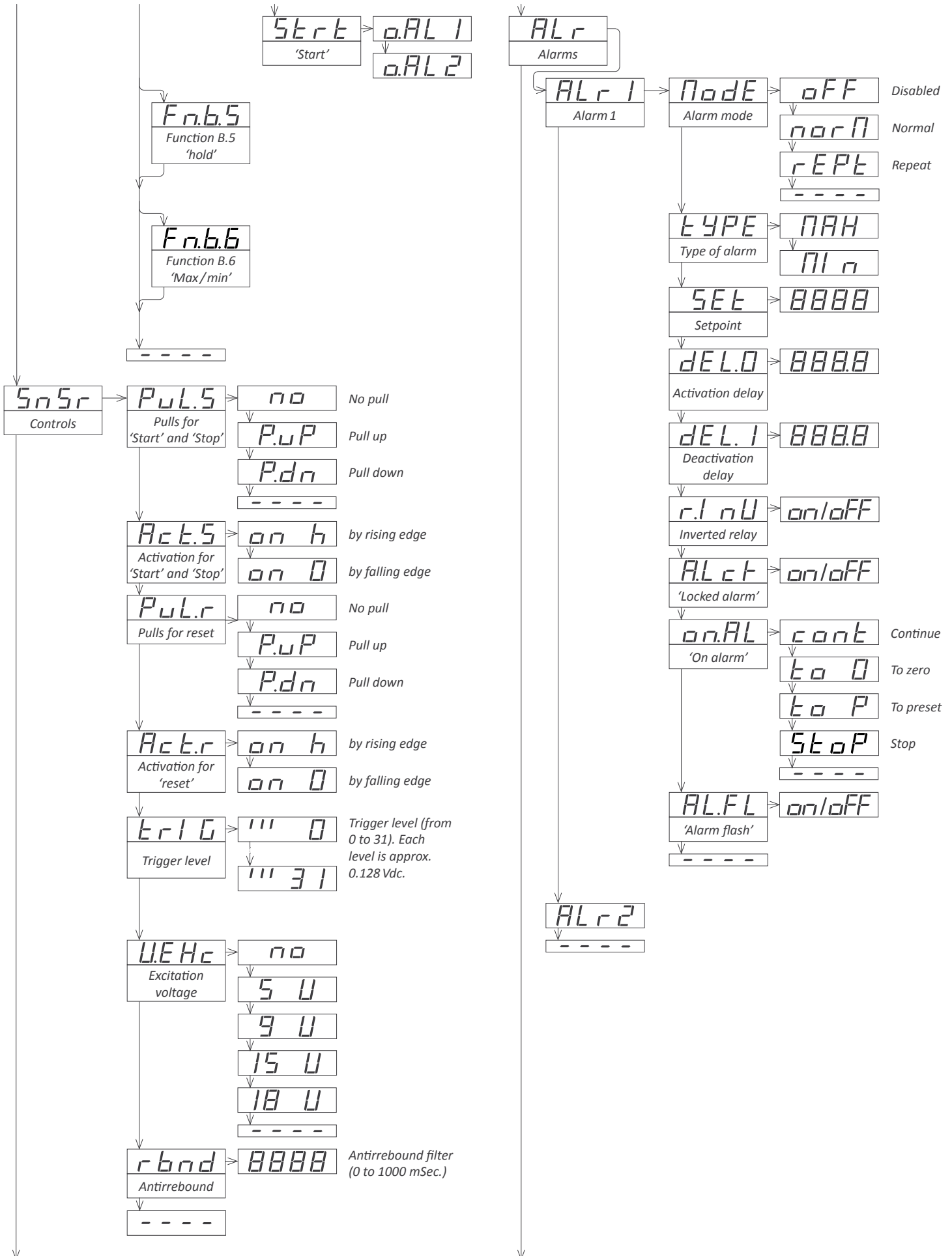

### 1.13 Full configuration menu (cont.)

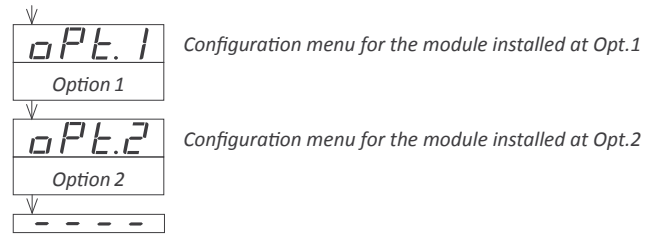
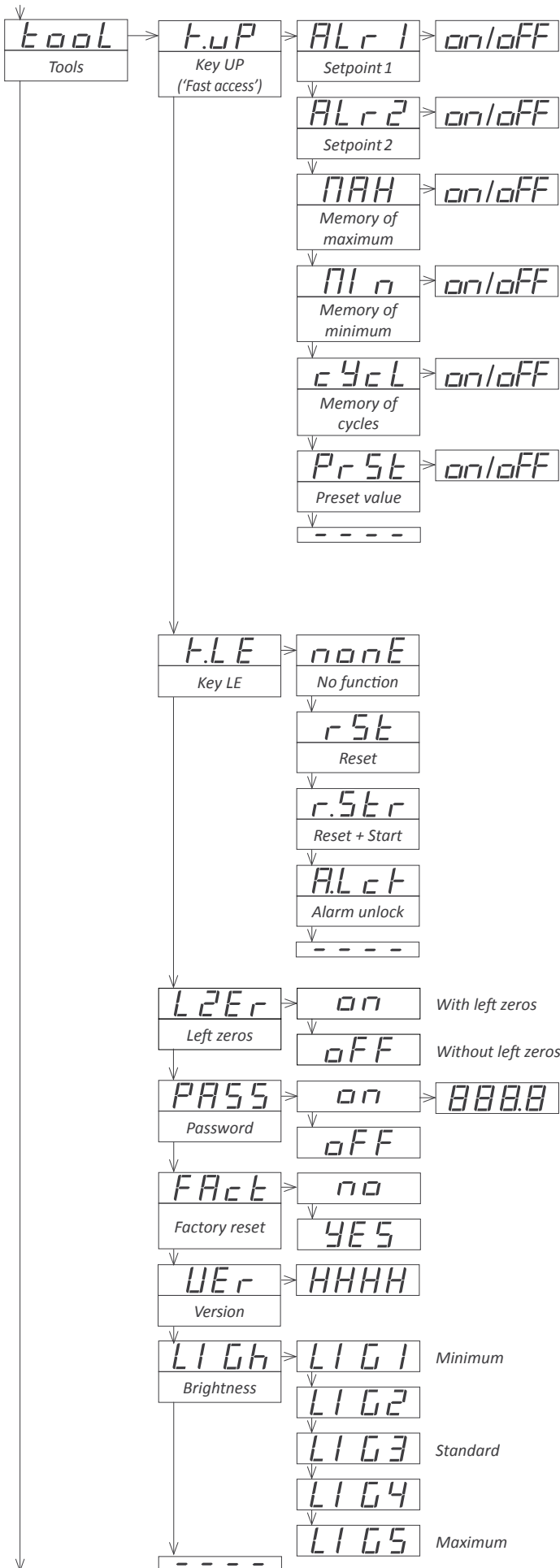

### 1.14 Factory configuration

Function mode	
View format	MM.SS
Counting direction	up
Preset	00.00
Configuration	
'On power-up'	
Delay	0 seconds
Reset	off
State	stopped ('StoP')
Flash	
'Flash on stop'	off
'Flash on start'	off
Rear reset	activates by edges ('EdGE')
Function on channel 'B'	no
Controls	
Pulls for 'start' and 'stop' pull-up ('P.uP')	
Activation for 'start' and 'stop' by falling edge ('on_0')	
Pulls for reset	pull-up ('P.uP')
Activation for reset	by falling edge ('on_0')
Trigger level	2.56 Vdc (level 20)
Excitation voltage	15 Vdc
Antirrebound filter	disabled (0 mSeconds)
Alarms 1 and 2	
Mode	off (disabled)
Type of alarm	of maximum
Setpoint	0
Activation delay	0.0 seconds
Deactivation delay	0.0 seconds
Inverted relay	off
'Locked alarms'	off
'On alarm'	continue
'Alarm flash'	off
Herramientas ('Tool')	
'Fast access' (key UP)	off
Setpoint 1	off
Setpoint 2	off
Memory of maximum	off
Memory of minimum	off
Cycles	off
Preset	off
Ley 'LE'	reset function
Left zeros	off
Password	off
Brightness	3



## 1.15 Application example 1

In an industrial process of electrolytic bath, the wetted parts need to be removed from the bath and replaced with new parts every 20 minutes. The process of removing and adding parts to the electrolytic bath is automated and takes 15 seconds. During these 15 seconds, the system of electrolytic bath should receive no power supply, which must be reactivated after 15 seconds, when new items are immersed in the bath.

The S40-CR chronometer can be configured to activate a relay output every 20 minutes, and this relay must remain active for 15 seconds. After this time, the relay will deactivate.

Additionally, the system needs the counter to start counting as soon as power is received, although a 60 seconds delay is needed to give time to the first activation of the electrolytic bath. Counter must continue counting from the value it had before the power was removed.

Configuration would be as indicated below :

- View format  
'Func' / 'View'                    'mm.ss'
- Counting direction  
'Func' / 'dir'                        up ('uP')
- Preset value  
'Func' / 'PrSt'                        '0.00'
- Delay on power-up  
'conF' / 'on\_Pu' / 'dLAY'        60 seconds
- Initial reset disabled  
'conF' / 'on\_Pu' / 'rSt'            'oFF'
- Start counting after power-up  
'conF' / 'on\_Pu' / 'StAt'          start ('Strt')
- Alarm mode  
'ALr' / 'ALr1' / 'Mode'            repeat ('rEPt')
- Alarm every 20 minutes  
'ALr' / 'ALr1' / 'SEt'                20.00
- Deactivation delay  
'ALr' / 'ALr1' / 'dEL.1'            15.0 seconds
- On alarm activation  
'ALr' / 'ALr1' / 'on\_AL'            continue ('cont')

## 1.16 Application example 2

An industrial process has an oven to dry different elements. The drying time of each element is variable, and the operator requires that the setting of each drying time to be easily accessible and modifiable. The modification of other configuration parameters must be locked. During the process, the operator needs two signals. First signal activates a buzzer which should start 5 minutes before the end of the scheduled drying time, and remain active for 15 seconds. The second signal must activate at the end of the drying time and must remain active until the operator manually the 'reset' signal.

The S40-CR chronometer can be configured for down counting, with start time at preset value, which will be directly accessible and modifiable when pressing the front key UP ('▲'). All configuration parameters (except the 'preset' value) will be password locked. Alarm 1 will activate for 15 seconds when 5 minutes are missing to end the process. Alarm 2 will activate when the scheduled time is over and will remain active until the operator manually resets.

- View format  
'Func' / 'View'                        'hh.mm'
- Counting direction  
'Func' / 'dir'                        down ('doWn')
- Alarm 1 : alarm mode  
'ALr' / 'ALr1' / 'Mode'            normal ('norM')
- Alarm 1 : type of alarm  
'ALr' / 'ALr1' / 'tYPE'            minimum ('MIn')
- Alarm 1 : activation setpoint  
'ALr' / 'ALr1' / 'SEt'                '00.05'
- Alarm 1 : deactivation delay  
'ALr' / 'ALr1' / 'dEL.1'            15.0 seconds
- Alarm 1 : continue counting when alarm activates  
'ALr' / 'ALr1' / 'on\_AL'            continue ('cont')
- Alarm 2 : alarm mode  
'ALr' / 'ALr1' / 'Mode'            normal ('norM')
- Alarm 2 : type of alarm  
'ALr' / 'ALr1' / 'tYPE'            minimum ('MIn')
- Alarm 2 : activation setpoint  
'ALr' / 'ALr1' / 'SEt'                '00.00'
- Alarm 1 : when alarm activates, stop counting  
'ALr' / 'ALr1' / 'on\_AL'            stop ('stop')
- Assign the preset value to the 'UP' front key  
'Tool' / 'K.uP' / 'PrSt'            'on'
- Configuration block by password  
'Tool' / 'PASS' / 'on'                assign the password code

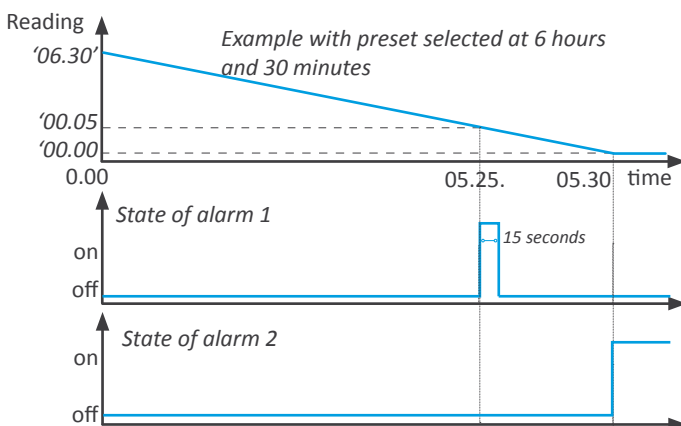
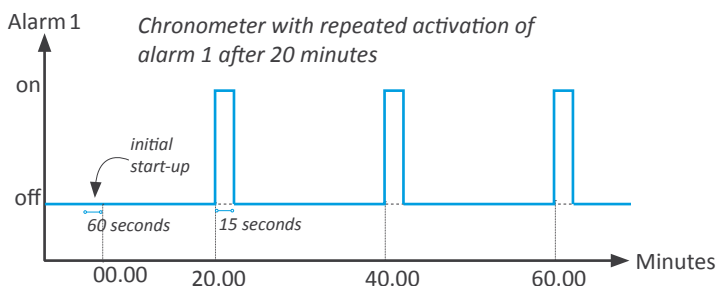

## 1.17 To access the instrument

You may need to access the inside of the instrument to add or replace internal modules. Use a flat screwdriver to unlock the upper clips marked with 'A'. Then unlock the lower clips marked with 'B' and remove the front cover. Let the inside of the instrument slide out of the housing.

To reinsert the instrument make sure that all modules are correctly connected to the pins on the display module. Place all the set into the housing, assuring that the modules correctly fit into the internal guiding slides of the housing. Once introduced, place again the front cover by clipping first the upper clips 'A' and then the lower clips 'B'.

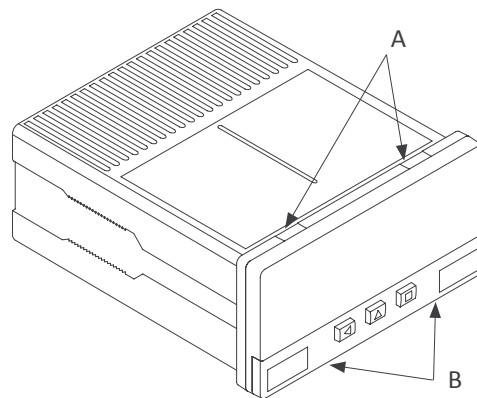

*Risk of electric shock. Removing the front cover will grant access to the internal circuits. Disconnect the input signal to prevent electric shock to the operator. Operation must be performed by qualified personnel only.*

## 1.18 Modular system

Series S panel meters are designed to create a modular system. This modular system allows for addition, replacement or substitution of any of the internal modules conforming the instrument. Below is a graphic explanation for the position of each module.

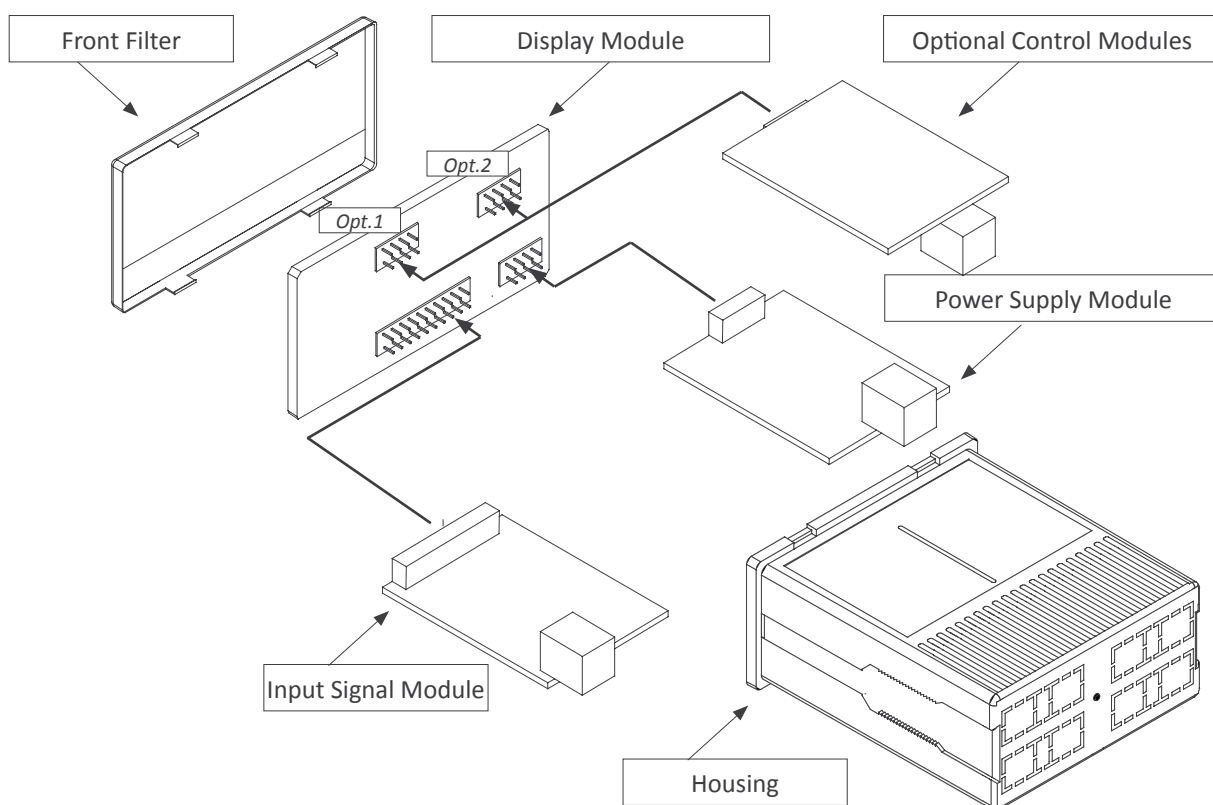

## 1.19 Precautions on installation



Risk of electrical shock. Instrument terminals can be connected to dangerous voltage.



Instrument protected with double isolation. No earth connection required.



Instrument conforms to CE rules and regulations.

This instrument has been designed and verified conforming to the 61010-1 CE Security Regulation, for industrial applications.

Installation of this instrument must be performed by qualified personnel only. This manual contains the appropriate information for the installation. Using the instrument in ways not specified by the manufacturer may lead to a reduction of the specified protection level. Disconnect the instrument from power before starting any maintenance and / or installation action.

The instrument does not have a general switch and will start operation as soon as power is connected. The instrument does not have protection fuse, the fuse must be added during installation.

The instrument is designed to be panel mounted. An appropriate ventilation of the instrument must be assured. Do not expose the instrument to excess of humidity. Maintain clean by using a humid rag and do NOT use abrasive products such as alcohols, solvents, etc.

General recommendations for electrical installations apply, and for proper functionality we recommend : if possible, install the instrument far from electrical noise or magnetic field generators such as power relays, electrical motors, speed variators, ... If possible, do not install along the same conduits power cables (power, motor controllers, electrovalves, ...) together with signal and/or control cables.

Before proceeding to the power connection, verify that the voltage level available matches the power levels indicated in the label on the instrument.

In case of fire, disconnect the instrument from the power line, fire alarm according to local rules, disconnect the air conditioning, attack fire with carbonic snow, never with water.

## 1.20 Warranty

This instrument is warranted against all manufacturing defects for a period of 24 MONTHS from the shipment date. This warranty does not apply in case of misuse, accident or manipulation by non-authorized personnel. In case of malfunction get in contact with your local provider to arrange for repair. Within the warranty period and after examination by the manufacturer, the unit will be repaired or substituted when found to be defective. The scope of this warranty is limited to the repair cost of the instrument, not being the manufacturer eligible for responsibility on additional damages or costs.

## 1.21 CE declaration of conformity

Manufacturer FEMA ELECTRÓNICA, S.A.  
Altimira 14 - Pol. Ind. Santiga  
E08210 - Barberà del Vallès  
BARCELONA - SPAIN  
www.fema.es - info@fema.es

Products S40-CR

The manufacturer declares that the instruments indicated comply with the directives and rules indicated below.

Electromagnetic compatibility directive 2004/108/CE  
Low voltage directive 2006/95/CE

### Security rules EN-61010-1

Instrument Fixed  
Permanently connected  
Pollution degree 1 and 2 (without condensation)  
Isolation Double

### Electromagnetic compatibility rules EN-61326-1

EM environment Industrial

### Immunity levels

EN-61000-4-2	By contact $\pm 4$ KV By air $\pm 8$ KV	Criteria B Criteria B
EN-61000-4-3		Criteria A
EN-61000-4-4	On AC power lines : $\pm 2$ KV On DC power lines : $\pm 2$ KV On signal lines : $\pm 1$ KV	Criteria B Criteria B Criteria B
EN-61000-4-5	Between AC power lines $\pm 1$ KV Between AC power lines and earth $\pm 2$ KV Between DC power lines $\pm 1$ KV Between DC power lines and earth $\pm 2$ KV Between signal lines and earth $\pm 1$ KV	Criteria B Criteria B Criteria B Criteria B Criteria B
EN-61000-4-6		Criteria A
EN-61000-4-8	30 A/m at 50/60 Hz	Criteria A
EN-61000-4-11	0% 1 cycle 40% 10 cycles 70% 25 cycles 0% 250 cycles	Criteria A Criteria A Criteria B Criteria B

### Emission levels

CISPR 11 Instrument Class A, Group 1 Criteria A

Barberà del Vallès October 2014  
Daniel Juncà - Quality Manager



According to directive 2012/19/EU, electronic equipment must be recycled in a selective and controlled way at the end of its useful life.

# 2. Output and control modules

## 2.1 Module R1

The R1 module provides 1 relay output to Series S panel meters. Up to a maximum of 2 R1 modules can be installed in a single instrument (2 relays).

*Note : for more than three relays per instrument or larger relay density per module, see special modules R2 and R4 at section 2.6.*

Relays with 3 contacts each (common, normally closed, normally open), with switching capability up to 250V @ 8A.

Modules R1 are configured from the 'ALr1' and 'ALr2' alarm menus of the panel meter. The 'ALrX' menus provide configuration for main setpoint, hysteresis, independent activation and deactivation delays, and a second setpoint to create windowed alarms.

Modules R1 are installed on slot 'Opt.1' or 'Opt.2' (see section 1.18) and are configured from instruments front keypad.

The R1 module can be ordered pre-installed into a Series S panel meter, or standalone for delayed installation, as they do not require soldering or special configuration.

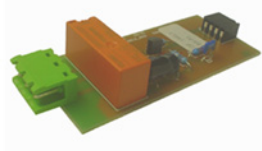

<b>Type of relay</b>	3 contact relay (NC, NO, common)
<b>Current maximum</b>	8A per relay (resistive load)
<b>Voltage maximum*</b>	250 Vac continuous
<b>Isolation</b>	3500 Veff
<b>Type of terminal</b>	plug-in screw terminal, pitch 5.08 mm
<b>Slots allowed</b>	'Opt.1', 'Opt.2' (see section 1.18)

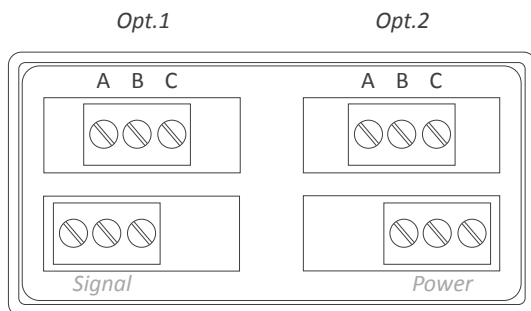

Terminal A	Common
Terminal B	NO - Normally Open
Terminal C	NC - Normally Closed

For more information see document 3535\_MODULE-S\_R1\_manual\_i.pdf

## 2.2 Module AO

The AO module provides 1 analog output with 4/20 mA or 0/10 Vdc configurable output range. Output current loop configurable as active (the instrument provides the excitation for the loop) or passive (the loop is externally powered). Signal output proportional to the instruments reading. Fully configurable scaling, in direct (positive slope) or inverse (negative slope) scaling.

Up to a maximum of 2 analog output modules can be installed in a single instrument, all outputs isolated between them and isolated from the power and input signal circuits.

Configuration from instrument front keypad, through menu entries 'Opt.1' or 'Opt.2', depending on the position the module is installed (see section 1.18).

The AO module can be ordered pre-installed into a Series S panel meter, or standalone for delayed installation, as it does not require soldering or special configuration.



<b>Output ranges</b>	4/20 mA active, 4/20 mA passive 0/10 Vdc
<b>Accuracy (at 25 °C)</b>	<0.1% FS
<b>Isolation</b>	1000 Vdc
<b>Slots allowed</b>	'Opt.1', 'Opt.2' (see section 1.18)

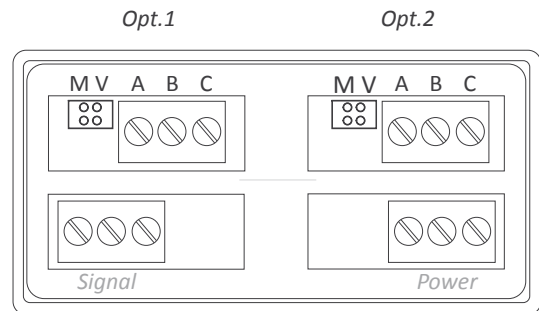

Terminal A	Vexc
Terminal B	Signal in mA or Vdc
Terminal C	GND
Jumper M	closed for mA
Jumper V	closed for Vdc

For more information see document 3525\_MODULE-S\_AO\_manual\_i.pdf

## 2.3 Module RTU

The RTU module provides a Modbus RTU communications module for Series S of panel meters. The RTU module implements function '4' ('Read Input Registers') of the Modbus RTU protocol, to access the instrument registers (reading value, alarm status, memory of maximum and minimum, ...)

Configuration from instrument front keypad, through menu entries 'Opt.1' or 'Opt.2', depending on the position the module is installed (see section 1.18).

The RTU module can be ordered pre-installed into a Series S panel meter, or standalone for delayed installation, as it does not require soldering or special configuration.



<b>Protocol</b>	Modbus RTU
<b>Functions implemented</b>	4 (Read_Input_Registers)
<b>Bus type</b>	RS-485, up to 57.6 Kbps
<b>Isolation</b>	1000Vdc
<b>Slots allowed</b>	'Opt.1', 'Opt.2' (see section 1.18)

Opt.1

Opt.2

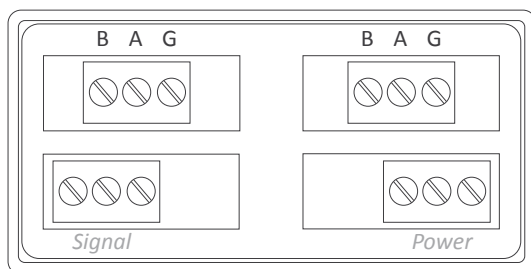

Terminal B      B signal from RS-485 bus  
 Terminal A      A signal from RS-485 bus  
 Terminal G      GND

## 2.4 Module S4

The S4 module provides a RS-485 communications module for Series S of panel meters. ASCII protocol with 'Master' / 'Slave' architecture. Addressable with up to 31 modules. Frames codified in representable ASCII characters (codes 32 to 255), directly visible using 'hyper-terminal' or similar programs.

- Configurable for direct retransmission to remote meter S40-S4 (14 mm digit height) and BDF Series (60 mm and 100 mm digit height).
- Access to display values, alarm status, memory of maximum and minimum, alarm setpoints, ...

Configuration from instrument front keypad, through menu entries 'Opt.1' or 'Opt.2', depending on the position the module is installed (see section 1.18).

The S4 module can be ordered pre-installed into a Series S panel meter, or standalone for delayed installation, as it does not require soldering or special configuration.



<b>Protocol</b>	ASCII
<b>Bus type</b>	RS-485, up to 57.6 Kbps
<b>Isolation</b>	1000Vdc
<b>Slots allowed</b>	'Opt.1', 'Opt.2' (see section 1.18)

Opt.1

Opt.2

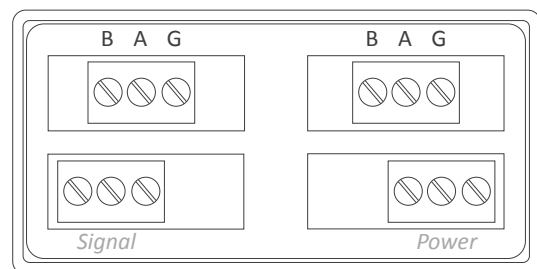

Terminal B      B signal from RS-485 bus  
 Terminal A      A signal from RS-485 bus  
 Terminal G      GND

For more information see document 3529\_MODULE-S\_RTU\_manual\_i.pdf

For more information see document 3530\_MODULE-S\_S4\_manual\_i.pdf

## 2.5 Module S2

The S2 module provides a RS-232 communications module for Series S of panel meters. ASCII protocol with 'Master' / 'Slave' architecture. Addressable with up to 31 modules. Frames codified in representable ASCII characters (codes 32 to 255), directly visible using 'hyper-terminal' or similar programs.

- Access to display values, alarm status, memory of maximum and minimum, alarm setpoints, ...

Configuration from instrument front keypad, through menu entries 'Opt.1' or 'Opt.2', depending on the position the module is installed (see section 1.13).

The S2 module can be ordered pre-installed into a Series S panel meter, or standalone for delayed installation, as it does not require soldering or special configuration.



<b>Protocol</b>	ASCII
<b>Bus type</b>	RS-232, up to 57.6 Kbps
<b>Isolation</b>	1000 Vdc
<b>Slots allowed</b>	'Opt.1', 'Opt.2' (see section 1.18)

## 2.6 Modules R2, R4

The R2 and R4 modules provide 2 and 4 relay outputs for Series S panel meters. Relays with 3 contacts each, with switching capability up to 250V @ 6A.

Modules R2 and R4 are installed on slot 'Opt.1' (see section 1.13) and are configured from instruments front keypad, and provide setpoint configuration, hysteresis, independent activation and deactivation delays, and second alarm setpoint for windowed alarms.

Only one module R2 or R4 can be installed per instrument. Modules R2 and R4 are not compatible with standard R1 modules.

The R2 and R4 modules can be ordered pre-installed into a Series S panel meter, or standalone for delayed installation, as they do not require soldering or special configuration.



<b>Type of relay</b>	3 contact relay (NC, NO, common)
<b>Current maximum</b>	6 A per relay (resistive load)
<b>Voltage maximum*</b>	250 Vac continuous
<b>Isolation</b>	2500 Veff
<b>Type of terminal</b>	plug-in screw terminal, pitch 3.81 mm
* terminals approved for 300 V (according to UL1059, groups B and D) and 160 V (according to VDE on CAT-III and pollution degree 3).	
Module R2	occupies Opt.1
Module R4	occupies Opt.1 and Opt.2

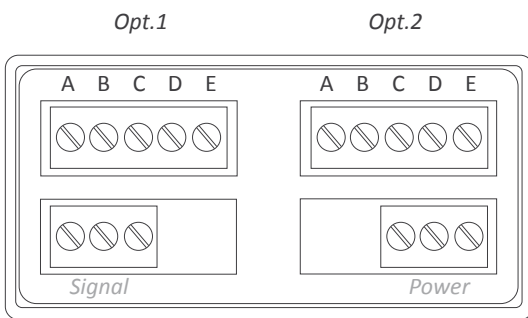

Terminal A	GND
Terminal B	Rx1
Terminal C	Tx1
Terminal D	Rx2
Terminal E	Tx2

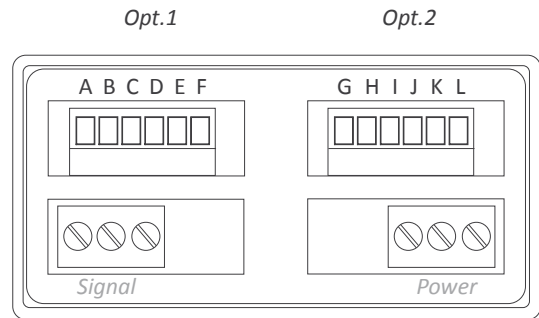

Relay	Common	Normally Open (NO)	Normally Closed (NC)
relay 1	A	B	C
relay 2	D	E	F
relay 3	G	H	I
relay 4	J	K	L

Table 3 - Connections for modules R2 and R4

For more information see document 3531\_MODULE-S\_S2\_manual\_i.pdf

For more information see document 3533\_MODULES-S\_R2-R4\_manual\_i.pdf

## 3. Accessories

### 3.1 Option G

Green led digits.



## 4. Other options

### 4.1 Adapter KA72

Adapter 72 x 72 mm for 72 x 36 mm instruments.





Panel meters  
Standard 96x48 mm



Panel meters  
Miniature 48x24 mm



Signal converters



Panel meters  
Compact 72x36 mm



Large format meters



Bar meters



Isolators



Low cost



'Customized'  
instruments

# FEMA

ELECTRÓNICA

FEMA ELECTRÓNICA, S.A.

Altimira 14 - Pol. Ind. Santiga  
E08210 Barberà del Vallès  
BARCELONA - SPAIN

■ Tel. +34 93.729.6004  
Fax +34 93.729.6003

■ [info@fema.es](mailto:info@fema.es)  
[www.fema.es](http://www.fema.es)

