

Service Manual

ViewSonic VA702-2

VA721-3

VA721b-3

Model No. VS10781

17" Color TFT LCD Display

(VA702-2_VA721-3_VA721b-3_SM Rev. 1b Sep. 2006)

ViewSonic 381 Brea Canyon Road, Walnut, California 91789 USA – (800) 888-8583

Copyright

Copyright © 2006 by ViewSonic Corporation. All rights reserved. No part of this publication may be reproduced, transmitted, transcribed, stored in a retrieval system, or translated into any language or computer language, in any form or by any means, electronic, mechanical, magnetic, optical, chemical, manual or otherwise, without the prior written permission of ViewSonic Corporation.

Disclaimer

ViewSonic makes no representations or warranties, either expressed or implied, with respect to the contents hereof and specifically disclaims any warranty of merchantability or fitness for any particular purpose. Further, ViewSonic reserves the right to revise this publication and to make changes from time to time in the contents hereof without obligation of ViewSonic to notify any person of such revision or changes.

Trademarks

Optiquest is a registered trademark of ViewSonic Corporation.

ViewSonic is a registered trademark of ViewSonic Corporation.

All other trademarks used within this document are the property of their respective owners.

Revision History

Revision	SM Editing Date	ECR Number	Description of Changes	Editor
1a	03/06/2006		Initial Release	Jamie Chang
1b	09/01/2006	VS-E060223 VS-E060293	Add panel source (MT170EN01 V7) Add panel source (MT170EN01 VA)	Jamie Chang

TABLE OF CONTENTS

1. Precautions and Safety Notices	1
2. Specification	4
3. Front Panel Function Control Description	13
4. Circuit Description	17
5. Adjustment Procedure	27
6. Troubleshooting Flow Chart	33
7. Recommended Spare Parts List	40
8. Exploded Diagram and Exploded Parts List	46
9. Block Diagram	50
10. Schematic Diagrams	51
11. PCB Layout Diagrams	59

1. Precautions and Safety Notices

SAFETY PRECAUTIONS

This monitor is manufactured and tested on a ground principle that a user's safety comes first. However, improper used or installation may cause damage to the monitor as well as to the user.

WARNINGS:

- This monitor should be operated only at the correct power sources indicated on the label on the rear of the monitor. If you're unsure of the power supply in you residence, consult your local dealer or Power Company.
- Use only the special power adapter that comes with this monitor for power input.
- Do not try to repair the monitor by yourself, as it contains no user-serviceable parts. Only the qualified technician can repair it.
- Do not remove the monitor cabinet. There are high-voltage parts inside that may cause electric shock to human bodies.
- Stop using the monitor if the cabinet is damaged. Have it checked by a service technician.
- Put your monitor only in a lean, cool, dry environment. If it gets wet, unplug the power cable immediately and consult your closed dealer.
- Always unplug the monitor before cleaning it. Clean the cabinet with a clean, dry cloth. Apply non-ammonia based cleaner onto the cloth, not directly onto the glass screen.
- Do not place heavy objects on the monitor or power cord.





PRODUCT SAFETY NOTICE

Many electrical and mechanical parts in this chassis have special safety visual inspections and the protection afforded by them cannot necessarily be obtained by using replacement components rated for higher voltage, wattage, etc. Before replacing any of these components read the parts list in this manual carefully. The use of substitute replacement parts, which do not have the same safety characteristics as specified in the parts list, may create shock, fire, or other hazards.

SERVICE NOTES

- When replacing parts or circuit boards, clamp the lead wires around terminals before soldering.
- Keep wires away from high voltage, high temperature components and sharp edges.
- Keep wires in their original position so as to reduce interference.
- Adjustment of this product please refers to the user' manual.

Handling and Placing Methods

Correct Methods:	Incorrect Methods:
<p data-bbox="135 219 813 324">Only touch the metal of the LCD panel or the front cover of the monitor. Do not touch the surface of the polarizer.</p> 	<p data-bbox="834 235 1513 302">Surface of the LCD panel is pressed by fingers and that may cause "Mura".</p> 
<p data-bbox="135 1019 606 1052">Take out the monitor with cushions.</p> 	<p data-bbox="834 1008 1513 1075">Taking out the monitor by grasping the LCD panel. That may cause "Mura".</p> 

Correct Methods:

Place the monitor on a clean and soft foam pad.



Incorrect Methods:

Placing the monitor on foreign objects, That could scratch the surface of the panel or cause "Mura".



The panel is placed facedown on the lap. That may cause "Mura".



2. Specification

1. INTRODUCTION

	FEATURES	VA702/b-2 / VA702/b-2U
1 st panel source TFTLCD PANEL	Size	17 "
	Luminance (Typ)	300 cd/m ²
	Contrast Ratio (Typ)	500:1
	Colors (6 bits + 2 bits FRC)	16.2 M
	Response Time (Typ)	8 ms
	Viewing Angle (H/V)	140 ° / 130 °
	Recommend resolution	1280x1024@60Hz
2 nd panel source TFTLCD PANEL	Size	17 "
	Luminance (Typ)	300 cd/m ²
	Contrast Ratio (Typ)	500:1
	Colors (6 bits + 2 bits FRC)	16.2 M
	Response Time (Typ)	8 ms
	Viewing Angle (H/V)	150 ° / 135 °
	Recommend resolution	1280x1024@60Hz
3 rd panel source TFTLCD PANEL	Size	17 "
	Luminance (Typ)	280 cd/m ²
	Contrast Ratio (Typ)	600:1
	Colors (6 bits + 2 bits FRC)	16.2 M
	Response Time (Typ)	8 ms
	Viewing Angle (H/V)	150 ° / 135°
Input Signal	Analog (75ohms, 0.7/1.0 Vp-p)	Yes
	Digital	No
Sync Compatibility	Separate Sync	Yes
	Composite Sync	No
	Sync on Green	No
Compatibility	PC	Yes
	Power Mac	Yes
	TV Box (NextVision 6)	Yes
Power Voltage	AC 100-240V, 50/60Hz	Yes
Power Consumption	On Mode(Max / Typ)	36 W/ 35 W
	Off Mode (Max)	≤ 1 W
Audio		No
Ergonomics	Tilt (20 ° - -5 °)	Yes
	Swivel	No
	Pivot	No
	Height Adjust	No
OSD Control	[1] [▼] [▲] [2] [☺]	Yes
Dimension	Physical (W x H x D)	378 x 374 x 196 mm
	Package (W x H x D)	440 x 511 x 132 mm
Weight	Physical (Net Weight)	4.5 kg
	Package (Gross Weight)	6.2 kg
Operating Condition	Temperature (°F/°C)	32°F-104°F / 0°C-40°C
	Humidity (%)	10 % - 90 %
Storage Condition	Temperature (°F/°C)	-4°F-140°F / -20°C-60°C
	Humidity (%)	5 % - 90 %
Regulation	UL, cUL, FCC-B, CB, CE, ENERGY, NOM, TUV/GS, TUV ERGO (covers ISO13406-2 & MPRII), TCO'03, GOST-R+20 ORIGINAL COPIES HYGIENIC, SASO, PCBC, VCCI, BSMI, CCC, (PSB), (C-TICK), TUV-S, Green Mark, Energy Star, WEEE, RoHS	

FEATURES		VA721/b-3
1 st panel source TFTLCD PANEL	Size	17 "
	Luminance (Typ)	300 cd/m ²
	Contrast Ratio (Typ)	500:1
	Colors (6 bits + 2 bits FRC)	16.2 M
	Response Time (Typ)	8 ms
	Viewing Angle (H/V)	150 ° / 135 °
	Recommend resolution	1280x1024@60Hz
2 nd panel source TFTLCD PANEL	Size	17 "
	Luminance (Typ)	280 cd/m ²
	Contrast Ratio (Typ)	600:1
	Colors (6 bits + 2 bits FRC)	16.2 M
	Response Time (Typ)	8 ms
	Viewing Angle (H/V)	150 ° / 135 °
	Recommend resolution	1280x1024@60Hz
Input Signal	Analog (75ohms, 0.7/1.0 Vp-p)	Yes
	Digital	No
Sync Compatibility	Separate Sync	Yes
	Composite Sync	No
	Sync on Green	No
Compatibility	PC	Yes
	Power Mac	Yes
	TV Box (NextVision 6)	Yes
Power Voltage	AC 100-240V, 50/60Hz	Yes
Power Consumption	On Mode(Max / Typ)	36 W/ 35 W
	Off Mode (Max)	≤ 1 W
Audio		No
Ergonomics	Tilt (20 ° - -5 °)	Yes
	Swivel	No
	Pivot	No
	Height Adjust	No
OSD Control	[1][▼][▲][2][⏏]	Yes
Dimension	Physical (W x H x D)	378 x 374 x 196 mm
	Package (W x H x D)	440 x 511 x 132 mm
Weight	Physical (Net Weight)	4.5 kg
	Package (Gross Weight)	6.2 kg
Operating Condition	Temperature (°F/°C)	32°F-104°F / 0°C-40°C
	Humidity (%)	10 % - 90 %
Storage Condition	Temperature (°F/°C)	-4°F-140°F / -20°C-60°C
	Humidity (%)	5 % - 90 %
Regulation	UL, cUL, FCC-B, CB, CE, ENERGY, NOM, TUV/GS, TUV ERGO (covers ISO13406-2 & MPRII), TCO'03 , GOST-R+20 ORIGINAL COPIES HYGIENIC, SASO, PCBC, VCCI, BSMI, CCC, (PSB), (C-TICK), TUV-S, Green Mark, Energy Star, WEEE, RoHS	

2 GENERAL specification

Test Resolution & Frequency	1280x1024 @ 60Hz
Test Image Size	Full Size
Contrast and Brightness Controls	Factory Default: Contrast = 70%, Brightness = 100%

3 VIDEO INTERFACE

Analog Input Connector	DB-15 (Analog), refer the appendix A
Video Cable Strain Relief	Equal to twice the weight of the monitor for five minutes
Video Cable Connector DB-15 Pin out	Compliant DDC 1/2B
Video Signals	Video RGB (Analog) - Separate
Video Impedance	75 Ohms (Analog)
Maximum PC Video Signal	950 mV with no damage to monitor
Maximum Mac Video Signal	1250 mV with no damage to monitor
Sync Signals	LVDS
DDC 1/2B	Compliant with Revision 1.3
Sync Compatibility	Separate Sync
Video Compatibility	Shall be compatible with all PC type computers, Macintosh computers, and after market video cards
Resolution Compatibility	640 x 350, 640 x 480, 720 x 400 (640 x 400*), 800 x 600, 832 x 624, 1024 x 768, 1152 x 870, 1280 x 720, 1280 x 1024
Exclusions	Not compatible with interlaced video

4 POWER SUPPLY

Internal Power Supply	Part Number: ILIPI-004
Input Voltage Range	90 TO 264 VAC
Input Frequency Range	47.5 TO 63 HERTZ
Short Circuit Protection	Output can be shorted without damage
Over Current Protection	2.4 A typical at 14.2 VDC
Leakage Current	3.5mA (Max) at 254VAC / 60Hz
Efficiency	80% typical at 115VAC Full Load
Fuse	Internal and not user replaceable
Power Dissipation	36w (max) / 35 Watts (typ)
Max Input AC Current	0.8 Arms @ 90VAC, 0.4 Arms @265VAC
INRUSH CURRENT (COLD START)	30 A @ 120VAC, 50 A (max) @ 220VAC
Power Supply Cold Start	Shall start and function properly when under full load, with all combinations of input voltage, input frequency, and operating temperature
Power Supply Transient Immunity	Shall be able to withstand an ANSI/IEEE C62.41-1980 2000V 200 ampere ring wave transient test with no damage
Power Supply Line Surge Immunity	Shall be able to withstand 1.5 times nominal line voltage for one cycle with no damage
Power Supply Missing Cycle Immunity	Shall be able to function properly, without reset or visible screen artifacts, when ½ cycle of AC power is randomly missing at nominal input
Power Supply Acoustics	The power supply shall not produce audible noise that would be detectable by the user. Audible shall be defined to be in compliance with ISO 7779 (DIN EN27779:1991) Noise measurements of machines acoustics. Power Switch noise shall not be considered

US Type Power Cable	Separate 3-prong NEMA 5-15P type plug. Length = 1.8m. Connects to display. Color = Black
European Type Power Cable	Schuko CEE7-7 type plug. Length = 1.8m, Connects to display. Color = Black
CCC Type Power Cable	Separate 3-prong type plug. Length = 1.8m. Connects to display. Color = Black
PSE Type Power Cable	Separate 2-prong NEMA 1-15P type plug. Length = 1.8m. Connects to display. Color = Black
Power Saving Operation(Method)	VESA DPMS Signaling
Power Consumption	On Mode < 36 W (max) Off Mode < 1W
Recovery Time	On Mode = N/A, Active Off < 3 sec

5 ELECTRICAL REQUIREMENT

Horizontal / Vertical Frequency

Horizontal Frequency	30 – 82 kHz
Vertical Refresh Rate	50 – 85* Hz. <small>* When the resolution is set to 1280 x 1024, the vertical refresh rate may be up to 75 Hz; for all other resolutions, the vertical refresh rate may be up to 85Hz.</small>
Maximum Pixel Clock	140 MHz
Sync Polarity	Independent of sync polarity.

Timing Table

Item	Timing	Analog
1	640 x 350 @ 70Hz, 31.5kHz	Yes
2	640 x 400 @ 60Hz, 31.5kHz	Yes
3	640 x 400 @ 70Hz, 31.5kHz	Yes
4	640 x 480 @ 50Hz, 24.7kHz	Yes
5	640 x 480 @ 60Hz, 31.5kHz	Yes
6	640 x 480 @ 67Hz, 35.0kHz	Yes
7	640 x 480 @ 72Hz, 37.9kHz	Yes
8	640 x 480 @ 75Hz, 37.5kHz	Yes
9	640 x 480 @ 85Hz, 43.27kHz	Yes
10	720 x 400 @ 70Hz, 31.5kHz	Yes
11	800 x 600 @ 56Hz, 35.1kHz	Yes
12	800 x 600 @ 60Hz, 37.9kHz	Yes
13	800 x 600 @ 75Hz, 46.9kHz	Yes
14	800 x 600 @ 72Hz, 48.1kHz	Yes
15	800 x 600 @ 85Hz, 53.7kHz	Yes
16	832 x 624 @ 75Hz, 49.7kHz	Yes
17	1024 x 768 @ 60Hz, 48.4kHz	Yes
18	1024 x 768 @ 70Hz, 56.5kHz	Yes
19	1024 x 768 @ 72Hz, 58.1kHz	Yes

20	1024 x 768 @ 75Hz, 60.0kHz	Yes
21	1024 x 768 @ 85Hz, 68.67kHz	Yes
22	1152 x 870 @ 75Hz, 68.7kHz	Yes
23	1280 x 1024 @ 60Hz, 63.4kHz	Yes
24	1280 x 1024 @ 75Hz, 79.97kHz	Yes
25	1280x 720 @ 60Hz, 45kHz (HDTV)	Yes

Primary Presets

1280x1024 @ 60Hz

User Presets

Number of User Presets (recognized timings) Available: 10 presets total in FIFO configuration

Changing Modes

Maximum Mode Change Blank Time for image stability: 3 seconds (Max), excluding "Auto Image Adjust" time.

Under DOS mode (640 x 350, 720 x 400 & 640 x 400), it should recall factory setting when execute "Auto Image Adjust".

The monitor needs to do "Auto Image Adjust" the first time when a new mode is detected. (See section "0-Touch™ Function Actions")

TFT LCD PANEL (for VA702-2)

Panel Characteristics:

1st Source Panel

Model number	Innolux MT170EN01 V2	
Type	TN type with LVDS interface	
Active Size	337.9 (H) x 270.3 (V)	
Pixel Arrangement	RGB Vertical Stripe	
Pixel Pitch	0.264 mm	
GLASS TREATMENT	Anti Glare (Hard coating 3H)	
# OF BACKLIGHTS	4 CCFL edge-light (2 top / 2 bottom)	
BACKLIGHT LIFE	40,000 Hours (Min) / 50,000 (Typ)	
Luminance (Center) – Condition: CT = 6500K, Contrast = Max, Brightness = Max	300 cd/m ² (Typ after 30 minute warm up) 250 cd/m ² (Min after 30 minute warm up)	
Brightness Uniformity (13 points)	0.8 (Typ), 0.75(Min) δ = Min Luminance of 13 points/Max Luminance of 13 points	
Contrast Ratio	500:1 (Typ), 400:1 (min)	
Color Depth	16.2 million colors (6 bits + 2 bits FRC)	
Viewing Angle (Horizontal)	@ CR>=10 Typical: 140° Minimum: 130°	@ CR>= 5 Typical: 160° Minimum: 140°
VIEWING ANGLE (VERTICAL)	@ CR>=10 Typical: 130° Minimum: 110°	@ CR>= 5 Typical: 160° Minimum: 140°
Response Time 10%-90% @ Ta=25°C	8 ms (Tr= 2 ms, Tf = 6 ms) (typ) 18 ms (Tr= 7 ms, Tf = 11 ms)(max)	
Panel Defects	Please see Panel Quality Specifications.	

2nd Source Panel

Model number	Innolux MT170EN01 V4	
Type	TN type with LVDS interface	
Active Size	337.9 (H) x 270.3 (V)	
Pixel Arrangement	RGB Vertical Stripe	
Pixel Pitch	0.264 mm	
GLASS TREATMENT	Anti Glare (Hard coating 3H)	
# OF BACKLIGHTS	4 CCFL edge-light (2 top / 2 bottom)	
BACKLIGHT LIFE	40,000 Hours (Min) / 50,000 (Typ)	
Luminance (Center) – Condition: CT = 6500K, Contrast = Max, Brightness = Max	300 cd/m ² (Typ after 30 minute warm up) 250 cd/m ² (Min after 30 minute warm up)	
Brightness Uniformity (13 points)	0.8 (Typ), 0.75(Min) δ = Min Luminance of 13 points/Max Luminance of 13 points	
Contrast Ratio	500:1 (Typ), 400:1 (min)	
Color Depth	16.2 million colors (6 bits + 2 bits FRC)	
Viewing Angle (Horizontal)	@ CR>=10 Typical: 150° Minimum: 130°	@ CR>= 5 Typical: 170° Minimum: 150°
VIEWING ANGLE (VERTICAL)	@ CR>=10 Typical: 135° Minimum: 115°	@ CR>= 5 Typical: 155° Minimum: 135°
Response Time 10%-90% @ Ta=25°C	8 ms (Tr= 2 ms, Tf = 6 ms) (typ) 18 ms (Tr= 7 ms, Tf = 11 ms)(max)	
Panel Defects	Please see Panel Quality Specifications.	

3rd Source Panel

Model number	Innolux MT170EN01 V7	
Type	TN type with LVDS interface	
Active Size	337.9 (H) x 270.3 (V)	
Pixel Arrangement	RGB Vertical Stripe	
Pixel Pitch	0.264 mm	
GLASS TREATMENT	Anti Glare (Hard coating 3H)	
# OF BACKLIGHTS	4 CCFL edge-light (2 top / 2 bottom)	
BACKLIGHT LIFE	40,000 Hours (Min) / 50,000 (Typ)	
Luminance (Center) – Condition: CT = 6500K, Contrast = Max, Brightness = Max	280 cd/m ² (Typ after 30 minute warm up) 250 cd/m ² (Min after 30 minute warm up)	
Brightness Uniformity (13 points)	0.8 (Typ), 0.75(Min) δ = Min Luminance of 13 points/Max Luminance of 13 points	
Contrast Ratio	600:1 (Typ), 500:1 (min)	
Color Depth	16.2 million colors (6 bits + 2 bits FRC)	
Viewing Angle (Horizontal)	@ CR>=10 Typical: 150° Minimum: 130°	@ CR>= 5 Typical: 170° Minimum: 150°
VIEWING ANGLE (VERTICAL)	@ CR>=10 Typical: 135° Minimum: 115°	@ CR>= 5 Typical: 155° Minimum: 135°
Response Time 10%-90% @ Ta=25°C	8 ms (typ) 16 ms (max)	
Panel Defects	Please see Panel Quality Specifications.	

TFT LCD PANEL (for VA721/b-3)

Panel Characteristics:

1st Source Panel

Model number	Innolux MT170EN01 V4	
Type	TN type with LVDS interface	
Active Size	337.9 (H) x 270.3 (V)	
Pixel Arrangement	RGB Vertical Stripe	
Pixel Pitch	0.264 mm	
GLASS TREATMENT	Anti Glare (Hard coating 3H)	
# OF BACKLIGHTS	4 CCFL edge-light (2 top / 2 bottom)	
BACKLIGHT LIFE	40,000 Hours (Min) / 50,000 (Typ)	
Luminance (Center) – Condition: CT = 6500K, Contrast = Max, Brightness = Max	300 cd/m ² (Typ after 30 minute warm up) 250 cd/m ² (Min after 30 minute warm up)	
Brightness Uniformity (13 points)	0.8 (Typ), 0.75(Min) δ = Min Luminance of 13 points/Max Luminance of 13 points	
Contrast Ratio	500:1 (Typ), 400:1 (min)	
Color Depth	16.2 million colors (6 bits + 2 bits FRC)	
Viewing Angle (Horizontal)	@ CR>=10 Typical: 150° Minimum: 130°	@ CR>= 5 Typical: 170° Minimum: 150°
VIEWING ANGLE (VERTICAL)	@ CR>=10 Typical: 135° Minimum: 115°	@ CR>= 5 Typical: 155° Minimum: 135°
Response Time 10%-90% @ Ta=25°C	8 ms (Tr= 2 ms, Tf = 6 ms) (typ) 18 ms (Tr= 7 ms, Tf = 11 ms)(max)	
Panel Defects	Please see Panel Quality Specifications.	

2nd Source Panel

Model number	Innolux MT170EN01 V7	
Type	TN type with LVDS interface	
Active Size	337.9 (H) x 270.3 (V)	
Pixel Arrangement	RGB Vertical Stripe	
Pixel Pitch	0.264 mm	
GLASS TREATMENT	Anti Glare (Hard coating 3H)	
# OF BACKLIGHTS	4 CCFL edge-light (2 top / 2 bottom)	
BACKLIGHT LIFE	40,000 Hours (Min) / 50,000 (Typ)	
Luminance (Center) – Condition: CT = 6500K, Contrast = Max, Brightness = Max	280 cd/m2 (Typ after 30 minute warm up) 250 cd/m2 (Min after 30 minute warm up)	
Brightness Uniformity (13 points)	0.8 (Typ), 0.75(Min) δ = Min Luminance of 13 points/Max Luminance of 13 points	
Contrast Ratio	600:1 (Typ), 500:1 (min)	
Color Depth	16.2 million colors (6 bits + 2 bits FRC)	
Viewing Angle (Horizontal)	@ CR>=10 Typical: 150° Minimum: 130°	@ CR>= 5 Typical: 170° Minimum: 150°
VIEWING ANGLE (VERTICAL)	@ CR>=10 Typical: 135° Minimum: 115°	@ CR>= 5 Typical: 155° Minimum: 135°
Response Time 10%-90% @ Ta=25°C	8 ms (typ) 16 ms (max)	
Panel Defects	Please see Panel Quality Specifications.	

Dimension (Desktop)

Width	378mm (14.9 inch)
Height	374 mm (14.7 inch)
Depth	196 mm (7.7 inch)
Monitor Weight	4.5 Kg (9.9 lbs)

*Refer to Figure 1

Dimension (Head Only / Wall Mount) – Unfolding the Monitor Stand

Width	378 mm (14.9 inch)
Height	424 mm (16.7 inch)
Depth	61 mm (2.38 inch)
Monitor Weight	4.5 Kg (9.9 lbs)

*Refer to Figure 1

Ergonomics

Tilt Up	From 0° up to $\geq 20^\circ$
Tilt Down	From 0° down to $-3^\circ \sim -5^\circ$

Cabinet Material

Display Head Plastic Material	ABS UL94-HB
Neck/Base Plastic Material	ABS UL94-HB
Internal Plastic Cabinet Components	All internal plastic cabinet components shall be in compliance with the requirements of TCO'03
Front Bezel Color	The reference for the bezel is the silver color (VA702) and the midnight gray color (VA702b) chip provided by ViewSonic
Neck, Base, and Rear Cover Color	The reference for the bezel is the black color (VA702) and the midnight gray color (VA702b) chip provided by ViewSonic. The color difference between any two cabinet components shall be less than 0.80 "Delta E", in the 1976 CIE L*a*b Color space.
Rear logo color	The rear logo is silver color with the black color background (VA702) and midnight gray color and background (VA702b) chip provided by ViewSonic
Cabinet Color Drift Due To UV-Light	The color drift due to UV-Light shall be less than 3.0 "Delta E" in the 1976 CIE L*a*b color space. Testing shall be performed according to the requirements of ASTM Test Method D4459-93.
Cabinet Texture	Mold-Tech # 11010 used on all external textured surfaces.
Samples	The supplier shall submit textured color chips, plastic material specifications, and Material Safety Data Sheets for approval.

3. Front Panel Function Control Description

1. Key Function Description

CONTROL KEY	KEYS FUNCTION
[AUTO] [2]	By pressing [AUTO] key, "Auto Image Adjust" is performed
[MENU] [1]	By pressing [MENU] key, Main menu display
[] []	A. When "MENU OSD" display, press these keys to change the contents of an adjustment item, or change an adjustment value B. When "MENU OSD" is un-display, press these keys to change brightness and contrast
[POWER]	Power on or power off the monitor

2. Hot Key Operation

CONTROL KEY	KEYS FUNCTION
[]+[]	Recall Contrast or Brightness while in the Contrast or Brightness adjustment, or recall both of Contrast and Brightness when the OSD is not open.
[1] + [2]	Toggle 720x400 and 640x400 mode when input 720x400 or 640x400 mode.
[1] + []+[]	White Balance (Not shown on user's guide)
[1] + []	Power Lock
[1] + []	OSD Lock
Remark : All the short cuts function are only available while OSD off	

3. OSD Control

3.1 OSD table

Layer 1	Layer 2	Layer 3
Auto Image Adjust		
Contrast/Brightness	Contrast (+ / -)	
	Brightness (+ / -)	
Color Adjust	Srgb	
	9300K	
	6500K	
	5400K	
	User Color	Red (+ / -)
		Green (+ / -)
		Blue (+ / -)
Information		
Manual Image Adjust	H/V Position	H Position (+ / -)
		V Position (+ / -)

	H Size	+ / -
	Fine Tune	+ / -
	Sharpness	+ / -
Setup Menu	Language Select	English
		French
		German
		Italian
		Spanish
		Finnish
		Japanese
		Simplified Chinese
	Traditional Chinese	
	Resolution Notice	On/Off
OSD Position	H Position (+ / -)	
	V Position (+ / -)	
OSD Time Out		
OSD Background	On/Off	
Memory Recall		

3.2 OSD lock Menu function

OSD Lock Menu Function Check		
Item	Method	Phenomenon
Activate OSD lock	[1] + [] 10S	Press any of buttons "1", " ", " ", "2" will appear "OSD Locked" 3s
Deactivate OSD lock:	[1] + [] 10S(again)	
<p>NOTICE:</p> <p>When the OSD is locked will lock all functions.</p> <p>Status bar indicating OSD Lock or Unlock is in progress and when complete it will indicate "OSD Locked"</p> <p>OSD Lock should not lock Power Button and Power Lock function</p>		

3.3 Power lock Menu function

Power Lock Menu Function Check		
Item	Method	Phenomenon
Activate Power Lock	[1] + [] 10S	Can not turn off the LCD; Press the power button will appear "Power Button Locked" OSD 3s; LCD would automatically turn back "On" when power is restored after a power failure
Deactivate Power Lock	[1] + [] 10S(again)	
<p>NOTICE: Status bar indicating Power Button lock or unlock is in progress and when complete it will indicate "Power Button Locked" Power should only be lockable in the "On State"</p>		

3.4 Resolution notice function

Resolution Notice Menu		
Item	Method	Phenomenon
Activate Resolution Notice Menu	Resolution Notice OSD should show on screen after changing to non-native mode for 30 sec, And it should disappear after 10s or by pushing button [1] or [2]	-----
Deactivate Resolution Notice Menu	Push button [2] under Resolution Notice OSD, select Disable	-----

3.5 Factory Mode Introduction

When input the signal, press "power key" to turn off the monitor. Press" []+[]+[⏻]" at the same time so as to enter factory mode. After power on, press "Menu[1]" key, you can see the Factory menu.

INL : Currently using panel model name

V2 050526 : Currently using firmware version information.

Auto Color : Automatically calibrate chip ADC parameter by using chip internal DAC

Color Temperature : The R, G, B of 9300K and 6500K and 5400K and User Mode

Colors are all generated from scaling back end.

4. Circuit Description

4.1 Switching Mode Power Supply

4.1.1 AC Current Input Circuit

P801 is a connector for connecting AC Power. F801 is a fuse to protect all the circuit. AC input voltage is from 90V to 264V. R820 and R821 joined between two inputting main circuit to prevent man from shock. L801 is used to clear up low frequency wave. C801 and C806 are used to discharge the waves that L801 produced. High frequency waves are damped by C801 and C806. D801 is a rectifier which composed of 4 build-in diodes, it inverts AC to DC.

4.1.2 High Voltage to Low Voltage Control Circuit

C805 is used to smooth the wave from rectifier. IC802 is a highly integrated PWM controller, which build-in a power MOSFET. When rectified DC high voltage is applied to the DRAIN pin during start-up, the MOSFET is off initially, and the CONTROL pin capacitor is charged through a switched high voltage current source connected internally between the DRAIN and CONTROL pins. When the CONTROL pin voltage V_c reaches approximately 5.8V, the control circuitry is activated and the soft-start begins. The soft-start circuit gradually increases the duty cycle of the MOSFET from zero to the maximum value over approximately 10ms. If no external feedback/supply current is fed into the CONTROL pin by the end of the soft-start, the high voltage current source is turned off and the CONTROL pin will start discharging in response to the supply current drawn by the control circuitry.

Resistor R803, R807, R824 and R825 are for line over voltage shut-down (OVP) and line under-voltage detection (UVP). Resistors R801, R805, R822, and R823 are for external current limit adjustment, and used to reduce the current limit externally to a value close to the operating peak current of primary about 1.35A. The mean is power will protected when the primary current over about 1.35A.

When PWM is turned off, the main current flow will be consumed through D804 and ZD802, This will prevent MOSFET which built-in IC802 from being damaged under large current impulse and voltage spike.

D806 and C815 provide internal Auxiliary current to CONTROL pin during normal operation. In addition, error amplifier and feedback current to the CONTROL pin are for duty cycle control.

4.1.3 DC_5V and DC_14V Output Circuit

For DC 5V, D805 is used to rectify the inducted current. R806 and C811 are used to store energy when current is reversed. The parts including C812, C814, C822, C821, B801 and L803 are used to smooth the current waves.

For DC 14V, D803 is used to rectify the inducted current. R802 and C802 are used to store energy when current is reversed. The parts including C808, C810 and L802 are used to smooth the current waves.

4.1.4 Feedback and OVP Protect Circuit

Pin R of IC803 is supplied 2.5V stable voltage. It is connected to 5V and 14V output through R811, R810 and R818. R811, R810 and R818 are output sampling resistor. When the sampling voltage more than 2.5V or less than 2.5V, feedback current of IC802 will change, this can change the voltage from transformer T801.

For 5V_{DC} output OVP, ZD803 is a zener diode, when 5V output voltage becomes up to 5.6V, the

zener current cause R819 voltage become up to 0.7V, Q801 is triggered and OVP starts. For 12V_{DC} output OVP, ZD804 is a Zener Diode, when 14V output voltage becomes up to 16V, the zener current cause R819 voltage become up to 0.7V, Q801 is triggered and OVP starts. The collector current of Q801 is used to make build-in diode light. FB Current of IC802 will be changed; it can change the voltage from T801.

Q802, R827, R828 and ZD801 make up of dummy loading circuit. For start-up sequence, during 5V output take place high loading first, this dummy loading circuit operated to insure 14V not be increased.

4.2 Inverter circuit

4.2.1 Low voltage to high voltage circuit

12V_{DC} supplies the power to IC501 through F501; the control signals that BRIGHTNESS and ON/OFF come from I/F board. ON/OFF signal connect to pin8 of IC501 and makes IC501 enabled. BRIGHTNESS is connected to pin7 of IC501 to adjust the panel luminance. R524, R529, C505 make up of a delay-time circuit and R528, R523, R524 make up of a voltage divided circuit. C504 is used to filter the high frequency noise. The operation frequency is determined by R522 and C529. For BURST MODE, its dimming frequency is determined by R527 and C506. C502 is used for soft start and compensation, C502, C528 are used to filter noise.

The output drives, including NDR4, NDRV2, PDRV3, PDRV1 (pins1, 3, 15, 16 respectively), generate a square pulses to drive MOSFET U501, U502. And U501, U502 works as full-bridge topology, it is high efficient, zero voltage switch.

During start up, VSEN (pin9) detects the voltage at the transformer secondary. When VSEN reaches 3.0V, the output voltage is regulated. If no current is detected for around 1.5 seconds, IC501 will shut down.

The current flowing through CCFL is detected and regulated through sense resistor R509, R511. The feedback voltage through R506, R507, and C508 connected to Pin11 (ISEN), and then compared with a reference voltage (1.5V) via a current amplifier, resulting in PWM drive outputs to full-bridge switches.

4.2.2 Protection circuit

Over Voltage Protection: R501 and R502 are connected in high voltage output connector, the divided AC voltage is inverted DC voltage through D508, R505 and C507 are used to rectify wave & dump noise. Then the voltage signal reaches Pin9 VSEN of IC501, when the voltage changes, build-in PWM of IC501 will adjust output voltage.

Open Lamp Protection: In normal operation, the resistors R510, R511, R512, R509 are sensed a high level AC voltage, the AC signal IS1 invert DC voltage through D509, R515, C533, and the high level DC voltage reaches the gate pin of Q502, similarly, the gate pin of Q503, Q504, Q505 has high level DC voltage. So the gate pin of Q501 has a low level voltage, and the IC501 is normal operation. Once one of signal IS1, IS2, IS3, and IS4 is low, the voltages of Q501 gate pin is high level, and make the voltage of ISEN low level, the IC501 will shut down.

4.3 I/F Board Circuit

4.3.1 Power Input

+5V is from the power board and supply for U101(FS8860-18PJ)、 U102(FS8860-33PJ)、 U105(MCU:W78E65P) and panel. +3.3V output is generated from +5V through C169 and C102 filtering, and U102 outputs. +3.3V is used for U104 (Scaler: TSU16AK). +1.8V output is generated from +5V through C169, C105 and C102 filtering, and U101 outputs. +1.8V is also used for U104.

4.3.2MCU (W78E65P)

VDD is +5V and its frequency of XTAL1 is 22.1184MHz. U105 #2 is defined as panel-enable. When the I/O port is low, Q101 and Q102 are conducted. And then after C109 and C110 filtering, obtain the voltage of VLCD, which will be connected to CN103. U105 #3 is defined as CCFL-enable. When the I/O port is low, Q103 is pulled up and the backlights are on; When the I/O port is high, Q103 is conducted and the backlights are off. U105 #4 is defined as DET-VGA, connected with CN102 #5. U105 #14, #36, #37, #38, #39, #40, #41, #42, #43 are the communications with U104 (Scaler), which are connected to #72, #31, #78, #77, #30, #70, #71, #69, #32 of Scaler. U105 #43 outputs reset signal to U104 (Scaler).

U106 is EEPROM used for saving EDID data, which is connected by SCL and SDA pins with #16 and #17 of MCU. Connect #12 to #26 of U105 for ISP.

4.3.3Scaler (TSU16AK)

The frequency of XTAL2 is 14.318MHz. U104 #1, #102-#103, #106-#113, #118-#125, #128 output LVDS digital data of 8 bit to panel control circuit through CN103. U104 #73 generates a PWM waveform by regulating the duty to control the brightness of the backlights. U104 #30-#32, #69-#72, #77-#78 are the communications with U105 (MCU) that are connected to #36-#43 of MCU. These communications include HWRESET, CSZ/ALE, SCL/RDZ, SDA/WRZ, and AD0-AD3.

4.3.4VGA Input

Signal R, G, B, SOG input through CN102 #1, #2, #3, and C115, C116, C117 and C118 filtering the high frequency noise. Signal HSYNC and VSYNC input through CN102 #13 and #14, and C119, R119, C120, R120 filtering. Then the analog signal enters U104, and then U104 deals with it internally. In addition, TVS101, TVS102, TVS103 (the three are BAV99), TVS104, TVS105, TVS106, TVS107 (they are constant voltage diode of 5V6) are ESD protector. Signal DDC-SCL inputs via CN102 #15, and then passes through TVS107 for ESD protection, goes into EDID EEPROM IC U103. Signal DDC-SDA inputs via CN102 #12, and then passes through TVS106 for ESD protection, goes into EDID EEPROM IC U103. CN102 #5 is defined as cable detect pin, this detector realizes via R107 and U105 #4. The PC-5V of U103 is supplied by PC via CN103 #9 with D103 for ESD protection, or supplied by Monitor self via D104. U103 is an EEPROM IC, which is a kind of memory and used for saving EDID data.

4.3.5Button Control

Button “Key-Power” is defined as power on/off, which is connected to U105 #24 through CN106 #4.

Button “Key-2” is defined as two functions of selecting and adjustment, which is connected to U105 #25 through CN106 #1.

Button “Key-Up” is defined as plus, which is connected to U105 #26 through CN106 #3.

Button “Key-Down” is defined as minus, which is connected to U105 #27 through CN106 #5.

Button “Key-1” is defined as two functions of menu and exit, which is connected to U105 #28

through CN106 #2.

LED indicator on the front bezel is defined as follows:

- a. When press button “Key-Power”, U105 #6 is pulled down and U105 #7 is pulled high, so Q104 is conducted and the LED indicator is green.
- b. When in power-saving mode, U105 #6 is pulled high and U105 #7 is pulled down, so Q105 is conducted and the LED indicator is orange.

FACTORY PRESET TIMING TABLE

Item	Resolution	H-Freq. (KHz)	V-Freq. (Hz)	Dot Clock (MHz)
1	640 x 350	31.5kHz	70Hz	25.2
2	640 x 400	31.5kHz	60Hz	25.2
3	640 x 400	31.5kHz	70Hz	25.2
4	640 x 480	24.7kHz	50Hz	19.8
5		31.5kHz	60Hz	25.2
6		35.0kHz	67Hz	30.2
7		37.9kHz	72Hz,	31.5
8		37.5kHz	75Hz,	31.5
9		43.27kHz	85Hz	36.0
10	720 x 400	31.5kHz	70Hz	28.3
11	800 x 600	35.1kHz	56Hz	36.0
12		37.9kHz	60Hz	40.0
13		48.1kHz	72Hz	50.0
14		46.9kHz	75Hz	49.5
15		53.7kHz	85Hz	56.3
16	832 x 624	49.7kHz	75Hz	57.3
17	1024 x 768	48.4kHz	60Hz	65.0
18		56.5kHz	70Hz	75.0
19		58.1kHz	72Hz	78.5
20		60.0kHz	75Hz	78.8
21		68.67kHz	85Hz	94.5
22	1152 x 870	68.6kHz	75Hz	100
23	1280 x 1024	63.4kHz	60Hz	108
24		79.97kHz	75Hz	135
25	1280 x 720	45kHz	60Hz	74.2

Power On/Off Sequence

1. Hardware Power ON

When power cord is plugged into AC socket, SMPS starts work and provides U105 and U106 with VCC5V. When VCPU inputs to U105, U105 resets circuit active, sets U105 all registers to preset modes, and then U105 #43 sends out a HWRESET signal voltage to reset U104, and then monitor goes into stand-by mode. That means hardware power on has been completed.

2. Software Power ON/OFF

When press power key, U105 #24 receives low pulse, and sends out "Power on/off" order back to U104, and then U104 will do the power on/off.

- If Power ON, U105 #6 (LED_Green) will send out High potential, and then LED green on.
- If Power OFF, U105 #7 (LED_Orange) will send out High potential, and then LED Orange on.

The Panel_Vcc, Backlight_En, CLK/DATA output to panel will follow the following sequence.

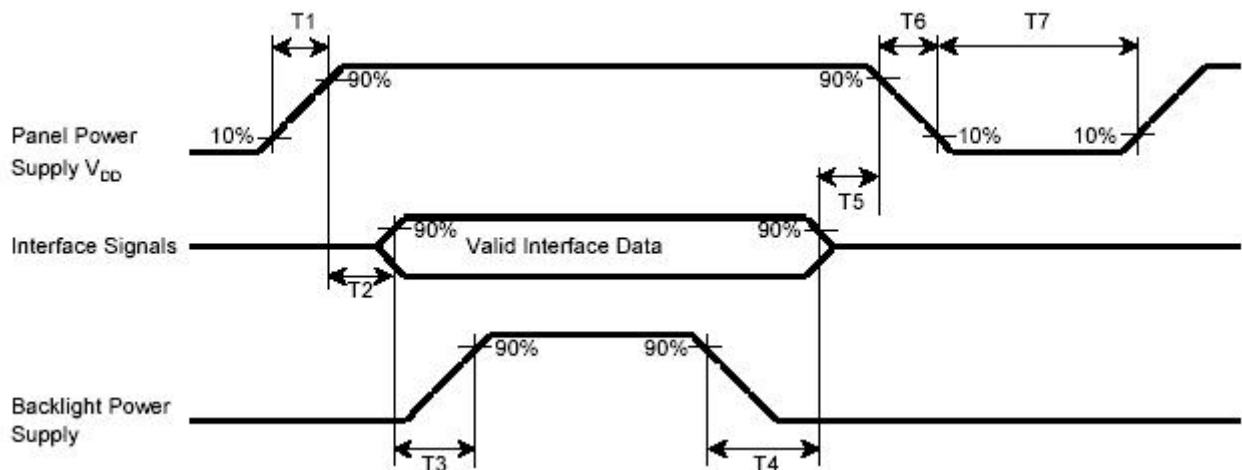

T1 (ms)	T2 (ms)	T3 (ms)	T4 (ms)	T5 (ms)	T6 (ms)	T7 (ms)
0.1~10	0~10	>200	>100	0~50	0.1~10	>1000

AC Outlet Pin Assignment

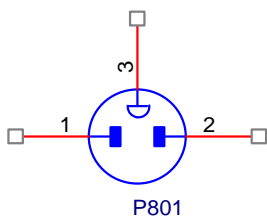

Pin	Symbol	Description
1	L	Live
2	N	Neutral
3	E	GND

Inner Connector Pin Assignment

6.1 CN501, CN502, CN503, CN504 (Connect to Panel Backlight, SM02B-BHSS-1-TB or equivalent)

Pin	Symbol	Description
1	H.V.	High voltage for lamp
2	L.V.	Low voltage for lamp

6.2 CN101 (Power BD to Interface BD)

Pin No.	Symbol	Description
1,2	+5V (VCC5V)	+5.2V output
3,6	GND	Ground
4	BRIGHTNESS	Brightness Control
5	ON/OFF	CCFL on/off Control

6.3 CN106 (Interface BD to Keypad)

Pin No.	Symbol	Description
1	KEY_SELECT/AUTO	Select control and auto adjustment control
2	KEY_MENU/EXIT	OSD page selection and exit
3	KEY_UP	OSD “? ” control to adjust value to increase
4	KEY_POWER	DC power on/off control
5	KEY_DOWN	OSD “? ” control to adjust value to decrease
6	LED_GREEN	Green LED lighting control
7	GND	Ground
8	LED_ORANGE	Orange LED lighting control

6.4 CN103 (Connect I/F BD to panel, FI-X30S-H or Equivalent)

Pin No.	Symbol	Function
1	RXO0-	minus signal of odd channel 0(LVDS)
2	RXO0+	plus signal of odd channel 0(LVDS)
3	RXO1-	minus signal of odd channel 1(LVDS)
4	RXO1+	plus signal of odd channel 1(LVDS)
5	RXO2-	minus signal of odd channel 2(LVDS)
6	RXO2+	plus signal of odd channel 2(LVDS)
7	GND	Ground
8	RXOC-	minus signal of odd clock channel (LVDS)
9	RXOC+	plus signal of odd clock channel (LVDS)
10	RXO3-	minus signal of odd channel 3(LVDS)
11	RXO3+	plus signal of odd channel 3(LVDS)
12	RXE0-	minus signal of even channel 0(LVDS)
13	RXE0+	plus signal of even channel 0(LVDS)
14	GND	Ground

15	RXE1-	minus signal of even channel 1(LVDS)
16	RXE1+	plus signal of even channel 1(LVDS)
17	GND	Ground
18	RXE2-	minus signal of even channel 2(LVDS)
19	RXE2+	plus signal of even channel 2(LVDS)
20	RXEC-	minus signal of even clock channel (LVDS)
21	RXEC+	plus signal of even clock channel (LVDS)
22	RXE3-	minus signal of even channel 3(LVDS)
23	RXE3+	plus signal of even channel 3(LVDS)
24	GND	Ground
25	GND	Ground
26	GND	Ground or Open
27	GND	Ground
28	VCC	Power supply (5.0 V)
29	VCC	Power supply (5.0 V)
30	VCC	Power supply (5.0 V)

6.5 CN102 (D-SUB Connector)

Pin	Symbol	Pin	Symbol	Pin	Symbol
1	Red video input	6	Red GND	11	NC
2	Green video input	7	Green GND	12	Serial data (SDA)
3	Blue video input	8	Blue GND	13	H / H+V SYNC
4	NC	9	+5V(from PC)	14	VSYNC
5	Cable Detect	10	GND	15	Data clock line (SCL)

7. Key Parts Pin Assignment

7.1 IC802 (TOP246Y, Power Control IC)

Pin	Symbol	I/O	Description
1	C	I	Control
2	L	I	Line Sense
3	X	I	External Current Limit
4	S	O	Source of MOSFET(GND)
5	F	I	Frequency
6	D	I	Drain of MOSFET

7.2 IC501 (OZ9910G, CCFL inverter controller IC)

Pin No.	Symbol	I/O	Description
1	NDRV4	O	Bottom MOSFET gate drive output in dual forward converter

2	PGND		High-current power ground
3	NDRV2	O	Bottom MOSFET gate drive output in dual forward converter
4	GND A		Low-current signal ground
5	CT	I	Timing capacitor of high frequency oscillator
6	LCT	I	Timing capacitor of set LPWM frequency
7	ADJ	I	Control command input –DC
8	ENA	I	Enable input
9	VSEN	I	Voltage sense feedback
10	CMP_SST	I	Soft start and loop compensation capacitor
11	ISEN	I	Current sense feedback
12	VREF	O	Reference voltage output
13	VIN	I	Supply voltage for IC
14	HSB	I	High side driver buffer output
15	PDRV3	O	Top MOSFET gate drive output in dual forward converter
16	PDRV1	O	Top MOSFET gate drive output in dual forward converter

7.3 U104 (TSU16AK)

Pin	Symbol	I/O	Description
1	LVBOM	O	B-Link Negative LVDS Differential Data Output
2	GND		Ground
3	BYPASS		For External Bypass Capacitor
4	NC		Not connected
5	NC		Not connected
6	BUSTYPE	IN	Low : Serial bus; High : Direct bus
7	NC		Not connected
8	NC		Not connected
9	NC		Not connected
10	GND		Ground
11	VDDP	O	Digital Output Power
12	NC		Not connected
13	NC		Not connected
14	NC		Not connected
15	NC		Not connected
16	NC		Not connected
17	NC		Not connected
18	VDDC	I	Digital Core Power
19	GND		Ground
20	GND		Ground
21	VDDP	O	Digital Output Power
22	NC		Not connected
23	NC		Not connected
24	NC		Not connected
25	NC		Not connected
26	NC		Not connected
27	NC		Not connected
28	NC		Not connected
29	NC		Not connected
30	AD0	I/O	DDR direct bus AD0; 4mA driving strength
31	AD3	I/O	DDR direct bus AD3; 4mA driving strength
32	HWRESET	I	Hardware reset; active high

33	XIN	I	Crystal Oscillator Input
34	XOUT	O	Crystal Oscillator Output
35	AVDD MPLL		MPLL Power
36	GND		Ground
37	HSYNC0	I	Analog HSYNC input
38	VSYNC0	I	Analog VSYNC input
39	GND		Ground
40	NC		Not connected
41	NC		Not connected
42	GND		Ground
43	NC		Not connected
44	NC		Not connected
45	VDD ADC	I	ADC Power
46	NC		Not connected
47	NC		Not connected
48	GND		Ground
49	NC		Not connected
50	NC		Not connected
51	VDD ADC	I	ADC Power
52	REXT		External resistor 390 ohm to AVDD ADC
53	AVDD PLL	I	PLL Power
54	GND		Ground
55	AVDD ADC	I	ADC Power
56	GND		Ground
57	BINOM	I	Reference ground for analog blue input
58	BINO	I	Analog blue input
59	GINOM	I	Reference ground for analog green input
60	GINO	I	Analog green input
61	SOGINO	I	Sync-on-green input
62	RINOM	I	Reference ground for analog red input
63	RINO	I	Analog red input
64	GND		Ground
65	AVDD ADC	I	ADC Power
66	REFP		Internal ADC top de-coupling pin
67	REFM		Internal ADC bottom de-coupling pin
68	GND		Ground
69	ALE/CS	I	DDR direct bus ALE; active high
70	WRZ/SDA	I/O	DDR direct bus WRZ; active low
71	RDZ/SCL	I	DDR direct bus RDZ; active low
72	INT	O	CPU interrupt; 4mA driving strength
73	PWM0	O	PWM0; 4mA driving strength
74	PWM1	O	PWM1; 4mA driving strength
75	NC		Not connected
76	NC		Not connected
77	AD1	I/O	DDR direct bus AD1; 8mA driving strength
78	AD2	I/O	DDR direct bus AD2; 8mA driving strength
79	NC		Not connected
80	NC		Not connected
81	NC		Not connected
82	NC		Not connected
83	NC		Not connected
84	VDDP	O	Digital Output Power
85	GND		Ground
86	GND		Ground
87	VDDC	I	Digital Core Power
88	NC		Not connected
89	NC		Not connected
90	NC		Not connected

91	NC		Not connected
92	NC		Not connected
93	NC		Not connected
94	VDDP	O	Digital Output Power
95	GND		Ground
96	GND		Ground
97	VDDC	I	Digital Core Power
98	NC		Not connected
99	NC		Not connected
100	NC		Not connected
101	NC		Not connected
102	LVA3P	O	A-Link Positive LVDS Differential Data Output
103	LVA3M	O	A-Link Negative LVDS Differential Data Output
104	VDDP	O	Digital Output Power
105	GND		Ground
106	LVACKP	O	A-Link Positive LVDS Differential Clock Output
107	LVACKM	O	A-Link Negative LVDS Differential Clock Output
108	LVA2P	O	A-Link Positive LVDS Differential Data Output
109	LVA2M	O	A-Link Negative LVDS Differential Data Output
110	LVA1P	O	A-Link Positive LVDS Differential Data Output
111	LVA1M	O	A-Link Negative LVDS Differential Data Output
112	LVA0P	O	A-Link Positive LVDS Differential Data Output
113	LVA0M	O	A-Link Negative LVDS Differential Data Output
114	VDDP	O	Digital Output Power
115	GND		Ground
116	GND		Ground
117	VDDC		Digital Core Power
118	LVB3P	O	B-Link Positive LVDS Differential Data Output
119	LVB3M	O	B-Link Negative LVDS Differential Data Output
120	LVBCKP	O	B-Link Positive LVDS Differential Clock Output
121	LVBCKM	O	B-Link Negative LVDS Differential Clock Output
122	LVB2P	O	B-Link Positive LVDS Differential Data Output
123	LVB2M	O	B-Link Negative LVDS Differential Data Output
124	LVB1P	O	B-Link Positive LVDS Differential Data Output
125	LVB1M	O	B-Link Negative LVDS Differential Data Output
126	VDDP	O	Digital Output Power
127	GND		Ground
128	LVBOP	O	B-Link Positive LVDS Differential Data Output

7.4 U105 (Micro-controller: W78E65P-40)

Pin	Symbol	I/O	Description
1	P4.2/INT3		A bi-directional I/O port with alternate function.
2	P1.0/T2	O	Enable panel power on
3	P1.1/T2EX	O	Enable CCFL work
4	P1.2	I	VGA cable detection
5	P1.3/PWM0	O	provide alternated function of PWM Volume
6	P1.4/PWM1	O	provide alternated function of PWM Green LED lighting control
7	P1.5/PWM2	O	provide alternated function of PWM Orange LED lighting control
8	P1.6/PWM3		Function is the same as that of standard 8052
9	P1.7/PWM4		Function is the same as that of standard 8052
10	RST	I	Reset control pin
11	P3.0/RXD		SCL line of I2C for EDID, debug function
12	P4.3/INT2		PORT 4: A bi-directional I/O port with alternate function.
13	P3.1/TXD		SDA line of I2C for EDID, debug function
14	P3.2/INT0	I	Interrupt request control pin
15	P3.3/INT1	O	Shut Down Volume Mutestandard 8052.
16	P3.4/T0	O	SCL line of I2C communication with EEPROM

17	P3.5/T1	I/O	SDA line of I2C communication with EEPROM
18	P3.6/WR	I	DVI cable detection standard 8052.
19	P3.7/RD	O	EEPROM write protection control for DVI EDID Prevent E2PROM Write instandard 8052.
20	XTAL2		Crystal 22.1184MHz In
21	XTAL1		Crystal 22.1184MHz out
22	GND		Sink voltage ground
23	P4.0		A bi-directional I/O port with alternate function.
24	P2.0/A8		DC power on/off control
25	P2.1/A9		OSD u control to adjust value to increase
26	P2.2/A10		OSD t control to adjust value to decrease
27	P2.3/A11		Selection of menu command listed
28	P2.4/A12		OSD page selection
29	P2.5/A13		Auto adjustment control
30	P2.6/A14		A bi-directional I/O port with internal pull-ups
31	P2.7/A15		A bi-directional I/O port with internal pull-ups
32	PSEN		Program Store Enable
33	ALE		Address Latch Enable
34	P4.1		A bi-directional I/O port with alternate function
35	EA	I	External Access Enableexternal ROM. The ROM address and data will not be presented on the bus ifthe EA pin is high and the program counter is within the 64 KB area.
36	P0.7/AD7	I/O	DDR Direct Bus Communication with Scaler
37	P0.6/AD6	I/O	DDR Direct Bus Communication with Scaler
38	P0.5/AD5	I/O	DDR Direct Bus Communication with Scaler
39	P0.4/AD4	I/O	DDR Direct Bus Communication with Scaler
40	P0.3/AD3	I/O	WRZ line of DDR Direct Bus
41	P0.2/AD2	I/O	RDZ line of DDR Direct Bus
42	P0.1/AD1	I/O	ALE line of DDR Direct Bus
43	P0.0/AD0	O	Hardware reset to Scaler
44	+5V	I	+5V for MCU working voltage

5. Adjustment Procedure

Equipment Needed

- SIGNAL GENERATOR
- MULTIMETER
- SCREW DRIVER
- OSCILLOSCOPE
- Soldering IRON
- SOLDER
- VGA Cable (Black, 15pins point to point)
- Color Analyzer
- ISP Board
- EDID Board
- FOXISP. EXE file
- EDID program file
- Power Adapter output 5V/2A

Burn-in pattern

If it is a new monitor, and in factory mode, if no VGA signal input, Burn-in pattern will self generate automatically. Burn in patterns are: full Red, Green, Blue, White and Black. You can not escape from Burn-in pattern until plug in VGA Cable, and then press the power key. Turn the monitor off and then turn it on.

Auto Color (Automatically calibrate chip ADC parameter by using chip internal DAC)

If it is a new-built set and it is first time to do the “auto color”, please confirm the following steps:

- Connect the VGA cable with the standard video pattern generator and display 16-gray pattern on the monitor.
- Press “Power” to power off the monitor.
- Press” []+[]+[⏻] “simultaneously to enter factory mode.
- Press “Menu[1]”, then press “Auto[2]” to execute Auto color item.
- After the “Auto Color” process finished, please press “Power” to restart monitor.

EDID (Rewrite EDID data to EEPROM)

If we need to rewrite the EEPROM data, please confirm the following steps.

1. Plug in VGA Cable; we can rewrite the EDID data to EEPROM by using “EDID Rewrite” program.
2. If the “EDID Rewrite” process finished, please pull out VGA cable and press “ 2 ” +“ ”at the same time.
3. Pull out AC power cable or press power key to restart.

Upload firmware to MCU via VGA Cable

1. Connect ISP board between monitor and PC as below configure

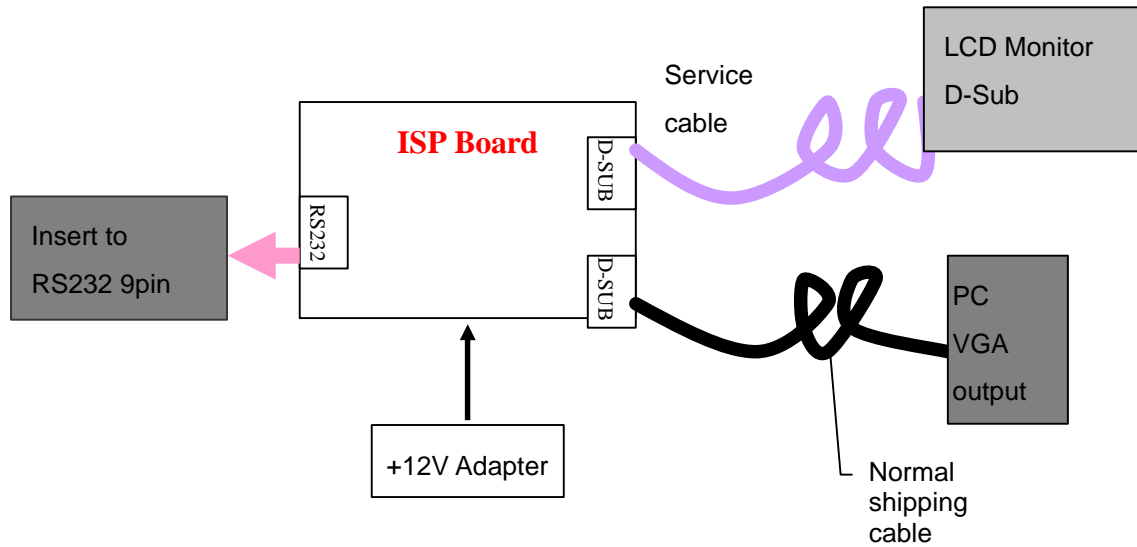

2. Before plug in the power cord, make sure keep “ ” key to be pressed, when power on you can enter ISP mode.
3. 8051ispwriter.exe will detect automatically which MCU used in this monitor. Do it as the order shown on the screen, choose the corresponding firmware version, and load to MCU.
4. After finish, please plug out power cable and re-start monitor again.

After repair, to ensure the quality you should do the following test and adjustment

Item	Content	Equipment
Test OSD function	1.Signal is set as 1280x1024@60Hz 2. LCM button are from left to right, checking whether each single function key and compound function key can be worked.	Chroma Signal Generator
Contrast Check	1. Set input mode to 1280x1024@60Hz 2. Set Pattern to 32 gray shades 3. Set contrast to the max. The brightest 5~6 shades brightness cannot be distinguished.	Chroma Signal Generator
Color Temperature	1. Do “Auto color” at 1280 x 1024@60Hz, 32gray shades 2. Measure color temperature, check it complies with the following temperature: 5400K x=0.335 +/- 0.02, y=0.350 +/- 0.02 6500K x=0.313 +/- 0.02, y=0.329 +/- 0.02 9300K x=0.283 +/- 0.02, y=0.298 +/- 0.02	Chroma Signal Generator and color analyzer

Modes switching check	<ol style="list-style-type: none"> 1. Use Chroma Pattern Generator to make sequence. VESA (640x480 800x600 1024x768 1280x1024), MAC 832x624 DOS (640x350 720x400), the detail supported modes and power saving signal. 2. Confirm the above timing modes must be full screen and the picture must be normal. 3. LED is Orange at power saving mode. 	Chroma Signal Generator												
Y measurement at default setting	<ol style="list-style-type: none"> 1. Set brightness to default value 100 and contrast to default value 70 at 6500K 2. At full white patten, Measure Y, which should be 250+/-10cd/m² (QDI 220+/- 10cd/m²) 	Chroma Signal Generator and Color Analyzer												
Panel Flicker check	<ol style="list-style-type: none"> 1. Mode: 1280x1024@60Hz 2. Set Brightness& contrast to default value 3. Do "Auto Image Adjust" 4. Shut down PC to check whether there's glitter on the center of the picture. 	Equipment:: Chroma Signal Generator & PC												
Power saving	<ol style="list-style-type: none"> 1. Mode: 1280x1024@60Hz 2. Pattern: full white 3. Brightness: Max. 4. Contrast: Default 5. Check power consumption at each modes 	Chroma signal generator and Power meter AC input: 230V/50Hz												
	<table border="1"> <thead> <tr> <th data-bbox="357 786 628 860">State</th> <th data-bbox="628 786 911 860">Power Consumption</th> <th data-bbox="911 786 1182 860">LED color</th> </tr> </thead> <tbody> <tr> <td data-bbox="357 860 628 898">Normal</td> <td data-bbox="628 860 911 898">< 38W</td> <td data-bbox="911 860 1182 898">Green</td> </tr> <tr> <td data-bbox="357 898 628 936">Stand By</td> <td data-bbox="628 898 911 936">< 1W</td> <td data-bbox="911 898 1182 936">Orange</td> </tr> <tr> <td data-bbox="357 936 628 976">Power Key Off</td> <td data-bbox="628 936 911 976">< 1W</td> <td data-bbox="911 936 1182 976">No</td> </tr> </tbody> </table>		State	Power Consumption	LED color	Normal	< 38W	Green	Stand By	< 1W	Orange	Power Key Off	< 1W	No
	State		Power Consumption	LED color										
	Normal		< 38W	Green										
	Stand By		< 1W	Orange										
Power Key Off	< 1W	No												

Disassembly Block

VA702 (INL PANEL)DIS-ASSEMBLY BLOCK

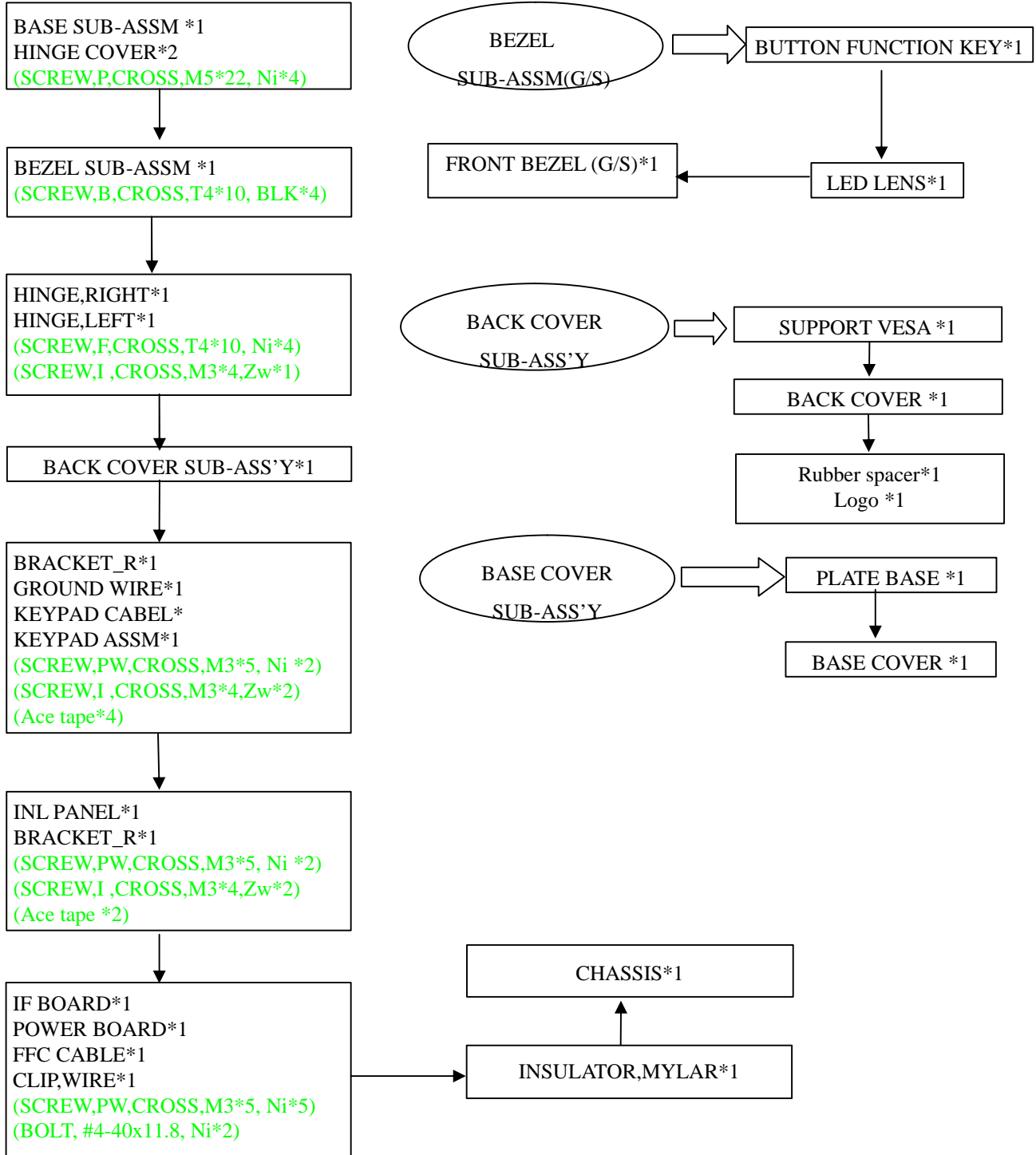

Note: Arrows are disassembly directions.

Assembly Block

VA702 (INL panel)ASSEMBLY BLOCK

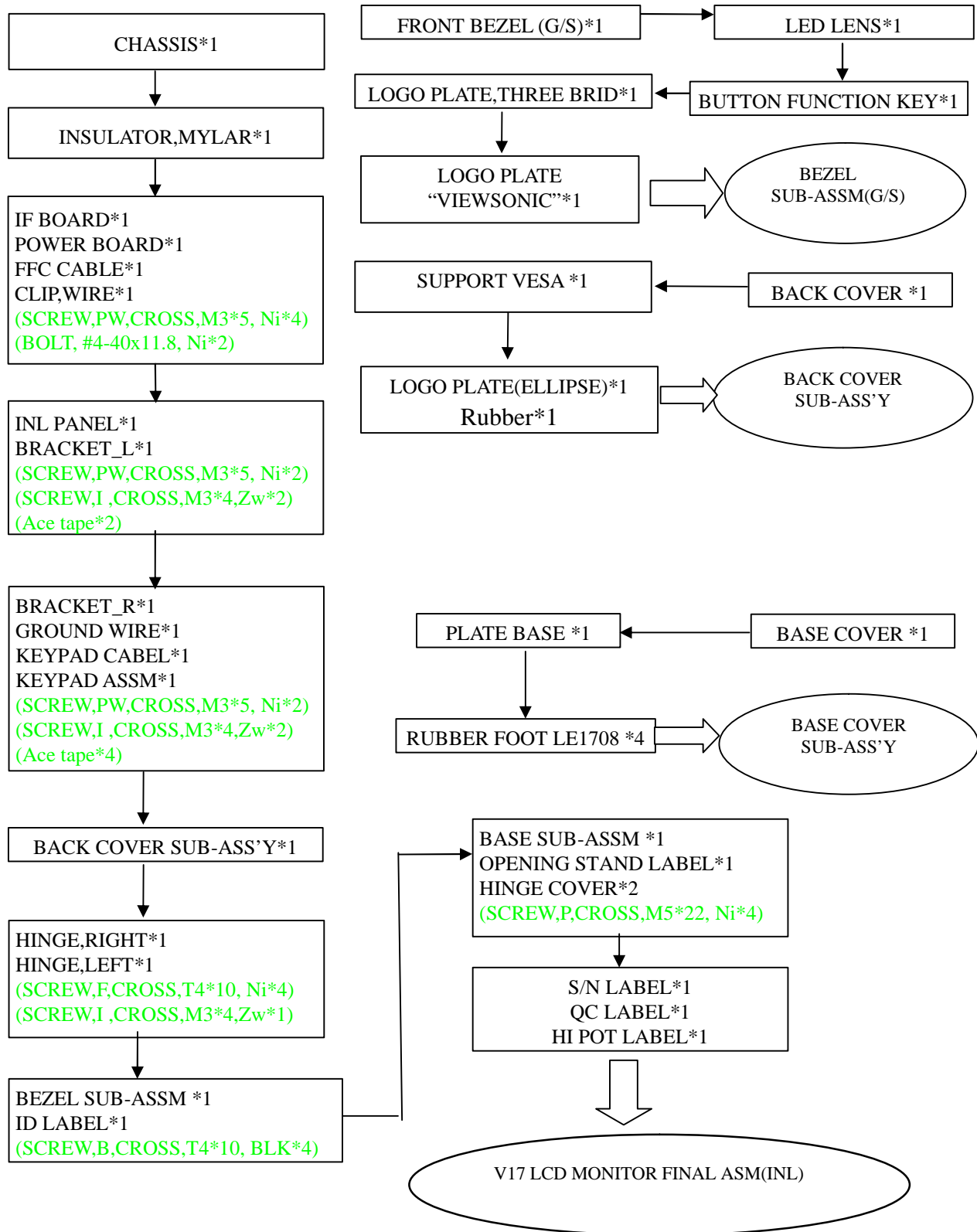

Note: Arrows are assembly directions.

6. Troubleshooting Flow Chart

1. Common Acknowledge

- If you change the interface board, be sure that the U105, U106 and U103 these three components also changed to the new I/F board because there was program inside. If not, please re-write EDID or upload firmware into MCU via VGA Cable.
- If you adjust clock and phase, please do it at the condition of Windows shut down pattern.
- If you confirm the R.G.B. color is normal or not, please do it under 16-grey scalar pattern.
- This LCM is analog interface. So if the entire screen is an abnormal color that means the problem happen in the analog circuit part, if only some scale appears abnormal color that stand the problem happen in the digital circuit part.
- If you check the H/V position, please use the crosshatch pattern.
- This LCM support more than 30 timing modes, if the input timing mode is out of specification, the picture may appears abnormally.
- If brightness uneven, repairs Inverter circuit or change a new panel.
- If you find the vertical line or horizontal line lost on the screen, please change panel.

2. No Power & Power LED Off

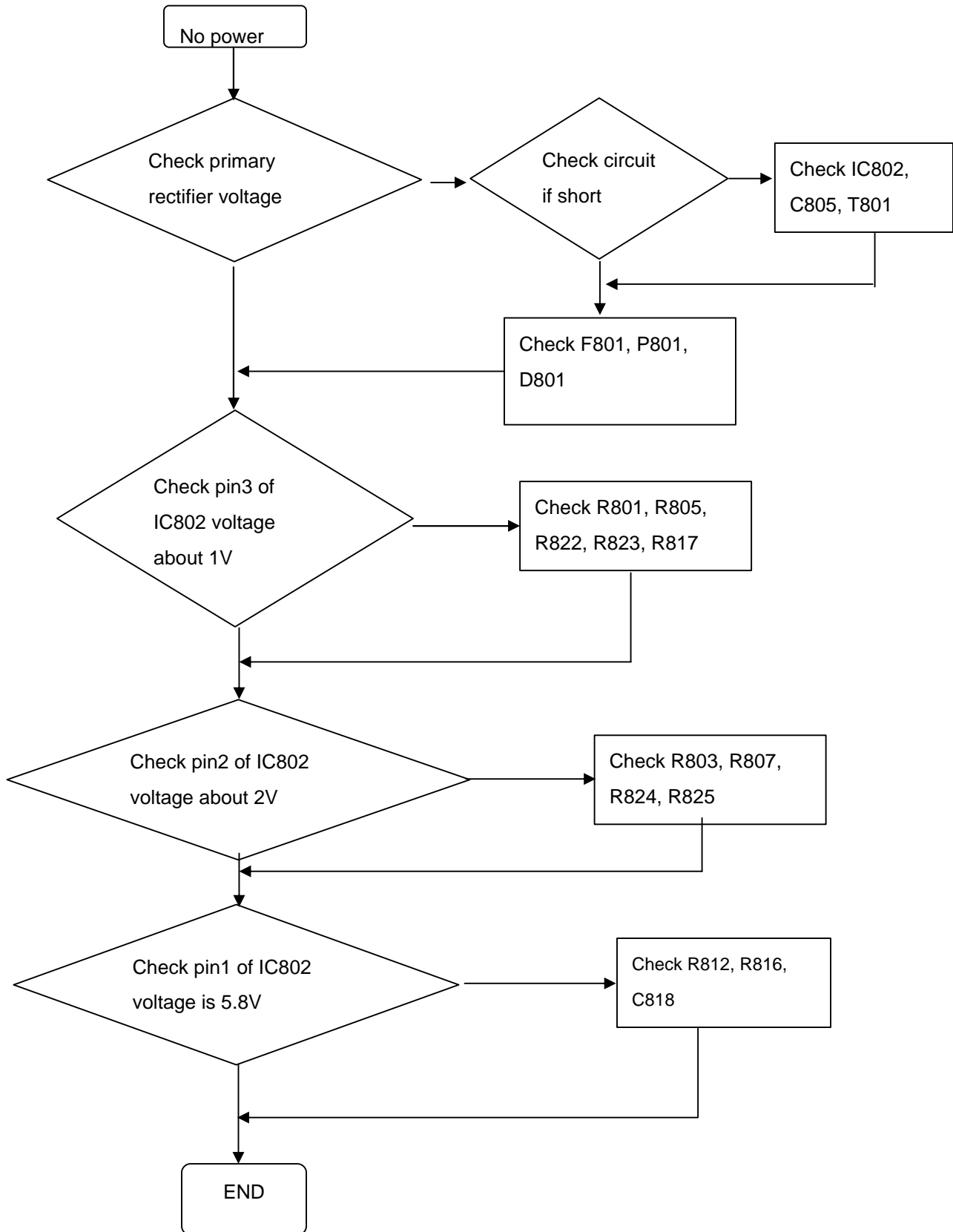

3. DC output voltage is unstable

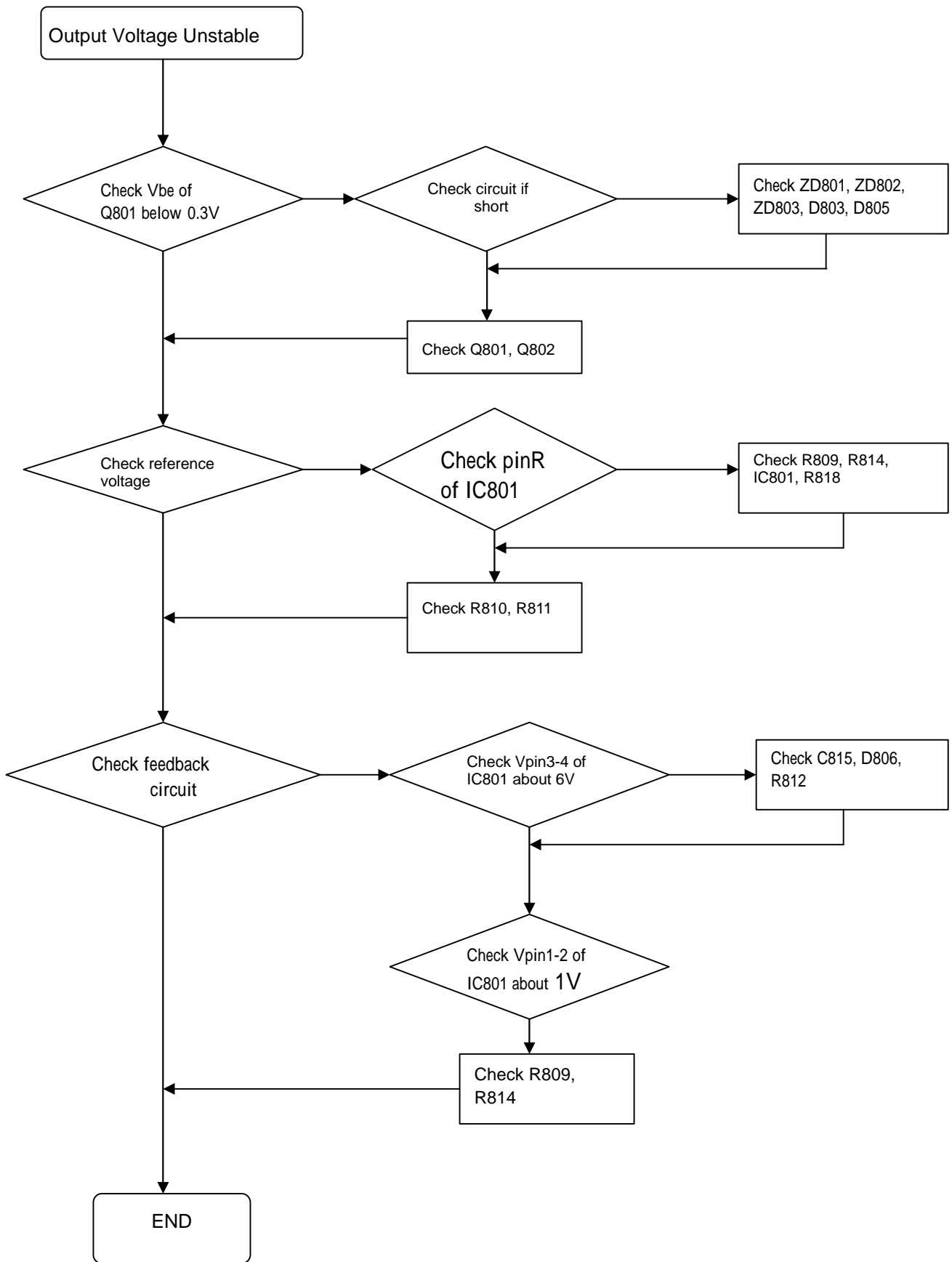

4. Output power is unstable

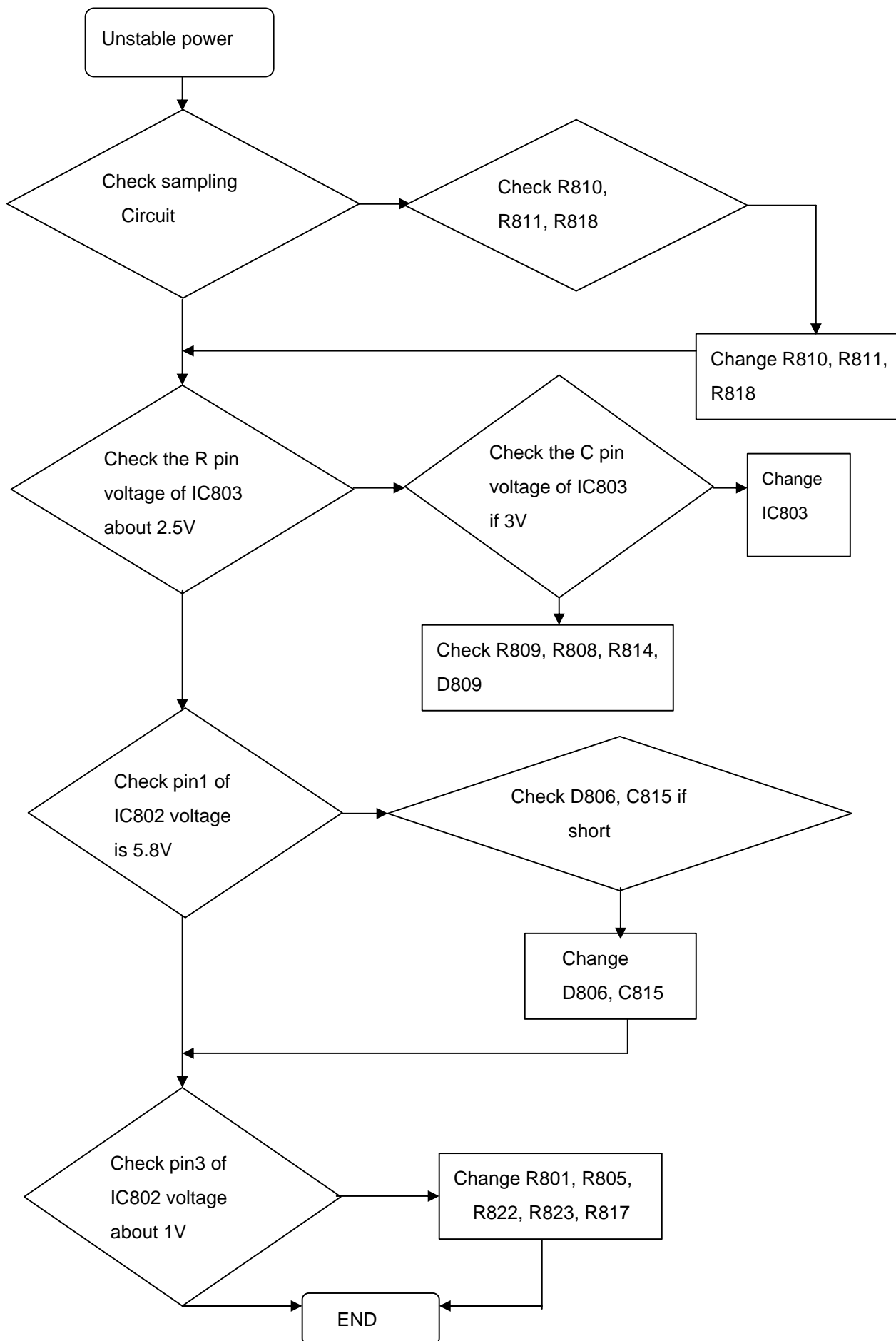

5. Backlight can't be turned on

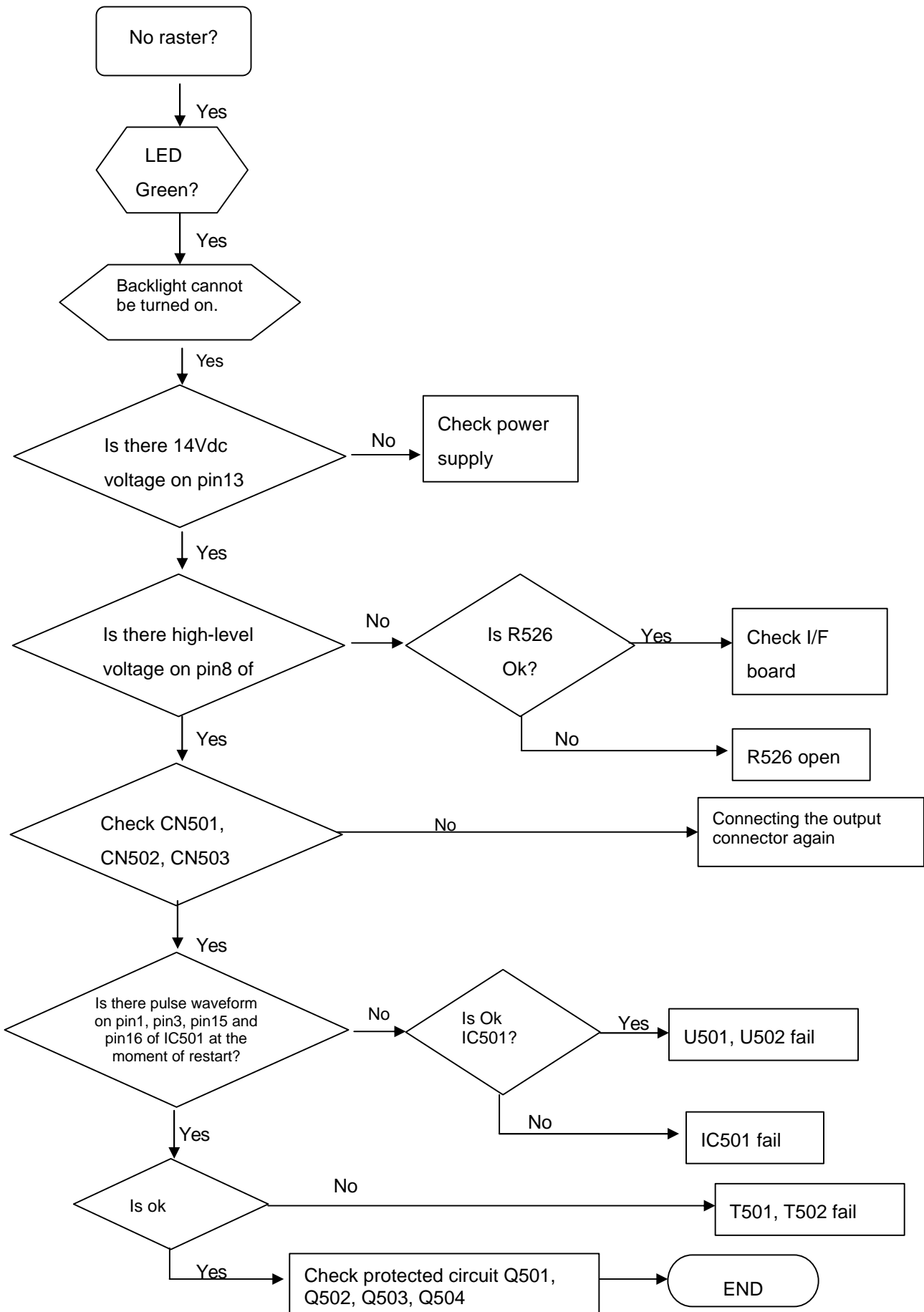

6. Black Screen and backlight turn on

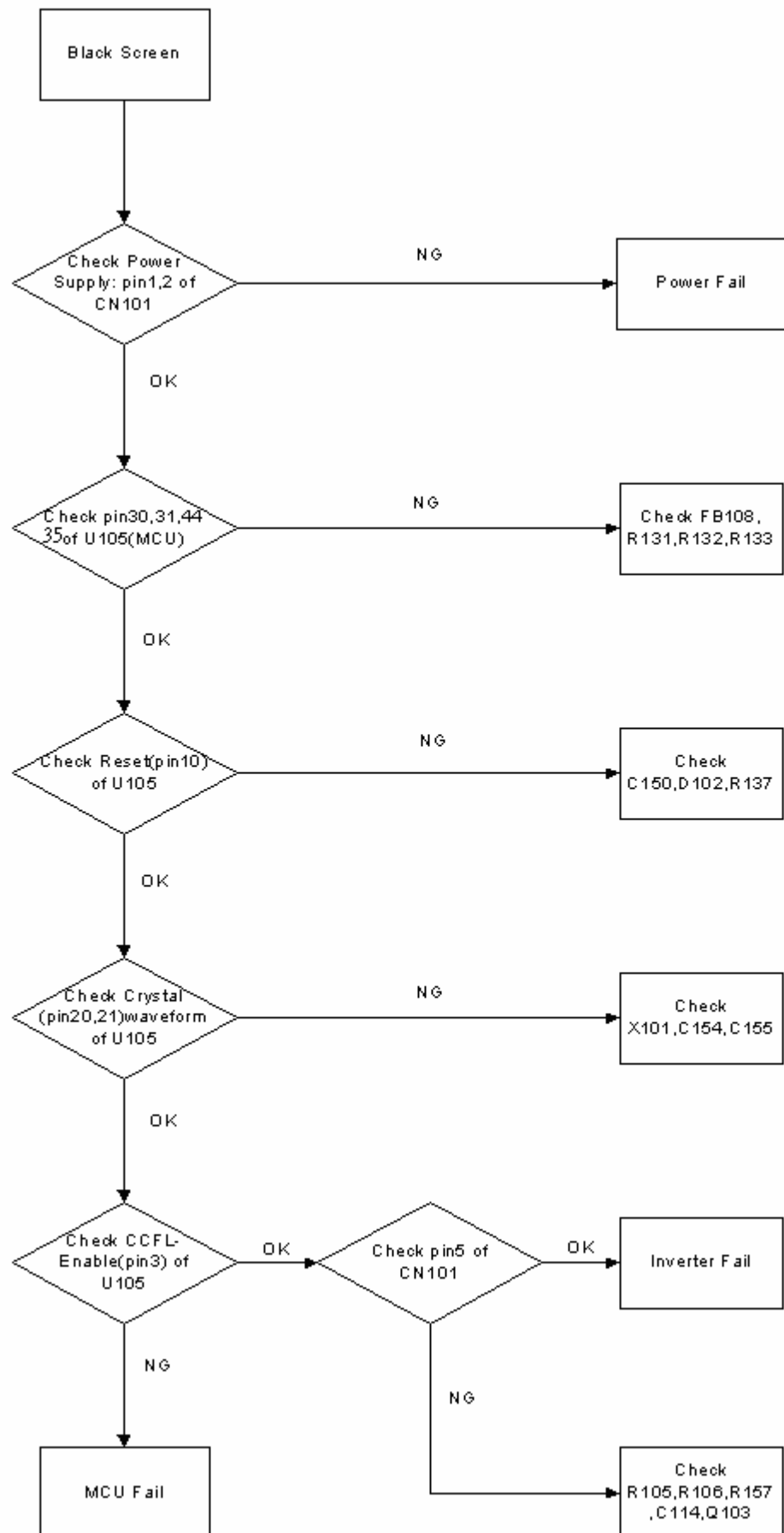

7. White Screen

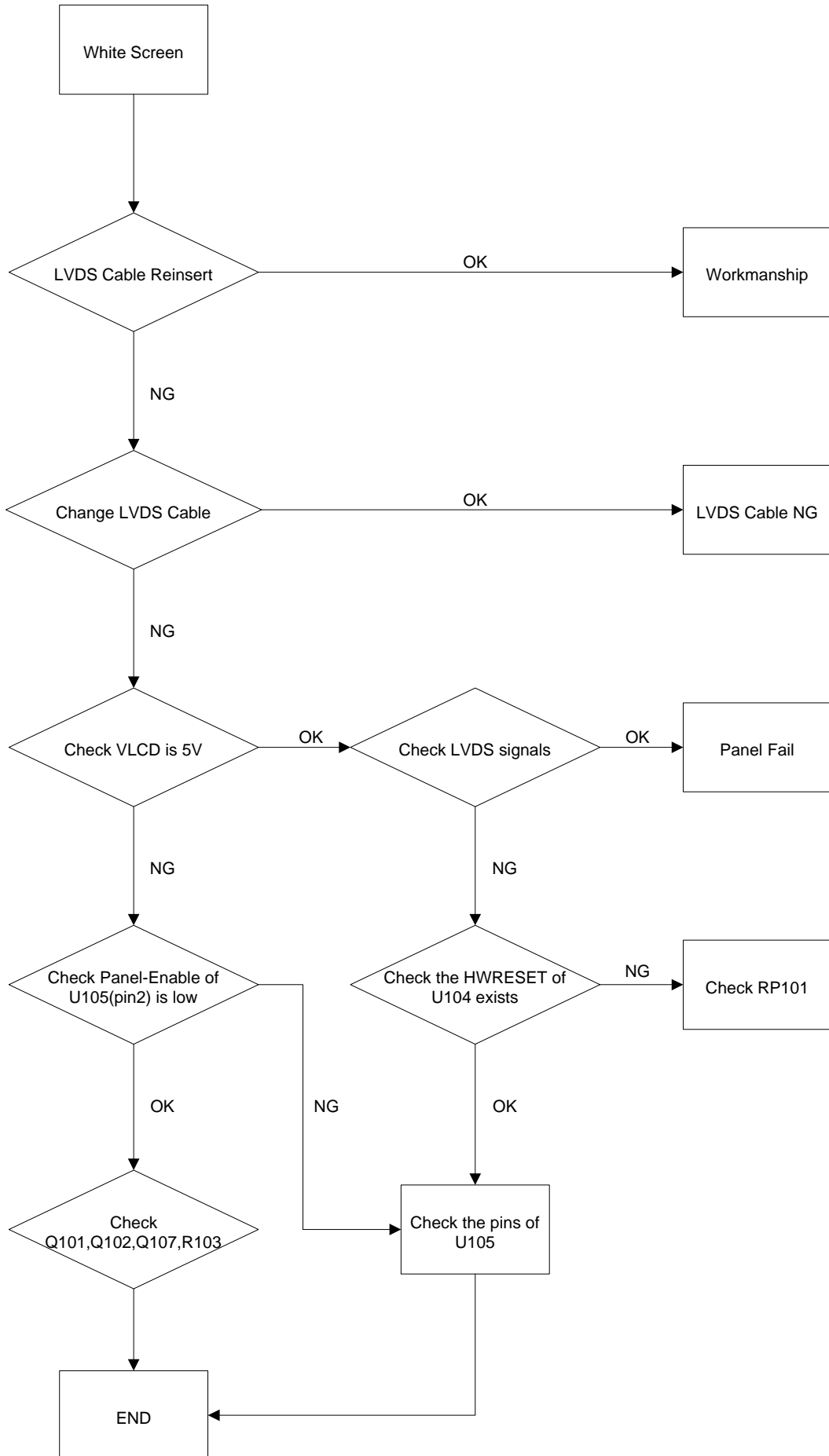

8. Bad Screen

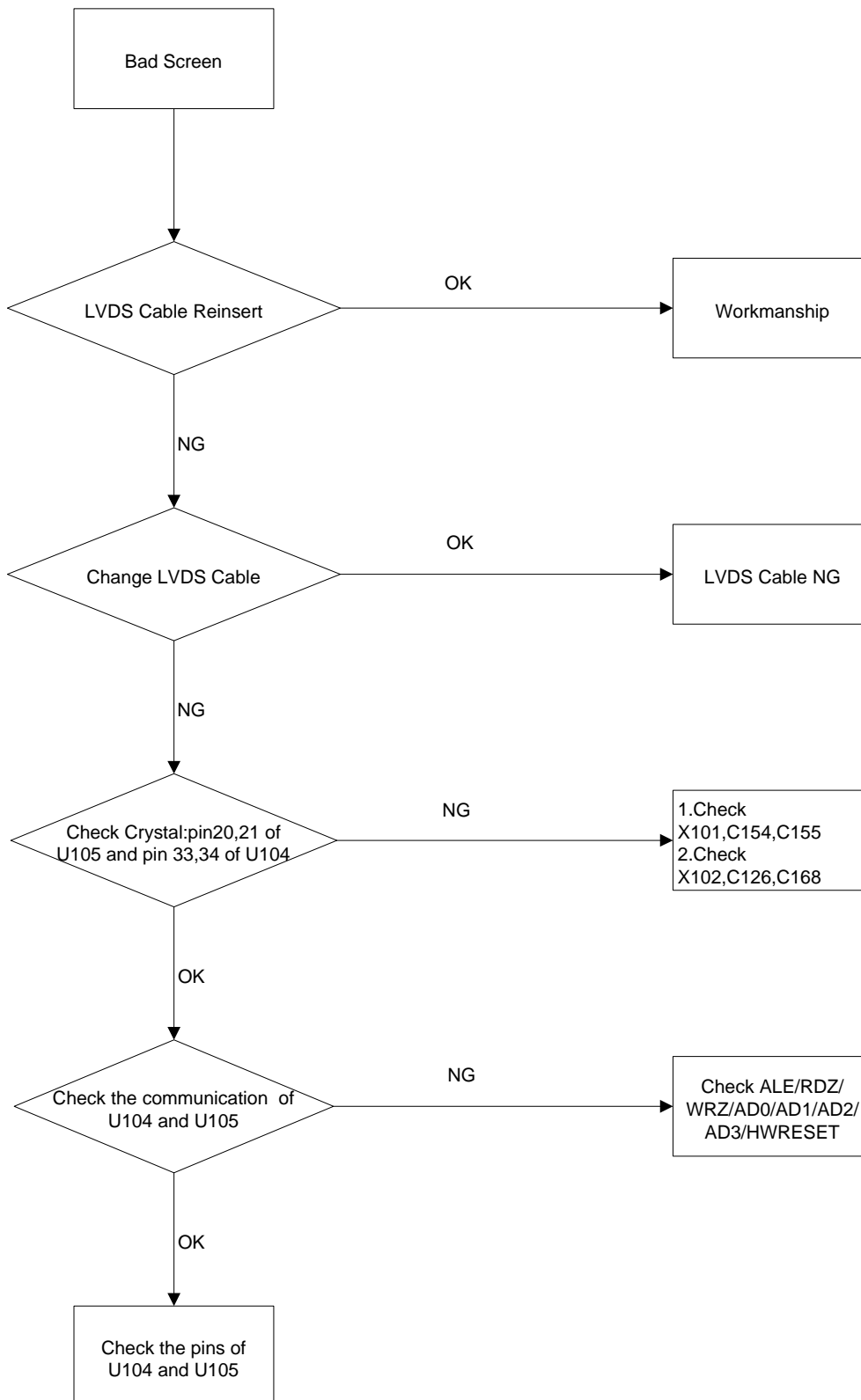

7. Recommended Spare Parts List

RECOMMENDED SPARE PARTS LIST (VA702-2)

ViewSonic Model Number: VS10781

Rev: 1b

Serial No. Prefix: Q4E

Item	Description	ECR/ECN	ViewSonic P/N	Ref. P/N	Location	Universal number#
1	Accessories:					
	Power Cord 10A/250V BLK 6FT CHINA		A-00005255	453070800170R		
2	Kit Accessory		A-00005274	703000000506R		
3	Board Assembly:					
	Key Board RoHS		B-00005278	790411500000R		
4	Power Board RoHS		B-00005279	790411400600R		
5	Interface Board (V4/G3), LE1709- 6A0 ROHS		B-00005280	790411300620R		
6	Interface Board (V7), LE1709- 6A0 ROHS	Added on 09/05/06	B-00008066	790411300630R		
7	Cabinets:					
	Base Assembly		C-00005262	714020002400R		
8	Front Panel		C-00005263	714030002400R		
9	Back Cover		C-00005264	714050002400R		
10	Cables:					
	Cable D-Sub 15P MALE 6FT BLACK/BLUE,SZ40		CB-00005254	453010100100R		
11	Flat Cable 30P 234mm,RoHS		CB-00005259	430303000140R		
12	Flat Cable 4x2P 189mm		CB-00005260	430300800320R		
13	Flat Cable - 137mm RoHS		CB-00005261	430300100210R		
14	Electronic Components:					
	LCD PANEL 17" MT170EN01-V4-G1,AM17000054		E-00005275	631102071060R		
15	LCD PANEL 17" MT170EN01-V7-G1,AM17000057	Added on 09/05/06	E-00008006	631102071910R		
16	LCD PANEL 17" MT170EN01-V7-G2,AM17000057	Added on 09/05/06	E-00008007	631102071920R		
17	LCD PANEL 17" MT170EN01-V7-G3,AM17000057	Added on 09/05/06	E-00008008	631102071930R		
18	Hardware:					
	Hinge Cover		HW-00005258	501020203000R		
19	Screw,B,Cross,T.T-4*10,BLK ,ROHS		HW-00005265	509412610500R		
20	Screw,F,Cross,T.T-4*10,Ni ROHS		HW-00005266	509212610300R		
21	Screw,P,Cross,M5*22,Ni,ROHS		HW-00005267	509116822300R		
22	Screw,I,Cross,M3*4,Zw,ROHS		HW-00005268	509016304102R		
23	Screw,PW,Cross,W/WAS,M3*5,N1		HW-00005269	509146305300R		
24	Bolt,#4-40x11.8,Ni FOR D-SUB/DVI		HW-00005270	509000000700R		
25	Screw,I,Cross,M3*4,Zw,ROHS		HW-00005271	509016304102R		
26	Hinge,Right, LE1709		HW-00005276	502060401910R		
27	Hinge,Left, LE1709		HW-00005277	502060401900R		
28	Packing Material:					
	Foam (Right)		P-00005253	506040005510R		
29	Craft Box		P-00005256	506020006800R		
30	Foam (Left)		P-00005257	506040005500R		
31	Bag,Pe+Epe,L590xW480xT0.6mm (PRINTED)LE1		P-00005272	506120300400R		
32	BAG,PLASTIC,1690xW(455+145)xT0.05mm, LE1		P-00005273	506120004500R		

Remark 1: Above listed items are examples, supplier can expand the rows to add more necessary items.

Remark 2: All revised RSPLs with newly added items or any change made should be highlighted and correlated with the ECN/ECR approved by ViewSonic Corporation. This is to eliminate repeated cross checks of each item between this version and prior versions.

RECOMMENDED SPARE PARTS LIST (VA721-3)

ViewSonic Model Number: VS10781

Serial No. Prefix: Q7P

Rev: 1b

Item	Description	ECR/ECN	ViewSonic P/N	Ref. P/N	Location	Universal number#
1	Accessories: PWRCORD 10A/250V BLK 6FT CHINA.RVV 3Gx0.		A-00005255	453070800170R		
2	Board Assembly: PCBA,KEYPAD BOARD, LE1709 ROHS		B-00005278	790411500000R		
3	PCBA,PWR&INV./B, LE1709-6A0 ROHS		B-00005279	790411400600R		
4	PCBA,IF BOARD(V4/G3), LE1709- 6A0 ROHS		B-00005280	790411300620R		
5	PCBA,IF BOARD(V7), LE1709- 6A0 ROHS	Added on 09/11/06	B-00008066	790411300630R		
6	Cabinet: ASSY,BASE, LE1709		C-00005262	714020002400R		
7	ASSY,BACK COVER, LE1709		C-00005264	714050002400R		
8	ASSY,BEZEL(S),VA721,LE1709		C-00005291	714030002420R		
9	Cable: CABLE,D-SUB 15P MALE 6FT BLACK/BLUE.SZ4(CB-00005254	453010100100R		
10	HRN LVDS FFC 30P 234mm,RoHSACCX30234KU28		CB-00005259	430303000140R		
11	HRN ASS'Y 4x2P 189mm UL2651#28SZ504479B.		CB-00005260	430300800320R		
12	HRN ASS'Y 1P 137mm BLACK,UL100 7 #20,RoF		CB-00005261	430300100210R		
13	Electronics: LCD PANEL 17" MT170EN01-V4-G1,AM17000054		E-00005275	631102071060R		
14	LCD PANEL 17" MT170EN01-V7-G1,AM17000057	Added on 09/11/06	E-00008006	631102071910R		
15	LCD PANEL 17" MT170EN01-V7-G2,AM17000057	Added on 09/11/06	E-00008007	631102071920R		
16	LCD PANEL 17" MT170EN01-V7-G3,AM17000057	Added on 09/11/06	E-00008008	631102071930R		
17	HardWare: COVER,HINGE, LE1709		HW-00005258	501020203000R		
18	SCREW,B,CROSS,T.T-4*10,BLK ,ROHS		HW-00005265	509412610500R		
19	SCREW,F,CROSS,T.T-4*10,Ni ROHS		HW-00005266	509212610300R		
20	SCREW,P,CROSS,M5*22,Ni,ROHS		HW-00005267	509116822300R		
21	SCREW,I,CROSS,M3*4,Zw,ROHS		HW-00005268	509016304102R		
22	SCREW,I,CROSS,M3*4,Zw,ROHS		HW-00005268	509016304102R		
23	SCREW,PW,CROSS,W/WAS,M3*5,Ni		HW-00005269	509146305300R		
24	BOLT,#4-40x11.8,Ni FOR D-SUB/DVI CONN.RC		HW-00005270	509000000700R		
25	HINGE,RIGHT, LE1709		HW-00005276	502060401910R		
26	HINGE,LEFT, LE1709		HW-00005277	502060401900R		
27	Packing Material: FOAM, CUSHION,EPS-R, LE1709		P-00005253	506040005510R		
28	FOAM, EPS-L, LE1709		P-00005257	506040005500R		
29	BAG,PE+EPE,L590xW480xT0.6mm (PRINTED)LE1		P-00005272	506120300400R		
30	BAG,PLASTIC,1690xW(455+145)xT0.05mm, LE1		P-00005273	506120004500R		
31	BOX, CARTON,VA721, LE1709		P-00005289	506020006820R		

RECOMMENDED SPARE PARTS LIST (VA721b-3)

ViewSonic Model Number: VS10781

Serial No. Prefix: Q84

Rev: 1b

Item	Description	ECR/ECN	ViewSonic P/N	Ref. P/N	Location	Universal number#
1	Accessories: Power Cord, 10A/250V BLK 6FT RVV 3Gx0 China		A-00005255	453070800170R		
2	KIT,ACCESSORY,-INL V4,LE1709		A-00005292	703000000536R		
3	Board Assembly: Key Board, PCBA LE1709 ROHS		B-00005278	790411500000R		
4	Inverter Board, PCBA LE1709-6A0		B-00005279	790411400600R		
5	Sub Board, IF BOARD (V4/G3), LE1709- 6A0		B-00005280	790411300620R		
6	PCBA,IF BOARD(V7), LE1709- 6A0 ROHS	Added on 09/11/06	B-00008066	790411300630R		
7	Cabinet: Base Assembly, Assy Base		C-00005262	714020002400R		
8	Back Cover		C-00005264	714050002400R		
9	FRONT PANEL, Ass'y Bazel (G), VA721b		C-00005290	714030002430R		
10	Hinge Cover		C-00006088	501020203000R		
11	Cable: Cable, D-Sub , SZ40 RoHS		CB-00005254	453010100100R		
12	Flat Cable, 30P 234mm RoHS		CB-00005259	430303000140R		
13	Wire, HRN ASS'Y 4x2P 189mm UL2651		CB-00005260	430300800320R		
14	Wire, Hrn Ass'y 1P 137mm Black UL100 7 RoHS		CB-00005261	430300100210R		
15	Electronics: LCD Module, 17" MT170EN01- AM17000054		E-00005275	631102071060R		
16	LCD PANEL 17" MT170EN01-V7-G1,AM17000057	Added on 09/11/06	E-00008006	631102071910R		
17	LCD PANEL 17" MT170EN01-V7-G2,AM17000057	Added on 09/11/06	E-00008007	631102071920R		
18	LCD PANEL 17" MT170EN01-V7-G3,AM17000057	Added on 09/11/06	E-00008008	631102071930R		
19	HardWare: Screw B Cross T T-4*10 BLK		HW-00005265	509412610500R		
20	Screw, F Cross T T-4*10 Ni RoHS		HW-00005266	509212610300R		
21	Screw, P Cross M5*22 Ni RoHS		HW-00005267	509116822300R		
22	Screw, PW Cross W/WAS M3*5 Ni RoHS		HW-00005269	509146305300R		
23	Screw, (Bolt) #4-40x11.8,Ni FOR D-SUB RoHS		HW-00005270	509000000700R		
24	SCREW,I,CROSS,M3*4,Zw,ROHS		HW-00005271	509016304102R		
25	Hinge, Right LE1709		HW-00005276	502060401910R		
26	Hinge, Left LE1709		HW-00005277	502060401900R		
27	Packing Material: Foam, Cushion EPS-R LE1709		P-00005253	506040005510R		
28	Foam, Cushion, EPS-L LE1709		P-00005257	506040005500R		
29	PE Bag +EPE, L590xW480xT0.6mm		P-00005272	506120300400R		
30	Bag, Plastic 1690xW(455+145)xT0.05mm, LE1		P-00005273	506120004500R		
31	Craft Box VA721b		P-00005288	506020006830R		

Remark 1: Above listed items are examples, supplier can expand the rows to add more necessary items.

Remark 2: All revised RSPLs with newly added items or any change made should be highlighted and correlated with the ECN/ECR approved by ViewSonic Corporation. This is to eliminate repeated cross checks of each item between this version and prior versions.

BOM LIST (VA702-2)

ViewSonic Model Number: VS10781

Rev: 1b

Serial No. Prefix: Q4E

Item	ViewSonic P/N	Ref. P/N	Description	Location	Universal number#	Q'ty
1	B-00005278	790411500000R	PCBA,KEYPAD BOARD, LE1709 ROHS	For VSCN		1
2	B-00005279	790411400600R	PCBA,PWR&INV./B, LE1709-6A0 ROHS	For VSCN		1
3	B-00008066	790411300630R	PCBA,IF BOARD(V7), LE1709- 6A0 ROHS	For VSCN		1
4	N/A	71408276B100R	ASSY,PANEL(V7/G1&2&3),LE1709-6A0	For VSCN		1
5	N/A	71407276B100R	ASSY,FIANL(S,V7/G1&2&3),LE1709-6A0	For VSCN		1
6	C-00005264	714050002400R	ASSY,BACK COVER, LE1709	For VSCN		1
7	C-00005263	714030002400R	ASSY,BEZEL(S),LE1709	For VSCN		1
8	C-00005262	714020002400R	ASSY,BASE, LE1709	For VSCN		1
9	A-00005274	70300000506R	KIT,ACCESSORY,VA702-INL ,LE1709	For VSCN		1
10	E-00008008	631102071930R	LCD PANEL 17" MT170EN01-V7-G3,AM17000057	For VSCN		1
11	E-00008007	631102071920R	LCD PANEL 17" MT170EN01-V7-G2,AM17000057	For VSCN		1
12	E-00008006	631102071910R	LCD PANEL 17" MT170EN01-V7-G1,AM17000057	For VSCN		1
13	N/A	511100001500R	CLIP,WIRE.CH-01(P/G), LE1709	For VSCN		1
14	HW-00005265	509412610500R	SCREW,B,CROSS,T.T-4*10,BLK ,ROHS	For VSCN		4
15	HW-00005266	509212610300R	SCREW,F,CROSS,T.T-4*10,Ni ROHS	For VSCN		4
16	HW-00005269	509146305300R	SCREW,PW,CROSS,W/WAS,M3*5,Ni	For VSCN		9
17	HW-00005267	509116822300R	SCREW,P,CROSS,M5*22,Ni,ROHS	For VSCN		4
18	HW-00005271	509016304102R	SCREW,I,CROSS,M3*4,Zw,ROHS	For VSCN		4
19	HW-00005270	509000000700R	BOLT,#4-40x11.8,Ni FOR D-SUB/DVI CONN.RO	For VSCN		2
20	N/A	506440003000R	LABEL,BLANK,35x8mm, LE1709 ROHS	For VSCN		2
21	N/A	506440002600R	LABEL,BLANK,210x65mm,LE1709(PALLET)	For VSCN		0.02778
22	N/A	506440002400R	LABEL,BLANK,50x25mm,LE1709(S/N)	For VSCN		1
23	N/A	506440002300R	LABEL,BLANK,76.2x76.2mm,LE1709(UPC)	For VSCN		1
24	N/A	506431000300R	FILM,PE 500mmx900M	For VSCN		0.0004
25	N/A	506390500100R	LABEL,ENERGY STAR, LE1709	For VSCN		1
26	N/A	506390210110R	LABEL,CARTON(8ms),PRC, LE1709	For VSCN		1
27	N/A	506390000600R	LABEL,HI-POT PASS, LE1709	For VSCN		1
28	N/A	506390000500R	LABEL,QC-PASS,OD=15mm, LE1709	For VSCN		1
29	N/A	506390000400R	LABEL,OPENING STAND, LE1709	For VSCN		1
30	N/A	506381000700R	TAPE,ACE,45mmx30M(PC=10x45mm),LE1709	For VSCN		0.001
31	N/A	506380002100R	TAPE,WRAPPING TYPE(VIEWSONIC),50mmx75M,L	For VSCN		0.00513
32	N/A	506380001800R	TAPE,WRAPPING TYPE,48mmx50M LE1X04/05	For VSCN		0.004
33	N/A	506250005102R	LBL,AGENCY(VA702), LE1709(KOREA MARK)	For VSCN		1
34	N/A	506150001310R	PALLET,1120x980x120mm,LE1709	For VSCN		0.01389
35	P-00005272	50612000400R	BAG,PE+EPE,L590xW480xT0.6mm (PRINTED)LE1	For VSCN		1
36	P-00005273	506120004500R	BAG,PLASTIC,l690xW(455+145)xT0.05mm, LE1	For VSCN		1
37	N/A	506102000500R	LOGO PLATE,VIEWSONIC, LE1709(ELLIPSE)	For VSCN		1
38	N/A	506102000400R	LOGO PLATE,VIEWSONIC, LE1709(THREE BIRDS)	For VSCN		1
39	N/A	506102000300R	LOGO PLATE,VIEWSONIC, LE1709	For VSCN		1
40	N/A	506092001400R	CARD,WARRANTY, LE1709	For VSCN		1
41	N/A	506091000500R	LABEL,WARRANTY, LE1709	For VSCN		1
42	P-00005253	506040005510R	CUSHION,EPS-R, LE1709	For VSCN		1
43	P-00005257	506040005500R	CUSHION,EPS-L, LE1709	For VSCN		1
44	N/A	506039002301R	CORNER PAPER,2050x50x50xT3mm,LE1705	For VSCN		0.05556
45	N/A	506039001200R	CORNER PAPER,820x50x50mm	For VSCN		0.0556
46	N/A	506037003700R	CARDBOARD,COVER,L1120xW980xH120xT5mm,LE1	For VSCN		0.02778
47	N/A	506030200200R	CARD,AFTER SERVICE, LE1709.L130xW80	For VSCN		1
48	P-00005256	506020006800R	CARTON,VA702, LE1709	For VSCN		1
49	N/A	505040202000R	INSULATOR,MYLAR,L79.7xW62.7mm,CHASSIS, L	For VSCN		1
50	N/A	503020002600R	RUBBER,FOOT,OD14.1xT2.5mm,3M, LE1708	For VSCN		4
51	N/A	503010001700R	RUBBER,SPACER,L25xW10xT4.0mm,LE1709	For VSCN		1
52	N/A	502170300400R	PLATE,BASE,LE1709	For VSCN		1
53	N/A	502090301300R	CHASSIS, LE1709	For VSCN		1
54	N/A	502080300300R	SUPPORT,VESA, LE1709	For VSCN		1
55	HW-00005276	502060401910R	HINGE,RIGHT, LE1709	For VSCN		1
56	HW-00005277	502060401900R	HINGE,LEFT, LE1709	For VSCN		1
57	N/A	502020300710R	BRACKET,RIGHT, LE1709	For VSCN		1
58	N/A	502020300700R	BRACKET,LEFT, LE1709	For VSCN		1
59	N/A	501240201000R	BASE, LE1709	For VSCN		1
60	N/A	501120101200R	LENS, LE1709	For VSCN		1
61	N/A	501030201900R	BUTTON,FUNCTION KEY, LE1709	For VSCN		1
62	C-00006088	501020203000R	COVER,HINGE, LE1709	For VSCN		2
63	N/A	501020202900R	COVER,BACK, LE1709	For VSCN		1
64	N/A	501010202700R	BEZEL,FRONT(SILVER),VA702, LE1709	For VSCN		1
65	A-00005255	453070800170R	PWRCORD 10A/250V BLK 6FT CHINA.RVV 3Gx0.	For VSCN		1
66	CB-00005254	453010100100R	CABLE,D-SUB 15P MALE 6FT BLACK/BLUE,SZ40	For VSCN		1

Item	ViewSonic P/N	Ref. P/N	Description	Location	Universal number#	Q'ty
67	CB-00005259	430303000140R	HRN LVDS FFC 30P 234mm,RoHSACCX30234KU28	For VSCN		1
68	CB-00005260	430300800320R	HRN ASS'Y 4x2P 189mm UL2651#28SZ504479B,	For VSCN		1
69	CB-00005261	430300100210R	HRN ASS'Y 1P 137mm BLACK,UL100 7 #20,RoHS	For VSCN		1

BOM LIST (VA721-3)

ViewSonic Model Number: VS1078

Rev: 1b

Serial No. Prefix: Q7P

Item	ViewSonic P/N	Ref. P/N	Description	Location	Universal number#	Q'ty
1	CB-00005254	453010100100R	CABLE,D-SUB 15P MALE 6FT BLACK/BLUE,SZ40	For VSCN & VSA		1
2	A-00005255	453070800170R	PWRCORD 10A/250V BLK 6FT CHINA,RVV 3Gx0.	For VSCN		1
3	A-00006679	453070800250R	PWR CORD 10A/125V BLK 6FT UL/CSA,SVT 18x	For VSA		1
4	N/A	506250005120R	LBL.AGENCY(VA721), LE1709	For VSCN & VSA		1
5	N/A	506440002300R	LABEL,BLANK,76.2x76.2mm,LE1709(UPC)	For VSCN & VSA		1
6	N/A	506440002400R	LABEL,BLANK,50x25mm,LE1709(S/N)	For VSCN & VSA		1
7	N/A	506390000400R	LABEL,OPENING STAND, LE1709	For VSCN & VSA		1
8	N/A	506390000500R	LABEL,QC-PASS, LE1709	For VSCN		1
9	N/A	506390000600R	LABEL,HI-POT PASS, LE1709	For VSCN & VSA		1
10	P-00005253	506040005510R	CUSHION,EPS-R, LE1709	For VSCN & VSA		1
11	P-00005257	506040005500R	CUSHION,EPS-L, LE1709	For VSCN & VSA		1
12	P-00005289	506020006820R	CARTON,VA721, LE1709	For VSCN & VSA		1
13	P-00005272	506120300400R	BAG,PE+EPE,L590xW480xT0.6mm(PRINTED)LE19	For VSCN & VSA		1
14	N/A	506380001800R	TAPE,WRAPPING TYPE,48mmx50M ROHS LE1915	For VSCN & VSA		0.004
15	N/A	506431000300R	FILM,PE 500mmx900M ROHS	For VSCN & VSA		0.0004
16	N/A	506039002301R	CORNER PAPER,2050x50x50xT3mm,LE1709 ROHS	For VSCN & VSA		0.05556
17	N/A	506039001200R	CORNER PAPER,820x50x50mm	For VSCN & VSA		0.05556
18	N/A	506150001310R	PALLET,1120x980x120mm,LE1709 ROHS	For VSCN & VSA		0.01389
19	N/A	506037003700R	CARDBOARD,COVER,L1120xW980xH120xT5mm,LE1	For VSCN & VSA		0.02778
20	A-00005292	703000000536R	KIT,ACCESSORY,VA721/B-INL,LE1709	For VSCN & VSA		1
21	N/A	71407276B110R	ASSY,FIAN(L,S,V7/G1&2&3),LE1709-6A0(VA721)	For VSCN & VSA		1
22	C-00006088	501020203000R	COVER,HINGE, LE1709	For VSCN & VSA		2
23	HW-00005276	502060401910R	HINGE,RIGHT, LE1709	For VSCN & VSA		1
24	HW-00005277	502060401900R	HINGE,LEFT, LE1709	For VSCN & VSA		1
25	HW-00005265	509412610500R	SCREW,B,CROSS,T.T-4*10,BLK ,ROHS	For VSCN & VSA		4
26	HW-00005266	509212610300R	SCREW,F,CROSS,T.T-4*10,Ni ROHS	For VSCN & VSA		4
27	HW-00005267	509116822300R	SCREW,P,CROSS,M5*22,Ni,ROHS	For VSCN & VSA		4
28	C-00005291	714030002420R	ASSY,BEZEL(S),VA721,LE1709	For VSCN & VSA		1
29	N/A	501010202720R	BEZEL,FRONT(SILVER),VA721,LE1709	For VSCN & VSA		1
30	N/A	501030201900R	BUTTON,FUNCTION KEY, LE1709	For VSCN & VSA		1
31	N/A	501120101200R	LENS, LE1709	For VSCN & VSA		1
32	N/A	506102000400R	LOGO PLATE,VIEWSONIC, LE1709(THREE BIRDS	For VSCN & VSA		1
33	N/A	506102000300R	LOGO PLATE,VIEWSONIC, LE1709	For VSCN & VSA		1
34	C-00005264	714050002400R	ASSY,BACK COVER, LE1709	For VSCN & VSA		1
35	N/A	501020202900R	COVER,BACK, LE1709	For VSCN & VSA		1
36	N/A	502080300300R	SUPPORT,VESA, LE1709 ROHS	For VSCN & VSA		1
37	N/A	503010001700R	RUBBER,SPACER,L25xW10xT4.0mm,LE1709	For VSCN & VSA		1
38	N/A	506102000500R	LOGO PLATE,VIEWSONIC, LE1709(ELLIPSE)	For VSCN & VSA		1
39	C-00005262	714020002400R	ASSY,BASE, LE1709	For VSCN & VSA		1
40	N/A	501240201000R	BASE, LE1709	For VSCN & VSA		1
41	N/A	502170300400R	PLATE,BASE,LE1709	For VSCN & VSA		1
42	N/A	503020002600R	RUBBER,FOOT,OD14.1xT2.5mm,3M, LE1708 ROH	For VSCN & VSA		4
43	N/A	71408276B100R	ASSY,PANEL(V7/G1&2&3),LE1709-6A0	For VSCN & VSA		1
44	E-00008006	631102071910R	LCD PANEL 17" MT170EN01-V7-G1,AM17000057	For VSCN & VSA		1
45	E-00008007	631102071920R	LCD PANEL 17" MT170EN01-V7-G2,AM17000057	For VSCN & VSA		1
46	E-00008008	631102071930R	LCD PANEL 17" MT170EN01-V7-G3,AM17000057	For VSCN & VSA		1
47	CB-00005259	430303000140R	HRN LVDS FFC 30P 234mm,RoHSACX30234KU28	For VSCN & VSA		1
48	B-00005278	790411500000R	PCBA,KEYPAD BOARD, LE1709 ROHS	For VSCN & VSA		1
49	CB-00005260	430300800320R	HRN ASS'Y 4x2P 189mm UL2651#28SZ504479B,	For VSCN & VSA		1
50	B-00005279	790411400600R	PCBA,PWR&INV./B, LE1709-6A0 ROHS	For VSCN & VSA		1
51	B-00008066	790411300630R	PCBA,IF BOARD(V7), LE1709- 6A0 ROHS	For VSCN & VSA		1
52	CB-00005261	430300100210R	HRN ASS'Y 1P 137mm BLACK,UL100 7 #20,RoH	For VSCN & VSA		1
53	N/A	506381000700R	TAPE,ACE,45mmx30M(PC=10x45mm),LE1709 ROH	For VSCN & VSA		0.001
54	N/A	502090301300R	CHASSIS, LE1709	For VSCN & VSA		1
55	N/A	502020300700R	BRACKET,LEFT, LE1709	For VSCN & VSA		1
56	N/A	502020300710R	BRACKET,RIGHT, LE1709	For VSCN & VSA		1
57	HW-00005269	509146305300R	SCREW,PW,CROSS,W/WAS,M3*5,NI	For VSCN & VSA		9
58	HW-00005270	509000000700R	BOLT,#4-40x11.8,Ni FOR D-SUB/DVI CONN.RO	For VSCN & VSA		2
59	HW-00005271	509016304102R	SCREW,I,CROSS,M3*4,Zw,ROHS	For VSCN & VSA		4
60	N/A	511100001500R	CLIP,WIRE,CH-01P(PG), LE1709	For VSCN & VSA		1
61	N/A	505040202000R	INSULATOR,MYLAR,L79.7xW62.7mm,CHASSIS,	For VSCN & VSA		1
62	HW-00005271	509016304102R	SCREW,I,CROSS,M3*4,Zw,ROHS	For VSCN & VSA		1
63	N/A	506440002600R	LABEL,BLANK,210x65mm,LE1709(PALLET)	For VSCN & VSA		0.02778
64	N/A	506380002100R	TAPE,WRAPPING TYPE(VIEWSONIC),50mmx75M,	For VSCN & VSA		0.00513
65	N/A	506390210100R	LABEL,CARTON(8ms), LE1709,L89xW58mm	For VSA		1
66	N/A	506390210110R	LABEL,CARTON(8ms),PRC, LE1709	For VSCN		1
67	N/A	506091000500R	LABEL,WARRANTY, LE1709	For VSCN		1
68	N/A	506092001400R	CARD,WARRANTY, LE1709	For VSCN		1
69	P-00005273	506120004500R	BAG,PLASTIC,L690xW(455+145)xT0.05mm,	For VSCN		1
70	N/A	506030200200R	CARD,AFTER SERVICE, LE1709,L130xW80	For VSCN		1
71	N/A	506390500100R	LABEL,ENERGY STAR, LE1709	For VSCN & VSA		1

BOM LIST (VA721b-3)

ViewSonic Model Number: VS10781

Rev: 1b

Serial No. Prefix: Q84

Item	ViewSonic P/N	Ref. P/N	Description	Location	Universal number#	Q'ty
1	CB-00005254	453010100100R	CABLE,D-SUB 15P MALE 6FT BLACK/BLUE,SZ40	For VSCN		1
2	A-00005255	453070800170R	PWRCORD 10A/250V BLK 6FT CHINA.RVV 3Gx0.	For VSCN		1
3	N/A	506250005130R	LBL.AGENCY(VA721B), LE1709	For VSCN		1
4	N/A	506440002300R	LABEL,BLANK,76.2x76.2mm,LE1709(UPC)	For VSCN		1
5	N/A	506440002400R	LABEL,BLANK,50x25mm,LE1709(S/N)	For VSCN		1
6	N/A	506390000400R	LABEL,OPENING STAND, LE1709	For VSCN		1
7	N/A	506390000500R	LABEL,QC-PASS, LE1709	For VSCN		1
8	N/A	506390000600R	LABEL,HI-POT PASS, LE1709	For VSCN		1
9	P-00005253	506040005510R	CUSHION,EPS-R, LE1709	For VSCN		1
10	P-00005257	506040005500R	CUSHION,EPS-L, LE1709	For VSCN		1
11	P-00005288	506020006830R	CARTON,VA721B, LE1709	For VSCN		1
12	P-00005272	506120300400R	BAG,PE+EPE,L590xW480xT0.6mm(PRINTED)LE19	For VSCN		1
13	N/A	506380001800R	TAPE,WRAPPING TYPE,48mmx50M ROHS LE1915	For VSCN		0.004
14	N/A	506431000300R	FILM,PE 500mmx900M ROHS	For VSCN		0.0004
15	N/A	506039002301R	CORNER PAPER,2050x50x50xT3mm,LE1709 ROHS	For VSCN		0.05556
16	N/A	506039001200R	CORNER PAPER,820x50x50mm	For VSCN		0.05556
17	N/A	506150001310R	PALLET,1120x980x120mm,LE1709 ROHS	For VSCN		0.01389
18	N/A	506037003700R	CARDBOARD,COVER,L1120xW980xH120xT5mm,LE1	For VSCN		0.02778
19	A-00005292	703000000536R	KIT,ACCESSORY,VA721/B-INL,LE1709	For VSCN		1
20	N/A	71407276B111R	ASSY,FIANL(G,V7/G1&2&3),LE1709-6A0(VA721B)	For VSCN		1
21	C-00006088	501020203000R	COVER,HINGE, LE1709	For VSCN		2
22	HW-00005276	502060401910R	HINGE,RIGHT, LE1709	For VSCN		1
23	HW-00005277	502060401900R	HINGE,LEFT, LE1709	For VSCN		1
24	HW-00005265	509412610500R	SCREW,B,CROSS,T.T-4*10,BLK ,ROHS	For VSCN		4
25	HW-00005266	509212610300R	SCREW,F,CROSS,T.T-4*10,Ni ROHS	For VSCN		4
26	HW-00005267	509116822300R	SCREW,P,CROSS,M5*22,Ni,ROHS	For VSCN		4
27	C-00005290	714030002430R	ASSY,BEZEL(G),VA721B,LE1709	For VSCN		1
28	N/A	501010202730R	BEZEL,FRONT(GRAY),VA721B,LE1709	For VSCN		1
29	N/A	501030201900R	BUTTON,FUNCTION KEY, LE1709	For VSCN		1
30	N/A	501120101200R	LENS, LE1709	For VSCN		1
31	N/A	506102000400R	LOGO PLATE,VIEWSONIC, LE1709(THREE BIRDS	For VSCN		1
32	N/A	506102000300R	LOGO PLATE,VIEWSONIC, LE1709	For VSCN		1
33	C-00005264	714050002400R	ASSY,BACK COVER, LE1709	For VSCN		1
34	N/A	501020202900R	COVER,BACK, LE1709	For VSCN		1
35	N/A	502080300300R	SUPPORT,VESA, LE1709 ROHS	For VSCN		1
36	N/A	503010001700R	RUBBER,SPACER,L25xW10xT4.0mm,LE1709	For VSCN		1
37	N/A	506102000500R	LOGO PLATE,VIEWSONIC, LE1709(ELLIPSE)	For VSCN		1
38	C-00005262	714020002400R	ASSY,BASE, LE1709	For VSCN		1
39	N/A	501240201000R	BASE, LE1709	For VSCN		1
40	N/A	502170300400R	PLATE,BASE, LE1709	For VSCN		1
41	N/A	503020002600R	RUBBER,FOOT,OD14.1xT2.5mm,3M, LE1708 ROH	For VSCN		4
42	N/A	71408276B100R	ASSY,PANEL(V7/G1&2&3),LE1709-6A0	For VSCN		1
43	E-00008006	631102071910R	LCD PANEL 17" MT170EN01-V7-G1,AM17000057	For VSCN		1
44	E-00008007	631102071920R	LCD PANEL 17" MT170EN01-V7-G2,AM17000057	For VSCN		1
45	E-00008008	631102071930R	LCD PANEL 17" MT170EN01-V7-G3,AM17000057	For VSCN		1
46	CB-00005259	430303000140R	HRN LVDS FFC 30P 234mm,RoHSACCX30234KU28	For VSCN		1
47	B-00005278	790411500000R	PCBA,KEYPAD BOARD, LE1709 ROHS	For VSCN		1
48	CB-00005260	430300800320R	HRN ASS'Y 4x2P 189mm UL2651#28SZ504479B,	For VSCN		1
49	B-00005279	790411400600R	PCBA,PWR&INV./B, LE1709-6A0 ROHS	For VSCN		1
50	B-00008066	790411300630R	PCBA,IF BOARD(V7), LE1709- 6A0 ROHS	For VSCN		1
51	CB-00005261	430300100210R	HRN ASS'Y 1P 137mm BLACK,UL100 7 #20,RoHS	For VSCN		1
52	N/A	506381000700R	TAPE,ACE,45mmx30M(PC=10x45mm),LE1709 ROHS	For VSCN		0.001
53	N/A	502090301300R	CHASSIS, LE1709	For VSCN		1
54	N/A	502020300700R	BRACKET,LEFT, LE1709	For VSCN		1
55	N/A	502020300710R	BRACKET,RIGHT, LE1709	For VSCN		1
56	HW-00005269	509146305300R	SCREW,PW,CROSS,W/WAS,M3*5,NI	For VSCN		9
57	HW-00005270	509000000700R	BOLT,#4-40x11.8,NI FOR D-SUB/DVI CONN.RO	For VSCN		2
58	HW-00005271	509016304102R	SCREW,I,CROSS,M3*4,Zw,ROHS	For VSCN		4
59	N/A	511100001500R	CLIP,WIRE,CH-01P(PG), LE1709	For VSCN		1
60	N/A	505040202000R	INSULATOR,MYLAR,L79.7xW62.7mm,CHASSIS,	For VSCN		1
61	HW-00005271	509016304102R	SCREW,I,CROSS,M3*4,Zw,ROHS	For VSCN		1
62	N/A	506440002600R	LABEL,BLANK,210x65mm,LE1709(PALLET)	For VSCN		0.02778
63	N/A	506380002100R	TAPE,WRAPPING TYPE(VIEWSONIC),50mmx75M,	For VSCN		0.00513
64	N/A	506390210110R	LABEL,CARTON(8ms),PRC, LE1709	For VSCN		1
65	N/A	506091000500R	LABEL,WARRANTY, LE1709	For VSCN		1
66	N/A	506092001400R	CARD,WARRANTY, LE1709	For VSCN		1
67	P-00005273	506120004500R	BAG,PLASTIC,L690xW(455+145)xT0.05mm,	For VSCN		1
68	N/A	506030200200R	CARD,AFTER SERVICE, LE1709,L130xW80	For VSCN		1
69	N/A	506390500100R	LABEL,ENERGY STAR, LE1709	For VSCN		1

8. Exploded Diagram and Exploded Parts List

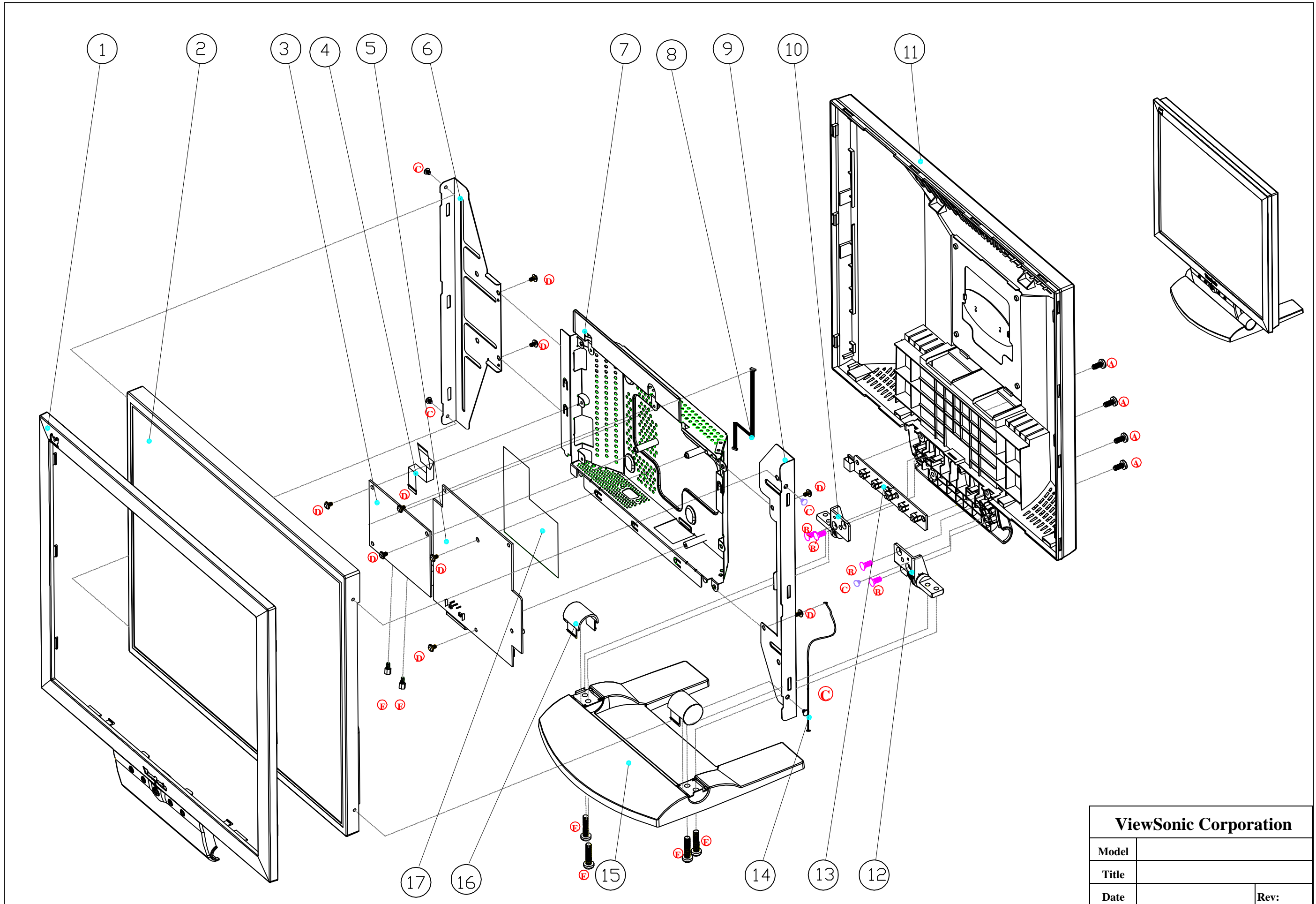

EXPLODED PARTS LIST (VA702-2 / VA721-3 / VA721b-3)

ViewSonic Model Number: VS10781

Rev: 1a

Serial No. Prefix: Q4F / Q7P / Q84

Item	ViewSonic P/N	Ref. P/N	Description	Q'ty
1	C-00003154	714030002400	ASSY,BAXEL(S)/BEZEL(G),LE1709	1
2	E-00003048	631102070270	LCD Panel 17"MT170EN01-V1(Innolux)	1
3	B-00003041	790411300600	PCBA IF BOARD, LE1709-6A0	1
4	CB-00003155	430303000140	HRN LVDS FFC 30P 234mm,ACCX3023KU28MY	1
5	B-00003043	790411400600	PCBA PWR&INV./B LE1709-6A0	1
6	HW-00003156	502020300700	BRACKET, LEFT, LE1709	1
7	B-00003172	502090301300	CHASSIS, LE1709	1
8	CB-00003157	430300800320	HRN ASS'Y 4x2P 189mm	1
9	HW-00003158	502020300710	BRACKET, RIGHT, LE1709	1
10	HW-00003159	502060401900	HINGE, LEFT, LE1709	1
11	C-00003160	714050002400	Assy,Back Cover, LE1709	1
12	HW-00003161	502060401910	HINGE, RIGHT, LE1709	1
13	B-00003042	790411500000	PCBA, Keypad board, LE1709	1
14	CB-00003162	430300100190	HRN ASS'Y 1P 157mm BLACK, UL1007#20	1
15	C-00003163	714020002400	Assy, Base, LE1709	1
16	C-00003164	501020203000	COVER, HINGE, LE1709	2
17	M-00003165	505040202000	INSULATOR, MYLAR, CHASSIS, LE1708	1

Packing for Shipping

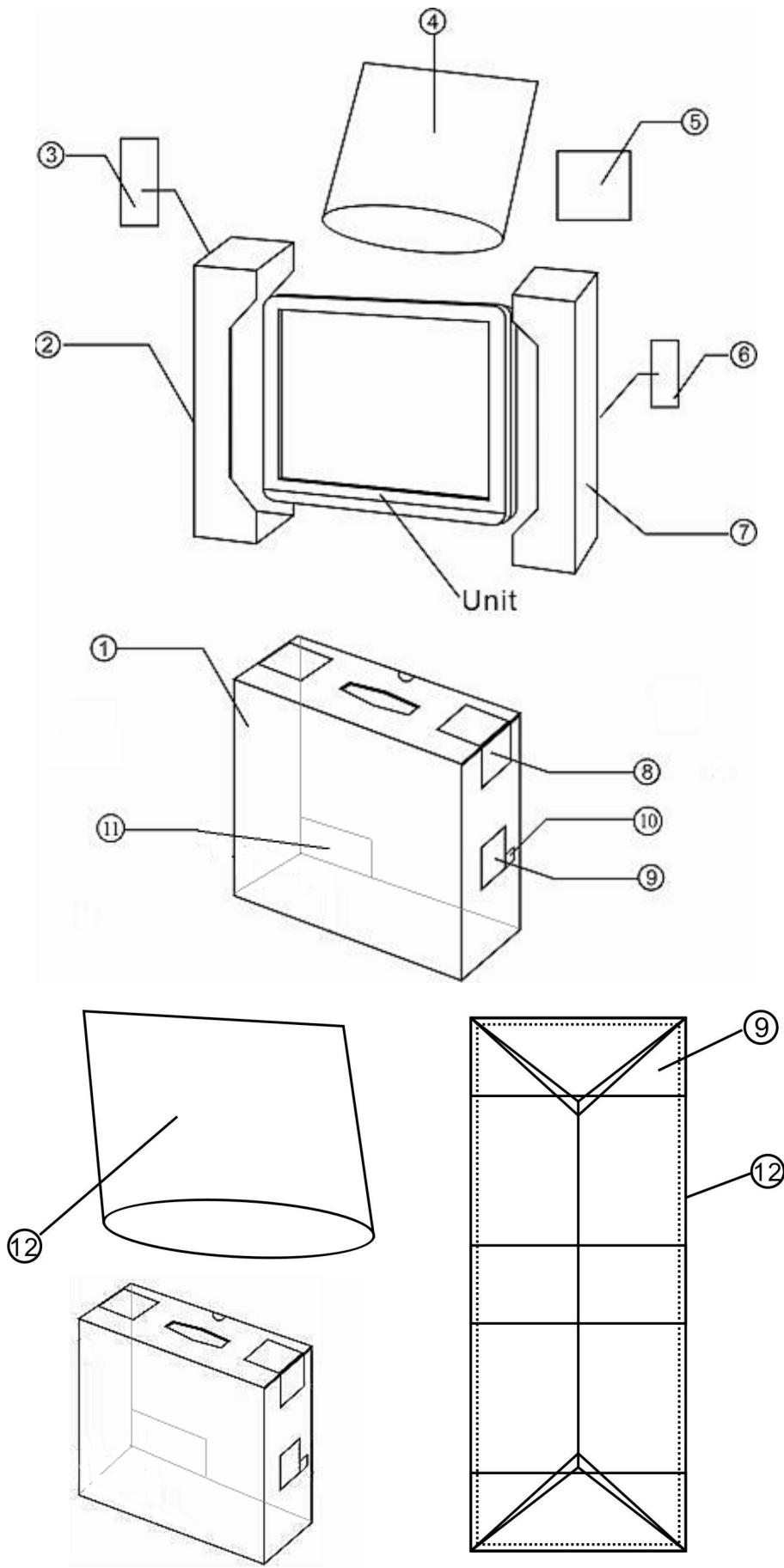

PACKING PARTS LIST(VA702-2)

ViewSonic Model Number: VS10781-2

Rev: 1a

Item	ViewSonic P/N	Ref. P/N	Location	Q'ty
1	N/A	506020006800	Carton LE1709	1
	P-00003056	506020006810		
2	N/A	50604005500	Cushion,Left,LE1709	1
3	A-00003676	453070800170	PWRCORD 10A/250V BLK 6FT CHINA	1
4	P-00003943	506120300400	BAG,PE+EPE,L590xW480xT0.6mm (PRINTED)LE1	1
5	N/A		Accessory Assm&After service card	1set
5.1	N/A	703000000505/6	Accessory Assm	1
	N/A	703000000515/6		
5.2	N/A	506030200200	CARD,AFTER SERVICE, LE1709.L130xW80	1
6			CARD,WARRANTY Assm	1set
6.1	N/A	506092001400	CARD,WARRANTY, LE1709	1
6.2	N/A	506440003000	LABEL,BLANK,35x8mm,LE1709	2
7	CB-00004328	453010100070	CABLE,D-SUB 15P MALE 6FT BLACK/BLUE(MINI)	1
8	P-00003052	506040005510	Cushion,right,LE1709	0.048
9	N/A	506380001800	TAPE,WRAPPING TYPE,48mmx50M LE1X04/05	1
10	N/A	506440002300	LABEL,BLANK,76.2x76.2mm,LE1709(UPC)	1
11	N/A	506390400100R	LABEL,PRODUCT(2), LE1709	1
12	N/A	506120004500	BAG,PLASTIC,l690xW(455+145)xT0.05mm, LE1709	1
13	N/A	506091000500	LABEL,WARRANTY, LE1709	1

PACKING PARTS LIST(VA721/b-3)

ViewSonic Model Number: VS10781-3W

Rev: 1a

Item	ViewSonic P/N	Ref. P/N	Location	Q'ty
1	N/A	506020006820	Carton LE1709(VA721/b)	1
	N/A	506020006830		
2	P-00003051	506040005500	Cushion,Left,LE1709	1
3	A-00003676	453070800170	PWRCORD 10A/250V BLK 6FT CHINA	1
4	P-00003943	506120300400	BAG,PE+EPE,L590xW480xT0.6mm (PRINTED)LE1	1
5			Accessory Assm&After service card	1set
5.1	N/A	703000000526R	Accessory Assm	1
5.2	N/A	506030200200	CARD,AFTER SERVICE, LE1709.L130xW80	1
6			CARD,WARRANTY Assm	1set
6.1	N/A	506092001400	CARD,WARRANTY, LE1709	1
6.2	N/A	506440003000	LABEL,BLANK,35x8mm,LE1709	2
7	CB-00004328	453010100070	CABLE,D-SUB 15P MALE 6FT BLACK/BLUE(MINI)	1
8	P-00003052	506040005510	Cushion,right,LE1709	0.048
9	N/A	506380001800	TAPE,WRAPPING TYPE,48mmx50M LE1X04/05	1
10	N/A	506440002300	LABEL,BLANK,76.2x76.2mm,LE1709(UPC)	1
11	N/A	506500003110R	LABEL,"3" MARK(20x20mm), LE1709 (VA721/b)	1
12	N/A	506120004500	BAG,PLASTIC,l690xW(455+145)xT0.05mm, LE1709	1
13	N/A	506091000500	LABEL,WARRANTY, LE1709	1

9. Block Diagram

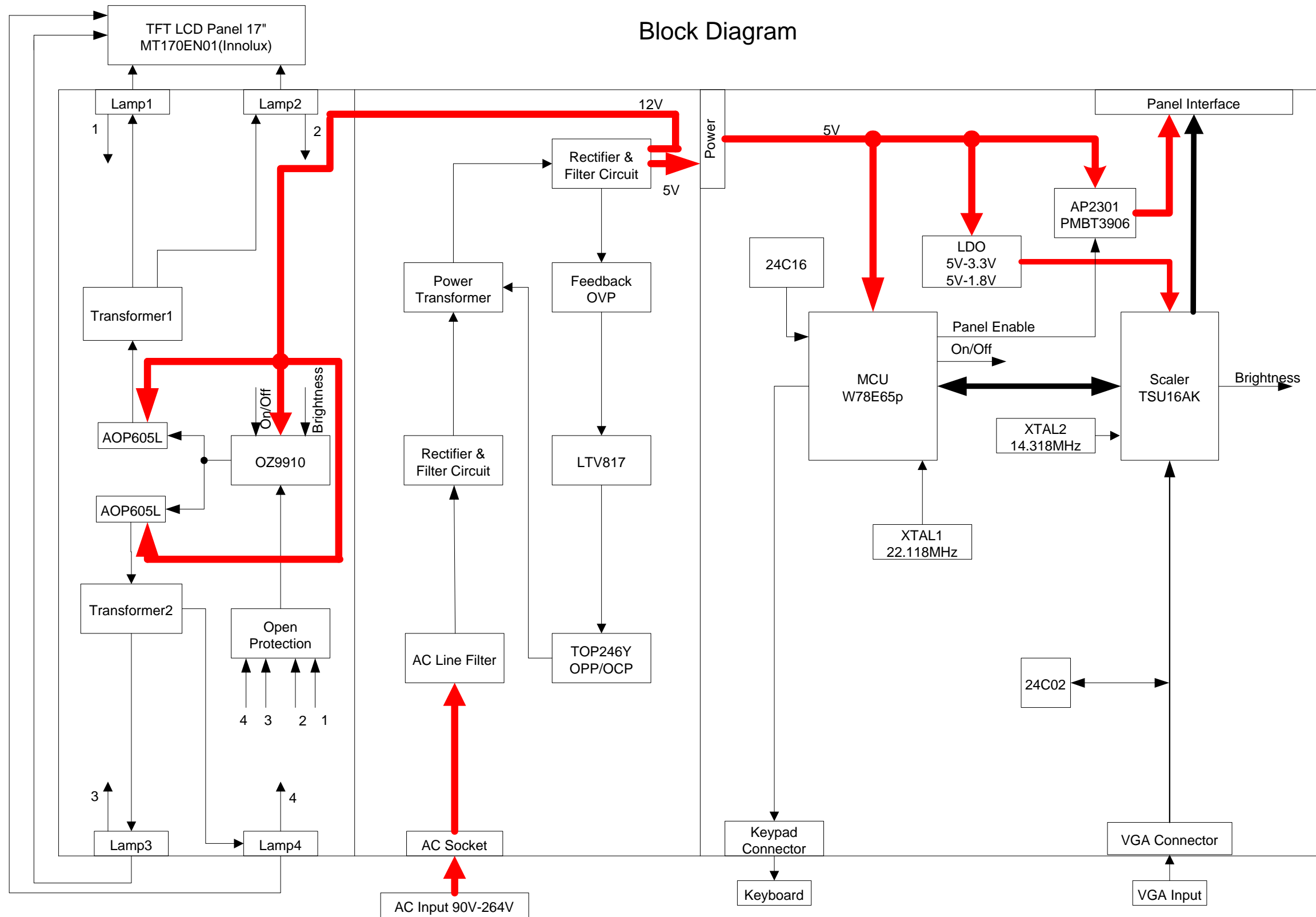

10. Schematic Diagrams

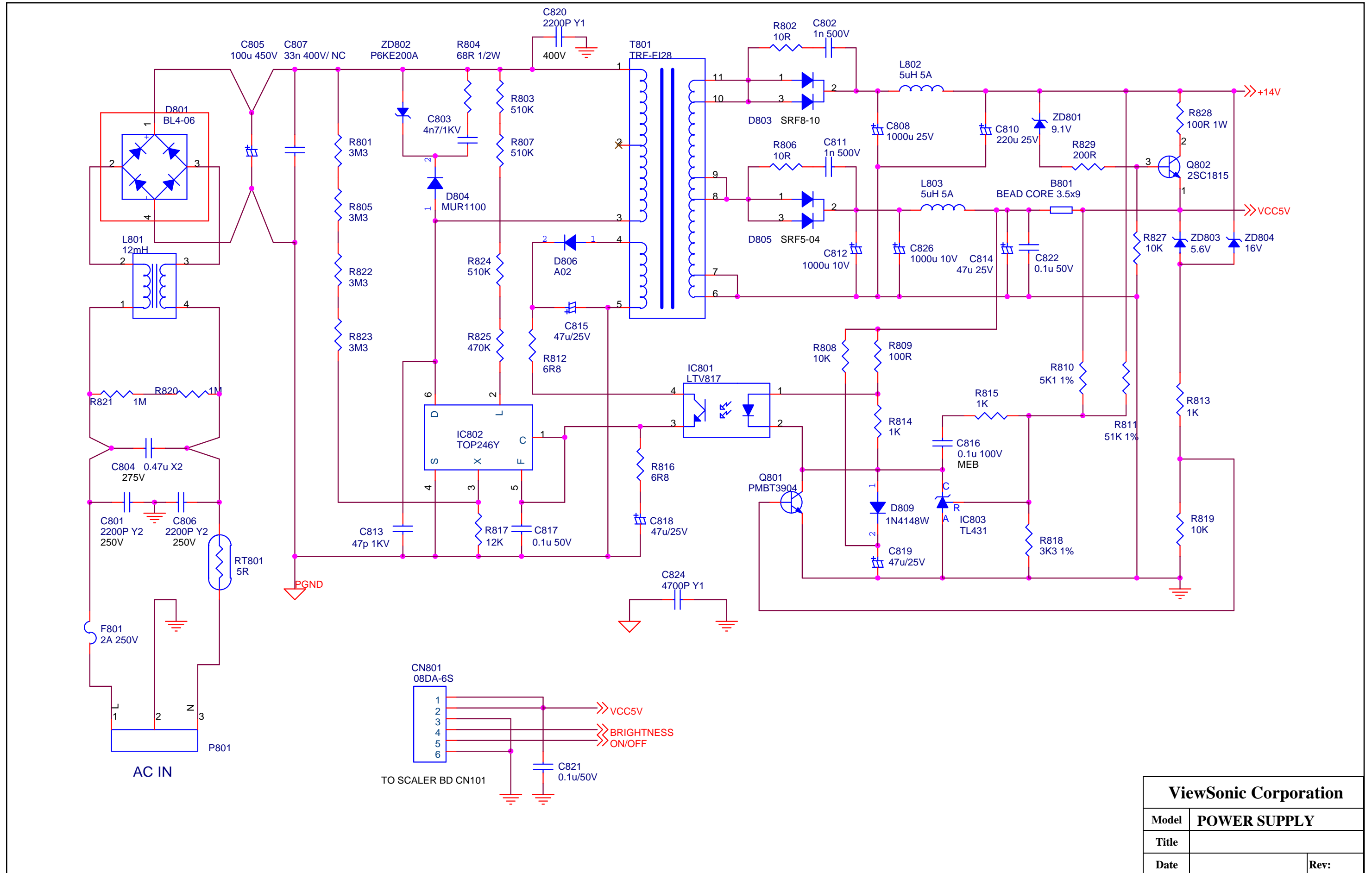

ViewSonic Corporation	
Model	POWER SUPPLY
Title	
Date	Rev:

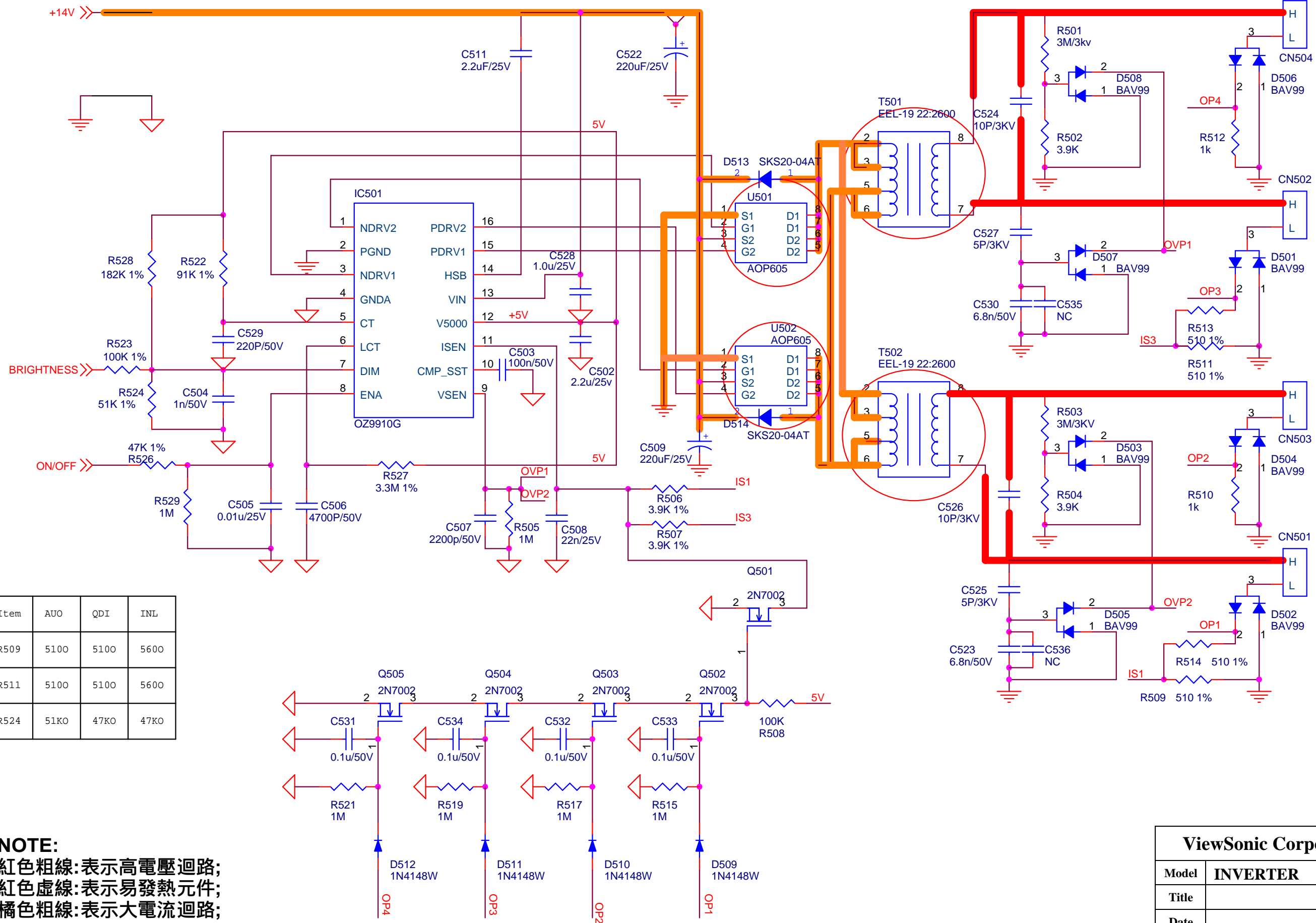

Item	AUO	QDI	INL
R509	5100	5100	5600
R511	5100	5100	5600
R524	51KO	47KO	47KO

NOTE:
 紅色粗線:表示高電壓迴路;
 紅色虛線:表示易發熱元件;
 橘色粗線:表示大電流迴路;

ViewSonic Corporation	
Model	INVERTER
Title	
Date	Rev:

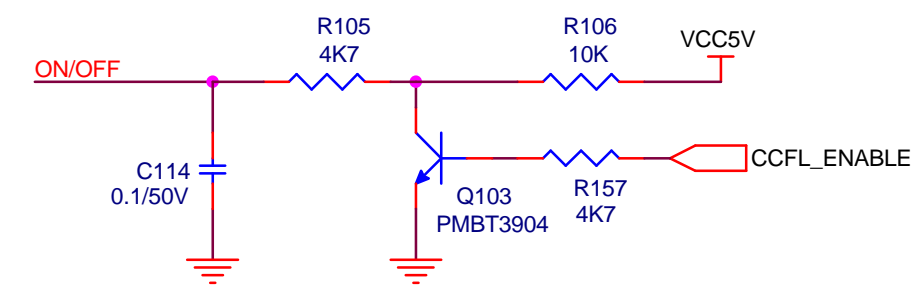
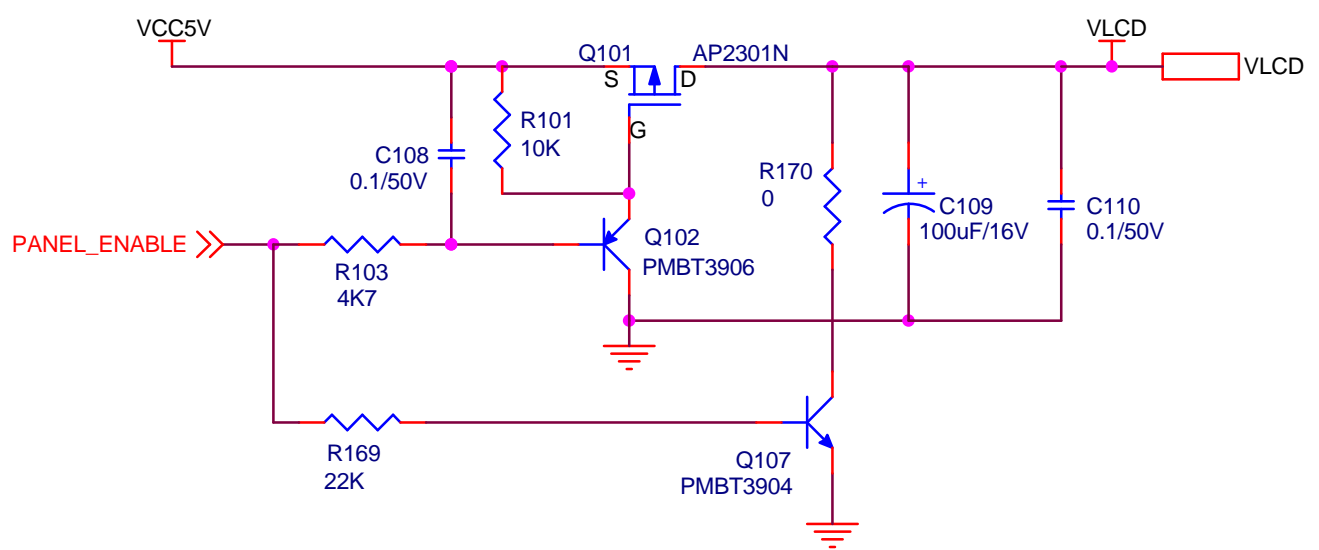
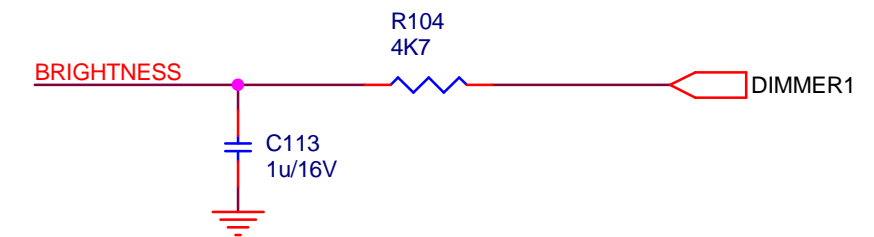
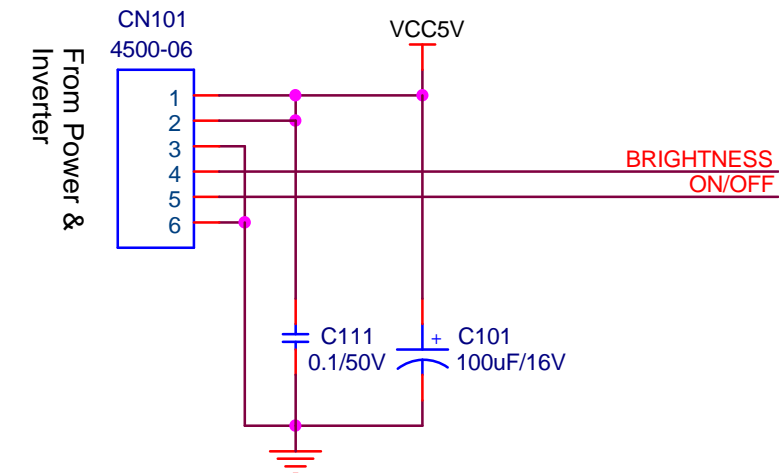
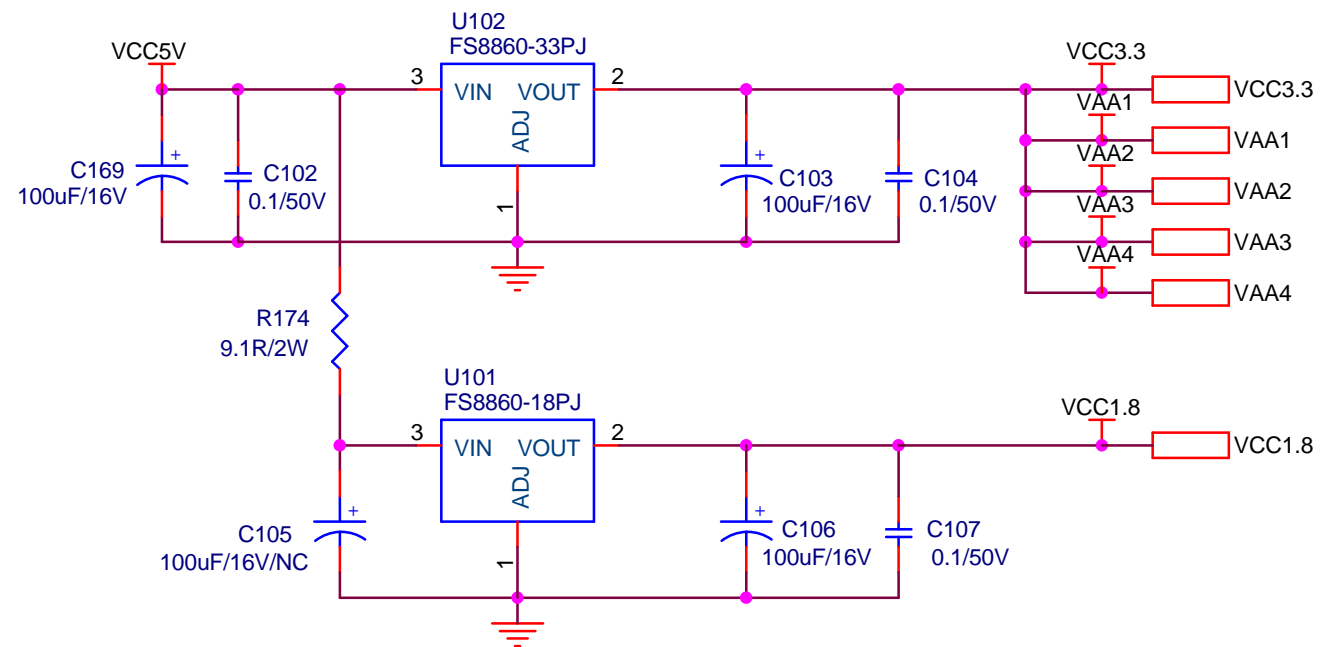

ViewSonic Corporation	
Model	DC INPUT
Title	
Date	Rev:

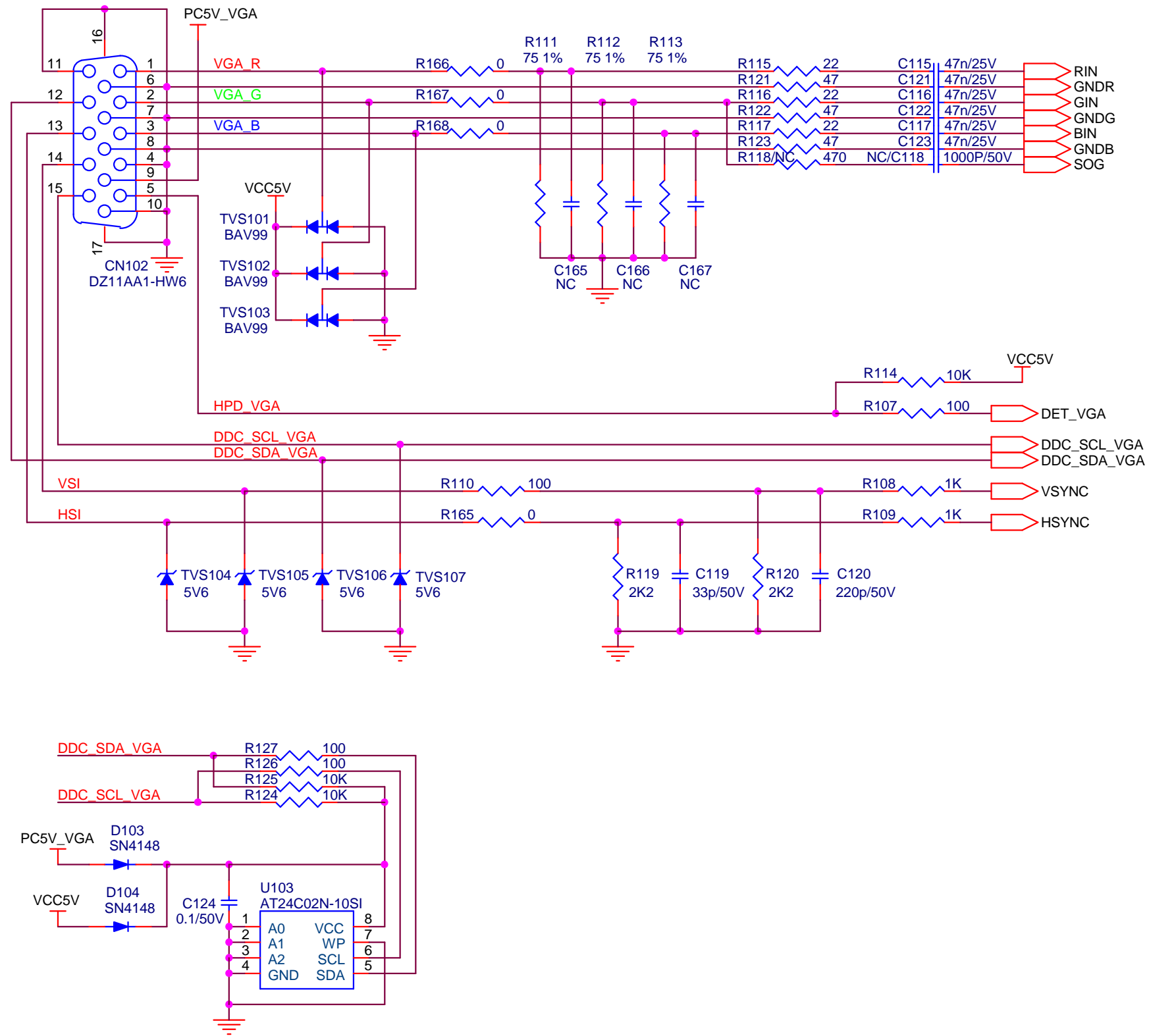

ViewSonic Corporation	
Model	VGA_INPUT
Title	
Date	Rev:

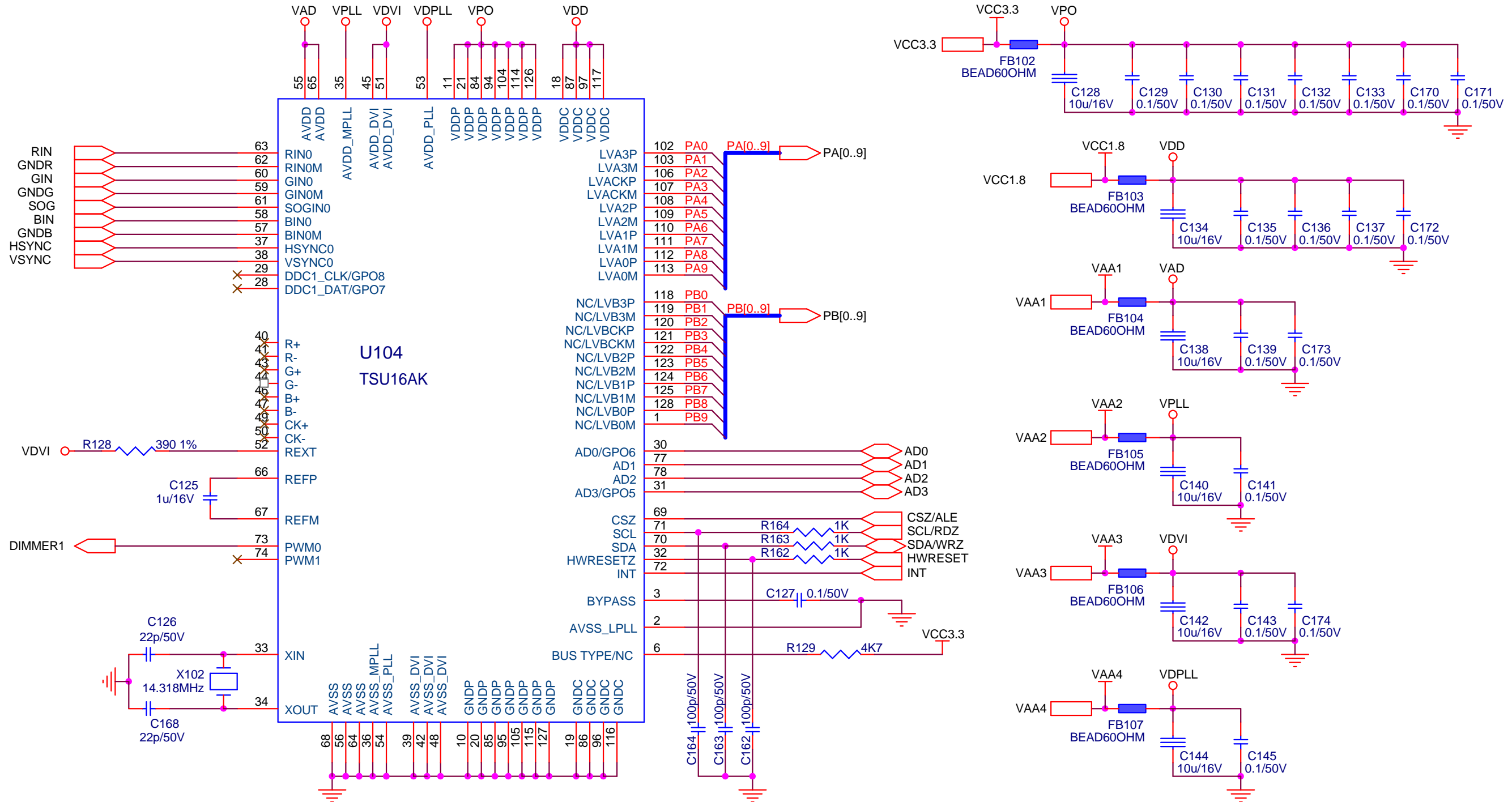

Note: U104 pin4,5,7~9,12~17,22~27,75,76,79~83,88~93,98~101 are all NC (open)

ViewSonic Corporation	
Model	SCALER
Title	
Date	Rev:

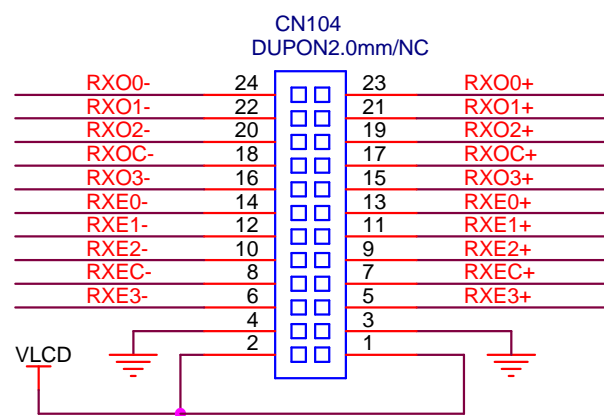
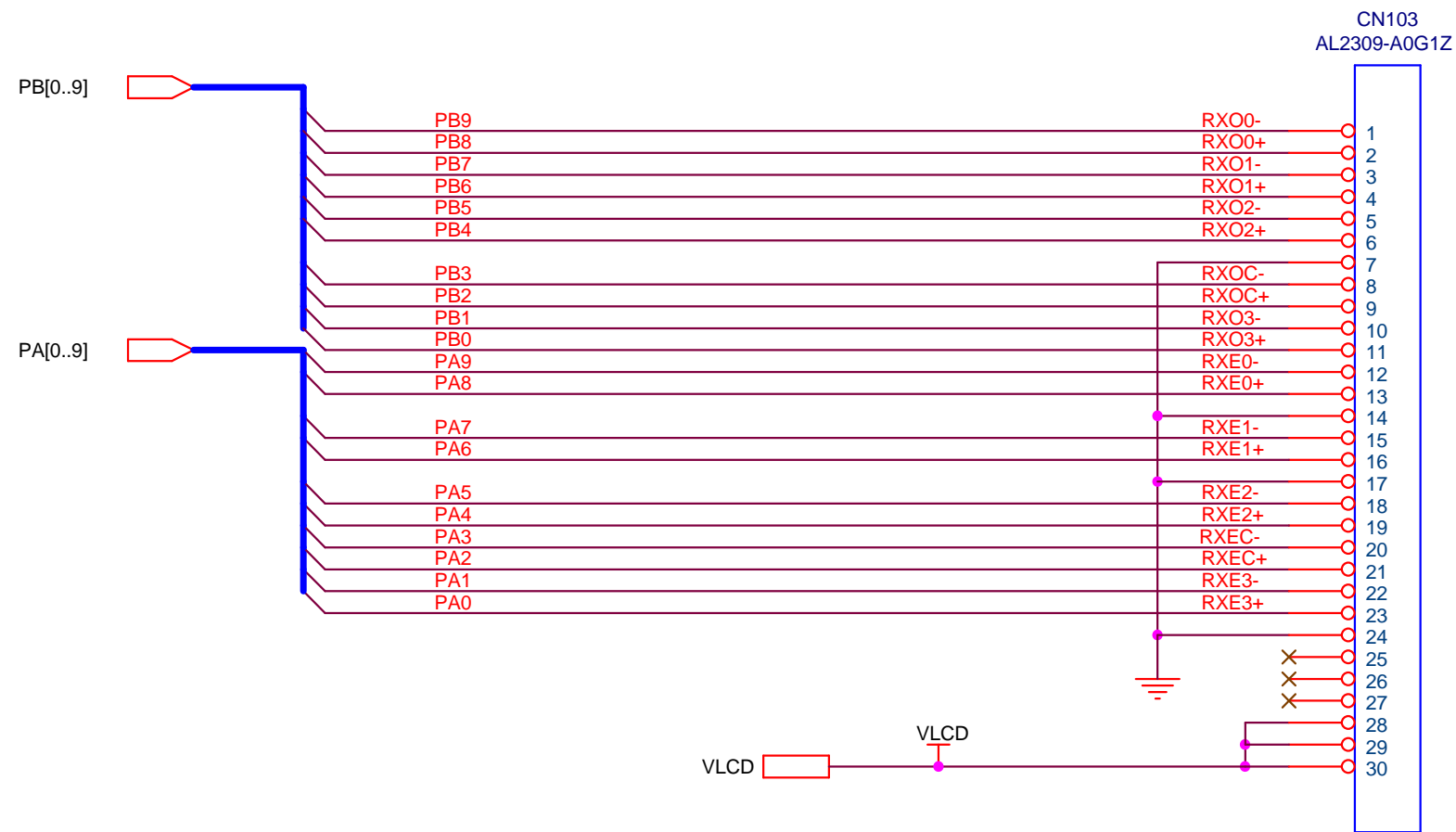

ViewSonic Corporation	
Model	PANEL INTERFACE
Title	
Date	Rev:

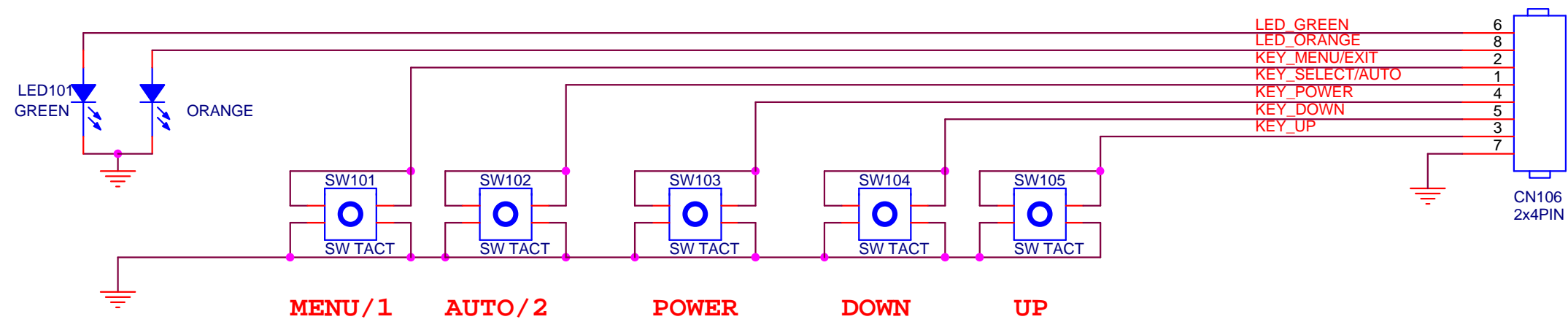

ViewSonic Corporation	
Model	KEYPAD
Title	
Date	Rev:

11. PCB Layout Diagrams

Main board Top layout

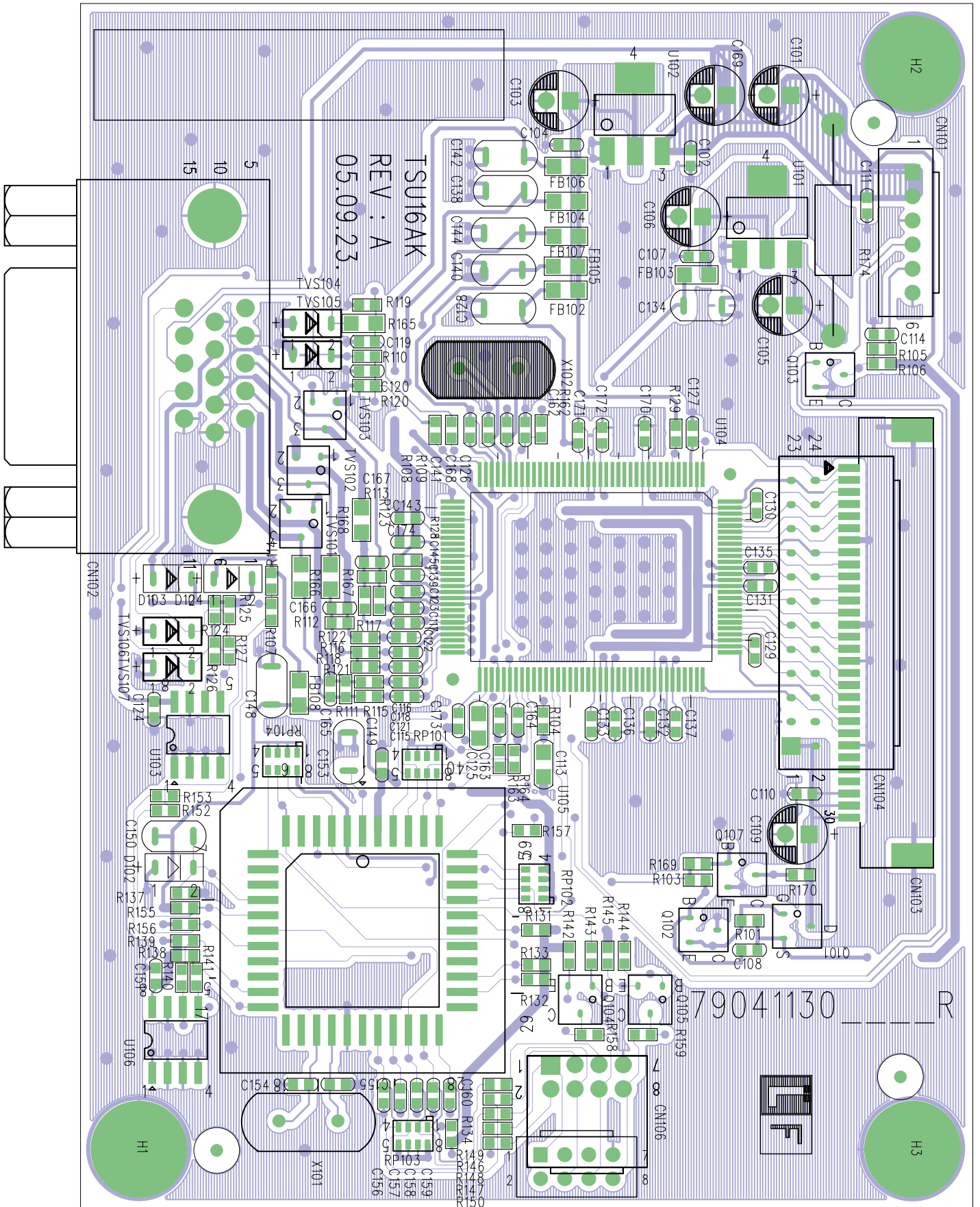

Main board bottom Layout

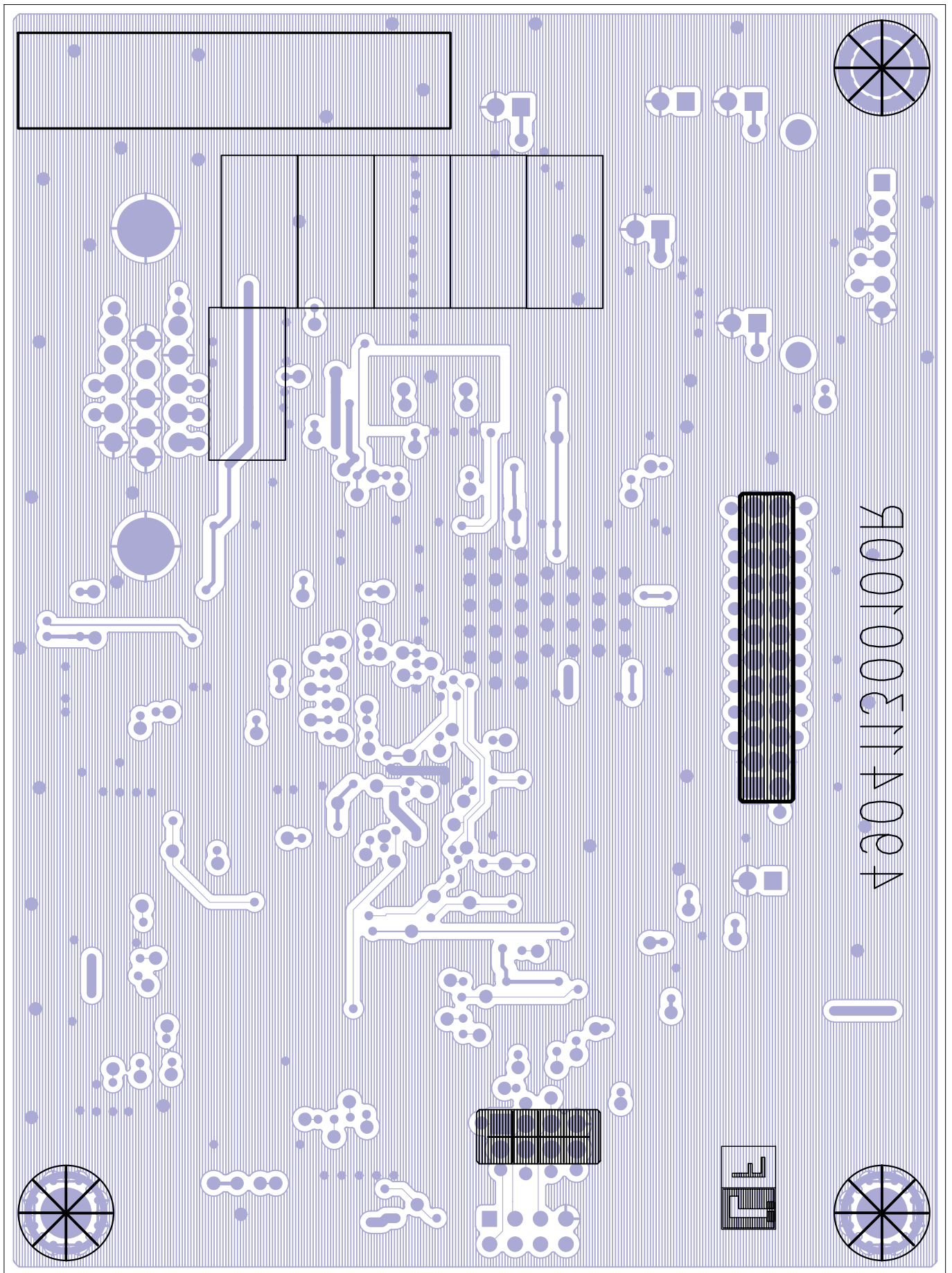

POWER board

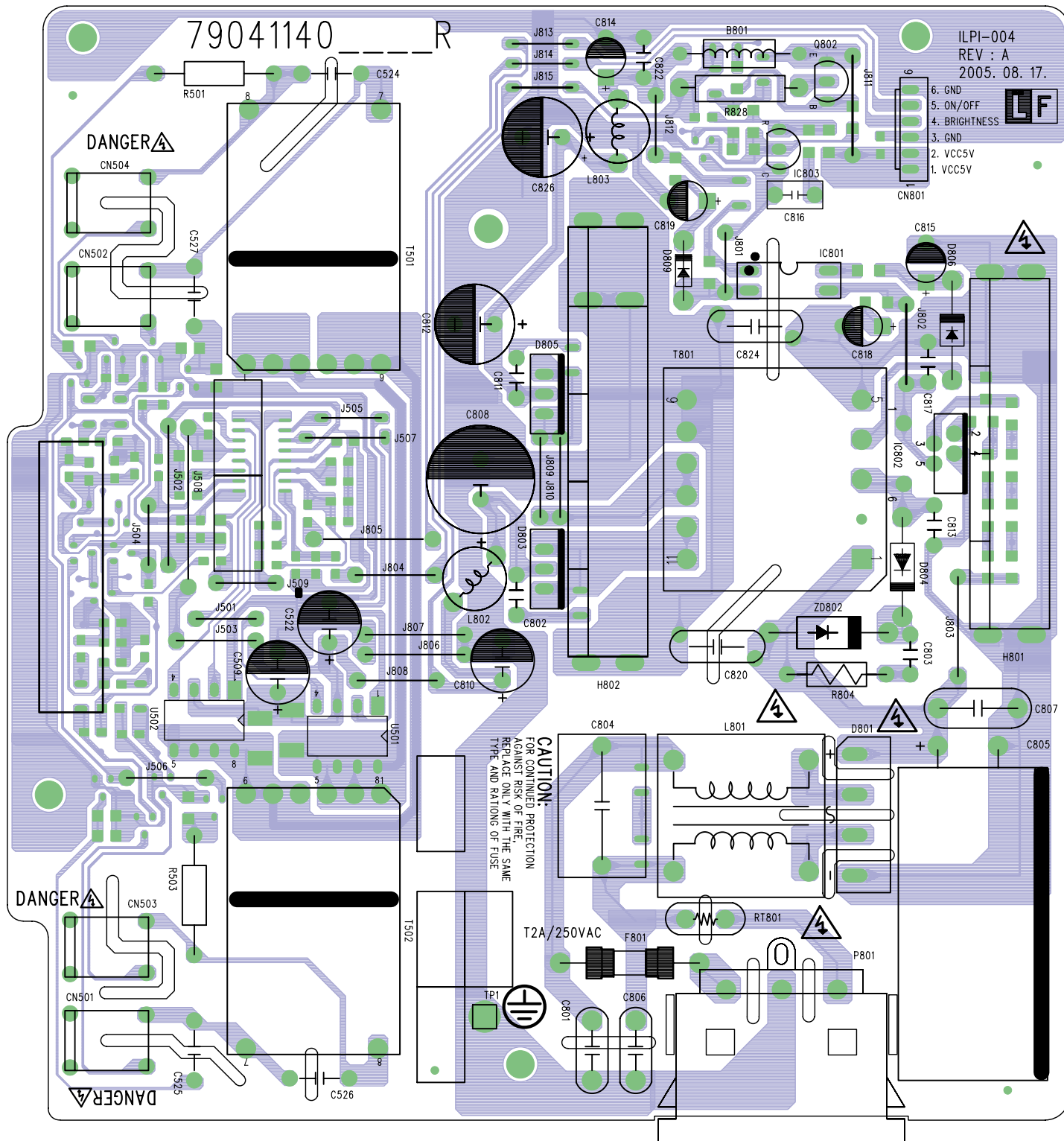

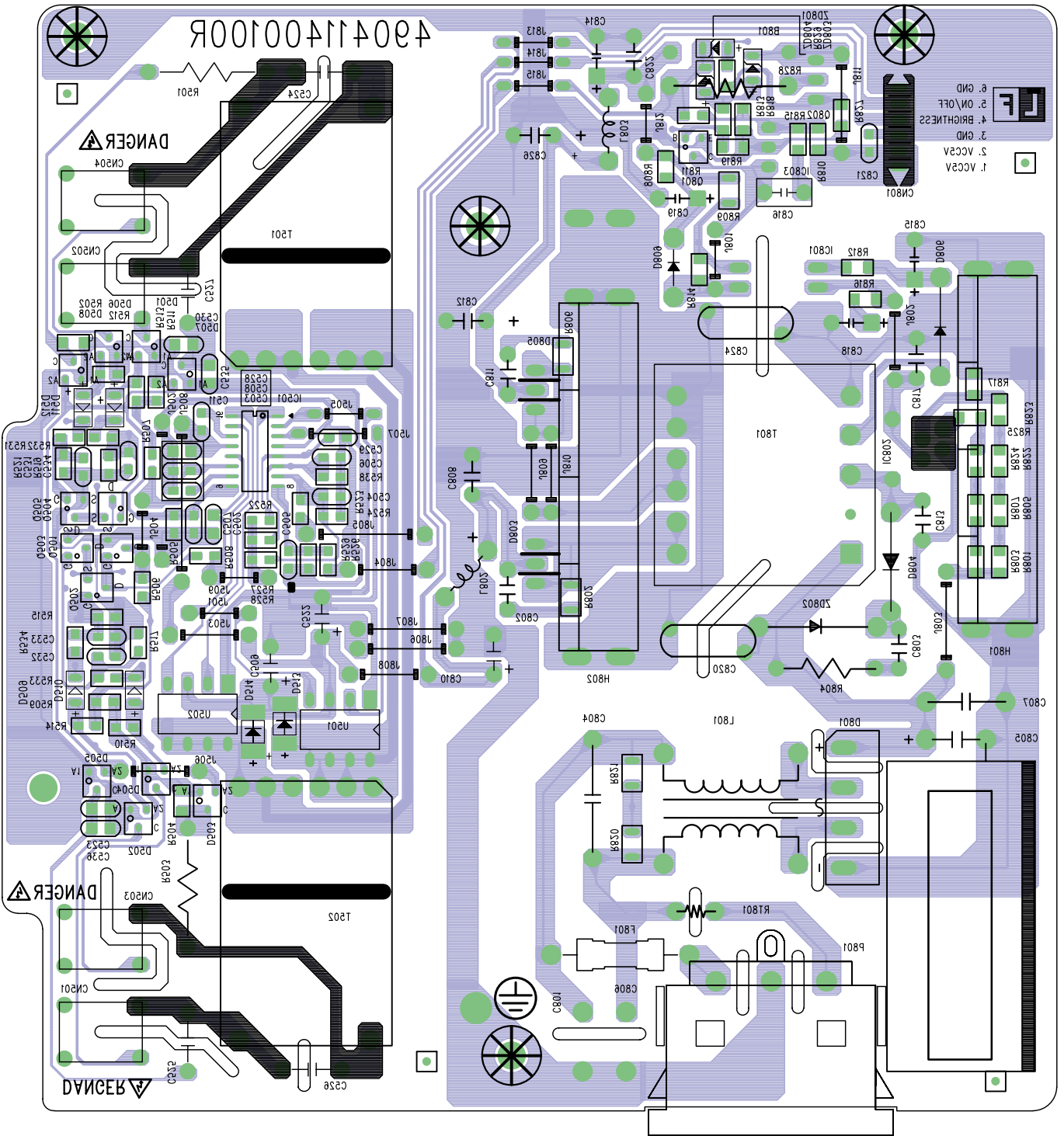

*Reader's Response**

Dear Readers:

Thank you in advance for your feedback on our Service Manual, which allows continuous improvement of our products. We would appreciate your completion of the Assessment Matrix below, for return to ViewSonic Corporation.

Assessment

A. What do you think about the content of this Service Manual?

<i>Unit</i>	<i>Excellent</i>	<i>Good</i>	<i>Fair</i>	<i>Bad</i>
1. Precautions and Safety Notices				
2. Specification				
3. Front Panel Function Control Description				
4. Circuit Description				
5. Adjustment Procedure				
6. Troubleshooting Flow Chart				
7. Recommended Spare Parts List				
8. Exploded Diagram and Exploded Parts List				
9. Block Diagrams				
10. Schematic Diagrams				
11. PCB Layout Diagrams				

B. Are you satisfied with this Service Manual?

<i>Item</i>	<i>Excellent</i>	<i>Good</i>	<i>Fair</i>	<i>Bad</i>
1. Service Manual Content				
2. Service Manual Layout				
3. The form and listing				

C. Do you have any other opinions or suggestions regarding this service manual?

Reader's basic data:

Name:		Title:	
Company:			
Add:			
Tel:		Fax:	
E-mail:			

After completing this form, please return it to ViewSonic Quality Assurance in the USA at facsimile 1-909-839-7943. You may also e-mail any suggestions to the Director, Quality Systems & Processes (marc.maupin@viewsonic.com)