

Ellis 6000

Belt Grinder



MFG. COMPANY, INC.

PARTS CATALOG

INSTALLATION & OPERATING INSTRUCTIONS

P.O. Box 930219 | Verona, WI 53593-0219 | 1-800-383-5547

MODEL 6000 BELT GRINDER P

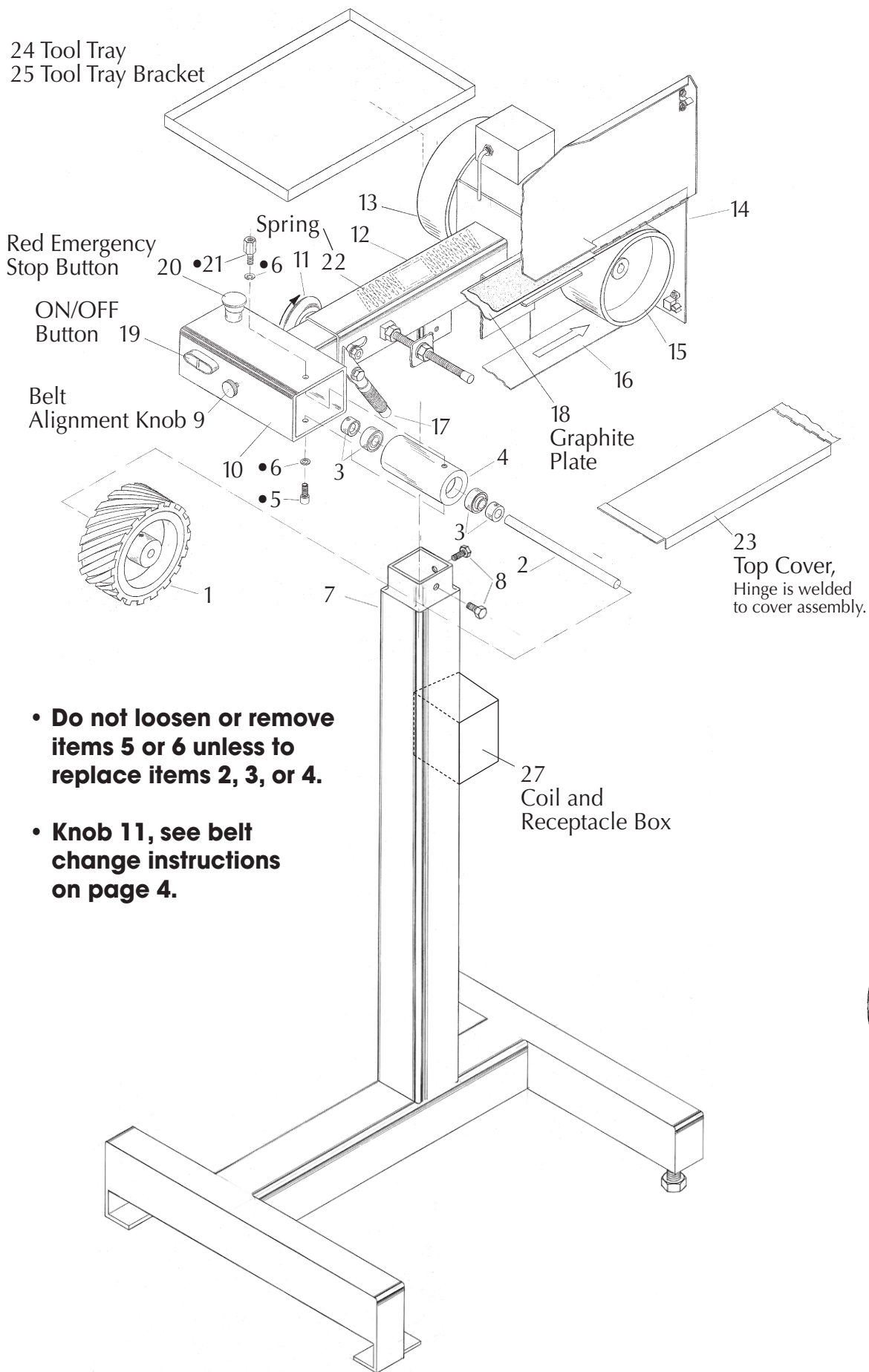

- Do not loosen or remove items 5 or 6 unless to replace items 2, 3, or 4.
- Knob 11, see belt change instructions on page 4.

ARTS LIST AND ILLUSTRATION

MODEL 6000 BELT GRINDER

ITEM No.	PART No.	DESCRIPTION
1	4655	Contact Wheel
2	7017	Spindle
3	4506	Ball Bearing
4	7016	Bearing Housing
5	4162	Sock. Hd Cap Screw, 3/8-16 x 3/4
6	4339	Lock Washer
7	7004	Stand — Welded Assy.
8	4022	Hex. Head Bolt, 3/8-16 x 3/4
9	7027	Belt Alignment Knob
10	7009	Sliding Tube — Welded Assy.
11	7026	Belt Release Handle
12	7007	Mounting Plate and Tube-Welded Assy.
13	7008	Motor Assy.

ITEM No.	PART No.	DESCRIPTION
14	7003	Cover Assy.
15	7034	Drive Pulley
16	4972	Abrasive Belts, 2½ x 60, Grits 36-220
17	7035	Belt Release Lever Assy.
18	7037	Graphite Plate
19	4807	On-Off Button
20	4809	Red Emergency Stop Button
21	7070	Adapter Bolt
22	7050	Spring
23	7051	Top Cover
24	7091	Tool Tray
25	7092	Tool Tray Bracket
26	7100	Wheel Assy.
27	4776	Coil Box

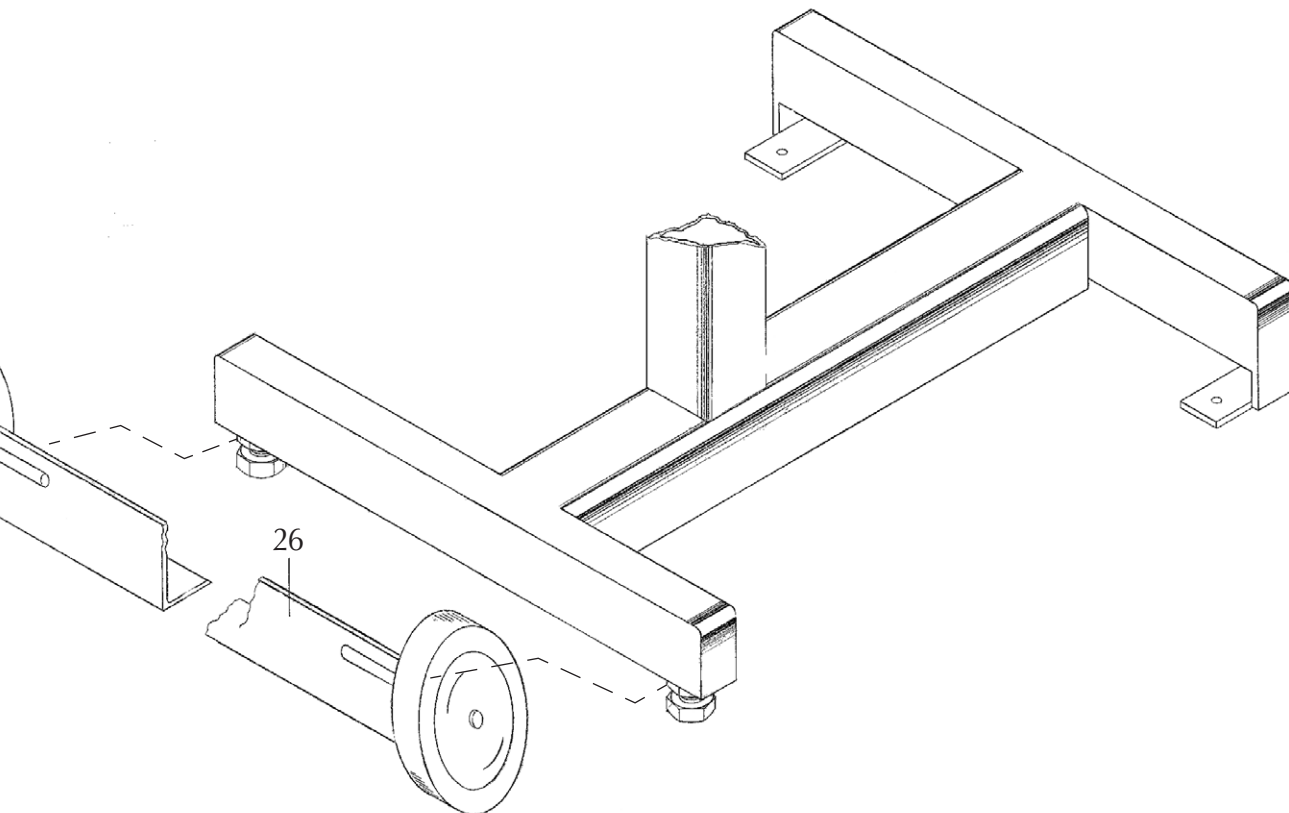

INSTALLATION & OPER

CAUTION: DISCONNECT POWER SUPPLY CORD FROM POWER SOURCE WHEN DOING REPAIR WORK ON THE MACHINE.

INSTALLATION

First, check machine over for any shipping damage. After the belt grinder is uncrated, a light weight hand truck can be used to move it around the shop. The motor end should be toward the operator as grinder is tipped back onto the truck. The motor operates on 115V AC 60 HZ, single phase power supply, and has an 8 foot long power cord. The front legs are provided with holes to take up to 3/8" diameter hold down bolts. Remove any tapes, straps or packing material from the grinder.

OPERATING INSTRUCTIONS

Note: Cost effective grinding depends on a few related factors. The grit size, material being ground, type of belt, belt storage, and how the work is presented to the belt influence the results you get from the grinder.

Start-up:

- 1) Check that the ON-OFF switch is in the OFF position.
- 2) Plug power cord into 115V AC 60 HZ single phase power receptacle.
- 3) Loosen the Belt Release Handle by turning counterclockwise and then retighten to check that belt is properly tensioned. See illustration in Figure 1 to identify parts.
- 4) Jog the motor to bring it up to speed gradually and watch that the belt is not tracking off the wheel. A full power start may cause the belt to track off.

— WARNING —

- Impact resistant eye glasses with side shields must be worn when grinding or working near the machine. A full face shield is preferable.
- Leather gloves and arm guards are also recommended.
- Use the grinder in a well ventilated area. The dust created when grinding some materials can be harmful. Dust masks are recommended to minimize dust inhalation.
- Flammable materials and fumes should not be present near the grinding machine.
- Familiarize yourself with the machine before attempting to use it.
- Do not remove cover and guards on the machine while doing grinding operations.
- Check that the drive pulley and the contact wheel are running true and do not wobble. Vibrations in the machine will prevent a good grinding finish.
- Check a new belt for nicks or cuts along its edge. Do not use if damage is evident.
- Use extreme caution when grinding magnesium. Magnesium dust can ignite. Have a bucket of sand close by to extinguish a fire.

SAFETY PRECAUTIONS

Abrasive belt grinding is the safest of all grinding mediums because of the inherently light weight of the belt and because of the relatively light pressures and tensions that the belt experiences. Nevertheless, safety measures must be practiced that apply to the hand grinding operations.

Belt Alignment Adjustment:

- 1) If the belt is tracking of the contact wheel toward the right, turn the belt alignment knob, Item 9, clockwise slowly until the belt tracks directly over the wheel.
- 2) If the belt tracks off toward the left, the belt alignment knob should be turned slowly counter-clockwise to bring the belt back in alignment.

Note: The moveable head with the contact wheel must be fully extended to provide the correct tension. Lock the belt release handle firmly to maintain proper belt tracking.

Belt Change:

- 1) Switch motor off and wait until belt has stopped moving.
- 2) Turn the belt release handle, Item 11, counter-clockwise as you face the handle to unlock the movable head.
- 3) Grasp the belt release lever, Item 17, and pull back as far as the movable head is allowed to go. Hold lever and lock head in this position by retightening the belt release handle.
- 4) Grasp the lower right hand corner of the hinged side cover and lift it up to rest on the hinge stop. Slide the belt off.
- 5) Check the new belt carefully. Do not use a belt with a nicked or cut edge or with handling damage.
- 6) Use only a 2 1/2" wide belt. A wider or narrower belt could cause snagging or throwing of the workpiece and damage to the contact wheel or the belt.
- 7) Look for an arrow marked on the inside surface of the new belt. The contact wheel and drive pulley rotate in a counter-clockwise direction. Not all belts have an arrow, but if one is marked on the belt, the arrow must point in the direction the belt will be traveling. See Figure 1 in the manual which indicates the direction of the arrow. Slide the new belt on the wheel and pulley. Center it.
- 8) Close the cover.
- 9) Hold the belt release lever to keep the movable head from jumping forward while releasing it with the release handle. Allow the head to move forward as far as it will go. Lock it in position with the release handle.
- 10) Jog the motor to bring belt up to speed. If belt is not tracking properly follow the procedure listed under heading of BELT ALIGNMENT ADJUSTMENT.

RATING INSTRUCTIONS

DUST FUNNEL ASSEMBLY INSTRUCTIONS

FRONT VIEW OF BELT GRINDER

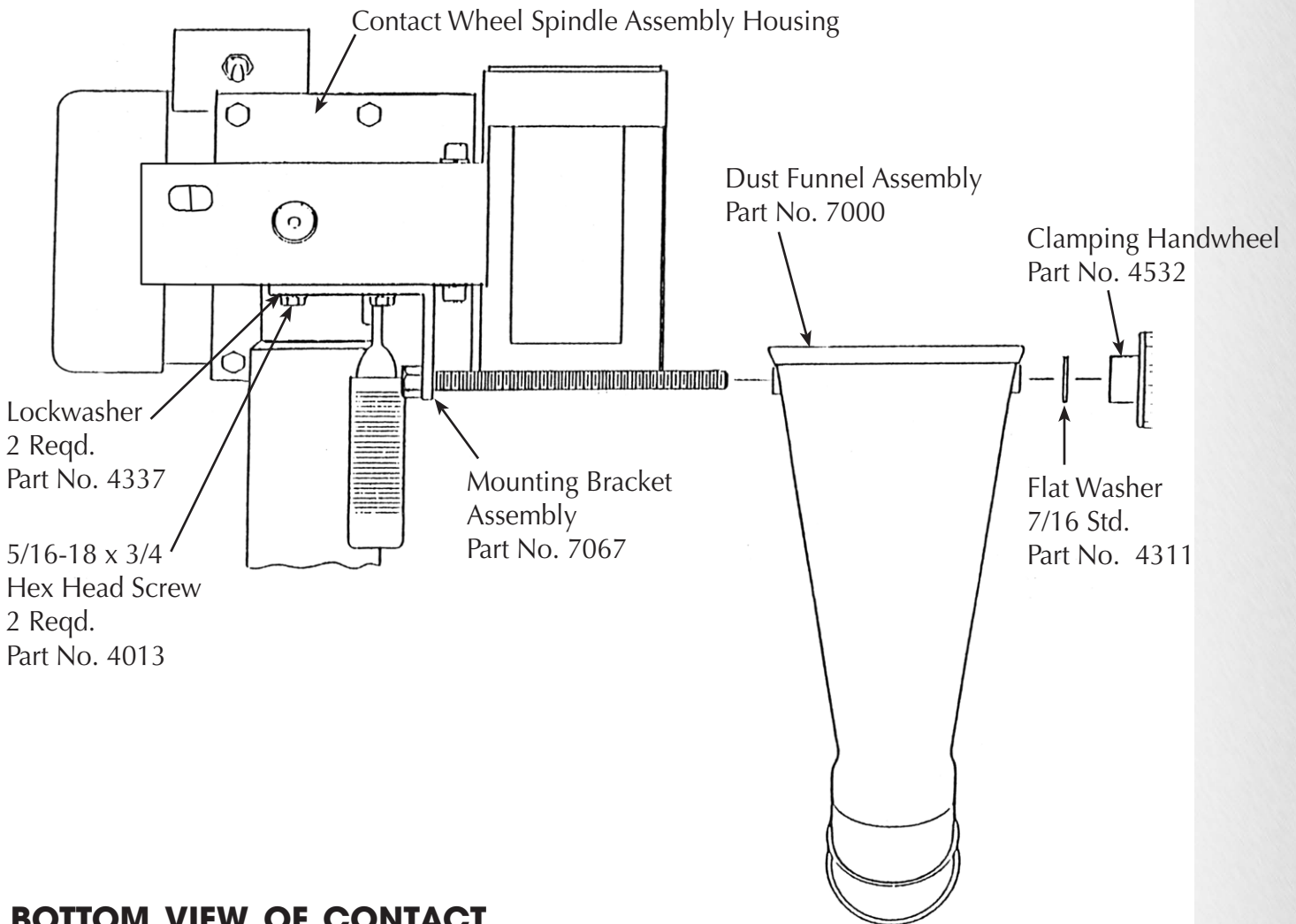

BOTTOM VIEW OF CONTACT WHEEL SPINDLE ASSEMBLY

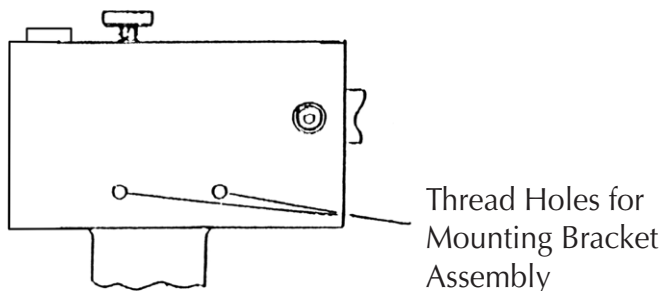

DUST FUNNEL KIT PART NO. 7620

Includes:

7075	7073	4013(2)	4001(3)
7067	7072	7000	7071
4311	4020	4532	4337(2)

GRAPHITE PLATE INSTALLATION

CAUTION: DISCONNECT POWER SUPPLY CORD FROM POWER SOURCE WHEN DOING ANY REPAIR WORK ON THE MACHINE.

Required Tools and Supplies:

- Ellis graphite replacement plate Part # 7037
- Sharp chisel
- Construction Adhesive
- Putty Knife
- 3 each 6R vise grips or similar clamps
- One piece of flat metal stock (approximately 1/2" x 2 1/2" x 12")

Step 1:

Disconnect the power supply cord from power source.

Step 2:

Remove the worn plate with a sharp chisel. Note the placement of this original plate and mark if necessary.

Step 3:

Clean the surface by removing all dirt, grease and oil from the top grinding surface with a suitable cleaner.

Step 4:

Using PL 200 Construction Adhesive or a similar brand, eject a thin layer of adhesive down the center of the top surface. Use a putty knife to spread the adhesive in a thin, even, layer over the area where the original plate was positioned.

Step 5:

Center the new plate on top of the adhesive over the original placement.

Step 6:

Center a flat metal stock (1/2" x 2 1/2" x 12") on top of the new plate and then clamp in the center and at each end. Let this dry for one hour.

Step 7:

Remove the clamps and flat metal stock.

Step 8:

Install a new belt.

ELLIS BELT GRINDER SPECIFICATIONS

Model No	6000
Belt Dimension	2 1/2" x 60"
Belt Grit	36 to 220
Belt Speed	5000 SFM
Platen Size	2 1/2" x 12 1/2"
Shipping Dimensions	Width — 24" Length — 30" Height — 48"
Shipping Weight	185 Lbs.
Motor	1 HP Special Duty, 3450 rpm Single Phase 60 Hz, 110/208, 230
Contact Wheel	Precision Balanced 6" diameter, 2 1/2" Wide 70 Duro, Serrated

ABRASIVE GRITS	
BELT GRIT	USAGE
36	ROUGH GRINDING - FAST STOCK REMOVAL DESCALING WELD GRINDING
50	
60	
80	SHAPING, CLEANING, FORMING, DEBURRING, BEVELING, CHAMFERING, DIMENSIONING
100	
120	
180	FINISHING POLISHING
220	

EYE SHIELD & LAMP ASSEMBLY

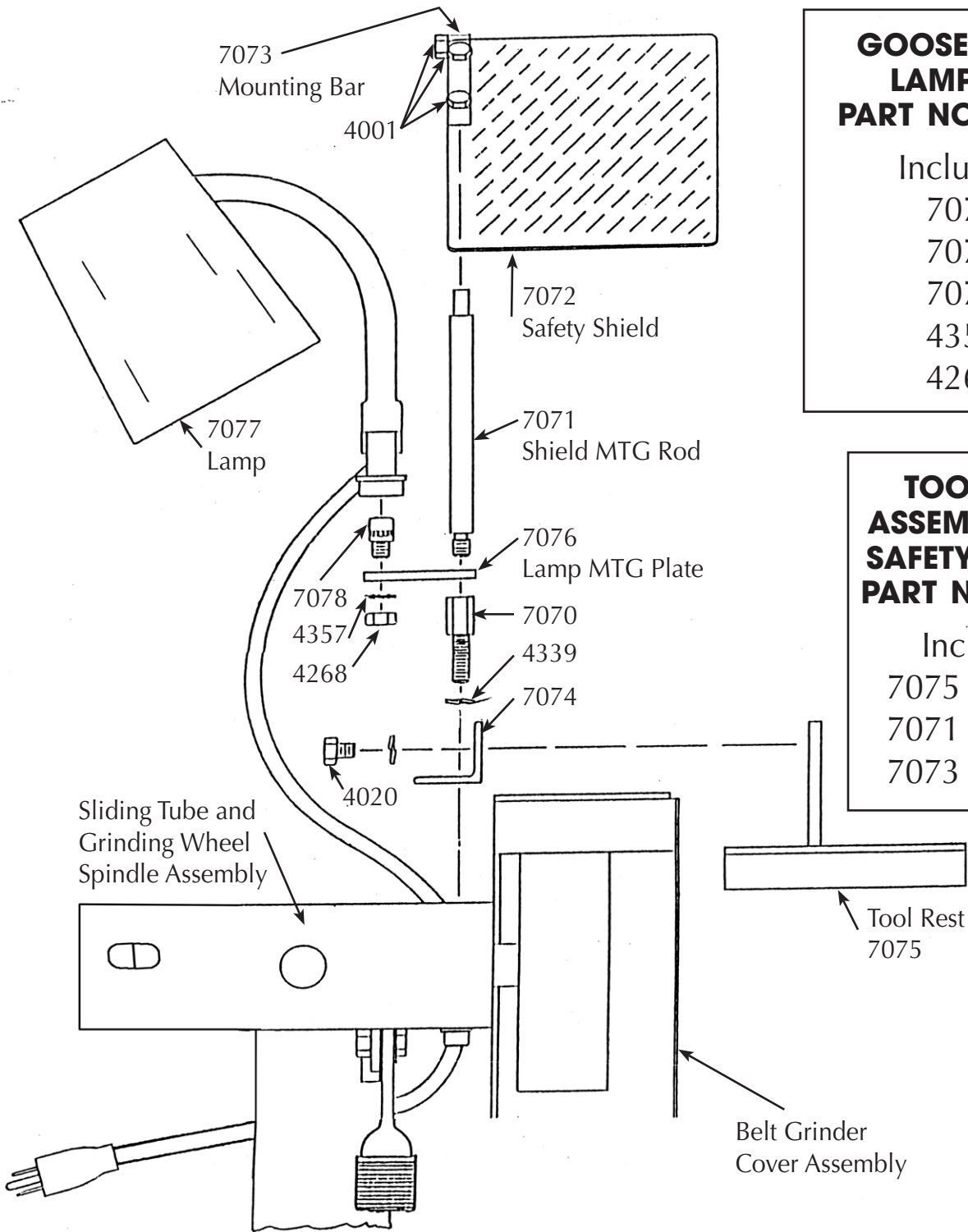

GOOSE NECK LAMP KIT PART NO. 6721

Includes:

7077

7078

7076

4357

4268

TOOL REST ASSEMBLY AND SAFETY SCREEN PART NO. 6720

Includes:

7075 4020

7071 7072

7073 4001(3)

ELLIS 6000 BELT GRINDER

GRINDING TECHNIQUES

Off hand Grinding

- All grinding should be done below the centerline of the contact wheel because it will be easier to hold the work and minimize chatter.
- Present the workpiece to the contact wheel in an upward motion to improve cutting and to draw the hands away from the abrasive belt.

Platen Grinding

- The platen is designed for grinding flat surfaces using light pressure.

Tool Grinding

- Use the tool rest 7075 for accurate grinding such as drill bits, chisels, etc.
-

REPAIR AND MAINTENANCE

Contact Wheel Spindle Bearing Replacement

- 1) To remove the bearings, first remove the contact wheel, Item 1, by loosening the set screw with a 5/32 inch hex key wrench. Refer to the parts catalog illustration.
 - 2) Next remove the socket head cap screws, Item 5 & 21, and the lock washers, Item 6, that secure Item 4 to Item 10. Use a 5/16 inch hex key wrench. Set these aside for reassembly.
 - 3) Slide the bearing housing and the spindle out and place on a bench.
 - 4) Loosen the set screw on each bearing collar, using a 1/8 inch hex key wrench.
 - 5) Slide the spindle out of the bearing housing. You may need to twist the collars and tap gently on the end of the spindle.
 - 6) The bearings are press fit into the housing. A bearing puller is the ideal tool to remove the bearings. Otherwise, use a driving punch to tap the bearing out from the opposite end. Tap gently and evenly around the bearing.
- Note:** Before replacing bearings, remove the collar from the bearing before pressing it into the housing. Use a large nut, ring or counter-bored bar that will be in contact only with the outer ring of the bearing and not touch the inner face or the protruding flange of the collar. The bearings at both ends of the housing have to be protected in this manner.
- 7) Use an arbor press to seat the bearings into the housing.
 - 8) Slide the spindle into the bearings so that the end at the rear of the housing is going to be flush with the bearing collar. If the spindle does not fit, remove the burrs on the spindle with a fine file.

- 9) Place the collars over the spindle and bearings. Rotate each collar individually on its bearing in the direction that the belt turns. That is, a counter-clockwise rotation as you face the contact wheel end of the spindle. Tighten the set screw using a 1/8 inch hex key wrench. Then use a prick punch and place it in the countersunk hole on the collar. Tap the punch lightly with a hammer so the collar is "set" in the counter-clockwise motion. Repeat with the other collar.
- 10) Replace the spindle and bearing housing assembly.
 - a) Place the spindle and bearing housing assembly into the Sliding Tube Assembly, Item 10, and line up the threaded holes on Item 4 with the holes in Item 10.
 - b) Place a lock washer, Item 6, over a socket head cap screw, Item 5 & 21. Insert the screw into the top hole in Item 10. Start the screw into Item 4, but only to depth of 1 or 2 threads. Repeat this procedure for the bottom hole.
 - c) Turn the top and bottom screws, alternately, equal turns, until the lock washers are compressed solid. Item 4 should be centered within Item 10.
- 11) Replace contact wheel
 - a) Place contact wheel, Item 1, on the spindle with the set screw side on the outside. Center the contact wheel with respect to the drive pulley, Item 15, by placing a 2 foot straight edge against the outside rim of the drive pulley. The side of the contact wheel should be set 5/16 inch away from the straight edge. Tighten the set screw on the contact wheel hub, using a 5/16 inch hex wrench.