

# GPS Vehicle tracker

(GPS+GSM+SMS/GPRS)

## User Manual



Please read this manual carefully before attempting installation. Pictures are for indication and illustration purposes only.

## 1. Accessories:



power cord(standard)

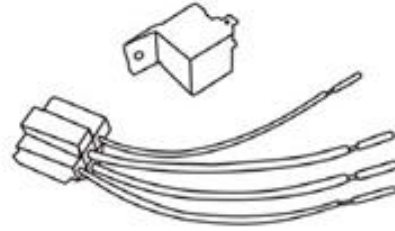

Relay(standard)



Microphone(standard)



SOS Alarm button  
(standard)

Please check the accessories before using. Pictures are for indication and illustration purposes only.

## 2. Features:

- GSM 850/900/1800/1900 Quad band
- .Easy voice instructing function
- Wide for voltage input range: 9-48 vDC/90mA
- GPS continuous positioning, GPRS timing interval
- Check location via SMS
- Built-in vibration sensor, theft proof
- ACC ignition detection
- Tele cut-off (petrol/ electricity) function
- Three SOS numbers in maximum
- SOS alarm and burglar alarm
- Voice monitor function
- Alarm when the power supply is disconnected intentionally (with back-up battery)
- Compatible with external connection through (serial port)

## 2.1 Red LED (power/working status)

LED Status	Meaning
Continuously bright	Charging
Continuously dark	Low battery / power off

## 2.2 Green LED (GSM status indicator)

LED Status	Meaning
Quick flashing	GSM initialization
Continuously bright	GSM conversation/Start GPRS
Continuously dark	No GSM signal

## 2.3 Blue LED (GPS status indicator)

LED Status	Meaning
Flashing	Searching GPS signal
Continuously bright	GPS located
Continuously dark	GPS not located

## 2.4 Ignition detection indication

Three (blue/red/green) LEDs are flashing in a cycle

### 3. Interface introduction



## 4. Method of installation

### 4.1. Preparation before installation

- 4.1.1 Open box to check whether the type of device is correct and whether the accessories are included, if not please contact your distributor.
- 4.1.2 Choose a SIM card: each device needs a GSM SIM card inserted. Please refer to the distributor's suggestions to choose the SIM card.
- 4.1.3 Installing the SIM card: The SIM card slot is on the right side of device. Open the SIM card silicon seal, then insert the SIM card into the slot (do not insert the SIM card backwards). When the SIM card is ready you will hear a click. If not, please insert again and then replace the silicon seal.

#### Note:

Please use a GSM network SIM card;  
Power off before installing or removing the SIM card.  
The SIM card used should be enabled for GPRS.  
The SIM card used should be enabled for caller ID.  
If the password or the pin is enabled, please disable it;  
Ensure the SIM card can send and receive SMS.

### 4.2 Installation

Device installation is covert. Please refer to an auto electrician for installation.

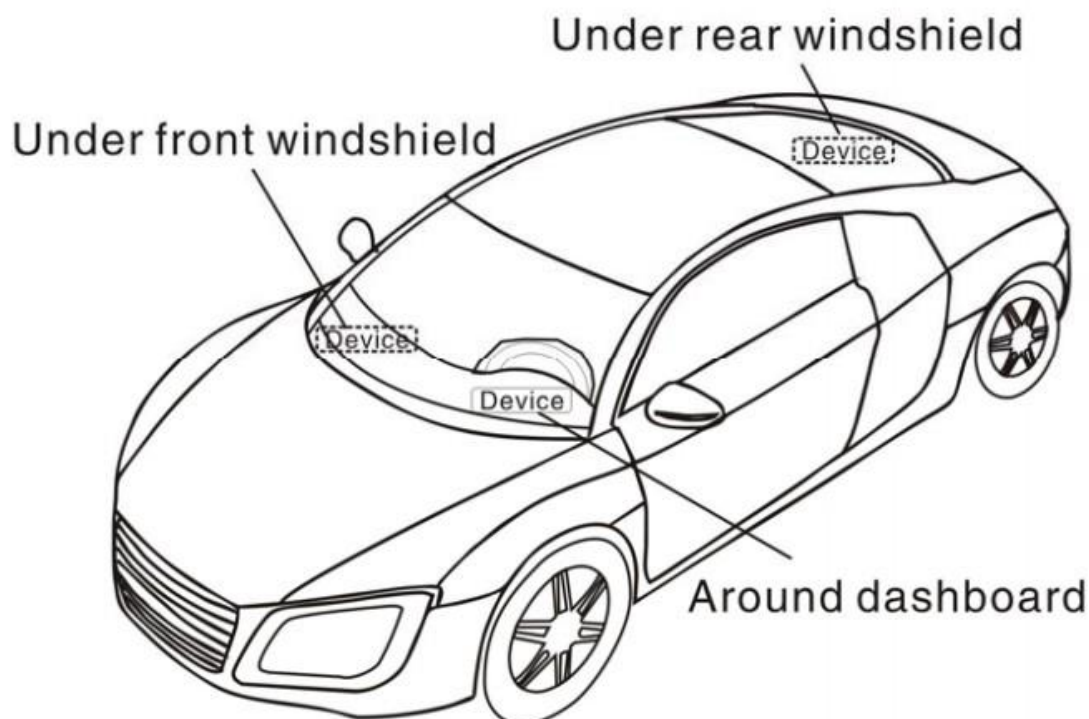

NOTE:

4.2.1 To prevent theft of the device, it should be installed as covertly as possible.

4.2.2 Avoid placing the device close to higher power electrical devices, such as parking sensors, an anti-theft device or other vehicle communication equipment;

4.2.3 The device should be fixed into position with cable ties or wide double-side tape.

4.2.4 The device has a built-in GSM antenna and GPS antenna. During installation, please make sure the receiving side is face up, with no metal object above the device to interfere with GPS reception. The following places are suggested for installation:

-shelter in the decorated board below the front windscreen;

-shelter around the front instrument panel (non-metallic material face);

-in the decorated board below back windscreen.

Notice: if the windscreen is coated with metal thermal-protective coating or heating coating, It may affect the signal. In this case, please change the place of installation.

### 4.3 Device outlet specification

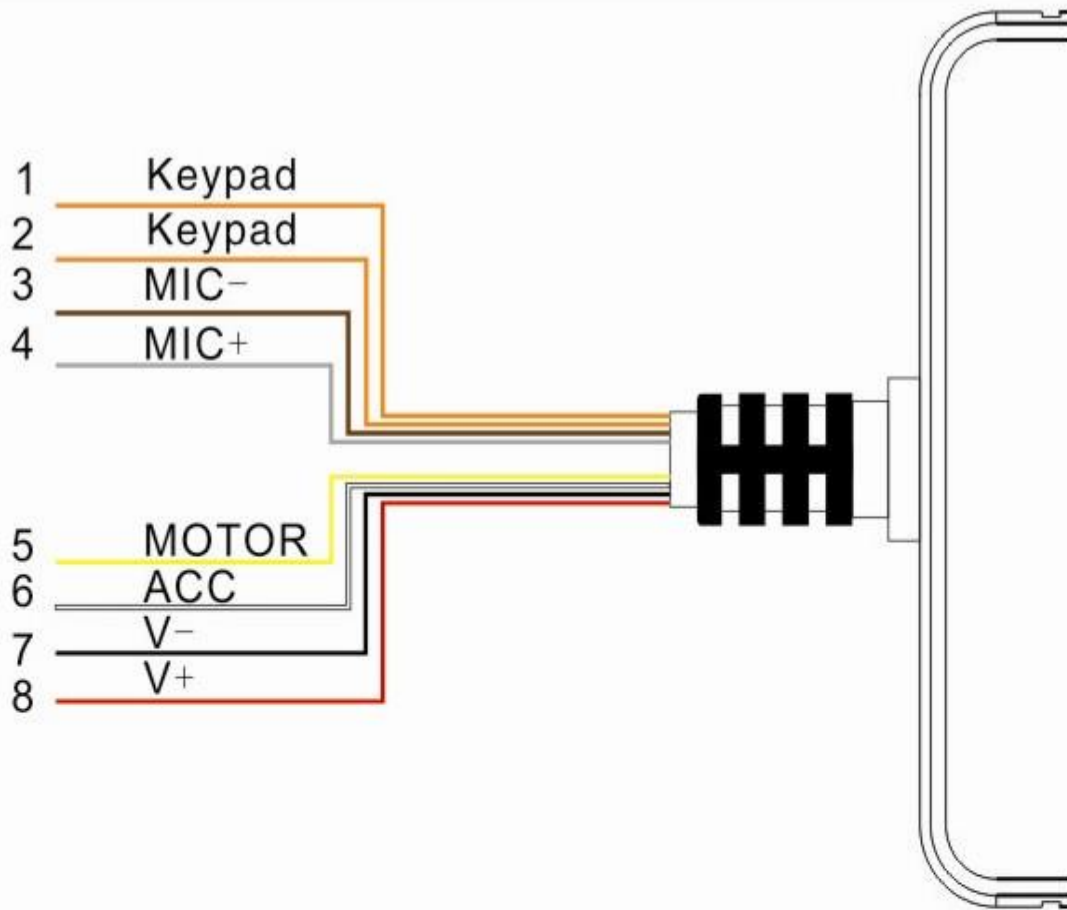

Line No.	Specification	Color	Instruction
1. 2	Keypod	Orange/ orange	Connect to SOS button
3. 4	MIC-,MIC+	Brown/grey	Connect to Microphone
5	MOTOR	Yellow	Connect to relay control line
6	ACC	white	Connect to ACC ignition
7	V-	Black(thick)	Vehicle 12V/24V negative storage battery
8	V+	Red(thick)	Vehicle 12V/24V positive storage battery

#### Notes for relay wiring

The relay wiring of pump: oil connectors of both ends are a fine white line (85) and a fine yellow line (86). The fine white line (85) is connected to vehicle positive power (+12V). The fine yellow line is connected to the device relay control line. Cut off the positive connection line of the pump; then connect in series to the relay N.C. contact (thick green line 87a) and the other end to relay COM contact (thick green line 30).  
 Note: The standard relay is 12V and only suits the 12V car battery. Please choose 24V relay if it is 24V car battery



#### 4.4 Device wiring diagram

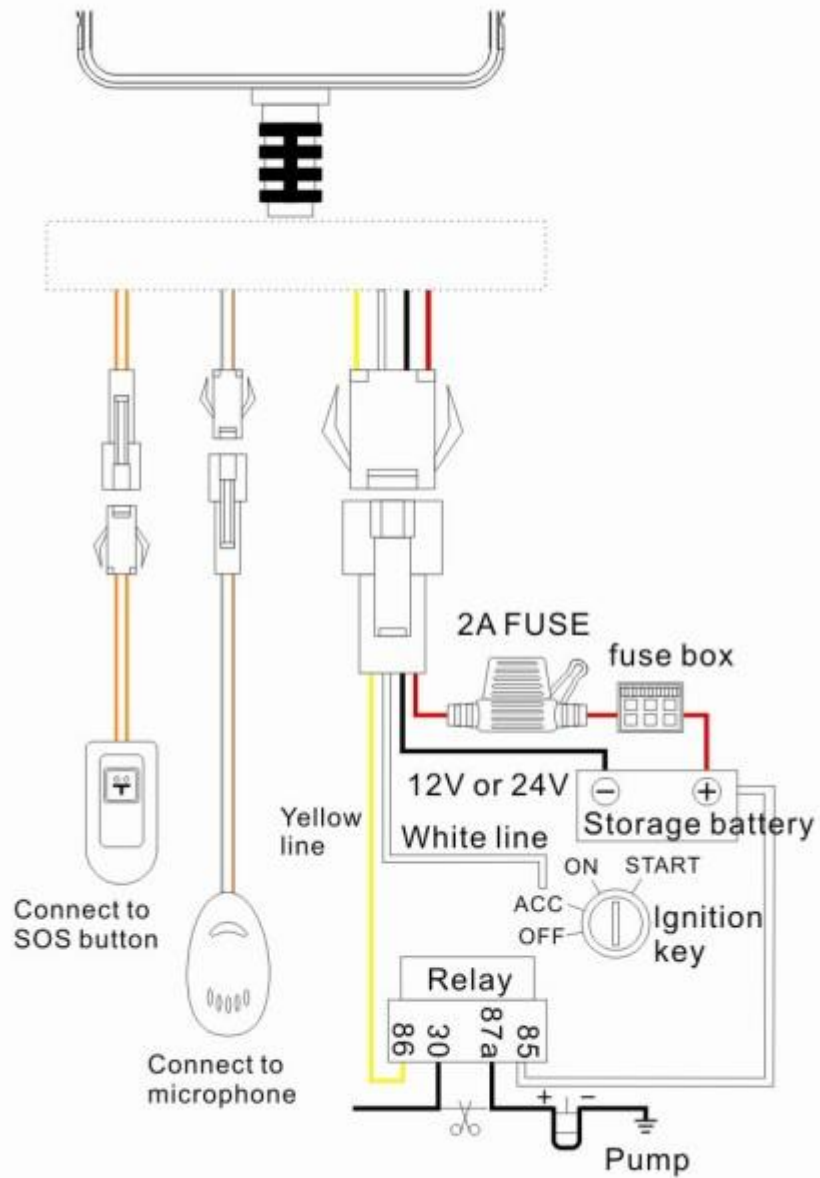



## **5. Cautions of device wiring**

### **5.1 Power/ACC/Tele cut-off (petrol/electricity) control line (4 pin)**

5.1.1 Standard voltage is 9V-48VDC. Please use the power line which is provided by the manufacturer. The red line is the positive. The black line is the negative. The negative should earth alone or link iron during installing. Do not connect it to another ground wire.

5.1.2 ACC line (white) is connected to the ACC switch of the vehicle. Please make sure to connect the ACC line. The tracker will decide whether to enter ignition detection according to ACC status. If you do not connect to ACC line, the device will enter ignition detection status. If the vehicle vibrates when moving, it will activate the vibration alarm. If there is no need for the theft proof function, connect the ACC line to the positive in parallel and keep high level.

5.1.3 Tele cut-off (petrol/ electricity) control line (yellow) is connected to pin 86 of the Tele cut-off (petrol/ electricity) relay (equal to the yellow line of the relay socket).

### **5.2 MIC line (2 pin)**

Externally connect to microphone for voice monitor function

### **5.3 SOS line (2 pin)**

Externally connect to SOS switch for SOS function.

## 6. Parameter setting

The SMS command format is not case sensitive and is divided by a comma. You should receive a reply SMS after sending the command. If set successfully, there will be a corresponding reply SMS; if not please set it again. Any phone number can send an SMS command to the device as default.

### 6.1 APN setting

**6.1.1** Normally, the device can search and set the APN automatically, or it can be set manually.

The APN of many countries mobile networks are stored on the tracker, for example: For the UK, we have included the APN of "o2", "VODAFONE" and "ORANGE." If you choose to use one of these networks, you do not need to set the APN manually. When the sim card is inserted, the device will recognise the network sim card and set the APN automatically.

If you wish to change your network and have a pre-set APN, you will first need to delete this before a different network sim card can be used. To clear the current APN setting, please SMS: **\*APN,0#**

APN command format Examples:

Text : **\* APN,APN's Name,IP,PORT#** (Here the IP and PORT is the SIM card's IP and PORT)

**For o2 sim card:** **\*APN,payandgo.o2.co.uk,0.0.0.0,0,payandgo,payandgo#**

The device will reply "APN has been set! APN is:  
**payandgo.o2.co.uk,0.0.0.0,0,payandgo,payandgo#**

For T-mobile sim card: **\*APN,mobile.o2.co.uk,10.0.0.172,80**  
("mobile.o2.co.uk" is the APN of the carrier, the APN varies with your mobile network provider)

The device will reply "APN has been set! APN is:  
mobile.o2.co.uk,10.0.0.172,80." if set successfully.

**6.1.2** To clear APN setting, please SMS: **\*APN,0#**

Note: The APN of some countries have a user name and password, you may need to send the SMS command as follows:

**\*APN,APN name,IP,PORT,user name,password #**  
E.g: **\*APN,CMWAP,10.0.0.172,80,CLIENTE,AMENA#**

## 6.2 DNS setting

The tracker is connected as default to the platform [www.gpsgreat.com](http://www.gpsgreat.com)

To connect to another platform, please send the SMS command below to change the settings:

### 6.2.1 Via DNS: **SERVER,0,DNS,Port,0#**

Eg: SERVER,0,www.gpsgreat.com,88,0#

If set successfully, you will receive the reply: "IP :www.gpsgreat.com Port :88"

### 6.2.2 Via IP: **SERVER,0,IP,Port,0#**

Eg: SERVER,0,58.64.200.64,88,0#

If set successfully, you will receive the reply: "IP : 58.64.200.64 Port :88"

## 6.3 Add specific number

To set an SOS number you will need to set up the device via SMS

Please send the following SMS: **SOS,A,No.1,No.2,No.3#**

"A" means to add new numbers, for example:

SOS,A, 07900000001,07900000002,07900000003#

If there is only one SOS number, you can appoint a specific number as SOS number. The hash tag means that no number will be further added.

For example:

SOS,A, 07900000001# means to set the first number as SOS number

SOS,A,, 07900000002# means to set the second number as SOS number

SOS,A,,, 07900000003# means to set the third number as SOS number

If set successfully, you will receive the following reply via SMS:

"SOSnumber: 07900000001,07900000002,07900000003"

## 6.4 Delete specific number

Before deleting a specific number, please check its corresponding code. For the code, please send the following SMS "**PARAM#**" to the device.

You will then be able to command the device to delete the number.

"D" means to delete the number, for example:

**SOS,D,1#** means to delete the first number

**SOS,D,3#** means to delete the third number

If you want to delete more than one number, you can send this command:

**SOS,D,1,3#** means to delete the first and third numbers.

If you forgot the serial number of the mobile number you want to delete, you can send this command:

**SOS,D,mobile number#** and this will delete the mobile number directly.

For example:

SOS,D, 07900000001# means to delete the number 07900000001 directly.

After deleting the SOS number, you will receive an “ok” message in reply having successfully deleted the specific number.

## 6.5 Set the center number

If you want to cut-off/restore the engine by SMS command, you will firstly have to set a center (main) number. Only the center number can send the cut-off/restore the engine command to the device. You can set your own mobile number as the center number.

The command format for setting the center number is:

**CENTER,A,mobile number#**

For example:

CENTER,A,07900000001#

If set successfully, you will receive an “OK” message in reply.

**Note:**

Only an SOS phone number can send the command to successfully set itself as a center number. Only one center number can be set.

## 6.6 Delete the center number

Command the device via SMS to delete the center number.

The command format is:

**CENTER,D#**

If set successfully, you will receive an “OK” reply via SMS.

**NOTE :** Only an SOS number can be used to delete center number successfully.

## 6.7 GPRS time interval

The default GPRS time sending interval is 10s which means the device will upload positioning data to the platform server every 10s. Users can modify the

GPRS sending time interval via SMS by sending “**TIMER,time(seconds)#**”.

The time ranges from 10-1800 seconds

For example: **TIMER,10#**

This would mean the device will upload data to the server every 10seconds.

**NOTE:** To turn off GPRS function just SMS “**TIMER, 0#**”.

## 6.8 Sensor alarm time setting

When the vehicle power is off and ACC is at a low-level, if the ACC is off for over 10 minutes, the device will enter sensor alarm state. In this case, if the vehicle vibrates a few times, it will activate the vibration alarm system. If the vehicle battery is still not on (ACC is at a low level) after 3 minutes, the device will start the vibration alarm.

SMS format: “**DEFENSE,TIME(minutes)#**” The time ranges from 1 to 60 mins.

For example: DEFENSE,15#. This means that when ACC is at a low level for 15mins, it will enter sensor alarm status (vehicle power is off)

**NOTE:**

1. Preset SOS numbers when sending SMS alarm messages .
2. If there is no need for a vibration alarm, please SMS "SENSORSET,0#" to stop it.

## 6.9 Sensor detecting time and alarm delaying time setting

For setting sensor detecting time and alarm delaying time please send command in this form: **SENSOR, detecting time, delaying time#** (The range is 1-999s; 10-300s).

For example: If you send the command "SENSOR, 10,180#", it will reply: "Sensor time interval:10,180", which means that once the device vibrates for 10s, it will activate the vibration alarm unless the ACC is turned on in 180s.

## 6.10 Restore to factory settings

SMS command: "**FACTORY#**" to set all parameters to default factory settings. You will receive an "OK" message via SMS if factory reset is successful.

## 6.11 Reboot device

When there is something wrong with the link of GPRS, e.g., The parameter settings of the device are correct, but you can't track the car on the platform. You can send a command to the device to reboot.

The command is: **RESET#**

After receiving this command, the device will reboot after 30 seconds.

## 7. Parameter Checking

### 7.1 Check parameter settings

Command the device via SMS to check the device settings.

Command format: **PARAM#**

e.g.: PARAM#

Reply information:

**IMEI:** 500050300009180 (IMEI number of the device)

**GPRS Interval:** 10; (GPS data uploading Interval, the time ranges from 10-18000s, default as 10s)

**TIMESET:20;** (the GPS working time when ACC is OFF, the time range from 1-999mins(default as 20 min))

**SOS Number:** 1. 079xxxxxxxx

2. 079xxxxxxxx

3. 079xxxxxxxx (a maximum three SOS numbers used for alarm)

**Center Number:** 079xxxxxxxx (only one center number used for cutting off and restoring oil command)

**Sensor time interval:**10,180; (sensor detecting time, default as 10s; vibration alarm delay, default as 180s; the time ranges from10-300s)

**Sensor alarm time interval:**10; (sensor alarm time interval, the time ranges from 1-60mins; default as 10mins)

**TimeZone:**E,8; (set time zone; default as E8)

The SMS will be ordered as follows:

IMEInumber/GPRSInterval/TIMESET/SOS/CENTERnumber/Sensortimeinterval/Sensor alarm time Interval/TimeZone

### 7.2 Check GPRS parameters

SMS command format: **GPRSSET#**

eg: GPRSSET#

Reply message format:

**GPRS:ON** (GPRS on/off status)

**APN,mobile.o2.co.uk,0,0.0.0.0,,;** (APN setting information)

**Server:www.gpsgreat.com,88;** (platform information)

**URL:http://maps.google.com/maps?q=;** (preset web link setting information)

**Overspeed:60,0** (over speed alarm setting information)

**Fence: Disable** (fence alarm setting information)

**Call alarm Disable** (call alarm switch information)

### 7.3 Check the mileage/ clear the mileage

To check the mileage, you can send this command : **GETMILEAGE#**

You will receive a reply, e.g. "The total mileage is: 252km" which means the car has already been driven for 252km.

To clear the mileage, you can send this command: **CMILEAGE#**

You will receive the reply: "The total mileage is:0km."

## 7.4 Check version

To check the version of the device's software, send this command: **VERSION#**.  
You will receive a reply: e.g. “<Version>TR06N\_V2.0.8, 2013.7.30”

## 7.5 Check the status

To check the device's status, you can send this command: **STATUS#**

You will receive a reply: e.g.

**“Battery: FULL**

**GPRS: Link up;**

**GSM Signal Level: Strong**

**GPS: Successful Positioning**

**ACC: ON**

**Defense: OFF**

**OilPowerControl:ON**

**Sensitivity of vibration: 5”.**

## 8. Operation of device

New voice instructions for controlling main functions.

Use the SOS number to dial the number of the SIM card which is inserted in the device, you will enable voice monitoring mode and will hear the following instructions:

**for voice monitoring , press 1**

**for track location message, press 2,**

**for cutting-off the power (engine) and electric, press 3**

**for restoring the power and electric, press 4**

**for repeating the current directory, press 0**

**to finish please hang up, thank you**

Select the option of your choice via your phone keypad.

Note: Only SOS number can dial the number of device.

### 8.1 Power on/ Power off

**Power on:** Having inserted a valid SIM card and connected all the wires, turn on the device, the Power LED will flash first, whilst searching for signal, the GSM and GPS LED will flash. Once the GPS LED stays solid, it means the device has been located and will start to work.

**Power off:** Just turn off the power switch.



## 8.2 Check location

### 8.2.1 Via phone:

Dial the number of the device via your land-line telephone or mobile, and press “2” according

to the voice instructions, the device will send a location message automatically.

Note: The location SMS from device will only send to a mobile phone or telephone with SMS function. It cannot be sent to a land-line telephone without SMS capabilities.

### 8.2.2 Via SMS

**8.2.2.1** SMS “**WHERE#**”, to the SIM number of tracker. The device will send a location message automatically. You can get the coordinates.

Example:

Lat:N22.571285,Lon:E113.877115,Course:42.20,Speed:0.0740,DateTime:10-11-23 22:28:51

**8.2.2.2** SMS “**URL#**”, to the SIM number of the tracker. The device will send a location Google Map link.

Example:

<Date Time: 10-11-23 23:42:51> <http://maps.google.com/maps?q=N22.571490,E113.877103>

### 8.2.3 Via platform

Go to the platform website to check your vehicle location.

## 8.3 Voice monitoring

### 8.3.1 Via Phone

Dial the number of the tracker via your land-line telephone or mobile, and press “1” in accordance with the voice instructions. You will hear the voice around the device automatically.

Note: The SIM card put into the device should have caller identification enabled.

### 8.3.2 Via SMS

After successfully receiving the message “**LISTEN#**”, the device will call back within a few minutes. Just answer the phone and you will enter the voice monitoring state directly.

## 8.4 Power (Engine) cut-off

### 8.4.1. Via phone:

Dial the number of the tracker via your land-line telephone or mobile, and press” 3 “ in accordance with the voice instructions. The engine will be cut off automatically.

### 8.4.2. Via platform

Send an oil cut-off command from the platform. The tracker can only command to cut off oil when there is a valid GPS position. You will need a platform account username and password to send an oil cut off command.

### 8.4.3. Via SMS

Firstly, you should set a center number. Only a center number can send the command to the device to cut off and restore oil.

The format is: **RELAY,1#**

After the command is carried out, it will reply “Cut-off the fuel supply: Success!”. If the command was unsuccessful, it will reply with the reason.

Notice: After cutting off power, the vehicle will be partly out of control, so be more careful when using this function. The engine can only be cut-off if the speed of your vehicle is under 30km/h and in safe position. We advise that this function should only be used when the vehicle is stationary.

## 8.5 Restoring power (Engine)

### 8.5.1. Via phone:

Dial the number of the tracker via your land-line telephone or mobile, and press “4” in accordance with the voice instructions. The power (engine) will be restored automatically.

### 8.5.2. Via platform

When the alarm is off, send a power restoration command manually. The tracker will restore the fuel supply, and vehicle will work normally again.

A platform account and password is needed when sending a power cut-off command.

### 8.5.3. Via SMS

Only a center number can send the command to the device to restore power. The command is: **RELAY,0#**

After the command is carried out, you will receive the SMS “restore fuel supply: success!”

## 9. Device alarms

### 9.1 SOS alarm

In an emergency, press SOS for 3 seconds to activate the SOS alarm. The device will then send an SOS SMS to the specific preset numbers and then dial the numbers repeatedly until the call is through. In the meantime, the device will upload SOS alarm data to the server, it will send:

SOS Alarm ! Date Time: 13-08-22 23:42:51, <http://maps.google.com/maps?q=N22.571490,E113.877103>

Note: The specific numbers should be preset, please refer to 6.3.

### 9.2 Wire cut-off alarm

When the electricity supply of device is cut-off, it will activate the cut-off alarm.

In

this case, the device will send a related SMS to the specific numbers and dial the numbers repeatedly. If nobody answers, the call will loop 3 times at the most. In the meantime, the device will upload SOS alarm data to the server and will send:

Main Power has been cut off, Alarm! Date Time: 13-08-22 23:42:51,  
<http://maps.google.com/maps?q=N22.571490,E113.877103>

You can also send the command “**CALLALARM,ON#**” to open phone call alarm function and send the command “**CALLALARM,OFF**” to close it.

Note: Normally we don't suggest to open phone call alarm function.

The specific numbers should be preset, please refer to 6.3 .

### 9.3 Low battery alarm

When the device is only working with battery, once the internal voltage of battery is less than 3.7V, device will send a low battery alarm SMS to a specific number and alarm on the platform.

Low battery alarm SMS example: “Battery low Alarm! Date Time: 13-08-22 23:42:51, <http://maps.google.com/maps?q=N22.571490,E113.877103>.” This means the battery is too Low and informs the user to charge it as soon as possible.

Note: The specific numbers should be preset, please refer to 6.3

### 9.4 Vibration alarm

When the vehicle power is off and ACC status is also low, and if the amount of time the ACC is low exceeds 10 minutes (this time setting can be changed), the device will activate a security alarm. When the security alarm is on, once the vehicle vibrates several times, the alarm will be activated, if 3 minutes later, the vehicle power is still off (ACC status is low) the device will start the alarm. At this time, it will send an alarm SMS to the SOS number, and dial the SOS numbers repeatedly until through. If nobody answers, the call will loop 3 times. The tracking platform will also receive a vibration alarm message.

e.g.: Vibrate Alarm! Date Time: 13-08-22 23:42:51, <http://maps.google.com/maps?q=N22.571490,E113.877103>

Note: The specific numbers should be preset, please refer to 6.3.

SMS “**SENSORSET,0#**”to turn off the vibration alarm.

### 9.5 Set speed alarm warning

To set speed alarm function, please send the following command to the device:

“**SPEED,time,speed#**” (the range of time is 1-10mins,the unit of the speed is “km/h”)

For example: If you send the command ”SPEED, 3, 60#”, it will reply:

“Over speed: 60km/h ; duration is 3min”, which means if the speed of the vehicle is over 60km/h for more than 3mins, it will send alarm message to SOS specific number:

Eg:

Over speed Alarm! Date Time: 13-08-22 23:42:51,<http://maps.google.com/maps?q=N22.571490,E113.877103>

To close the over set speed alarm function, SMS:”**SPEED,0,0#**”

## 9.6 Fence alarm

To set a fence alarm function please send the following command:

**"FENCE, ON ,0, latitude,longitude,radius,IN(OUT)#"**(the unit of the radius is "km")

For example: If you send the command: "FENCE,ON ,0,23,114,10,OUT#", it will reply: "fence:23,114,radius: 10km, Out" which means if the vehicle moves outside of the circle of which center is "N23,E114" and the radius is 10km, it will send alarm message to the SOS number:

Eg: "Go out Fence Alarm! Date Time: 10-11-23 23:42:51,http://maps.google.com/maps?q=N23,E114"

To set the vehicle's current position as the center of the fence, please send command in this form: **"FENCE,ON,0,0,0,radius,IN(OUT)#"**

To close fence alarm function, SMS: **"FENCE, OFF#"**.

Note:

You can also set the Fence on the platform, but only the platform will get the alarm message.

## 10. Web based tracking

The GPRS web based tracking platform allows real time tracking with the latest Google maps. There is also a playback feature which allows you to view where the vehicle has been for the last 60 days making it ideal for fleet management.

## 11. Trouble shooting

11.1. If after the first installation, the device cannot connect to the platform server, it will be shown as "logged off" on the platform.

Please check the installation of the tracker:

- 1) Check whether the connection of power-line is correct, please do not connect it with the car control line.
- 2) Check whether the SIM card is installed correctly, please refer to the installation manual;
- 3) Check whether the power switch is toggled to "ON".
- 4) Check whether ACC ignition cable is connected; please turn on the ACC with your key after it is connected.
- 5) Check the LEDs' status. If working, the red LED is solid on, the green LED and blue LED are also both solid on.
- 6) Check whether GPS is located, if not, please drive to open areas for positioning.

11.2 If it is "offline" on the platform:

First of all, check the three LEDs' status. If these are not convenient to check, please check the SIM card status:

- 1) Call the SIM card number of the device to check whether you can get through;
- 2) Check whether the vehicle is in a no GSM area, such as a basement;
- 3) Check the GSM/GPS connection area and whether all other devices or a

few of them are disconnected, to make sure whether it is the fault of the mobile operator's connection.

- 4) Check whether your SIM card needs topping up;
- 5) Check whether the SIM card supports GPRS;
- 6) Check the parameters setup, whether the device IMEI number, GPRS sending interval is correct;

11.3 If the tracker's GPS function is normal, but cannot be located for a long time, please check whether the tracker has been installed correctly:

- 1) Please make sure the GPS antenna is face up;
- 2) Please make sure there is no electromagnetic wave- absorbent object (metal) above the device, especially thermal-protective coating on the windscreen as this may affect the GPS reception of the device;

11.4 If the GPS cannot receive signal normally (e.g. there are high buildings around to interfere with GPS reception), please drive to open areas for positioning. Generally, it needs 3-5 minutes to receive the first coordinates.

11.5 If the GSM cannot receive the signal normally, please check whether the SIM card is installed correctly or if there is GSM signal at the location you are, e.g. basement parking, please drive to a place with GSM signal reception.

11.6 When an SOS mobile receives a tele cut-off alarm SMS, please check whether it is an illegal wire cut-off, or the FUSE on power line is blown. If the FUSE in it is blown, please contact your distributor to exchange with the same model FUSE.

Additional information:

There are many functions you can use on your web portal. There is a playback feature which allows you to view where the vehicle has been for the last 60 days.

The 'Show LBS' function on the top right corner of your portal tracks via the GSM base station. This can be used when there is no GPS signal but when there is likely to be GPRS signal, for example when the vehicle is in a garage or in a covered car park. The tracker will be tracked by LBS (sim card).

"S" means start, "P" means parking.

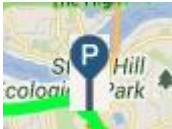

## Warranty card of GPS Vehicle tracker

Special statement:

1. Specifications of this product subject to change without further notice.
2. Any change about the appearance and color is subject to the real object.
3. Warranty card applies to the product with the IMEI number listed below.
4. Please keep this card safely for after-sale service, as well as your receipt.
5. Refer to the table below for the warranty reference.

This card is the basic certificate for warranty, please fill it carefully and keep it safely.

Customer Name		Phone number	
Customer Address			
Model Number		IMEI number	
Date of Purchase		Invoice number	
Device Sim Number			
Sim/Network Provider			
Customer e mail address			
	<p>1. The tracking device is guaranteed for one year for any manufacturer fault.</p> <p>2. The below are not within the scope of the warranty;</p> <p style="margin-left: 20px;">(1) disassemble or maintain without authorisation;</p> <p style="margin-left: 20px;">(2) immersion, break or burn of circuit board;</p> <p style="margin-left: 20px;">(3) damages from improper installation, use, maintenance or storage</p> <p style="margin-left: 20px;">(4) damage of shell, lens or internal antenna;</p> <p style="margin-left: 20px;">(6) IMEI number is torn or faded;</p> <p style="margin-left: 20px;">(7) warranty certificate is inconsistent with product model, or the certificate is altered;</p> <p style="margin-left: 20px;">(8) damages due to force majeure</p> <p><b>Terms and Conditions for Sale of Goods of Knowledge Master UK Ltd applies. Please visit our website, <a href="http://www.navigationmaster.com">www.navigationmaster.com</a></b></p>		

## Maintenance records

Record one			
Maintenance unit		Date	
Fault description			
Maintenance status			
IMEI number		Serviceman	

Record two			
Maintenance unit		Date	
Fault description			
Maintenance status			
IMEI number		IMEI number	