

PALCO FULL COLOR +

- GB
- I
- D
- F
- E
- P

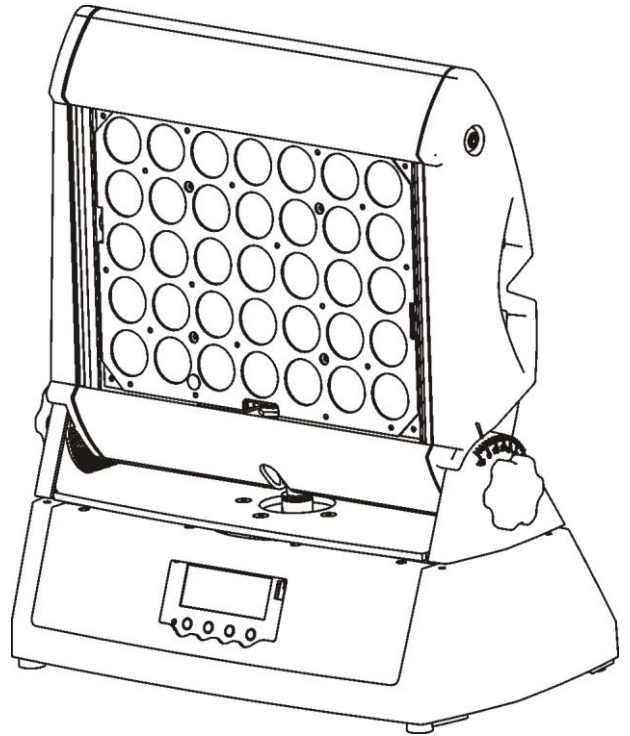

Thank you for your patronage. We are confident that our excellent products and service can satisfy you.

In order to install, operate, and maintain the lighting safely and correctly, we suggest to have verified technicians to install the item and to strictly follow the instructions.

INTRODUCTIONS:

Thank you for choosing the professional led color changer.

You will see you have purchased a powerful and versatile device.

Unpack the device. The package contains:

1. One XLR waterproof connection cable
2. One waterproof power cable
3. One safety rope
4. Manual

Below are the optional accessories that can be purchased from your local dealer.

1. Remote Controller

Please carefully check that the package is intact after transportation. Should there be any damage, consult with your dealer and don't install the device.

Features:

- Equipped with 105 LEDs: 35 x 3W red, 35 x 3W green , 35 x 3W blue
- 100 000 hours LED life
- DMX Channel modes: 8 DMX channels selectable for several applications
- 1-18 flashes per second strobe-effect
- General dimming and blackout for all three effect
- Excellent RGB mixing and rainbow effect
- Friendly blue and white LCD display
- Dimmer: 0-100% linear dimming
- Software-upload by optional accessory via DMX line

OVERVIEW

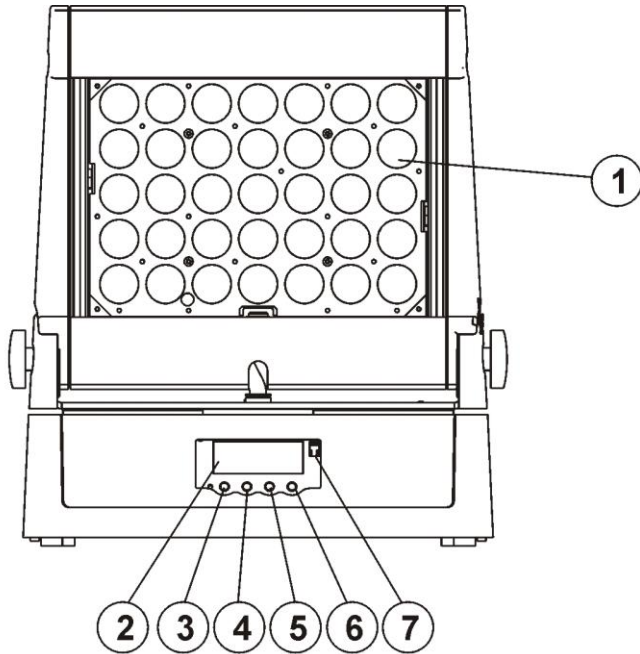

- 1) LED
- 2) LCD-Display
- 3) Mode/esc-button
- 4) Up-button
- 5) Down-button
- 6) Enter-button
- 7) IR

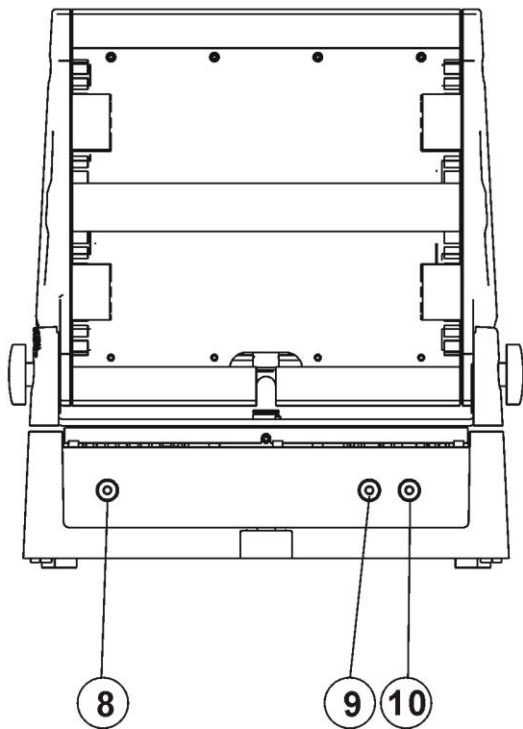

- 8) Power input
- 9) DMX-input
- 10) DMX-output

User manual of telecontrol

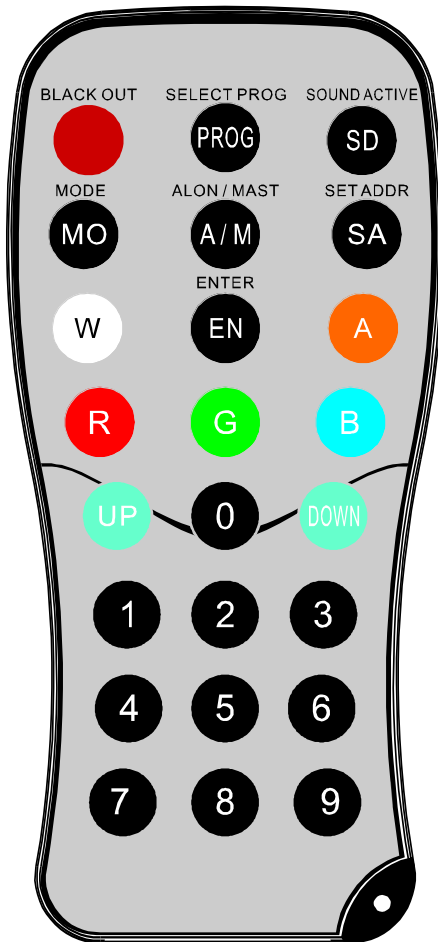

BLACK OUT : The lamp will be turned off after having pressed the button and exit to the status of Address Display. Press BLACK OUT+ 0 to reset to the initial status of infrared setting.(except address).

PROG AUTO RUN : Press this button to enter the built- in program.

SD SOUND ACTIVE : Press this button to enter the sound active (it depends on whether this function exists in the lighting fixture).

MO MODE : Every lighting fixture which receives the infrared signal changes it's addresses at the same time if not pressing this button when setting the address. Choose what fixture is to be changed first, then press this button to change the address. Press it again to the start condition. For example: there are three lighting fixtures, whose addresses are A001, A003 and A007. If the three fixtures receive the infrared signal, the address will be changed if the MODE button is not pressed. If you want to change the address manually, you have to press the MODE button, then choose one of the

fixture that is to be changed (A003, etc.) press SA button to change the address (A010 etc.). This fixture address will be changed to A010.

A/M ALON/MAST : Press this button to the master-slave mode.

SA SET ADDR : Press this button + NUMBER+ ENTER to set the address.



EN ENTER : press this button to confirm.



0 — **9**



Under different function, press the numbers and ENTER to change the address or the dimming.



R press this button for the red color full brightness, Press number+ ENTER to dim the red

color, press  again, the red color will die out.

 press this button to the green color full brightness, press number+ ENTER to dim the green color, press  again, the green color will die out.

 press this button to the blue color full brightness, press number+ ENTER to dim the blue color, press  again, the blue color will die out.

 : press this button to the white color full brightness, press number+ ENTER to dim the white color, press  again, the white color will die out (it depends on whether this function exists in the lighting fixture).

 press this button to the full amber color brightness, press number+ ENTER to dim the white color, press  again, the amber color will die out (it depends on whether this function exists in the lighting fixture).

Notice: press the buttons of the colors you want to mix+ NUMBER button or UP/DOWN+ ENTER to mix the colors.

 + : press this button to increase the value.

 — : press this button to decrease the value.

SAFETY INSTRUCTIONS



CAUTION!

Be careful with your operations. With a dangerous voltage you can Suffer a dangerous electric shock when touching wires!

This device has left the factory in perfect condition. In order to keep this condition and ensure a safe operation, it is absolutely necessary for the user to follow the safety instructions and warning notes written in this user manual.



Important:

Damages caused by the disregard of this user manual are not subject to warranty. The dealer will not accept liability for any resulting defects or problems.

If the device has been exposed to sudden changes in temperature due to environmental changes, do not switch it on immediately. The arising condensation might damage the device. Leave the device switched off until it has reached the room temperature.

This device falls under protection-class I. Therefore it is essential that the device is earthed. The electric connection must be carried out by qualified personnel.

Don't move the device when is set in the operation mode.

Make sure that the available voltage is not higher than stated at the end of this manual.



Make sure the power cord is never crimped or damaged by sharp edges. In this case, the cable replacement must be done by an authorized dealer.

Always disconnect from the mains, when the device is not in use or before cleaning it. Handle the power cord only by the plug. Never pull out the plug by tugging the power cord.

Please don't project the beam onto combustible substances.

Fixtures cannot be installed on combustible substances, keep at more than 50cm distance from the wall for smooth air flow, so there should be no shelter for the fans and the ventilation for heat radiation.

If the external flexible cable or cord of this luminance is damaged, it shall be replaced only by the manufacturer or his service agent or an as well qualified person in order to avoid a hazard.

	<p>CAUTION! Never touch the device during operation! The housing may heat up</p>
	<p>CAUTION! Never look directly into the light source, as sensitive persons may suffer an epileptic shock.</p>

Please be aware that damages caused by manual modifications to the device are not subject to warranty. Keep away from children and non-professionals.

GENERAL GUIDELINES

This device is a lighting effect for professional use on stages, in discotheques, theaters, etc. This fixture can be operated with the max alternating current which is stated in the technical specifications in the last page of this manual, the device was designed for indoor and outdoor use

The lighting effects are not designed for permanent operations. Consistent operational breaks may ensure that the device will properly function for a long time.

Do not shake the device. Avoid brute force when installing or operating the device.

The device shall only be used together with its protective shield.

While choosing the installation-spot, please make sure that the device is not exposed to extreme

heat, moisture or dust. The minimum distance between the projector light-output and the illuminated surface must be more than 0.1 meter.

Operate the device only after having familiarized with its functions. Do not allow operations by not qualified persons to operate the device. Most damages are the result of unprofessional operations.

Please use the original packaging if the device is to be transported.
For safety reasons, please be aware that all modifications on the device are forbidden.

If this device will be operated in any way different from what is described in this manual, the item may be damaged and the guarantee becomes void. Furthermore, any other operation may lead to short-circuits, burns, electric shocks, lamp explosions, crashes, etc.

INSTALLATION INSTRUCTIONS

Mounting the device



CAUTION!

Please consider the EN 60598-2-17 and the other respective national norms during the installation. The installation must only be carried out by a qualified person.

The applicable temperature for the lighting is between $-25^{\circ}\text{C} \sim 45^{\circ}\text{C}$. Do not use the lighting under or above the temperature.

The installation of the effect has to be built and constructed in order to hold 10 times its weight for 1 hour without any harming deformation.

The installation must always be secured with a secondary safety attachment, e.g. an appropriate safety rope.

Never stand directly below the device when mounting, removing or servicing the fixture.

The operator has to make sure that the safety relating and machine technical installations have been approved by an expert before operating the device the first time.

These installations have to be approved by a skilled technician once a year.

Cautions:

The effect should be installed outside areas where people may reach it, walking by or being seated next to it.

Overhead mounting requires an extensive experience, including amongst others calculating working load limits, installation material used and periodic safety inspection of the whole installation material and device. If you lack these qualifications, do not attempt the installation yourself. Improper installation can result in bodily injury.



CAUTION!

The electric connection must only be carried out by a qualified electrician.

Before mounting make sure that the installation area can hold a minimum point load of 10 times the device's weight.

Connect the fixture to the mains with the power plug.

Clamp installation method

Please refer to the picture below:

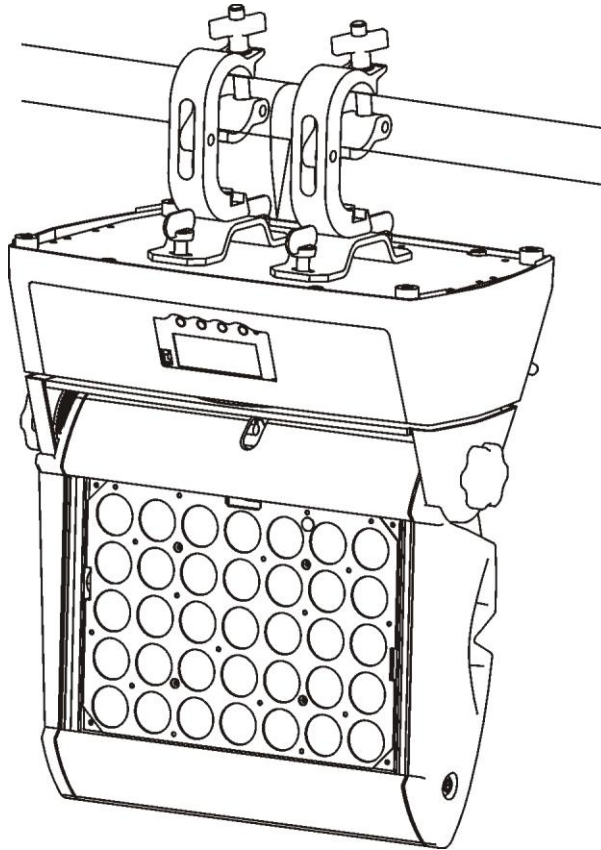

Fix the clamp to the bracket by tightening the M12 screw up on it to the $\Phi 13$ hole which is in the middle of the bracket. Pass the safety rope through the connecting hole located under the side panel, hanging on the fixed bracket or the other fixed station, it can also be floor-mounted (or on any other flat surface) without any fixing, remaining steady no matter what the angle of the head is. Fully operational in any mounting position, hanging upside-down, side mounted, or set on a flat level surface, etc. When clamp mounting; always use and install the supplied safety cable as an added safety measure to prevent any accidental damage in the event of the clamp failure. Make sure that this fixture is kept at least at 0.1m away from any flammable material, such as decoration, etc.

DMX-512 control connection

Connect the provided XLR cable to the female 3-pin XLR output of your controller and the other side to the male 3-pin XLR input of the moving head. You can chain the multiple moving head together through a serial linking. The needed cable should be a two core, screened cable with XLR input and output connectors. Please refer to the diagram below.

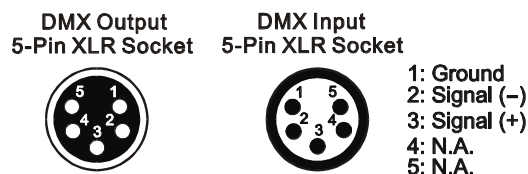

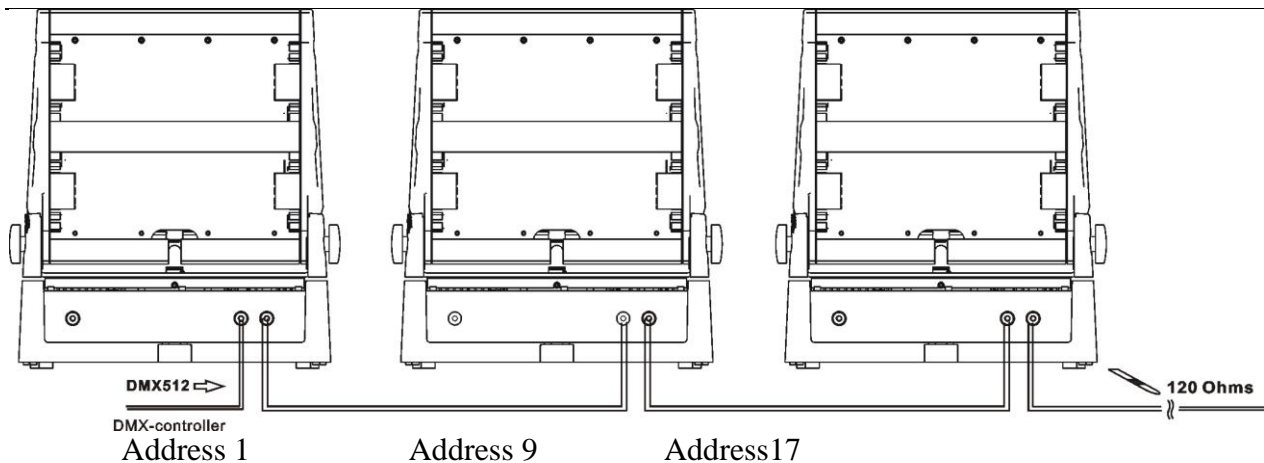

DMX-512 connection with DMX terminator

Thought for installations where the DMX cable has to run a long distance or is in an electrically noisy environment, such as in a discotheque, it is recommended to use a DMX terminator. This helps in preventing corruption of the digital control signal by electrical noise. The DMX terminator is simply an XLR plug with a 120 Ω resistor connected between pins 2 and 3, which is then plugged into the output XLR socket of the last fixture in the chain. Please see illustrations below.

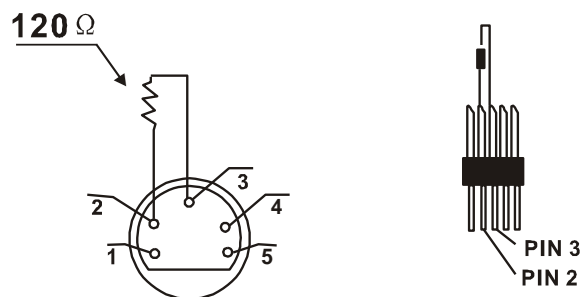

Projector DMX start address selection

All fixtures should be given a DMX starting address when using a DMX signal, so that the correct fixture responds to the correct signals control. This digital starting address is the channel number from which the fixture starts to “listen” to the digital control information sent out from the DMX controller. The allocation of this starting address is achieved by setting the correct number on the display located on the base of the device.

You can set the same starting address for all fixtures or a group of fixtures, or have different addresses for each fixture individually.

If you set the same address, all the units will start to “listen” to the same signal control from the same channel number. In other words, changing the settings of one channel will affect all the fixtures at the same time.

If you set a different address, each unit will start to “listen” to the channel number you have set, based on the quantity of control channels of the unit. This means that changing the settings of one channel will affect only the selected fixture.

In the case of the moving head, which is a 8 channel fixture, you should set the starting address of the first unit to 1, the second unit to 9 (8+ 1), the third to 17 (8+ 9) and so on.

Control Board

Function Mod	Set Dmx Address Value Display Set To Slave Auto Program	A001~AXXX PAN..... Slave1,Slave2,Slave3 Master / Alone		DMX address setting DMX value display Slave setting Auto program
Information	Time Information	Current Time Total Life Hours Last Run Hours Timer Password Clear Last Run	XXXX(Hours) XXXX(Hours) XXXX(Hours) Password=XXX ON/OFF	Power on running time Fixture running time Fixture Last times clear Timer Password 038 Clear Fixture Last time
	Temperature Info	Head Temperature	XXX°C/°F	Temperature in the head
	Software Version	Ver1.0.....		Software version of each IC
Personality	Status Settings	Address via DMX No DMX Status	ON/OFF Close/ Hold /Auto	Add. via DMX Auto run if no DMX
	Display Setting	Shutoff Time Key Lock	02~59m 05m ON/OFF	Display shutoff time Key Lock
	Temperature C/F	Celsius Fahrenheit		Temperature switch between °C/°F
	Manual Hold	ON/OFF		Keep manual control
	Reset Default	ON/OFF		Restore factory set.
Effect Adjust	Manual Control	PAN :	PAN =XXX :	Fine adjustment of the led
	White Balance	Red.....	Red =XXX.....	White balance adjust
Edit Program	Select Programs	Auto Pro Part 1 Auto Pro Part 2 Auto Pro Part 3	Program 1 ~ 10 Program 1 Program 1 ~ 10 Program 2 Program 1 ~ 10 Program 3	Select programs to be run
	Edit Program	Program 1 : Program 10	Program Test Step 01=SCxxx Step 64=SCxxx	(“STEP XX”) Testing program Program in loop Save and exit
	Edit Scenes	Edit Scene 001 ~ Edit Scene 250	Pan,Tilt,..... --Secne Time-- Input By Outside	Pan=xxx..... TIME=xx.xs Save and automatically return manual scenes edit
	Rec.	XX~XX		Automat. scenes rec

	Controller		
--	------------	--	--

Default settings shaded

Function Mode

DMX address setting

With this function, you can adjust the desired DMX-address via the Control Board.

- Select “**Set DMX address**” via encoder.
- Press the encoder, adjust the DMX address by turning the encoder.
- Press the encoder to confirm.
- Press the Mode/Esc- button in order return to the main menu.

Display the DMX 512 value of each channel

With this function you can display the DMX 512 value of each channel. The display automatically shows the channel with a value changing.

Slave setting

With this function, you can define the device as slave.

Auto Program

With this function, you can run the internal program. You can select the desired program under “**Select program**”. You can set the number of steps under “**Edit program**”. You can edit the individual scenes under “**Edit scenes**”. With this function, you can run the individual scenes either automatically, i.e. with the adjusted Step-Time.

Information

Time information

Current Time

With this function, you can display the device temporary running time from the last power on. The display shows “XXXX”, “XXXX” stands for the number of hours. The counter is reset after turning the device off.

Total life Hours

With this function, you can display the device running time. The display shows “XXXX”, “XXXX” stands for the number of hours.

Last Run Hours

With this function, you can display the lamp last running time. The display shows “XXXX”, “XXXX” stands for the number of hours.

Time Password

With this function, you can display the timer password. The time password is 038.

Clear Last Run

With this function, you can clear the fixture last run time. The display shows “ON” or “OFF”. Press “Enter” to confirm.

Temp. Info.

Head Temp

With this function you can display the temperature on the base display board (near CMY-filter) in Celsius.

Software version

With this function, you can display the device software version.

- Select “**Software version**” by turning the encoder.
- Press the encoder, the display shows “**V-X.X**”, “X.X” stands for the version number, e.g. “V-1.0”, “V-2.6”.
- Turn the encoder to read the version of every individual IC.
- Press the Mode/Esc- button in order to return to the main menu.

PERSONALITY

Status Settings

Address via DMX

With this function, you can adjust the desired DMX- address via external controller.

- Select “**Address via DMX**” by turning the encoder.
- Press the encoder, the display shows “ON” or “OFF”.
- Turn the encoder to select “ON” if you wish to enable this function or “OFF” if you don’t.
- Press the encoder to confirm.
- Press the Mode/Esc- button in order to return to the main menu.
- On the controller, set the DMX-value of channel 1 to “7”.
- Set the DMX- value of channel 2 to "7" or "8". When set to "7" you can adjust the starting address between 1 and 255. When set to "8" you can adjust the starting address between 256 and 511.
- Set the DMX- value of channel 3 to the desired starting address. If you want to set the starting address to 57, set channel 1 to "7", channel 2 to "7" and channel 3 to "57". If you want to set the starting address to 420, set channel 1 to "7", channel 2 to "8" and channel 3 to "164" (256+ 164= 420).
- Wait for approx. 20 seconds and the unit will carry out a reset. After that, the new starting address is set.

No DMX Status

With this function, when the drive is not DMX signal, it runs automatism, close, hold and music, the default is hold.

Display Setting

Shut off time

With this function you can shut off the LCD display after 2 to 59 minutes. Turn the encoder in order to select the desired shut off time.

Locked keys the display

With this function you can activate the automatic key-lock function. If this function is activated, the keys will be automatically locked after exiting the edit mode for 15 seconds. Keep the [Mode/ Esc] key pressed for 3seconds if you want to deactivate the key- lock status.

1. Tap the [UP] button until “KEY LOCK” is displayed then tap the [ENTER] button.
2. Press the [UP] button to select “ON” to activate this function, or “OFF” to deactivate this function. Press [ENTER] to confirm.
3. Press [Mode/ Esc] to return to the main menu.

Temperature C/F

With this function, display the temperature in Celsius or Fahrenheit.

Manual Hold

With this function activated the fixture will return to the scene manual set automatically after the re-power on.

1. Tap the [MENU] button until “Manual Hold” is displayed then tap the [ENTER] button.
2. Press the [UP] button and select “ON” to activate this function, or “OFF” to deactivate this function. Press [ENTER] to confirm.
3. Press [MENU c] to return to the main menu.

Reset Default

With this function, you can select restore factory set for ON or OFF, the default is OFF.

Effect Adjust

Manual Control

This function is used to adjust the LEDS more easily. All effects will be erased, the shutter opens and the dimmer intensity will be set to 100%. With the individual functions, you can focus the light on a flat surface (wall) and reform the fine LEDS adjustment.

White balance

White balance setting:

1. Set "Color_Mode" at 220;
2. Adjust red, green and blue leds to achieve target white balance;
3. Set "Internal programs" at 71;
4. Set "Color_Mode" at 255, wait 4 seconds for the target white balance to be stored.

Edit program

Select program

With this function, you can select the program for the Program Run.

Edit program

With this function, you can edit the internal programs.

Edit scenes

With this function, you can edit the scenes of the internal programs.

Auto scenes rec.

The moving head features an integrated DMX- recorder by which you can transmit the programmed scenes from your DMX-controller to the moving head. Adjust the desired scene numbers via the encoder (from– to). When you call up the scenes at your controller, they will automatically be transmitted to the moving head.

Excursion:

A Master unit can send up to 3 different data groups to the Slave units, i.e. a Master unit can start 3 different Slave units, which run 3 different programs. The Master unit sends the 3 program parts in a continuous loop.

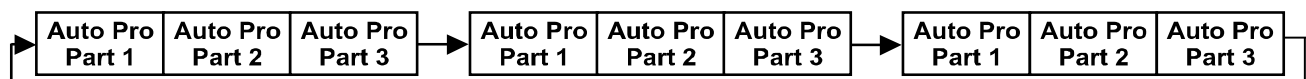

The Slave unit receives data from the Master unit according to the group which the Slave unit was assigned to. If e.g. a Slave unit is set to “Slave 1” in the menu “Set to Slave”, the Master unit

sends “Auto Program Part 1” to the Slave unit. If set to “Slave 2”, the Slave unit receives “Auto Program Part 2”.

To start a Auto Program please proceed as follows:

1. Slave-Setting

- Select “Function Mode” by turning the encoder.
- Press the Enter button to confirm.
- Select “Set to slave” by turning the encoder.
- Press the Enter button to confirm.
- Turn the encoder to select “Slave 1”, “Slave 2” or “Slave 3”.
- Press the Enter button to confirm.
- Press the Mode/ Esc button in order to return to the main menu.

2. Automatic Program Run

- Select “Function Mode” by turning the encoder.
- Press the Enter button to confirm.
- Select “Auto Program” by turning the encoder.
- Press the Enter button to confirm.
- Turn the encoder to select “Master” or “Alone”. The selection "Alone" means Stand Alone-mode and "Master" that the device is defined as master.
- Press the Enter button to confirm.
- Press the Mode/Esc button in order to return to the main menu.

3. Program selection for Auto Pro Part

- Select “Edit program” by turning the encoder.
- Press the Enter button to confirm.
- Select “Select programs” by turning the encoder.
- Press the Enter button to confirm.
- Turn the encoder to select “Auto Pro Part 1”, “Auto Pro Part 2” or “Auto Pro Part 3”, and thus select which Slave program is to be sent. Selection “Part 1” means, that the Slave unit runs the same program as the master units.
- Press the Enter button to confirm.
- Press the Mode/Esc button in order to return to the main menu.

4. Program selection for Edit Program

- Select “Edit program” by turning the encoder.
- Press the Enter button to confirm.
- Select “Edit program” by turning the encoder.
- Press the Enter button to confirm.
- Turn the encoder to select the desired program. With this function you can edit specific scenes into a specific program.
- Press the Enter button to confirm.
- Press the Mode/ Esc button in order to return to the main menu.

5. Automatic Scene Recording

- Select “Edit program” by turning the encoder.
- Press the Enter button to confirm.
- Select “Edit scenes” by turning the encoder.
- Turn the encoder to select the desired scene numbers. You can program a maximum number of 250 scenes.

- Turn the encoder to select the desired scene numbers. You can program a maximum number of 250 scenes.
- Press the Enter button to confirm.
- Press the Mode/ Esc button in order to return to the main menu.

Example:

Program 2 includes scenes: 10, 11, 12, 13

Program 4 includes scenes: 8, 9, 10

Program 6 includes scenes: 12, 13, 14, 15, 16

Auto Pro Part 1 is Program 2;

Auto Pro Part 2 is Program 3;

Auto Pro Part 3 is Program 6

The 3 Slave groups run the Auto Program in certain time segments, as shown in the following picture:

Part 1:

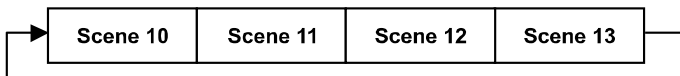

Part 2:

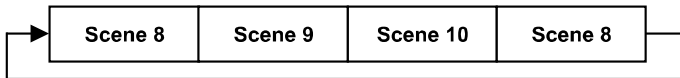

Part 3:

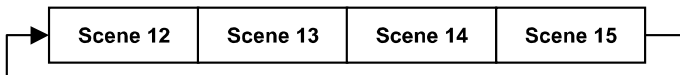

INSTRUCTIONS ON USE:

DMX channel's functions and their values :		
8 Channel	Value	Function
1		<u>Shutter, strobe:</u>
	0-31	Led turn off
	32-63	Led turn on
	64-95	Strobe effect slow to fast
	96-127	Led turn on
	128-159	Pulse-effect in sequences
	160-191	Led turn on
	192-223	Random strobe effect slow to fast
	224-255	Led turn on
2		<u>Dimmer intensity:</u>
	0-255	Intensity 0 to 100%
3		<u>Red LED :</u>
	0-255	Red (0-Black , 255-100% Red)

4		<u>Green LED :</u>
	0-255	Green (0-Black , 255-100% Green)
5		<u>Blue LED :</u>
	0-255	Blue (0-Black , 255-100% Blue)
6		<u>Color Correction :</u>
	0-19	No function
	20-255	20-2700K,255-7200K
7		<u>Internal programs:</u>
	0-10	No function
	11-40	Internal program 1
	41-70	Internal program 2
	71	Store Color_mode enable
	72-100	Internal program 3
	101-130	Internal program 4
	131-160	Internal program 5
	161-190	Internal program 6
	191-220	Internal program 7
221-255	Internal program 8	
8		<u>Color Mode:</u>
	0-63	White balance disabled
	64-189	White balance enabled
	190-250	White balance disabled
	251-255	Store a new white balance
<p>White balance setting:</p> <ol style="list-style-type: none"> 1. Set "Color_Mode" at 220; 2. Adjust red, green and blue leds to achieve target white balance; 3. Set "Internal programs" at 71; 4. Set "Color_Mode" at 255, wait for 4 seconds the target white balance will be stored. 		

CLEANING AND MAINTENANCE

The following points have to be considered during the inspection:

- 1) All the screws for installing the device or parts of it have to be tightly connected and must not be corroded.
- 2) There must not be any deformations in the housing, color lenses, fixation and installation spots (ceiling, suspension, trussing).
- 3) Mechanically moved parts must not show any trace of wearing and must not rotate with unbalances.
- 4) The electric power supply cables must not show any damage, material fatigue or sediments.

Further instructions depending on the installation spot and usage have to be given by a skilled installer and any safety problems have to be solved.



CAUTION!

Disconnect from mains before starting maintenance operation.

In order to have the lights in good condition and extend their life time, we suggest a regular cleaning.

- 1) Clean the inside and outside lens every week to avoid the lights weaknesses due to the dust accumulation.
- 2) Clean the fan every week.
- 3) A detailed electric check by approved electrical engineer every three months, make sure that the circuit contacts are in good condition, prevent the poor contact of circuit from overheating.

We recommend a frequent cleaning of the device. Please use a moist, lint- free cloth. Never use alcohol or solvents.

There are no serviceable parts inside the device except for the lamp. Please refer to the instructions under “Installation instructions”.

Should you need any spare parts, please order genuine parts from your local dealer.

TECHNICAL SPECIFICATIONS

Power supply: AC100-240V~ ,50 Hz /60Hz

Power consumption: 320W

Waterproof grade: IP 65

Net weight: 13.5 KGS

Gross weight: 16. 5KGS

Remarks: errors and omissions for every information given in this manual excepted. All information is subject to change without prior notice.