



TH113 & TH116 A/F/AF

Owner's Guide

Thank you for choosing Aube's non-programmable thermostat. Your new electronic thermostat is equipped with a microprocessor and proportional integral adaptive (PIA) temperature control technology for total comfort. Depending on the selected model, this thermostat has been designed to control:

A: The Ambient temperature (using an electric heating system)

AF: The Ambient temperature with Floor temperature limit (using a floor heating system to heat the room)

F: The Floor temperature (floor heating)

NOTE: This control module must be mounted on a PB112 Series power base.

The thermostat has an On/Standby switch making it possible to put the thermostat in sleep mode when its use is no longer required (e.g. summer).

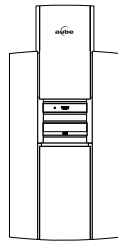

TH116
Public Area

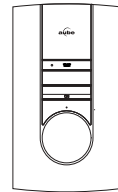

TH113

1 Model Selection (switch)

FOR A AND AF MODELS ONLY

At the rear of the control module is a switch that has been factory-set to the applicable temperature control.

NOTE: The AF model can be used for all temperature control types (A, F and AF).

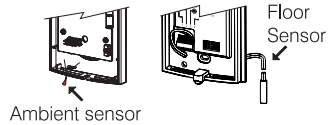

Note: The ambient sensor is not operational when the switch is set to I (up).

Model	Floor sensor	Switch S3	Ambient sensor
F			
AF			
A			

2 Temperature Lock (TH113 only)

At the rear of the control module are two potentiometers. These potentiometers act like a temperature lock. Even when occupants adjust the temperature using the dial on the front/rear of the control module, the potentiometers override the dial and maintain the temperature within the locked-in minimum and maximum range.

- ▶ **A** - ambient temperature
- ▶ **F & AF** - floor temperature limit

Use a flat tip screwdriver to rotate the potentiometers until the notch points to the desired temperature.

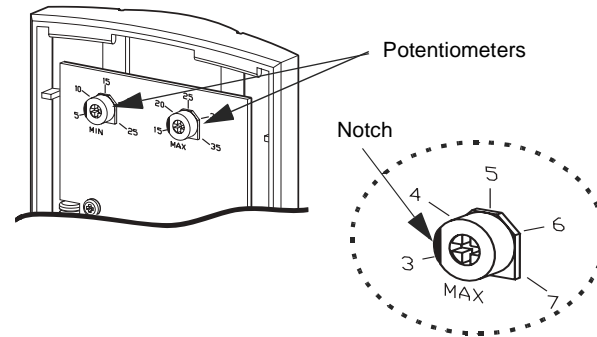

3 Setpoint Definition

Turn the dial to the desired temperature.

TH113: The dial is located on the front of the control module.

TH116: The dial is located on the rear of the control module.

The min. position indicates the minimum temperature setpoint: 45°F (7°C).

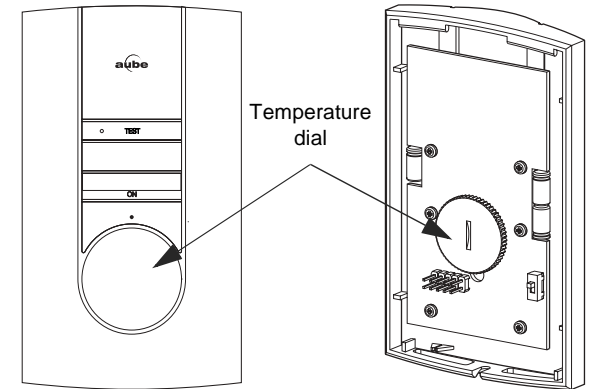

TH113

TH116

4 Control Module Installation

Align the bracket tabs on the control module with the holes located on the power base.

Follow the same procedure for the TH116.

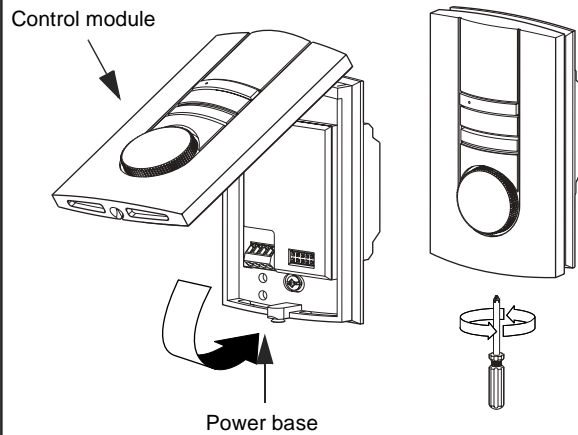

NOTE: Keep the thermostat's air vents clean and free from obstructions.

NOTE: The screw cannot be removed completely.

5 GFCI Test GA & GB power base only

The GFCI monitors the electrical flow for any loss of current; if there is any loss, the thermostat will cut off power to the heating system. We recommend you test the GFCI immediately after installing the control module, and once a month thereafter to ensure it is operating properly. To test:

- Press the TEST button:
 - **Successful:** TEST warning light is ON and power to heating system is cut off.
 - **Unsuccessful:** The TEST warning light is OFF. Cut power to heating system from the main power panel and call customer service.
- When successful, reset thermostat (STANDBY/ON) to power heating system.

NOTE: If the test warning light comes ON during normal operation, cut power to heating system from the main power panel and have an electrician verify the installation.

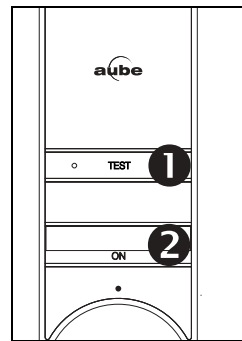

6 Remote Input

The TH113 and TH116 are equipped with a remote input which allows connection of an optional telephone controller (CT240) or any other remote control system. When a command signal is received through this input, the thermostat automatically lowers its setpoint by 3.5°C. The LED lights up to indicate the signal's presence (except for GA and GB models).

Bypass (not available for GA and GB power base): The TEST button can be used to bypass the signal for a 2-hour period. The LED goes off to indicate the bypass.

NOTE: When combined with a GA/GB power base, the TEST button is used only for GFCI testing. The bypass function is not available with these power base models.

Technical Specifications

Models: TH113 and TH116 A / AF / F

Setting range: 45°F, 59°F to 95°F (7°C, 15°C to 35°C)

Potentiometers: minimum: 41°F to 77°F (5°C to 25°C)
maximum: 59°F to 95°F (15°C to 35°C)

Accuracy: ± 0.9°F (0.5°C)

Storage: -4°F to 120°F (-20°C to 50°C)

Warranty

AUBE TECHNOLOGIES INC. ONE (1) YEAR LIMITED WARRANTY
This product is guaranteed against workmanship defects for a one year period following the initial date of purchase. During this period, AUBE Technologies Inc. will repair or replace, at our option and without charge, any defective product which has been used under normal conditions. The warranty does not cover delivery costs and does not apply to products poorly installed or randomly damaged following installation. This warranty cancels and replaces any other manufacturer's express or implied warranty as well as any other company commitment. AUBE Technologies Inc. cannot be held liable for related or random damages following the installation of this product. The defective product as well as the purchase invoice must be returned to the place of purchase or mailed, prepaid and insured, to the following address:

Aube Technologies Inc.
705 Montrichard
Saint-Jean-sur-Richelieu, Quebec, Canada J2X 5K8

If you have any questions concerning the TH113 or the TH116 thermostat, call our technical support team at:

Phone: Montreal area: (450) 358-4600
Canada / U.S.: 1-800-831-AUBE (2823)
Fax: y(450) 358-4650
Email: service@aubetech.com

Monday to Friday from 8:30 AM to 5:00 PM EST.

For more information on our products, visit us at:

www.aubetech.com

MASTER THERMOSTATS	SLAVE UNITS
TH113-A/F/AF (12VDC)	CT230-120GA
TH114-A/F/AF (12VDC)	CT230-120GB
TH115-A/F/AF (12VDC)	CT230-240GA
TH116-A/F/AF (12VDC)	CT230-240GB

1. Introduction

This master and slave unit system is specially designed for large floor heating applications exceeding 15 A.

The master thermostat controls a single or multiple floor heating zones driven by slave units. The master thermostat can control up to 10 slave units.

Each slave unit drives its own zone and is equipped with a GFCI test button and warning light as well as an On/Standby switch to facilitate maintenance on specific zones of the floor installation.

2. Operation

Master Thermostat

The master unit controls the temperature and sends a signal to slave units when heating is required. The floor sensor is connected to the master unit. The master unit is powered by the slave units.

Slave Unit

The slave unit receives the signal sent by the master unit and activates its load.

NOTE: There must be a minimum of one slave unit ON to power the master unit.

3. Installation

Turn off power to the heating system at the main power panel to avoid electrical shock. Installation should be carried out by an electrician.

3.1 Wiring Guidelines

- The wire distance between the master thermostat and slave unit should not exceed 500 ft. (150 m).
- The floor sensor cable should not exceed 200 ft. (60 m).
- A 3-wire 20 AWG cable is recommended.

3.2 Slave Units - Installation and Wiring

The slave units can operate on different voltages (e.g. 5 units @ 120 V and 5 @ 240 V).

- Required parts:** CT230-120GA, -120GB, -240GA or -240GB
- Installation:** On an electrical box
- Location:** Installation near the master thermostat is not required (i.e. can be installed in a utility room).
- Wiring:** The power bases are joined through a daisy chain connection.

- Connect the 120 V or 240 V power base wires to the power (line) and to the load (floor) using solderless connectors for copper wires, and secure the base to the electrical box.
- Affix the wiring sticker (in the CT230 box) to the base.
- Connect the slave power bases together as per FIGURE 1.
- Once installation and wiring is complete, mount the CT230 interface:
 - Align the bracket tabs of the CT230 with the holes located on top of the power base.
 - Secure the CT230 interface using the screw (captive).

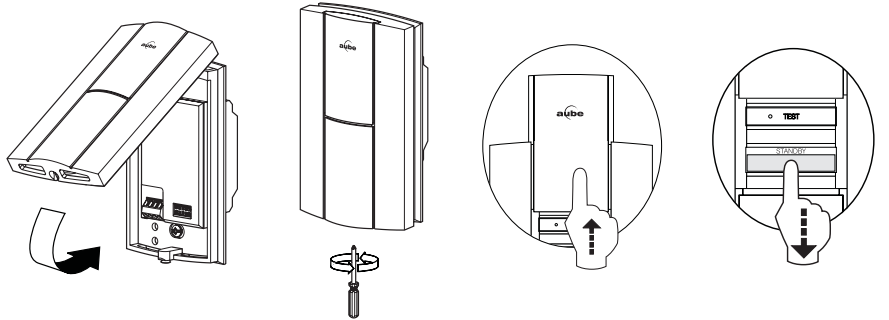
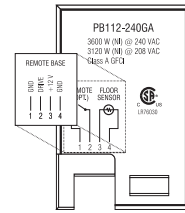
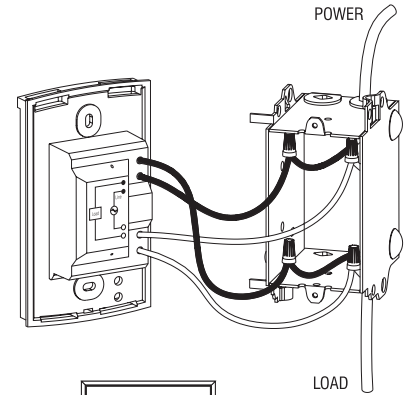

- Switch all slave power bases to STANDBY by sliding the protective door upwards and positioning the switch to STANDBY. Install and connect the master unit (see 3.3).

FIGURE 1
Connections

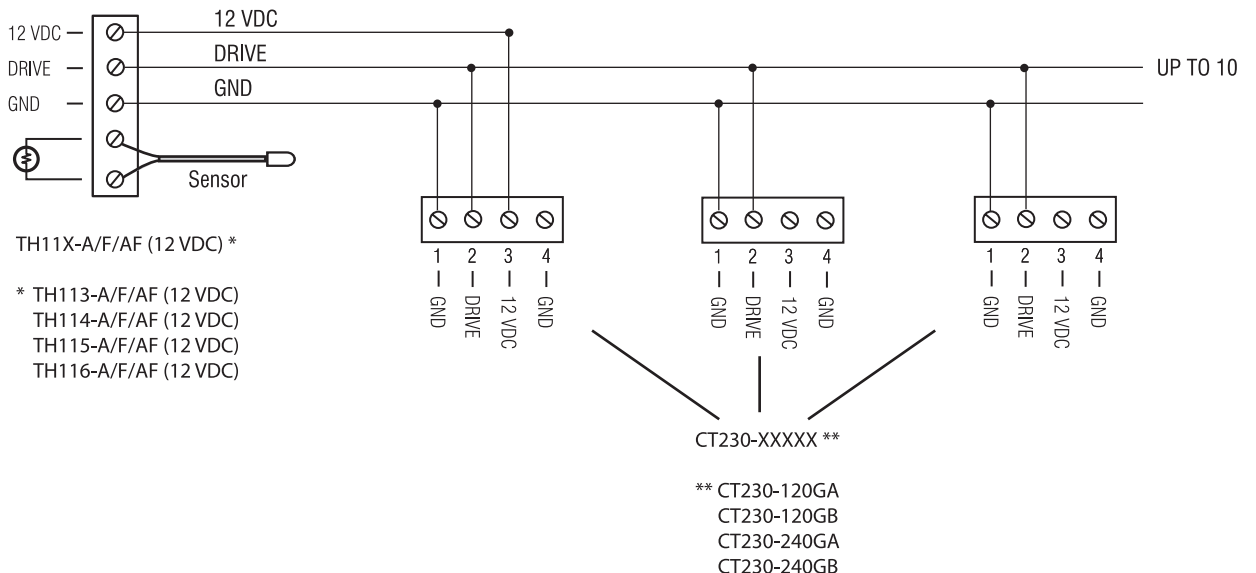

3.3 Master Thermostat - Installation and Wiring

WARNING: Make sure all slave units are in **STANDBY** mode.

- **Required parts:** TH113-A/F/AF (12VDC), TH114-A/F/AF (12VDC), TH115-A/F/AF (12VDC) or TH116-A/F/AF (12VDC)

- **Location:** anywhere easily accessible to users.

Temperature control: AF (ambient with floor limit) / A (ambient)

- Install the master thermostat in the controlled area.
- Choose a location about 5 ft. above the floor in an area where the temperature is stable.
- Avoid locations where there are air drafts (top of staircase, air outlet), dead air spots (behind a door), direct sunlight or concealed chimneys or stove pipes.

Temperature control: F (floor)

- Can be installed anywhere.

- 6 Wire the 12 VDC base to the nearest slave unit.

The floor sensor must be installed in an area where average temperature can be read. The cable must follow the wall down to the floor and must not cross any heater wires or be directly on or adjacent to a heating wire.

For maximum performance, the sensor probe should be centered between the wires in the mat (max. 80°C).

- 7 Push the excess wire into the wall, secure the base using the provided screws and wall anchors, and install the TH11x thermostat onto the base.

- 8 Once the thermostat is installed, return power to heating system and switch all slave units and the master thermostat to ON.

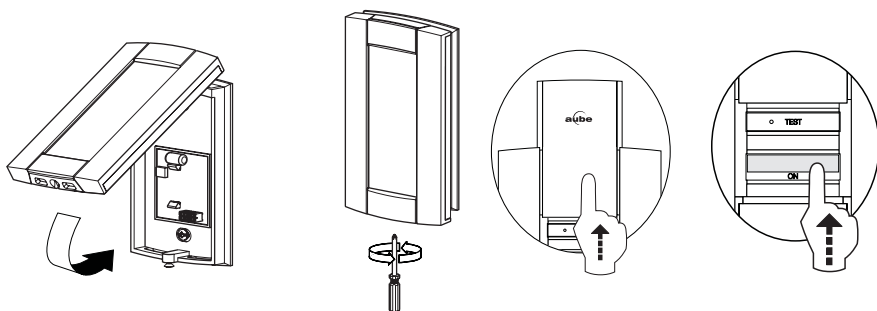

3.4 Slave Units - GFCI Test

We recommend you test the GFCI immediately after installing the thermostat, and once a month thereafter to ensure it is operating properly.

If the test warning light comes ON during normal operation, cut power to heating system from the main power panel and verify the installation.

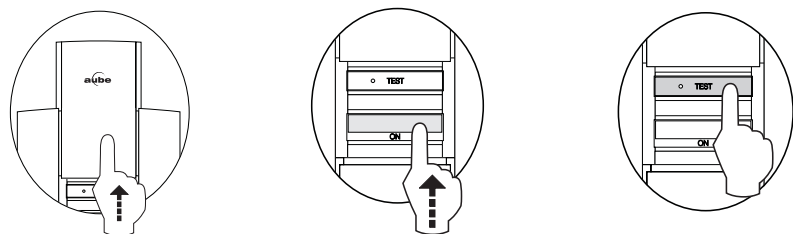

- 1 Slide the protective door upwards and make sure the switch is ON.
- 2 Press TEST.
 - The test is successful if the TEST warning light is ON and power is cut off.
 - If the test fails (first installation test):
 - a. Verify installation
 - b. Check the load wires
 - c. Once you've identified the problem, run the GFCI test again
 - If the test fails (monthly maintenance):
 - a. Cut power to heating system from the main power panel and call customer service
- 3 When the test is successful, reset the slave unit by switching from ON to STANDBY then back to ON.
- 4 Repeat steps 1 to 3 for all slave units.

Technical Specifications

Temperature:

- Operation: 32°F to 122°F (0°C to 50°C)
- Storage: -4°F to 122°F (-20°C to 50°C)

TH113/TH114/TH115/TH116 (A/F/AF-12VDC)

Power supply	12 V from remote unit
Maximum slave units	up to 10 slave units per master thermostat
Wire gauge	20 AWG
Size (H • W • D) BASE	4.63 x 2.7 x 0.61 in. (117.5 x 68.3 x 15 mm)

NOTE: Refer to the TH11x user guide for technical specifications.

CT230-120GA/120GB/240GA/240GB

Supply	
- PB112-120	1800 W @ 120 VAC 60 Hz, 15 A resistive
- PB112-240	3600 W @ 240 VAC 60 Hz, 15 A resistive
GFCI	GA=5 mA / GB=30 mA
Certification	c CSA us
Size (H • W • D) BASE	4.63 x 2.7 x 1.45 in. (117.5 x 68.3 x 37 mm)
Size (H • W • D) INTERFACE	4.67 x 2.74 x 0.67 in. (118.6 x 69.6 x 17 mm)

Service

If you have any questions concerning the installation of the master thermostat or slave units, contact our technical support team at:

Montreal area: (450) 358-4600
 Canada / U.S.: 1-800-831-AUBE (2823)
 Fax: (450) 358-4650
 Email: service@aubetech.com

Monday to Friday from 8:30 AM to 5:00 PM EST.

For more information on our products, visit us at www.aubetech.com

Warranty

AUBE TECHNOLOGIES INC.
 ONE (1) YEAR LIMITED WARRANTY

This product is guaranteed against workmanship defects for a one year period following the initial date of purchase. During this period, AUBE Technologies Inc. will repair or replace, at our option and without charge, any defective product which has been used under normal conditions.

The warranty does not cover delivery costs and does not apply to products poorly installed or randomly damaged following installation. This warranty cancels and replaces any other manufacturer's express or implied warranty as well as any other company commitment.

AUBE Technologies Inc. cannot be held liable for related or random damages following the installation of this product. The defective product as well as the purchase invoice must be returned to the place of purchase or mailed, prepaid and insured, to the following address:

Aube Technologies Inc.
 705 Montrichard
 Saint-Jean-sur-Richelieu, Quebec,
 Canada J2X 5K8