

PROGRAMMABLE POWER SUPPLY

————— 3644A-TYPE —————

Operating Manual

ARRAY ELECTRONIC CO., LTD

COPYRIGHT © ARRAY 2002

Programmable Power supply

3644A user's manual

Chapter 2 Operation.....	7
2.1 General operation	7
2.2 Function introduction.....	7
2.2.1. Main functions.....	7
2.2.2 Sub-functions.....	7
2.3 The operation of the function.....	7
2.3.1 V-set.....	8
2.3.2 I-set.....	9
2.3.3 Switch ON/OFF power output.....	9
2.3.4 Store data function.....	10
2.3.5 Recall data function.....	11
2.3.6 The function of the Menu.....	12
2.3.6.1 Set up the maximum voltage output value (0~36V).....	12
2.3.6.2 Set up the key sound.....	13
2.3.6.3 Set up the communication.....	13
2.3.6.4 Set up communication address (0~254).....	13
2.3.6.5 Set up locking key board.....	13
2.3.6.6 Set up constant power output.....	14
2.3.6.7 Set up save option.....	14
2.3.6.8 Set up the output after powering.....	14
2.3.6.9 Clear all the saved data.....	14
2.3.6.10 Exit function.....	14
Chapter 3 System Installation.....	15
3.1 System Installation.....	15
3.2 System Start.....	17
3.3 System Uninstallation.....	17
Chapter 4 The Function Introduction.....	18
4.1 The Definition of the Power Supply.....	18
4.2 The COM Port and Lower Machine (Power Supply) Address Set.....	19
4.3 Run the Communication.....	20
4.4 Stop the Communication.....	20
4.5 Select POWER.....	21
4.6 Select PC to POWER Control Instructions.....	21
4.7 Set the Voltage Range.....	21
4.8 Set the Max Current.....	21
4.9 Users' Manage.....	22
4.10 Query the Report.....	23
4.11 Explanation of the Interface Indicating Components.....	23
4.12 The State Bar.....	24
4.13 Help.....	24
4.14 Logout User.....	24
CONTENTS	
Caution.....	2
Safety notes.....	2
Chapter 1 General Introduction	3
1.1 General Introduction.....	3
1.2 Specification.....	3
1.3 Features	4
1.4 Dimension and Structure.....	4
1.4.1 Dimension.....	4
1.4.2 Structure.....	5
1.4.2.1 Front view	5
1.4.2.2 Back view.....	6

CAUTION

Before switching on the DC Power supply, the protective earth terminal of this instrument must be connected to the protective conductor of the AC line power cord. The AC line plug shall be inserted only in a socket outlet provided with a negated by the use of an extension cord (or power cable) with a protective grounding conductor.

SAFETY NOTES

The following general safety precautions must be observed during all phases of operation, service, and repair of this instrument. Failure to comply with these precautions or with specific warnings elsewhere in this manual violates safety standards of design, manufacture, and intended use of the instrument. The Manufacturer assumes no liability for the customer's failure to comply with these requirements.

Ground the Instrument

This product is provided with a protective earth terminal. To minimize shock hazard, the instrument chassis and cabinet must be connected to an electrical ground. The instrument must be connected to the AC power supply mains through a three-conductor power cable, with the third wire firmly connected to an electrical ground (safety ground) at the power outlet. For instruments designed to be hard-wired to the AC power lines (supply mains), connect the protective earth terminal to a protective conductor before any other connection is made. Any interruption of the protective (grounding) conductor or disconnection of the protective earth terminal will cause a potential shock hazard that could result in personal injury. If the instrument is to be energized via an external autotransformer for voltage reduction, be certain that the autotransformer common terminal is connected to the neutral (earthed pole) of the AC power lines (supply mains).

Keep Away From Live Circuits

Operating personnel must not remove instrument covers. Component replacement and internal adjustments must be made by qualified service personnel. Do not components with power cable connected.

Under certain conditions, dangerous voltages may exist even with the power cable removed. To avoid injuries, always disconnect power, discharge circuits and remove external voltage sources before touching components.

Do Not Substitute Parts or Modify Instrument

Because of the danger of introduction additional hazards, do not install substitute parts or perform any unauthorized modification to the instrument. Return the instrument to a qualified dealer for service and repair to ensure that safety features are maintained.

Chapter 1 General Introduction

1.1 General Introduction

3644A-Type Programmable DC Power Supply is designed and manufactured by ARRAY Electronic Co., Ltd. This instrument is a kind of mini-size DC programmable power supply with nice appearance. Also it is equipped with back-light LCD display, number keypad and rotary code switch which let it much easier to use. Voltage, current and power can all be displayed on the LCD or computer and tableau is distinct and clear. It can be operated at constant current mode, constant voltage mode, constant power mode. Also it can be set maximum limit for current output and maximum limit for power. It is an essential instrument for scientific research, education, service and so on institutions.

1.2 Specification

Type	3644A	3645A	3646A
Output (Line)	1	1	1
Output voltage	0~18V	0~36V	0~65V
Constant current	0~6A	0~3A	0~1.5A
Voltage resolution	1mV at 0~3.999V 5mV at 4~18V	1mV at 0~3.999V 10mV at 4~36V	1mV at 0~3.999V 2.0mV at 4~65v
Current resolution	<=1mA		
Line Regulation for Voltage	0-3.999V 4-36V	0.01%+3mV 0.02%+10mV	
Line Regulation for Current	0.02%+8mA		
Load Regulation for Voltage	0.02% 10mV		
Load Regulation for Current	0.02%+8mA		
Ripple	Vrms <=2mVrms		
Reaction Time of the Output Program Set	Up (50/90%) 10ms Down (90/50%) 30ms		
Communication Cable	RS232/RS485 *		
Monitor software	Free software VC++ / VB / DELPHI / LABVIEW / COM Cable		
Memory	10 points EEPROM		
Protective mode	Over voltage /over current /over power		
Power voltage	AC 110/220 available (60/50HZ)		
Situation	0~50%RH 80% RH		
Weight	5.5Kg		
Size	WxHxD 250mmX212mmX88mm		
Accessories	Software, users manual, AC power cable, handlebars		
Purchase Option Parts	Communication cable for RS232 Communication cable for RS485 Mounting rack		

1.3 Features

1. LCD display with back light.
2. Number keypad.
3. High resolution at 1mv.
4. Protection for over or lower voltage.
5. Protection for over or lower current.
6. Adjustable voltage and constant voltage output.
7. Adjustable current and constant current output.
8. Can be set for maximum current protection.
9. Can be set by number key or rotary code switch.
10. Power shut-down memory function
11. Monitored by PC software.
12. Mini-size and removable light weight.
13. Can be used as series connect and parallel connect.

1.4 Dimension and Structure

1.4.1 Dimension

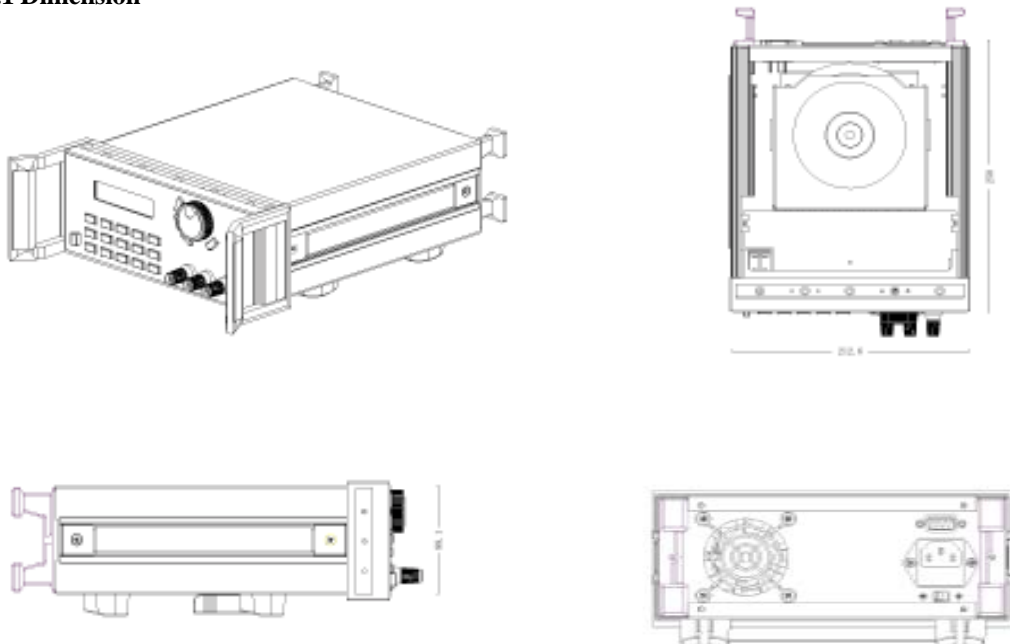

Fig 1 Dimension of 3645A Programmable DC power supply

1.4.2 Structure

1.4.2.1 Front view

Front panel is for users to operate. Please see the following picture for details.

- 1. LCD Display
- 2. Number Keyboard
- 3. Rotary Code Switch
- 4. Output Terminal

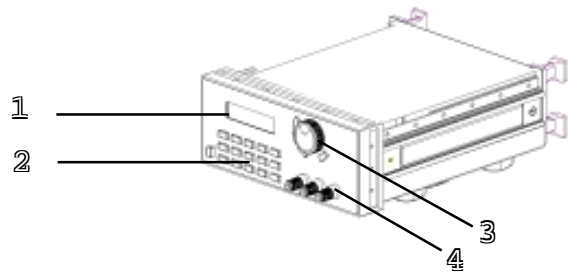

Fig2. Front view of 3645 DC power supply

1. LCD display



Fig3. LCD Display of 3645 power supply

The Left-upper Conner:

The set voltage value.
(Flashing voltage means the low-voltage.)

The Left-bottom Conner:

The output power value.
(Flashing power value means the over power.)

The Right-upper Conner:

The output current value.

The Right-bottom Conner:

The state value.
ON(OFF):
represents the output state of the power supply .
PC(KEY) :
represents the operation of the keypad or the computer.
OH:
iepresents the over-hot state

2. Arrangement of the Keyboard

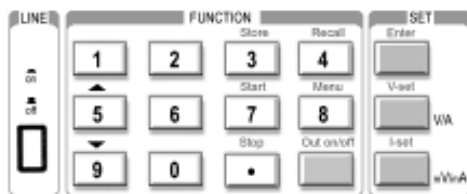

Fig4. Key board of 3645 DC power supply

In common state, the keyboard will execute the prompting functions of the black words. And in special mode, it will change into the functions of the blue color words.

0~9: The number keys

Store: Save the current setting value

Recall: Read the saved setting value

Menu: The menu operation key

OUT ON/OFF: Open/Close the output

Enter: The confirmation key

V-set: The output voltage value set

I-set: The max output current set

▲ : The up moving key

▼ : The down moving key

V/A: Setting the voltage represent V
Setting the current represent A

mV/ mA : Setting the voltage represent mV
Setting the current represent mA

3. Rotary code switch and function keys



Left Operation: The left moving key

Right Operation: The right moving key

ESC: Can be used to exit any working state

OK: Confirmation key

Rotary SW: The rotation key

Fig5. Rotary and function keys

1.4.2.2 Back view

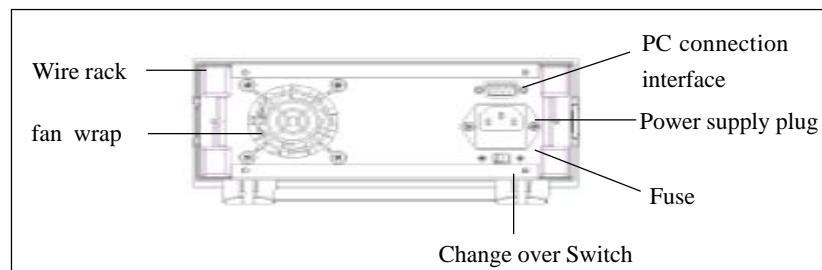

Fig 6 Back view

The fuse can be changed easily by using a small screw driver. Please use a fuse within the range of 2~2.5A.

Chapter 2 Operation

2.1 General operation

1. Connect the power supply with PC

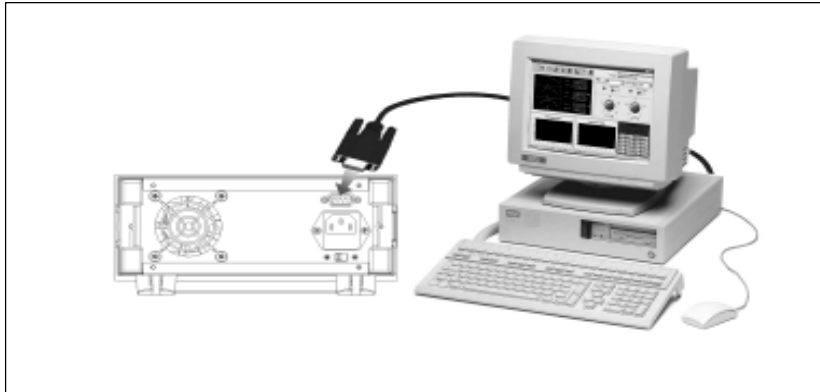

Fig 7 Connect the power supply with PC

2.2 Function introduction

2.2.1. Main functions

1. Set up a constant voltage from 0 to 36V
2. Set up a constant current or maximum protection current from 0 to 3A
3. Switch ON/OFF the power supply output
4. Store 10 sets of data which had been set up
5. Recall the stored data

2.2.2 Sub-functions

1. Set up the output voltage limit
2. Turn ON/OFF the sound of key
3. Set up the Baud Rate
4. Set up the communication address
5. Lock/unlock the keyboard
6. Set the maximum power
7. Save the last set voltage value
8. Set up the output state after powering
9. Clear all the saved data

2.3 The operation of the function

We know that there are 5 main functions and 9 sub-functions of this power supply, the following will describe how to operate all of the functions. Before any operation, please connect the power, and switch the power on, then the power indicator will be lighted.

2.3.1 V-set (set up a constant voltage from 0 to 36V)

Set up a constant DC voltage output is the first main function of programmable DC power supply, 3645A power supply provides two methods to set up the constant DC voltage output by using the number keyboard and the rotary button. Please see the following operation procedure.

Procedure	Operation details	LCD display
Step 1	Press "V-set"	ENTER PASSWORD
Step 2	Enter the password (Or jump to step 4 if the keyboard is unlocked)	ENTER PASSWORD
Step 3	Press "Enter" button (it will return to step 2 if your password is wrong for reentering)	ENTER PASSWORD ****
Step 4	Press "V-set" .Set the voltage voltage to 24.00V by using the number key or the rotary code switch.Then pyess "V/A" to confirm the set	SET VOLT= 0.000V NEW=
Step 5	Press "mV/mA" button to change the voltage unit into mV, it will return to step 4 for reentering if the current voltage exceed the high limited voltage value	SET VOLT= 24.00V NEW= 18
It will exit the setting up voltage operation at any procedure by press ESC button		

For example, how to set up the output voltage at 24.3V

1. To set up by using number keyboard

- Step1. Press "V-set" button,
- Step2. Enter the password by using the number keyboard (if the keyboard is unlocked, please do step4),
- Step3. Press Enter button (if the password is wrong, please do step2 for reentering),
- Step4. Press "2", "4", "." and "3" button to enter the voltage value,
- Step5. Press "V/A" button to confirm the voltage value.

2. To set up by using Rotary SW

(1) If the key board is unlocked by password, directly rotate the "Rotary SW" button, and the voltage will be continually changed from the previews value according the rotation. At the beginning, the cursor will be shown on the last number of the value which is indicated on the LCD, you can move the cursor to the first number, second number etc by using "◀" and "▶" buttons, and then rotate to change each number, and let it stay at 24.3 V, then confirm the value by pressing "V/A" button.

(2) If the keyboard is locked by password

- Step1. Press "V-set" button,
- Step2. Enter the password by using the number keyboard,
- Step3. Press Enter button (if the password is wrong, please do step2 for reentering),
- Step4. Rotate the Rotary SW button to change the value, the operation is as the same as item(1)
- Step5. Press "V/A" button to confirm the voltage value.

2.3.2 I-set (set up a constant current or a maximum current from 0 to 3A)

3645A power supply can be set up for a constant current or a maximum current from 0 to 3A, and there are two special application for users when he set up the I-set, please see the following example.

Conditions: voltage=24V, load $R=12\ \Omega$, then $V/R=2\text{ A}$, it represents that the power supply provide the load with 2A current. If

1)Set up the current $I = 2.50\text{A}$, then the current should be displayed on the screen as 2.00A.

2)Set up the current $I = 1.00\text{A}$, then the current should be displayed on the screen as 1.00A. It means that the power supply provides load 1.00A current.

Set up current procedure is as following:

Procedure	Operation details	LCD display
Step 1	Press "I-set"	ENTER PASSWORD
Step 2	Enter the password (Or jump to step 4 if the keyboard is unlocked)	ENTER PASSWORD
Step 3	Press "Enter" button (it will return to step 2 if your password is wrong for reentering)	ENTER PASSWORD ****
Step 4	Press "I-set" . Set up a constant current or a maximum current by using number keyboard or the rotary code switch. Then press "V/A" to confirm the set.	SET CURR=0mA NEW=3
Step 5	Press "mV/mA" button to change the voltage unit into mA, it will return to step 4 for reentering if the current value exceeds the high limited value of 3A	SET CURR=0mA NEW= 15.0
It will exit the setting up current operation at any procedure by press ESC button		

2.3.3 Switch ON/OFF power output

The output of 3645A type power supply should be off when it is powered, users can change the output status by using ON/OFF button. The button is a turn over button, when the original output is ON, press the button, then the output will be changed to OFF status, when the original output is OFF, press the button, then the output will be changed to ON status.

2.3.4 Store data function

To users, this is a good function for ease using. If you want to use a constant voltage and current as 24V and 2A, or 12V and 2.3A etc every day, you just need to set up the data for the first time, and then store the data in the power supply, and then recall it when you need the data again. It can store 10 sets of data at most.

The stored contents include 1) Voltage value; 2) Current value; 3) Maximum voltage; 4) Locked/unlocked key board; 5) Maximum power; 6) Baud rate; 7) Communication address.

The store operation always be done after setting up V-set, I-set etc, the operation is as following:

Procedure	The operation Methods	LCD display
Step 1	Press "Store" button	ENTER PASSWORD
Step 2	Enter the password (Or jump to step 4 if the keyboard is unlocked)	ENTER PASSWORD
Step 3	Press "Enter" button (it will return to step 2 if your password is wrong for reentering)	ENTER PASSWORD 1234
Step 4	Enter the set value for store number(from 1 to 10) by using the number key or rotate the rotary button to change the set value number for store	SAVE 1
Step 5	Press "Store" button to confirm the set value, if the number is out of the range from 1 to 10, it will return to Step 2 for reenter	SAVE *
It will exit the store operation at any procedure by press ESC button		

For example, set up the voltage=15V, current=2A, Maximum output voltage=18V, key board locked, Maximum output power=25W, Baud rate=9600, communication address=05, after done the setup, users can store all the above setup as a set of data, such as the 01 or 02 etc set date.

2.3.5 Recall data function

In the last paragraph, we know that we can store 10 sets of data of the power supply in the memory. Also you can recall any one set data from the stored data. It means that you needn't to set up again for the usually requirement, and it bring your much ease to use. Users can recall one set of the date from the stored date sets, including set up of 1) Voltage value; 2) Current value; 3) Maximum voltage; 4) Locked/unlocked key board; 5) Maximum power ; 6) Baud rate; 7) Communication address.

The recall operation is as following

Procedure	The operation Methods	LCD display
Step 1	Press "Recall" button	CALL 1
Step 2	Enter the password (Or jump to step 4 if the keyboard is unlocked)	ENTER PASSWORD
Step 3	Press "Enter" button (it will return to step 2 if your password is wrong for reentering)	ENTER PASSWORD 1234
Step 4	Enter the number of the set data which you want to recall (from 1 to 10) by using the number key or rotate the rotary button to change the number you want recall	CALL 1
Step 5	Press "Recall" button to confirm , if the number is out of the range from 1 to 10, it will retune to Step 2 for reenter	CALL *
It will exit the Recall operation at any procedure by press ESC button		

2.3.6 The function of the Menu

3645A power supply provides a Menu operation for some special functions. The operation and function are as following.

Procedure	The operation Methods	LCD display
Step 1	Press "Menu" button	MAX OUT VOLTAGE KEY SOUND SET
Step 2	Enter the password (Or jump to step 4 if the keyboard is unlocked)	ENTER PASSWORD
Step 3	Press "Enter" button (it will return to step 2 if your password is wrong for reentering)	ENTER PASSWORD 1234
Step 4	The LCD display the menu functions one by one, user an use the UP and DOWN button to change the selecting each function, Press "Enter" button to execute the selected function	MAX OUT VOLTAGE KEY SOUND SET COMMUNICATION SET ADDRESS SET KEY LOCK MAX SET POWER SAVE OPTIPN OUT OPTIPN CLEAR SAVE DATA EXIT
It will exit the Menu operation at any procedure by press ESC button		

The menu operation includes MAX OUT VOLTAGE, KEY SOUND SET, COMMUNICATION SET, ADDRESS SET, KEY LOCK, MAX OUT POWER, and Save set function. We will descript the details as following.

2.3.6.1 Set up the maximum voltage output value (0~36V)

When you select the MAX POWER SET function, the LCD will display as:

MAX VOLT = 24 V NEW=

You can set the voltage value by using the number keyboard or rotating the ROTARY button. Then confirm the value by pressing "Enter" button.

2.3.6.2 Set up the key sound

When you select the KEY SOUND SET function, the LCD will display as:

KEY SOUND ON KEY SOUND OFF

Users can select KEY SOUND ON or KEY SOUND OFF by using UP and DOWN key button. KEY SOUND ON represent the sound of keys will be on , and KEY SOUND OFF represent the sound of keys will be off.

2.3.6.3 Set up the communication

This function is for monitoring the output data of the power supply by using a computer.

When you select COMMUNICATION SET function, the LCD will display as:

```
BUAD RATE=4800
BUAD RATE=9600
BUAD RATE=19200
BUAD RATE=38400
```

Users can change the communication setup by using UP and DOWN keys or rotating the ROTARY button, and confirm the value by pressing "Enter" button.

BUAD RATE 4800 represent BUAD rate=4800bps

BUAD RATE 9600 represent BUAD rate=9600bps

BUAD RATE 19200 represent BUAD rate=19200bps

BUAD RATE 38400 represent BUAD rate=38400bps

2.3.6.4 Set up communication address (0~254)

This communication address function is for monitoring multi-power supply system. In the system, one computer can monitor 255 power supplies at the most by the connecting RS232 and 485 bus. So we should give each power supply an address.

When you select ADDRESS SET function, the LCD will display as:

```
SET ADDRESS =12
NEW=
```

Users can change the communication address value by using number keyboard or rotating the ROTARY button, and confirm the value by pressing "Enter" button. The range of the address value is from 0 to 254.

2.3.6.5 Set up locking key board

After you locked the keyboard, you must enter the correct password to unlock it, then you can use the number keys and the ROTARY button. This function is for the safety of the using of power supply.

When you select the KEY LOCK function, the LCD will display as:

```
ENTER PASSWORD
```

Users can enter 4 numbers or letters as the password by pressing the number button or by using ROTARY button to ◀ and ▶ keys to change the number or ASCII number which will be your password, and confirm the password by pressing "Enter" button.

The default password : 1556

2.3.6.6 Set up constant power output (the range is from 0 to 108 W)

When you select the MAX POWER function, the LCD will display as:

```
MAX POWER=56 W
NEW=
```

Users can change the power value by using number keyboard or rotating the ROTARY button, and confirm the value by pressing “Enter” button. The range of the power value is from 0 to 108W.

2.3.6.7 Set up SAVE OPTION

This function is for saving the last set up of the voltage output. It will save much time of users when the users will need the same voltage value. It will display the same voltage value when the power supply is powered on for every time.

When you select the SAVE OPTION function, the LCD will display as:

```
SAVE VOLTAGE
DON T SAVE VOLT
```

Users can change the selection by using UP and DOWN keys or rotating the ROTARY button, and confirm the selection by pressing “Enter” button. To select SAVE VOLTAGE means to save the last set up voltage, to select DON T SAVE VOLT means not to save the last set up voltage value.

2.3.6.8 Set up the output after powering

```
OUT OPTION
CLEAR SAVE DATA
```

This function is to set the output state of the power supply after its powering . Select “OUT OPTION” and press “OK” the two options “FIRST OUT ON” and “FIRST OUT OFF” will be shown for selection by using “←” and “→”. Selecting “FIRST OUT ON” means the output being ON after powering . Selecting “FIRST OUT OFF” means the output being OFF after powering .

2.3.6.9 Clear all the saved data

```
CLEAR SAVE DATA
EXIT
```

This function is to delete the saved data ,Users may delete any set of the 10 sets voltage .

2.3.6.10 Exit function

When the EXIT function is selected, you will exit the Menu operation.

Chapter 3 System Installation

3.1 System Installation

3.1.1 Put the disk into the CDROM drive. Then the system will run automatically and the initial diagram as in Fig. 3-1 will be displayed.



Fig.3-1 The Installation Initial Interface

3.1.2 Then it will enter the interface as in Fig. 3-2. Press “NEXT” to continue.



Fig. 3-2 The Installation Interface 2

3.1.3 In Fig. 1-3, there is some explanation to some products' introduction. Read it and press “YES” to continue, otherwise there will be no way to install.

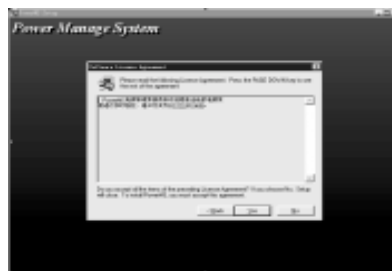

Fig. 3-3 The Installation Interface 3

3.1.4 In Fig. 3-4, click “BROWSE” to select installation directory path. The default directory path is “C:\Program Files\Array\PowerMS”

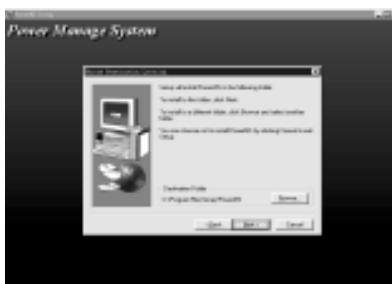

Fig. 3-4 The installation Interface 4 The Installation Directory Path Set

3.1.5 In Fig. 3-5, users may select the installation type. Generally, select “TYPICAL” and click “NEXT” to continue.

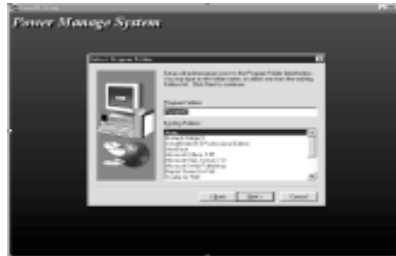

Fig. 3-5 The Installation Interface 5

3.1.6 In Fig. 3-6, enter the file folder's name and the default name is “POWERMS”. Generally it is not needed to enter and it is just need to click “NEXT”.



Fig. 3-6 The Installation Interface 6

3.1.7 Click “NEXT” and the installation system will enter the files' copying state. Please wait patiently for the end of the files' copying. Then the PowerMS system installation is finishing.



Fig. 3-7 The Installation Interface 7 The Files' Copying

3.2. System Start

3.2.1 In Fig. 3-8, select the file folder of “Start | Program | Array”. And then click the “PowerMS” in the menu.



Fig. 3-8 The System Start Interface

3.2.2 Enter the initial interface as shown in Fig. 3-9.

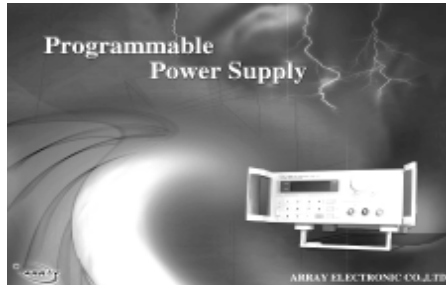

Fig. 3-9 The System Start Diagram

3.2.3 Wait for the end of the system initialization and then it will enter the main interface as shown in Fig. 3-10.

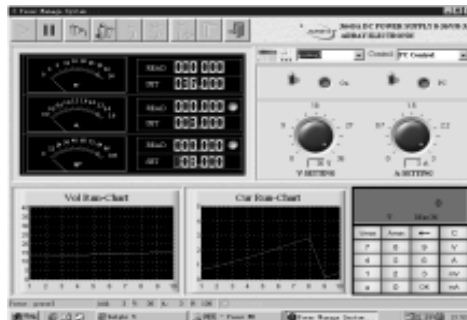

Fig. 3-10 The PowerMS Main Interface

Explanation:

1. Every time the PowerMS system is started, it will automatically in the minimized state. And at this time the icon  is in the state bar on the desk. Click the right key of the mouse on the icon, the menu as shown in Fig. 3-11 will be displayed.



Fig. 3-11

“Show”: Show the interface.

“Hide”: Hide the interface.

“Start Communicate”: Start the communication.

“Stop Communicate”: Stop the communication.

“About PMS”: Show the help contents.

“Exit System”: Close the system.

3.3 System Uninstallation

It is only need to select “ Uninstall PowerMS” in the program file folder. And it must be done after the closing of the system otherwise there will be no way to uninstall.

Chapter 4 The Function Introduction

4.1 The Definition of the Power Supply

Select the function item  and then the interface as shown in Fig. 4-1 will be displayed.

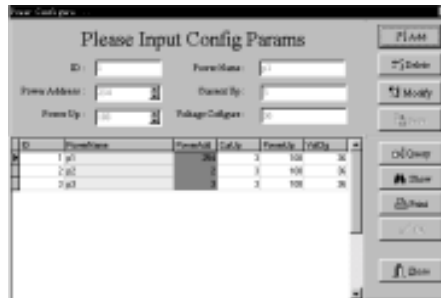

Fig. 4-1 The Power Definition Interface

Add: Select “Add” in the function items and then input the contents of each item. After the set of the input, it is just needed to select “Save” to save it.

Delete: Select the POWER record to be deleted in the table and then select “Delete”. Finally select “Save” and it will be OK.

Modify: Select the POWER record to be modified in the table and then select “Modify” to modify it. After the modification, select “Save” and it will be OK.

Query: Select “Query” and then wait for the name of the power supply to be queried.

Show: Select “Show” and it will show all the records.

Print: Select “Print” and it will print all the current records.

Parameter Explanation

Parameter	Explanation	Range	Remarks
Power Name	Name Of the Power Supply		Must be Input
Current Up	The Max Current	0~3A	Must be Input
Power Up	The Max Power	0~108W	Must be Input
Voltage Configure	The Max Voltage	1~36V	Must be Input
Configure			
ID	The ID Number		No Consideration

Notes: When selecting the “Add” function item to add POWER, the name and address of the POWER cannot be repeated. After entering all the information, click “OK” and the dialogue frame as shown in Fig. 4-2 will be displayed. In Fig.4-3, select “YES” and the system will close and restart.

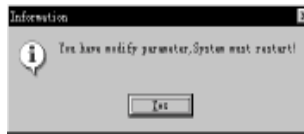

Fig. 4-2 System Prompt the restart

4.2 The COM Port and Lower Machine (Power Supply) Address Set

Login in the identity of "Manager" and then select the quick icon after the system restarts. The dialogue frame as shown in Fig.4-3 will be displayed.

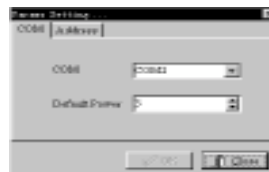

Fig. 4-3 COM Port and address set

In Fig. 4-3, select the page key "COM" and select the COM port from the pull-down table. If the COM port does not exist, the system will prompt the diagram as shown in Fig. 4-4. And the "OK" button and the page key "ADDRESS" are out of work. And vice versa. (And users must be in the identity of the "Manager" otherwise the "ADDRESS" cannot be used.

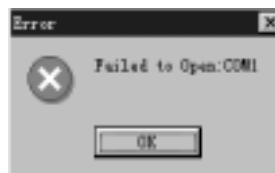

Fig. 4-4 COM Port Failurely Opening Dialogue Frame

Set Default POWER Address:

The system will automatically be in the networking state after the start according to the default COM port and the default POWER. It is just needed to enter the address in the "Default POWER" bar.

Set POWER Address:

Login in the identity of the "Manager" and select the existing COM port. Then the "ADDRESS" page key will be available.

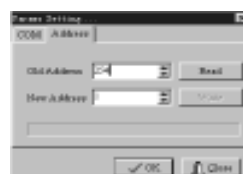

Fig. 4-5 POWER Address Set

In Fig. 4-5, enter the default address (245) of the lower machine and then click “READ”. If testing successfully, the “NEW ADDRESS” and “WRITE” functions will be available. If testing failure, then the new address of the power cannot be set and the prompting diagram as shown in Fig. 4-6 will be displayed. This time the communication cable must be checked.



Fig. 4-6 Communication Failure

Explanation: For the first time installation each POWER must be deployed with but one address so as to communicate rightly. Set the parameter and select “OK” and it will enter into the common communication. The default COM port is COM1 and the default POWER address is 1.

4.3 Run the Communication

After the COM port and ADDRESS set, select the button  and the system will start the communication. If the communication is normal, the prompting information as shown in Fig. 4-7 will be displayed. And if the communication is failure, the prompting information as shown in Fig. 4-8 will be displayed.



Fig. 4-7 Normal Communication



Fig. 4-8 Failure Communication

4.4 Stop the Communication

Select the button  and the system will stop the communication.

4.5 Select POWER

In Fig. 4-9, select the POWER name from the listing frame and it will be OK.



Fig. 4-9 Selecting the POWER

4.6 Select PC to POWER Control Instructions

1.) Methods 1

As in Fig. 4-11, there are four control instructions in total.

CLOSE POWER : Close the power output

OPEN POWER : Open the power output

PC CONTROL : controlled by PC

POWER SELF : Control by power



Fig. 4-10-1 Select the Control Instruction

Explanation: The system defaulting control instruction is the PC CONTROL state. And when the system is closed or the POWER is switching, the system will automatically set to POWER SELF state.

2.) Methods 2



Fig. 4-10-2 Selecting Control Instruction

4.7 Set the Voltage Range

There are two methods to set the voltage range: one is by using the rotary button (1~36) and the other is by using the keyboard (0.004~36.000). If you want to set accurately, please use the keyboard. In general state, you can use the rotary button.



Fig. 4-11 Using the Rotary Button



Fig. 4-12 Using the Keyboard

1) Using the rotary button: Move the mouse to the icon and then rotate the button.

2) Using the keyboard: Select the “V” button, enter the data and then select the “ENTER” button.

4.8 Set the Max Current

There are two methods to set the voltage range: one is by using the rotary button (1~36) and the other is by using the keyboard (0.004~36.000). If you want to set accurately, please use the keyboard. In general state, you can use the rotary button.



Fig. 4-13



Fig. 4-14

- 1) Using the rotary button: Move the mouse to the icon  and then rotate the button.
- 2) Using the keyboard: Select the “A” button, enter the data and then select the “ENTER” button.

Explanation: User to do this set must have the authority above the “General”.

4.9 Query the Report

Select the button  and the diagram as shown in Fig. 4-15 will be displayed.

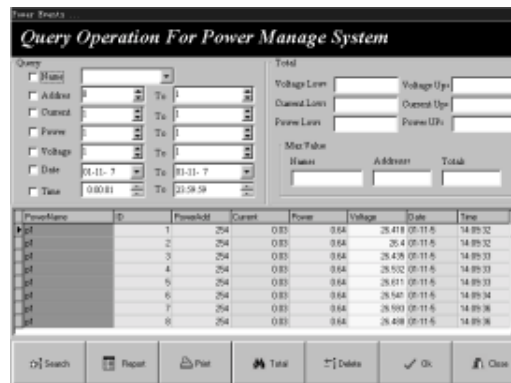

Fig. 4-15 Query the Report

- 1.) Set the Query Conditions: Set the parameters in the “Query” frame.
- 2.) Query: After setting the conditions, select “SEARCH” button and all the records agreed with the conditions will be listed.
- 3.) Set the Report: Select “REPORT” and it will be OK.
- 4.) Print the Report: Select “PRINT” and it will be OK.
- 5.) Query Totally: Select “TOTAL” and it will be OK. The date range must be selected and the other conditions cannot be selected. Its main function is to analyze several POWER so as to list the POWER that overflow the most data. The overflowing data includes the voltage overflowing, the current overflowing and the power overflowing.
- 6.) Delete the History Record: Select “DELETE” and the diagram as shown in Fig. 4-24 will be displayed. If you confirm to delete, select “YES” and it will be OK.



Fig. 4-16 Delete the History Data

Explanation: The date range condition must be set.

7.) Close: Select "CLOSE" and return to the upper-interface.

4.10 Explanation of the Interface Indicating Components

1.) Instrument Part

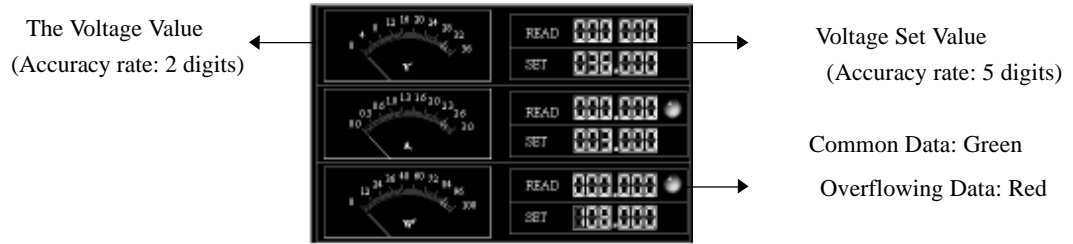
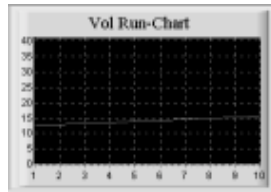

Fig. 4-17 Instrument Indication

Common Date and Overflowing Data are both in the normal communication state.

2.) Running Curve: Indicates the data acquired at the nearest 10 ports.



The Voltage Running Diagram

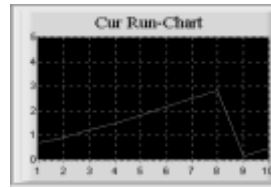

The Current Running Diagram

3.) Keyboard Explanation



Fig. 4-18
Keyboard Explanation

- Number Keys: 0-9 “.”: the point key
- “C”: the clearing key “←”: the backspace key
- “V”: the voltage setting key (Unit: V 0~36.000)
- “A”: the current setting key (Unit: A 0~3.000)
- “mV”: the voltage setting key (Unit: mV 0~36000)
- “mA”: the current setting key (Unit: mA 0~3000)
- “Vmax”: input the max voltage value (36V)
- “Amax”: input the max current value (3A)
- “OK”: the confirmation key

Panel Part:

- V: presents the current voltage set state (Unit: V).
- Max 36: presents that the max set voltage value is 36.
- 0: the current set value

4.11 The State Bar



Power: p3: presents the current selected POWER.

Add: 3: presents the POWER address.
 V: 36: presents the defined voltage max value.
 A: 3: presents the defined current max value.
 W: 108: presents the defined power max value.
 Sending: presents the operation state.

4.12 Help



Click the icon  and the help diagram as shown in Fig. 3-26 will be displayed.







Fig. 4-19 Help Interface

It main includes the information about the Http and the e-mail addresses of Array Electron Company and so on.

Select the icon  and the system will automatically be in the lowest limit of authority. User must login again for the operation. When leaving, the user must carry out the canceling operation, especially the manager.

4.13 Power Supply State Indication

- | | |
|------------------------------------|---|
| 1. Overloading current indication: |  |
| Blue presents normal. | Red presents overloading. |
| 2. Overloading power indication: |  |
| Blue presents normal. | Red presents overloading. |
| 3. Power supply ON/OFF state |  |
| Blue presents OFF. | Red presents ON. |
| 4. Power supply control type: |  |
| Blue presents CONROL SELF. | Red presents PC CONTROL. |

4.14 Exit the System

Select the icon . To do this, you must login first, otherwise the system cannot be closed.