

# PowerTel 50 Alarm plus

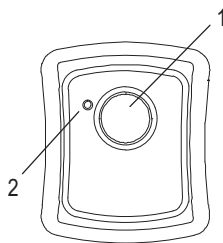

# **At a glance**

**Please open this page for “At a glance” guide to your telephone.**

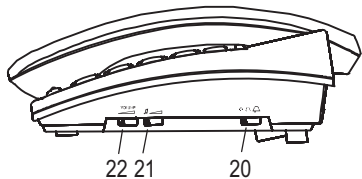
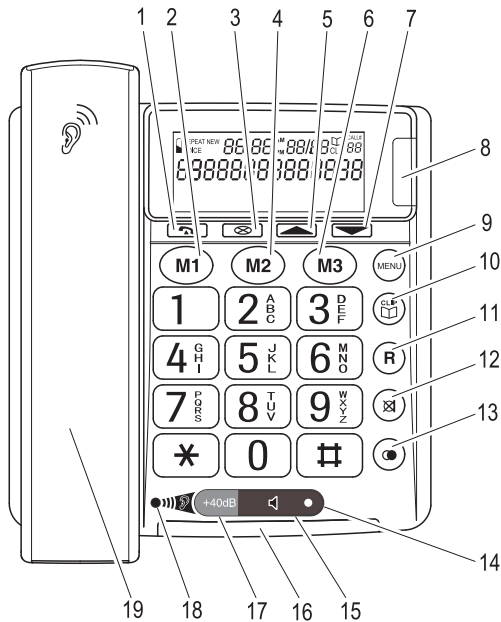

## Telephone

- 1 Call back button
- 2 One-touch dialling button M1 (emergency call number 1)
- 3 Delete
- 4 One-touch dialling button M2 (emergency call number 2)
- 5 Scroll upwards
- 6 One-touch dialling button M3 (emergency call number 3)
- 7 Scroll downwards
- 8 LED, emergency call unit / New call indication (see page 26)
- 9 Menu button
- 10 Calls list (CLIP) / Phone book
- 11 R button
- 12 Microphone muting button
- 13 Redial button
- 14 LED, handsfree mode
- 15 Handsfree mode button
- 16 LED, telephone is ringing
- 17 Receiver +40 dB boost button

**Helpline UK 0844 800 6503**

(See page 43 for costs and hours of operation)

- 18 Volume boost on LED
- 19 Control knob, receiver volume  
(hidden under premium handset)
- 20 "Ringing volume" slide control
- 21 "Tone" slide control
- 22 "Handsfree volume" slide control

### **Emergency call unit**

- 1 Start automatic emergency call
- 2 LED, battery level indicator

<b>Getting started.....</b>	<b>6</b>
Check box contents .....	6
Connecting the telephone.....	7
Wall mounting.....	9
Display icons .....	10
Setting date an time .....	12
Setting the language .....	12
 <b>Making and receiving calls .....</b>	 <b>14</b>
Dialling a telephone number .....	14
Ending a call.....	14
Taking a call.....	15
Activating/deactivating handsfree mode.....	15
Boost the handset earpiece volume .....	16
Setting the handset receiver volume.....	16
Ringer volume.....	16
Setting the handset receiver tone .....	16
Setting the handsfree volume .....	17

Muting the microphone .....	17
Dialling a telephone number using the redial function .....	17
Calling back missed calls .....	17
Dialling a telephone number from the phone book.....	18
One-touch dialling / Emergency call .....	19
Chain dialling .....	20
<b>Phone settings .....</b>	<b>22</b>
Phone book .....	22
Calls list.....	26
Emergency Call Unit.....	29
Settings.....	35
Special use .....	37
<b>Appendix.....</b>	<b>40</b>
Safety notes .....	40
Intended use.....	40
Installation location .....	40
Power supply .....	41

Hearing aid compatibility .....41

Disposal .....42

Help and support / Troubleshooting guide .....43

Maintenance .....44

Guarantee .....44

Declaration of conformity .....45

**Index.....48**

**Notes.....50**





# Getting started

**Helpline UK 0844 800 6503**

(See page 43 for costs and hours of operation)

## Getting started

**Important: please make sure you've read the safety information on page 40 before you set up your phone system.**

**Important: Your phone can produce very high sound when Boost is switched on. Please take care if the handset is used by others.**

## Check box contents

You should have:

- 1 corded phone base
- 1 power adapter plug
- 1 handset
- 1 coiled cord for handset
- 1 Emergency call unit, can be worn on neckband or wristband (splash-proof)
- 1 telephone line connector cable
- 4 Batteries, AA 1.5 V
- 1 Battery type 23 A, 12 V already installed in the emergency call unit
- 1 wall-mounting bracket
- 1 user guide

**Important:**

- Use only the power adapter supplied with your telephone.
- Use only the telephone cable supplied with your telephone otherwise your phone may not work.

## Connecting the telephone

For using **all features** e. g. **Hands-Free** and **Amplification** it is **essential** that the telephone is **powered by the power supply and the batteries**.

1. Insert the batteries in the open battery compartment.

Only use batteries of the type AA 1.5 V.

Pay attention to the correct polarity.

Close the battery compartment cover.

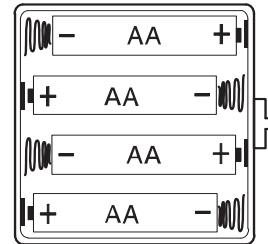

Pay attention that the telephone is not connected to the telephone line socket and/or mains power connection when the batteries are being inserted or replaced.

2. Connect the telephone as illustrated in the diagram. Only use the telephone cable supplied because the equipment may not function if another telephone cable is used.

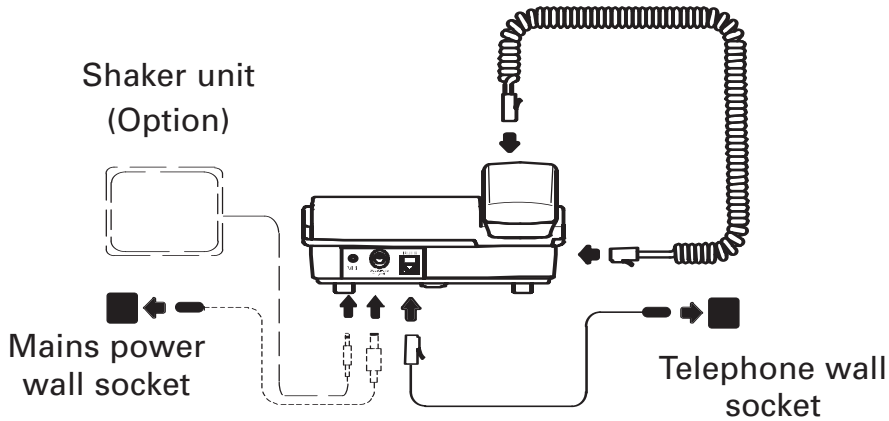

**In order to use an approved shaker unit, connect the shaker unit plug to the "Vibrat." socket in the telephone. No other work is necessary. The shaker unit is ready to operate immediately after connection. The shaker unit does not belong to the material supplied.**

## Wall mounting

The telephone can also be installed on a wall. You require two screws in order to fix the telephone on a wall.

Feed the guide tabs (1) on the wall-mounting bracket (2) in the slots (3) on the rear side of the telephone. Slide the wall bracket (2) 10 mm upwards until it audibly snaps into place.

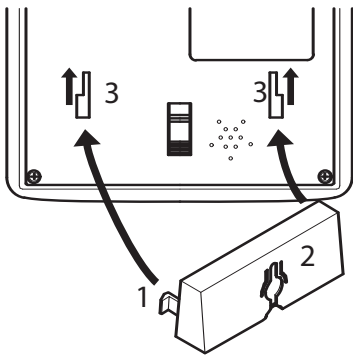

**Warning: Ensure that there are no cables or pipes etc. under the surface of the wall where you want to drill the holes.**

Drill two holes whose distance apart corresponds to the bracket to be used, insert the screws and allow them to project 5 mm from the wall. Position the telephone on the bracket, fit the screws in the slots and slide the telephone downwards a little.

Turn the receiver hook (4) in the receiver cradle 180° so that the receiver can be hooked in.

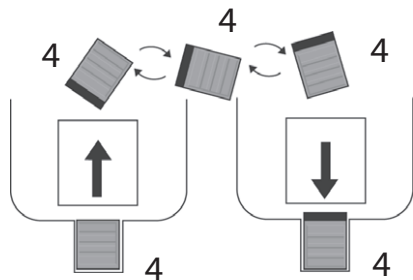

## Display icons



Replace the batteries.

14:45

Display of the time.

11/06

















Display of the date.











The phone book is open.

<b>CLIP</b>	The calls list is open.
<b>NEW</b>	The entry in the calls list is new.
<b>REPEAT</b>	Indicates a repeat call.
<b><sup>CALLS</sup> 01</b>	Position number in the call list.
<b>TOTAL: XX</b>	There are XX entries in the call list.
<b>NEW: XX</b>	There are XX new entries in the call list.
<b>VOICE</b>	Flashing: Recording mode is active (see pages 24, 30). On: A name has been recorded for this phone book entry.
<b>+</b>	An emergency call number (M1, M2 or M3) has been dialled (see page 31).

## Setting date and time

- Press .
- Select **TIME/DATE** using  /  and press .
- Adjust the hours using  /  and press .
- Adjust the minutes using  /  and press .
- Adjust the month using  /  and press .
- Adjust the day using  /  and press .
- Press  to exit the menu.

## Setting the language

- Press .
- Select **LANGUAGE** using  /  and press .
- Select a language using  /  and press .
- Press  to exit the menu.

**For more settings please refer to the chapter “Settings” on page 35**



# **Making and receiving calls**



# Making and receiving calls

## Dialling a telephone number

To start a call you have the following options:

- lift the handset and enter the phone number.
- enter the phone number and lift the handset.

or alternatively

- enter the phone number and press  or .

Handsfree mode will be activated and the phone number will be dialled (for handsfree mode power supply/batteries necessary).

- During a call you can see the call time on the display.

## Ending a call

For ending a call you can:

- replace the handset.

or alternatively

- press  if the call was made in handsfree mode (the red LED within the handsfree button is on).

## Taking a call

Lift the handset or press .

## Activating/deactivating handsfree mode

During a call you are making using the handset you can switch to handsfree mode to switch on the loudspeaker (power supply/batteries necessary).



Press  and then replace the handset.

If you want to continue the call using the handset simply lift the handset.

### **Please note:**

- **During handsfree mode your speech is transmitted via the microphone on the base. Speak at a distance of not more than 0.5 meters facing the front of the unit.**
- **High background noise levels can prevent satisfactory operation.**

## Boost the handset earpiece volume

You can boost the handset earpiece volume to +40 dB (power supply/batteries necessary). Press . The "On" LED   is on.

**Caution: This telephone is capable of producing very high volume levels when the amplifier is switched on and the volume control is set to maximum. Extreme caution should be taken if the handset is to be shared between users with normal hearing and those with hearing impairment.**

## Setting the handset receiver volume

You can adjust the handset receiver volume using the control (19) / (refer to "At a glance").

## Ringer volume

You can adjust the ringer volume using the control (20) (refer to "At a glance").

## Setting the handset receiver tone

You can adjust the handset receiver tone using the control (21) if the Boost function (60 dB) is on (refer to "At a glance").

## Setting the handsfree volume

You can adjust the handsfree volume using the control (22) (refer to “At a glance”).

## Muting the microphone

The microphone in the handset can be activated and deactivated during a telephone conversation.

Press and hold  : Switch the microphone off (muting)

Release  : Switch the microphone on





## Dialling a telephone number using the redial function

Your telephone stores the last phone number dialled.



- Lift the handset or press  and then press .

## Calling back missed calls

The telephone stores the numbers of missed calls in a calls list. For further information please refer to the chapter „Calls list“ on page 26.





- Lift the handset or press , then select the desired entry using   
and  and press .

or alternatively





- select the desired entry using  and  and press . The  
loudspeaker will be switched on. If you want to proceed the call using the  
handset, just lift it up. The loudspeaker will be switched off.

## Dialling a telephone number from the phone book

For how to create and store phonebook entries please refer to the chapter  
“Phone book” on page 22.

- Lift the handset or press .
- Press , select the desired entry using  and  and press  
.

or





- Press  , select the desired entry using  and  and press  . The loudspeaker will be switched on. If you want to proceed the call using the handset, just lift it up. The loudspeaker will be switched off.

## One-touch dialling / Emergency call

The one-touch dialling / emergency call buttons M1, M2 or M3 can be used for normal quick dial numbers or as a memory location for automatic emergency call dialling. For how to store one-touch / emergency numbers please refer to the chapter “Storing emergency call / quick dial numbers” on page 31.

- Lift the handset or press .
- Press briefly the one-touch memory button  ,  or .





or

- Press briefly the one-touch memory button  ,  or .
- Lift the handset or press .

**Note: The telephone numbers assigned to the one-touch dialling buttons can not be deleted. When storing new numbers, the existing entries are overwritten.**

## Chain dialling

The function is used in more complex telephone services, e.g. for telephone banking, call-by-call or calling card procedures. Several numbers stored in the phone book can be dialled successively when a connection has already been made. It is also possible to combine numbers for transfer from the phone book with numbers entered manually. Numbers stored in the phone book can be chained and transmitted as required.

- Whilst in a call press , select the desired entry using  /  and press .



# Phone settings

**Helpline UK 0844 800 6503**  
(See page 43 for costs and hours of operation)

# Phone settings

## Phone book

30 phone numbers can be stored in the phone book together with the associated names.

- Always enter the area access code with the phone numbers so that the telephone can also assign incoming local calls to a phone book entry.
- When the memory capacity of the phone book is used up, the message **MEMORY FULL** appears when an attempt is made to store another number. To create space, an existing entry must first be deleted.
- The phone book entries are arranged alphabetically. To skip to the required phone book entry directly, enter the first letter of the corresponding entry.

### Entering a name









The digit keys are also labelled with letters for the entry of the respective letters. Pressing the respective key the necessary number of times enables capital letters and digits to be entered.

Enter a space by pressing  .

Delete a character by pressing  .



To enter the same letter twice, press the button to enter the letter. Wait until the cursor skips one place forward. Enter the letter again.





## Creating phone book entries

- Press .
- Select **STORE NUMBER** using  and  and press .
- Enter the telephone number and press .
- Enter the name and press .
- If you want to store a spoken name (which is spoken, when you call up the phonebook entry or a call from this person arrives) for the entry immediately, press and hold down .
- Speak the name for the entry and release  again, if you have finished.

**Note: You can also add a spoken name to a telephonebook entry later (see below).**









## Editing entries in the phone book

- Press  and select an entry using  and .

- Press and hold  for approx. 3 s and confirm **EDIT?** by pressing .
- Enter the new telephone number if necessary and confirm with .
- Enter the new name if necessary and confirm with .

### Record names to phonebook entries

A name can be recorded for each phone number stored in the phone book. When you subsequently select an entry in the phone book, the recording you made for it is played and you can hear the entry you have selected.

- Press .
- Select **NAME RECORDING** using  and  and press .
- Then select an entry using  and .
- Press and hold  to start recording and release  for ending.







**Note: If the key is not released, recording is automatically stopped after 3 seconds.**

- Press  to exit the menu.



## Deleting recordings

- Press .
- Select NAME RECORDING using  and  and press .
- Then select an entry using  and .
- Press  during playback to delete the recording.

## Deleting a single entry from the phone book

- Press  and select an entry using  and .
- Press . The display shows DELETE?.
- Press and hold  for approx. 4 s. Entry is deleted.
- To abort the deleting procedure press .

## Delete all entries from the phone book

- Press  and select an entry using  and .

- Press and hold  for approx. 4 s.  
The display shows DELETE ALL?.
- Press and hold  for approx. 4 s. again.
- To abort the deleting procedure press  .

## Calls list

**Note: The caller number display function, essential for the calls list, is a supplementary service offered by telephone network providers. Contact your network provider for further information.**





If this function is available with your telephone line, the number of the caller and the name, if an entry in the telephone book exists, appears in the display or is spoken when the phone rings. If the caller has suppressed transmission of his phone number or it is otherwise unavailable, a corresponding message appears in the display. The phone number is not displayed and, as a result, is not stored in the calls list.

The idle display shows, how many entries are in the calls list and how many of them are NEW (not yet seen). A total of 64 call numbers can be stored in the calls list. The flashing red LED indicates new calls in the calls list. **This LED will flash as long as there are still new (not read) calls in the calls list.** To stop flashing press  repeatedly.

### Displaying phone numbers in the calls list





- Select an entry using  and .

### Storing numbers from the calls list in the phone book

- Select an entry using  and .
- Press and hold  for approx. 3 seconds and confirm COPY TO MEMORY with .
- The phone number is stored in the phone book without a name being assigned. Then enter a name for the phone number (see “Editing entries in the phonebook”).

**Note: When the number in the phone book is stored together with a name, the name entered also appears in the calls list.**

## Deleting phone numbers individually

- Select an entry using  and .
- Press . The display shows DELETE?.
- Press and hold  for approx. 4 s. The entry is deleted.

## Deleting all entries

- Select an entry using  and .
- Press and hold  for approx. 4 s.  
The display shows DELETE ALL?.
- Press and hold  for approx. 4 s. again.

**Note: Before deleting the phone numbers, check that the entries have been viewed.**



## Emergency Call Unit

The emergency call unit can be used to dial an emergency services exchange or persons for assistance.







**Note: There are several appropriate emergency service call numbers available, such as the Red Cross, St. John's Ambulance Brigade, etc. In some countries emergency calls are not free of charge. The unit can also be used for private emergency calls within the family, for example.**

### Outgoing alert message

There is a default outgoing alert message recorded on the telephone. You can replace this message with one of your own. After activating an automatic emergency call, the phone numbers assigned to buttons **M1**, **M2** and **M3** are called automatically. The alert message is played repeatedly until your emergency call is acknowledged by the person receiving it through pressing the “0” key. For this reason, you must end your own alert message clearly telling the receiving party to “...take this emergency call by pressing the 0 key!”.

**Note: When recording your message, make sure that the person called recognises your name in the emergency call. Inform them clearly that this is an emergency call and that you need help.**

## Recording an outgoing alert message

- Press .
- Select RECORD MESSAGE using  /  and press .
- Press and hold down  when you speak your message.
- Release  to end recording.

## Playing the outgoing alert message









- Press .
- Select CHECK MESSAGE using  /  and press .

## Deleting the outgoing alert message

- Press .
- Select CHECK MESSAGE using  /  and press .
- Press  during playback. The message will be deleted.

## Storing emergency call / quick dial numbers

The quick dial buttons M1, M2 and M3 can be used for normal quick dial numbers or as memory locations for automatic emergency call dialling.

- Press .
- Select **STORE NUMBER** using  /  and press .
- Enter the telephone number (max. 22 digits) and press .
- Select a quick dial button ,  or  and press .

**Note: The phone numbers assigned to the quick dial keys cannot be deleted. When storing new numbers, the existing entries are overwritten.**

## Automatic emergency call

The automatic emergency call can be initiated by pressing and hold the buttons **M1**, **M2** or **M3** on the telephone or the button on the emergency call unit. If no phone number has been assigned to **M1**, **M2** or **M3**, no phone number is dialled but a loud warning signal is issued from the telephone.

**Note: Pay attention that the emergency call unit is within range of the telephone.  
The batteries in the emergency call unit should always be full.**

### Automatic emergency calls via the telephone

- Press and hold down **M1** , **M2** or **M3** for approx. 5 seconds to start the automatic emergency call function.
- Press **◀** or again **M1** , **M2** or **M3** for approx. 5 seconds to end the automatic emergency call function.

### Automatic emergency calls via the emergency call unit

1. Press and hold the button (1) on the emergency call unit for 5 seconds to start the automatic emergency call function.
2. Halten Sie erneut die Taste am Notrufgeber für 5 Sekunden gedrückt, um den automatischen Notruf zu beenden.

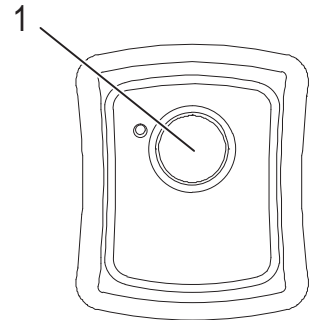

## Starting/Ending the automatic emergency call

The phone behaves as follows on starting the automatic emergency call:

1. The emergency phone loudspeaker is switched on. An acoustic “emergency call active” signal is sounded for 15 sec.
2. You can then hear the dialling tone and the phone numbers assigned to the **M1**, **M2** and **M3** buttons are automatically dialled, in succession, at intervals of approx. 60 seconds. The outgoing alert message is played in a continuous cycle.
3. The person answering the call immediately hears this alert message. The person taking the call stops the outgoing alert message by pressing “0”. You can then converse for 3 minutes. Handsfree mode remains active on the phone making the emergency call during this time.
4. When the 3 minutes have elapsed, the call is disconnected. An attempt begins again to dial the phone numbers assigned to buttons **M1**, **M2** and **M3** as described above.
5. If the call is disconnected or the receiver is placed on-hook before the 3 minutes have elapsed, an attempt is made to dial the emergency numbers. The emergency procedure won't be stop unless 3 numbers have been dialled out or press the button on the emergency call unit again or press **M1**, **M2** or **M3** for 5 seconds.

**Note: To end an emergency call, press the button on the emergency call unit again or press M1, M2 or M3 for 5 seconds.**

### Testing the emergency call unit battery

1. Press and hold the button (1) on the emergency call unit briefly. The LED (2) lights up.
2. If the LED (2) no longer lights up when the button is pressed and held, replace the battery.

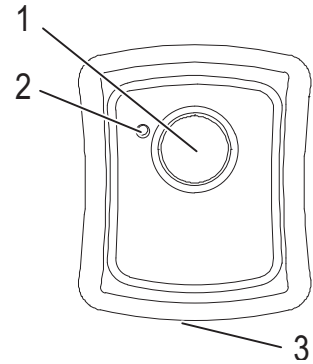



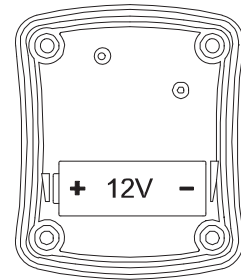

### Replacing the battery



1. Remove the screw on the rear side of the emergency call unit using a small, crosstip screwdriver.
2. Insert the tip of a small screwdriver in the notch (3) and open the housing.
3. Replace the battery. Only use batteries of the same type. Pay attention to correct polarity.
4. Close the housing.



## Settings

You can perform various settings on your phone.

- Press  to open the menu.
- Scroll using  and  to the desired entry and press  to open the relevant sub-menu.

LCD CONTRAST (1-5)      Modify settings using  and  or press  to keep the current setting.

TIME/DATE                      see page 12.

STORE NUMBER                see page 23, 31.

NAME RECORDING              see page 24.

RECORD MESSAGE              see page 30.

CHECK MESSAGE                see page 30.

## LANGUAGE

see page 12. The outgoing messages and display texts on the telephone are available in 4 languages.

## FLASH

In most situations the flash time of 100 ms should be selected. In some cases, e. g. when connecting the phone to a PABX, it may be necessary to switch to 300 ms. For further information please refer to the user guide of the PABX.

## RINGER TONE (1-3)

Modify settings using  and  or press  to keep the current setting.

## VOICE

When a button is pressed, a voice accompanies the action. This voice can be activated and deactivated, as required.

- Press  to exit the menu.



## Special use

### Use on a private branch exchange

If your phone's on an exchange (e.g. you need to dial 9 to get an outside line), you can transfer calls and use call back by using the  button.

You'll need to check your private exchange manual to find out which timing to use for your exchange.

### Insert a dialling pause

If you have to dial a number for an outside line and it takes a while to connect, you can insert a pause so you don't have to wait to hear the dialling tone.

To insert a dialling pause, simply enter the number you usually dial for an outside line and then press .

### Using additional services

Your phone should be able to support services such as call waiting and conference calls. You'll need to check with your telephone network provider for further information on these services.



# Appendix

**Helpline UK 0844 800 6503**

(See page 43 for costs and hours of operation)

# Appendix

## Safety notes

Please make sure you read this user guide carefully and keep it for further use.

## Intended use

The telephone is suitable for telephoning within a analogue public telephone network system. Any other use is considered unintended use. Unauthorised modification or reconstruction is not permitted. Under no circumstances open the device or attempt any repair work yourself.

## Installation location

Make sure your phone:

- is on a dry, flat and stable surface or mounted to a wall.
- isn't a trip hazard with its cables.
- isn't exposed to smoke, dust, vibration, chemicals, moisture, heat and direct sunlight.
- is at least one metre from other electrical appliances to avoid mutual interference.

Make sure that the access to the power adapter plug is not obstructed by furniture or such.

## Power supply

**Caution: Only use the power adapter plug supplied because other power supplies could damage the telephone. Ensure access to the power adapter plug is not obstructed by furniture or such.**

The included mains adapter meets the eco-design requirements of the European Union (Directive 2005/32/EG). Thus, its power consumption is considerably lower, both in operated as well as in non-operated mode, compared with the mains adapter of previous design.



- Energiesparend
- Economisant l'énergie
- A risparmio di energia
- Energy efficient

## Hearing aid compatibility

Your phone works with most popular hearing aids. However, given the wide range of hearing aids available, we can't guarantee that your phone will function fully with every hearing aid.

**Important: Your phone can produce very high sound when Boost is switched on. Please take care if the handset is used by others.**

## Disposal

You are obliged to dispose of consumable goods properly in accordance with the applicable legal regulations.

The symbol on this product indicates that electrical and electronic apparatus and batteries must be disposed of **separately** from domestic waste at suitable collection points provided by the public waste authorities. Batteries can also often be disposed of at the point of sale.



Packaging materials must be disposed of according to local regulations.



## Help and support / Troubleshooting guide

### Helpline

If you need some help and you're in the UK, please first check and see if your problem can be solved using the troubleshooting guide below. If it can't , please call us on 0844 800 6503 (using a UK landline, at the time of going to print: calls cost 6p for connection charge and then 5p a minute. Mobile costs may vary). Lines are open Monday to Friday, 9am to 5pm, excluding public holidays. If you've a claim on your 2-year guarantee, please contact your supplier.

### I can't make phone calls

- Make sure the phone cable is connected properly. If it is, there may be a fault. Please make sure you're using the phone cable that came with your phone.

### Some features e. g. the boost function and handsfree are not working

- Check the power supply.
- Make sure the batteries are inserted correctly, they are of the correct type and they are not exhausted.

### The display of incoming call numbers is not working

- Check you have this service on your phone line. Please call your network provider.
- The caller may have withheld their phone number.

**Helpline UK 0844 800 6503**

(See on this page for costs and hours of operation)

## Maintenance

- Please clean your equipment's surfaces with a soft, fluff-free cloth.
- Never use cleaning agents or solvents.

## Guarantee

AMPLICOMMS equipment is produced and tested according to the latest production methods. The implementation of carefully chosen materials and highly developed technologies ensure trouble free functioning and a long service life. The terms of the guarantee do not apply where the cause of the equipment malfunction is the fault of the telephone network operator or any interposed private branch extension system. The terms of the guarantee do not apply to the rechargeable batteries or power packs used in the products. The period of guarantee is 24 months from the date of purchase.

All deficiencies resulting from material of production faults which occur during the period of guarantee will be eliminated free of charge. Rights to claims under the terms of guarantee are annulled following intervention by the purchaser or third parties. Damage caused as a result of improper handling or operation, incorrect positioning or storing, improper connection or installation, Acts of God or other external influence are not covered by the terms of guarantee.



In the case of complaints, we reserve the right to repair or replace defect parts or provide a replacement device. Replacement parts or devices become our property.

Rights to compensation in the case of damage are excluded where there is no evidence or intent or gross negligence by the manufacturer.

If your equipment shows signs of defect during the period of guarantee, please return to the sales outlet in which you purchased the AMPLICOMMS equipment together with the purchase receipt. All rights to claims under the terms of guarantee in accordance with this agreement must be asserted exclusively with regard to your sales outlet.

Two years after the purchase of our products, claims under the terms of guarantee can no longer be asserted.

## Declaration of conformity

This device fulfils the requirements stipulated in the EU directive:



1999/5 EU directive on radio equipment and telecommunications terminal equipment and the mutual recognition of their conformity.

Conformity with the above mentioned directive is confirmed by the CE symbol on the device.

To view the complete Declaration of Conformity, please refer to the free download available on our website [www.amplicomms.com](http://www.amplicomms.com)



# Index

**Helpline UK 0844 800 6503**  
(See page 43 for costs and hours of operation)

# Index

## A

Automatic emergency call . . . . . 31

## B

Batteries . . . . . 7

Box contents. . . . . 6

## C

Calls list . . . . . 17, 26

Chain dialling . . . . . 20

Connecting the telephone . . . . . 7

Creating phone book entries . . . . 23

## D

Declaration of conformity . . . . . 45

Dialling . . . . . 14

Display icons . . . . . 10

Disposal . . . . . 42

## E

Editing entries in the phone book 23

Emergency call . . . . . 19

Emergency calls via the emergency  
call unit . . . . . 32

Emergency calls via the  
telephone . . . . . 32

Ending a call . . . . . 14

Entering a name . . . . . 22

## G

Guarantee . . . . . 44

## H

Handset receiver tone . . . . . 16

Handset receiver volume . . . . . 16

Handsfree mode . . . . . 15

Handsfree volume . . . . . 17

Hearing aid . . . . . 41

## I

Installation location . . . . . 40

Intended use . . . . . 40

## M

Maintenance . . . . . 44

Missed calls . . . . . 17

Muting the microphone . . . . . 17

**O**

One-touch dialling . . . . . 19

**P**

Phone book . . . . . 22

Power supply . . . . . 41

**R**

Record names to phonebook  
entries . . . . . 24

Recording an outgoing alert  
message . . . . . 30

Redial . . . . . 17

Ringer volume . . . . . 16

**S**

Safety notes . . . . . 40

Starting/Ending the automatic  
emergency call . . . . . 33

**T**

Taking a call . . . . . 15

**W**

Wall mounting . . . . . 9

# Notes











Distributed by: Audioline GmbH, D-41460 Neuss

08/2013 – Issue 1.0

