

Aprilaire®

Premium Programmable Thermostat



Safety & Installation Instructions

Model 8570

READ AND SAVE THESE INSTRUCTIONS

TABLE OF CONTENTS

	<u>PAGE</u>		<u>PAGE</u>
SPECIFICATIONS	1	5. WIRE THE THERMOSTAT TO THE HVAC EQUIPMENT	8
WIRE REQUIREMENTS	2	Diagram 1 – Single-Stage Furnace and AC	9
1. SELECT A MOUNTING LOCATION	3	Diagram 2 – Two-Stage Furnace and AC	10
2. OPEN THE THERMOSTAT	4	Diagram 3 – Two-Stage Roof Top Unit	11
3. MOUNT THE THERMOSTAT BASE TO THE WALL	5	Diagram 4 – Boiler with AC	12
4. SET THE CONFIGURATION DIP SWITCHES ON THE THERMOSTAT CIRCUIT BOARD	6	Diagram 5 – Radiant Floor 1st Stage Heat with Furnace 2nd Stage Heat and AC	13
		Diagram 6 – Single-Stage Heat Pump	14
		Diagram 7 – Two-Stage Heat Pump	15
		6. OPTIONAL – INSTALL AN OUTDOOR TEMPERATURE SENSOR	16

	<u>PAGE</u>
7. OPTIONAL – INSTALL AN AUTOMATIC HUMIDIFIER CONTROL (AHC)	19
8. OPTIONAL – INSTALL AN INDOOR TEMPERATURE SENSOR	21
9. THERMOSTAT STARTUP	23
Verify Outdoor Temperature Sensor	24
Check Fan Operation	24
Verify AHC Connection	24
Check Heating Operation	26
Check Cooling Operation	28
Check Emergency Heat Operation (Heat Pumps Only)	29

	<u>PAGE</u>
10. CUSTOMIZE THE APPLICATION SETTINGS	30
Differential	30
Offset	31
Progressive Recovery	31
Balance Points (Heat Pumps Only)	32
Input Dealer Contact Information	33
Blower Extension for Humidity Control	34
Monitors – Air Filter, Service Humidifier, UV Lamp, Service HVAC	35

SAFETY INSTRUCTIONS

Read this Installation Manual before beginning installation of the Aprilaire® 8570 Thermostat. For questions call Research Products Corporation at (800) 334-6011.

WARNING

1. 120 Volts may cause serious injury from electrical shock. Disconnect electrical power to the HVAC equipment before starting installation. This thermostat is not a 120-volt (line voltage) device.
2. Improper installation may cause serious injury from electrical shock. This product must be installed by a qualified heating and air conditioning contractor in accordance with NEC Standards and applicable local and state codes.
3. Mercury is toxic and may be hazardous to health. Any replaced thermostats containing mercury must be disposed of properly. Contact local authorities for disposal information.

MODEL 8570 SPECIFICATIONS

Electrical

Thermostat Voltage:	24-volts \pm 20% AC or DC
Total Load Current:	2A
Single Output Load Current:	1A
Solid State Output Residual Current:	Less than 5 mA
Voltage Drop at Solid State Outputs:	Less than 1-volt

Thermal

Operating Range:	32°F – 99°F (0 C – 37 C)
Display Accuracy:	\pm 1°F between 60°F and 80°F, \pm 2°F outside this range
Control Accuracy:	\pm 1°F
Control Range Heat:	40°F – 88°F (4 C – 30 C)
Control Range Cool:	42°F – 90°F (6 C – 32 C)
Heat/Cool Deadband:	2°F or C
1st Stage Differential:	Adjustable 1°F – 3°F (1°F default)
2nd Stage Differential:	Adjustable 1°F – 3°F (1°F default)
Temperature Offset:	Adjustable 1°F – 4°F

WIRE REQUIREMENTS

Figure 1 and the table show the number of wires that must be available at the thermostat in stand-alone thermostat systems (i.e. not as part of an Aprilaire® Model 6504 Intelligent Zone System). **Figure 1** shows optional connections to both an outdoor temperature sensor and an Aprilaire® Automatic Humidifier Control (AHC), but only one or the other can be used. All wire is standard 18-24 gauge thermostat cable.

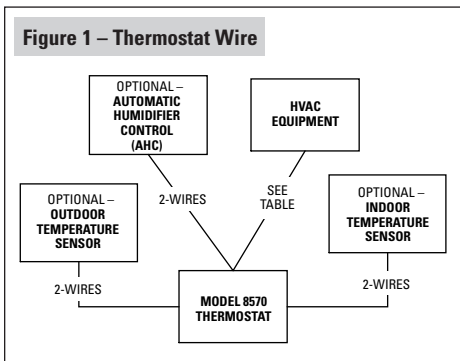

When this thermostat is connected to a Model 6504 as shown in **Figure 2**, only one four-wire cable need be run from the thermostat to the Model 6504. Use standard 18-24 gauge thermostat cable.

Application	# Wires	Diagram (Page)
Single-Stage Furnace/AC	5	1 (9)
Two-Stage Furnace/AC	7	2 (10)
Two-Stage Roof Top Unit	7	3 (11)
Boiler w/AC (2-transformer)	6	4 (12)
Radiant 1st Stage Heat, Furnace 2nd Stage and AC	6	5 (13)
Single-Stage Heat Pump	6	6 (14)
Two-Stage Heat Pump	8	7 (15)

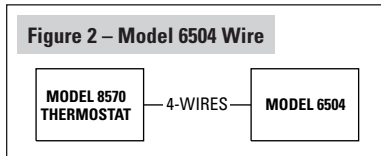

(1) SELECT A MOUNTING LOCATION

If installing the thermostat alone...

- Mount on an interior wall, in a frequently occupied space.
- Keep the thermostat 18" from an outside wall.
- Mount the thermostat approximately 5 feet above the floor. Height requirements are different for compliance with the Americans with Disabilities Act (ADA) – 48" maximum height for forward reach and 54" maximum height for side reach.
- Thermostat can be mounted to a vertical junction box (j-box).
- **DO NOT** mount the thermostat:
 - behind doors, in corners or other dead air spaces.
 - in direct sunlight or near lamps, appliances or other sources of heat.
 - on an outside wall or wall exposed to an unconditioned space (i.e. garage).
 - in the flow path of a supply register, in stairways or near outside doors.
 - on a wall where concealed pipes or ductwork could influence the sensor.
 - near sources of electrical interference such as arcing switch contacts.

If installing an indoor temperature sensor...

- Mount the thermostat where it can be readily accessed. Note that the backlighting illuminates whenever a button is pressed.
- Thermostat can be mounted on a vertical junction box (j-box).
- **DO NOT** mount the thermostat where the operating range temperatures will be exceeded (i.e. attic or unventilated equipment room).
- Mount the sensor in the same location as if installing a thermostat alone.

(2) OPEN THE THERMOSTAT

Use your hands to pull the thermostat face off of the base. Separate one side at a time. There are latches on either side of the thermostat.

If needed, the thermostat can be pried from the base by inserting a flat-head screwdriver (see **Figure 3**).

CAUTION

Loss of internal programs may result from static discharge to thermostat circuit board. Avoid touching the circuit board and touch a grounded metal object before handling the thermostat.

Figure 3

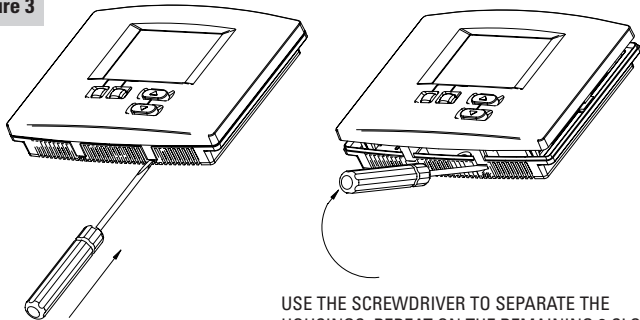

INSERT SCREWDRIVER INTO 1 OF 4 SLOTS (2 ARE ON THE TOPSIDE, 2 ARE ON THE BOTTOM SIDE)

USE THE SCREWDRIVER TO SEPARATE THE HOUSINGS. REPEAT ON THE REMAINING 3 SLOTS. **NOTE:** THE HOUSINGS WILL NOT COMPLETELY SEPARATE. PULL THE HOUSINGS APART WITH YOUR HANDS TO COMPLETELY SEPARATE.

(3) MOUNT THE THERMOSTAT BASE TO THE WALL

1. Place the wire opening in the base over the wire entry hole in the wall. Level the base (for appearance only) and mark the screw locations. See **Figure 4**.
2. Use the supplied screws and wall anchors to mount the thermostat to the wall. It is recommended that wall anchors be used for installation to drywall/sheet rock.
 - Drill a 3/16" hole for wall anchors.
 - Drill a 3/32" starter hole for screws only.
3. For junction box mounting, screws are field supplied. The thermostat can be installed on a vertical j-box.
4. Seal the wire entry hole(s) with caulk, drywall putty or insulation to prevent drafts from inside the wall cavity from affecting thermostat performance.

Figure 4

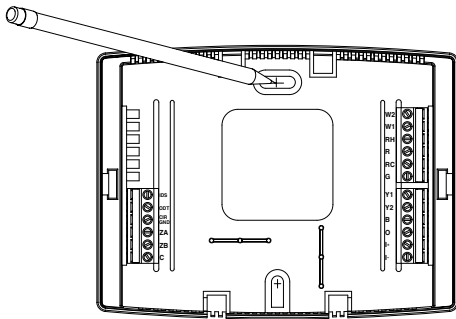

CAUTION

Minimize wire entry hole size and seal the hole – drafts from inside the wall could affect temperature readings.

(4) SET THE CONFIGURATION DIP SWITCHES ON THE THERMOSTAT CIRCUIT BOARD

There are four dip switches located on the back of the thermostat (on the circuit board) that must be set to properly configure the thermostat for operation with the equipment it is to control. **Figure 5** shows the default position for the four switches.

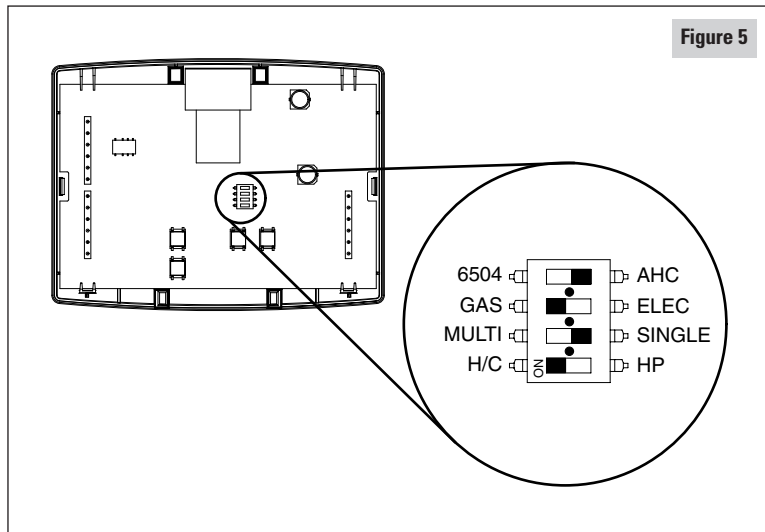

Figure 5

6504 or AHC – This switch is used to configure the thermostat installation as part of a Model 6504 Intelligent Zone System.

- Set to 6504 only if installing as part of a Model 6504 Intelligent Zone System.
- Set to AHC if the thermostat is to be wired to the HVAC equipment or standard zone system.

GAS or ELEC – When set to ELEC, the fan terminal (G) will be energized on a call for heat.

- Set to ELEC when the heat source is electric (such as strip heat).
- Set to GAS when the heat source is fossil fuel (oil, propane, natural gas). For heat pumps, when set to FOSSIL, the compressor terminal(s) will de-energize before the auxiliary heat terminal (W1) is energized, thus acting as a fossil fuel kit.

MULTI or SINGLE – When set to single, the second stage outputs (Y2 and W2) do not energize.

- Set to SINGLE for single-stage furnace/AC applications or single-stage compressor heat pump systems.
- Set to MULTI if the furnace or air conditioner is two-stage or if the heat pump has a two-stage compressor.

HEAT/COOL or HEAT PUMP – When set to HP the compressor terminal (Y1) is the first stage output for both heating and cooling.

- Set to HP when installed with heat pumps.
- Set to H/C when installed with furnace/AC systems, roof top units or boiler/AC combination systems.

STOP!

If installing this thermostat as part of a Model 6504 Intelligent Zone System, refer to the Model 6504 Installation Manual for wiring and checkout procedures. Continue Model 6504 installation with Step 10 (page 30). If wiring this thermostat directly to the HVAC equipment or standard zone control panel, continue with Step 5.

(5) WIRE THE THERMOSTAT TO THE HVAC EQUIPMENT

WARNING

120 volts may cause serious injury from electrical shock. Disconnect electrical power to the furnace and air conditioner before starting installation. This thermostat is not a 120 volt (line voltage) device.

1. Run a cable with the correct number of wires (see table) from the thermostat to the HVAC equipment.
2. Strip 1/4" of insulation from the end of the wires to be connected to the thermostat.
3. Strip no more insulation than is required to make a sound electrical connection at the HVAC equipment.
4. Wire the thermostat to the HVAC equipment according to the wiring schematic appropriate for your HVAC equipment.

Application	# Wires	Diagram (Page)
Single-Stage Furnace/AC	5	1 (9)
Two-Stage Furnace/AC	7	2 (10)
Two-Stage Roof Top Unit	7	3 (11)
Boiler w/AC (2-transformer)	6	4 (12)
Radiant 1st Stage Heat, Furnace 2nd Stage and AC	6	5 (13)
Single-Stage Heat Pump	6	6 (14)
Two-Stage Heat Pump	8	7 (15)

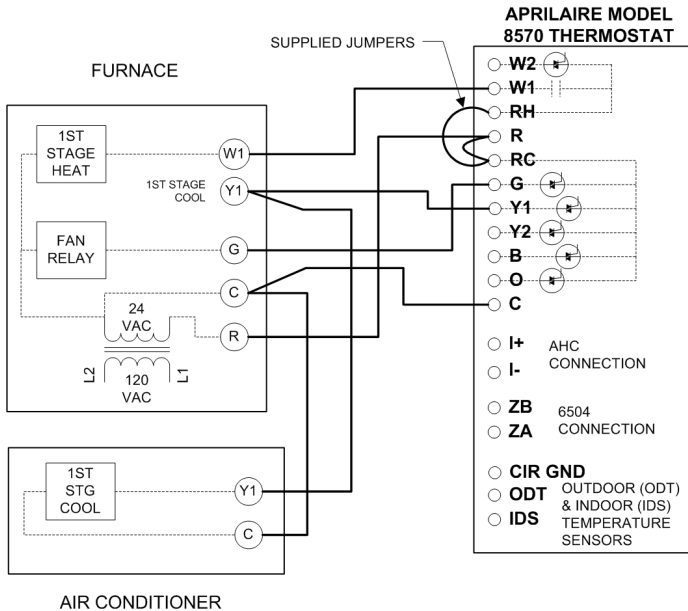
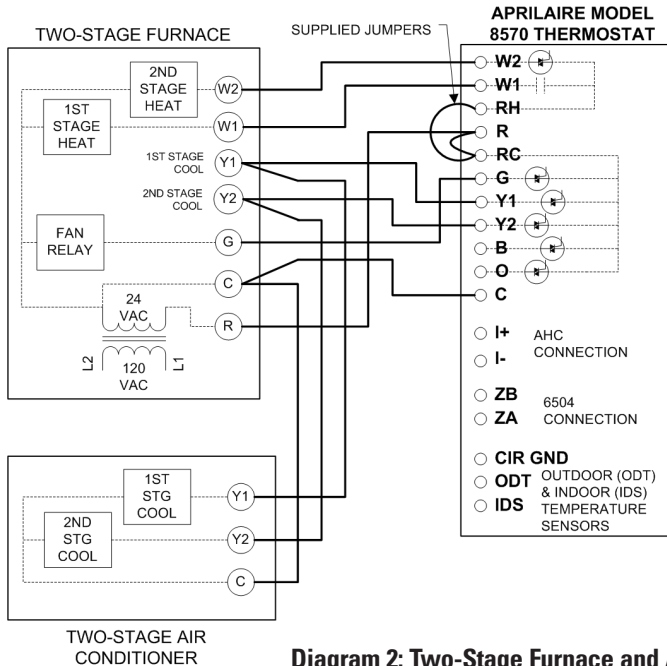

Diagram 1: Single-Stage Furnace and AC



THERMOSTAT CONFIGURATION SWITCH SETTINGS



ELEC/GAS - SET TO ELEC FOR ELECTRIC HEAT, SET GAS FOR FOSSIL FUEL HEAT

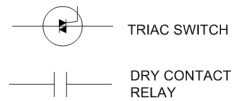

Diagram 2: Two-Stage Furnace and AC

**TWO-STAGE ROOF TOP UNIT
(RTU)**

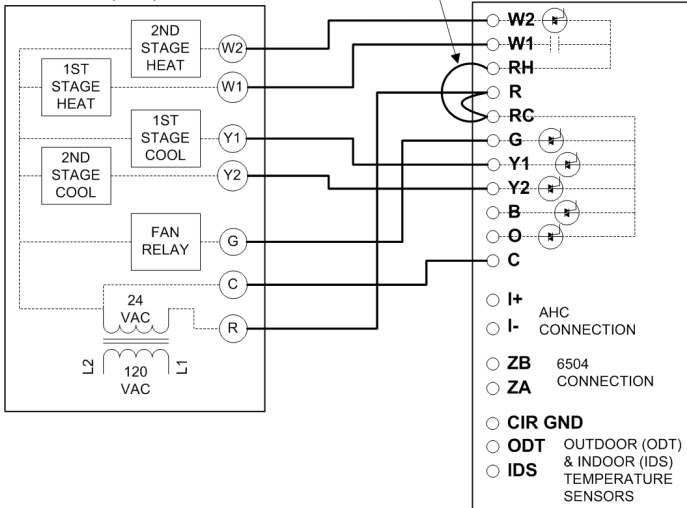

Diagram 3: Two-Stage Roof Top Unit

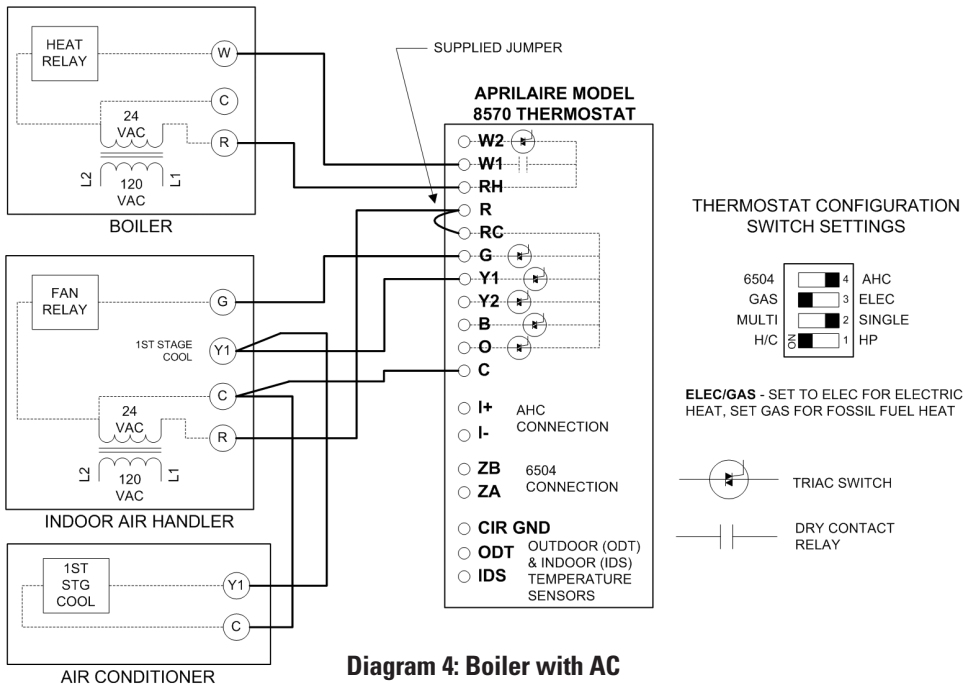

Diagram 4: Boiler with AC

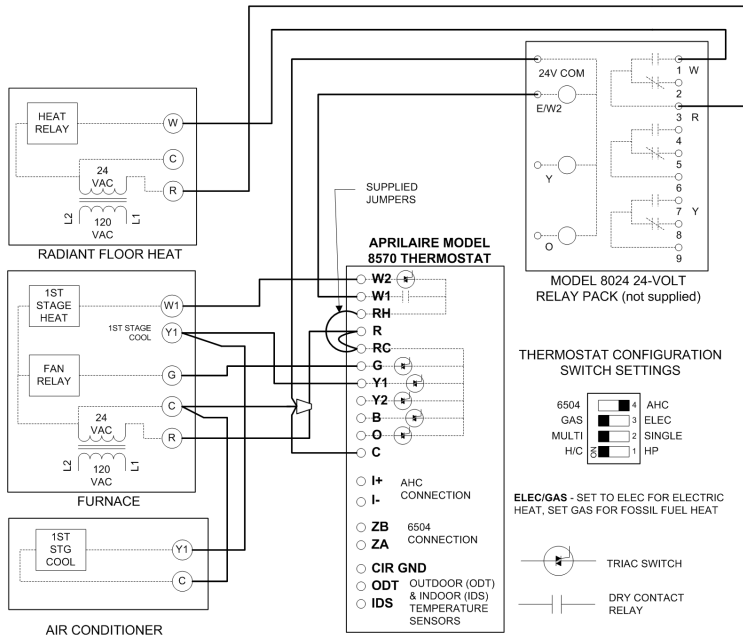
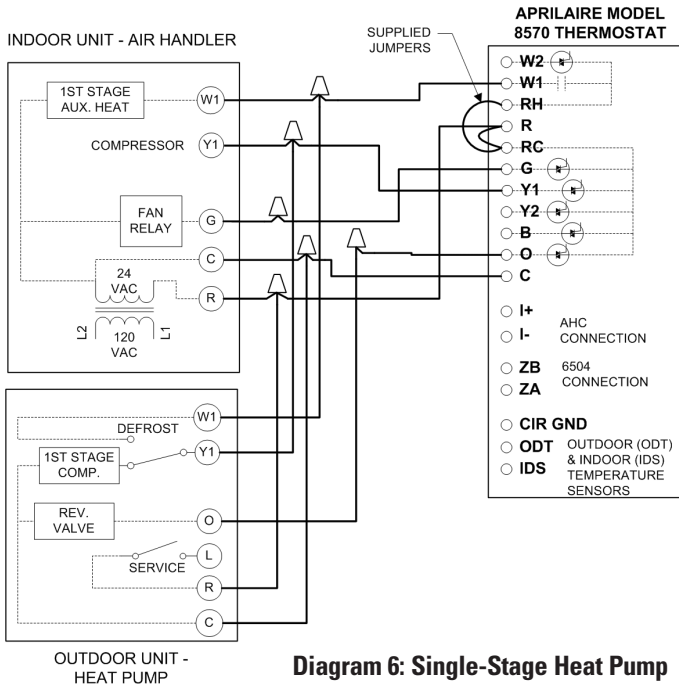
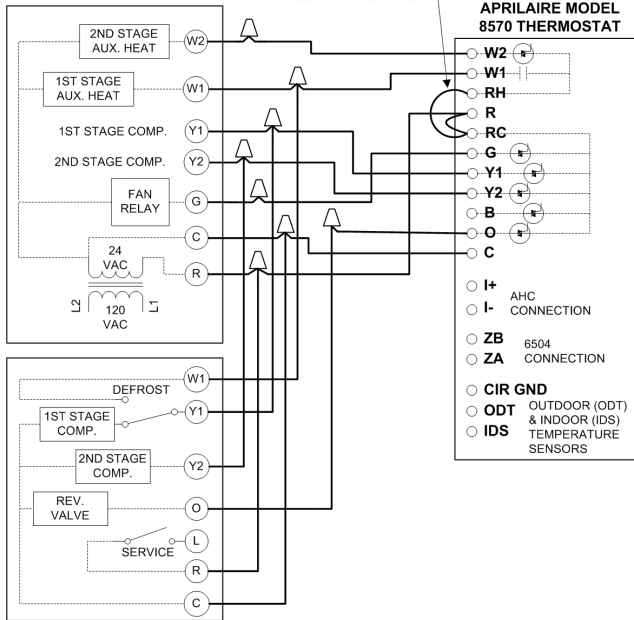

Diagram 5: Radiant Floor 1st Stage Heat with Furnace 2nd Stage Heat and AC



INDOOR UNIT - AIR HANDLER



APRILAIRE MODEL 8570 THERMOSTAT

THERMOSTAT CONFIGURATION SWITCH SETTINGS

6504	<input checked="" type="checkbox"/>	4	AHC
GAS	<input checked="" type="checkbox"/>	3	ELEC
MULTI	<input checked="" type="checkbox"/>	2	SINGLE
H/C	<input checked="" type="checkbox"/>	1	HP

ELEC/GAS - SET TO ELEC FOR ELECTRIC AUXILIARY HEAT, SET TO GAS FOR FOSSIL FUEL AUXILIARY HEAT (DUAL FUEL)



OUTDOOR UNIT - HEAT PUMP

Diagram 7: Two-Stage Heat Pump

(6) OPTIONAL – INSTALL AN APRILAIRE MODEL 8052 OUTDOOR TEMPERATURE SENSOR

Note: If an AHC is to be installed, do not wire an outdoor temperature sensor— see Step 7. The AHC uses its own outdoor temperature sensor, which can be read by the thermostat.

1. Mount the outdoor temperature sensor (see **Figure 6**).
- Locate on the North side of the building if possible. East and West are acceptable locations as long as the sensor will not be exposed to direct sunlight.
 - Mount above anticipated snow line.
 - Mount at least 3 feet away from exhaust vents and condensing units.
 - Maximum wire length from sensor to thermostat is 300 feet.
 - Under a soffit or under a wall overhang are recommended areas for mounting the sensor.
 - Follow any additional location requirements found on sensor installation instructions.

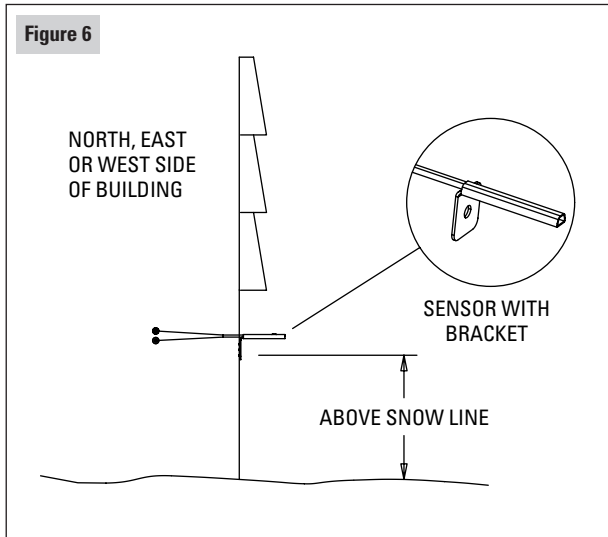

2. Run a 2-wire cable from the sensor to the thermostat.

CAUTION

Do not run the wire along side line voltage (120 VAC) or higher lines as this can cause erratic readings.

3. Take a resistance measurement before connecting to the ODT and CIR GND terminals to verify the sensor is properly installed. Measure the wires at the thermostat to account for wire splices.

- Use an ohmmeter to measure the resistance ($k\Omega$) of the sensor. The resistance reading will depend on the outdoor temperature (see table).

4. Wire the sensor to the thermostat (see **Figure 7**).

- Strip 1/4" of insulation from the two sensor wires.
- Connect the sensor wires to the ODT and CIR GND terminals of the thermostat. The wiring is not polarity sensitive, so either wire can be connected to either thermostat terminal.

OUTDOOR TEMPERATURE (°F)	RESISTANCE ($k\Omega$)
-30	230.6
-20	163.8
-10	117.6
0	85.4
10	62.6
20	46.3
30	34.6
40	26.1
50	19.9
60	15.3
70	11.9
80	9.4
90	7.4
100	5.9

Figure 7

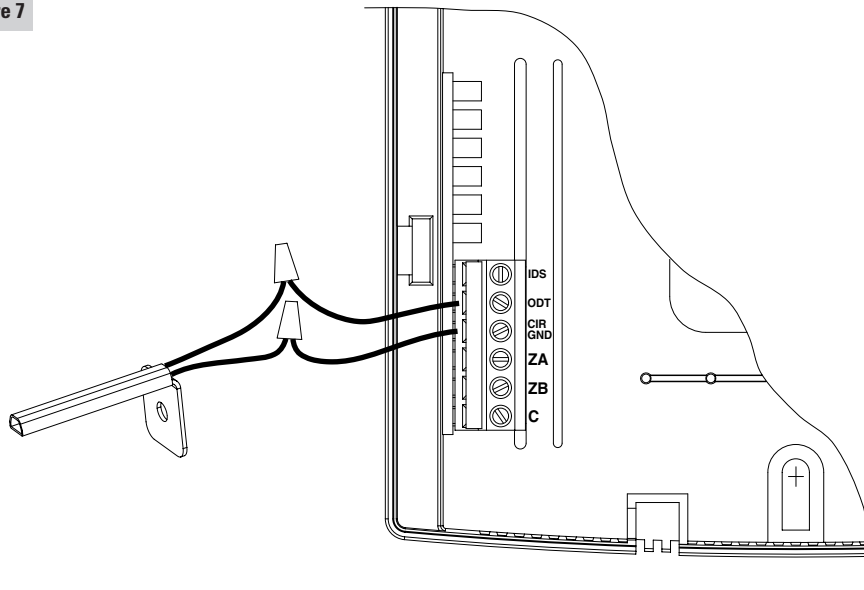

(7) OPTIONAL – INSTALL AN AUTOMATIC HUMIDIFIER CONTROL (AHC)

Note: The AHC uses its own outdoor temperature sensor, which is read by the thermostat. If an AHC is to be installed, do not wire an outdoor temperature sensor to the ODT terminal of the thermostat.

1. Mount the AHC and its outdoor temperature sensor.
 - Follow the directions provided with the AHC except **do not mount the AHC temperature sensor in a fresh air intake. The temperature sensor must be mounted outside.**
 - Maximum wire length from AHC to thermostat is 300 feet.
 - The AHC must have constant power. **DO NOT power the AHC through furnace accessory terminals.**
 - DO NOT operate the AHC in Manual Mode – this will result in the outdoor temperature shown on the thermostat to always be 20°F.
2. Run a 2-wire cable from the AHC to the thermostat.

CAUTION

Do not run the wire along side line voltage (120 VAC) or higher lines as this can cause erratic readings.

3. Wire the AHC to the thermostat (see **Figure 8**).
 - Strip 1/4" of insulation from the ends of the wires.
 - Connect the I- terminal of the AHC to the I- terminal of the thermostat.
 - Connect the I+ terminal of the AHC to the I+ terminal of the thermostat.
4. You will need to power up the thermostat to verify the connection. Refer to step 5 of THERMOSTAT START UP on page 24.
5. After completing the thermostat installation, you will also need to verify proper operation of the AHC – see AHC installation instructions for details on how this is done.

WARNING

Improper installation may cause serious injury from electrical shock. Do not power up humidifier before completing the thermostat installation.

Figure 8

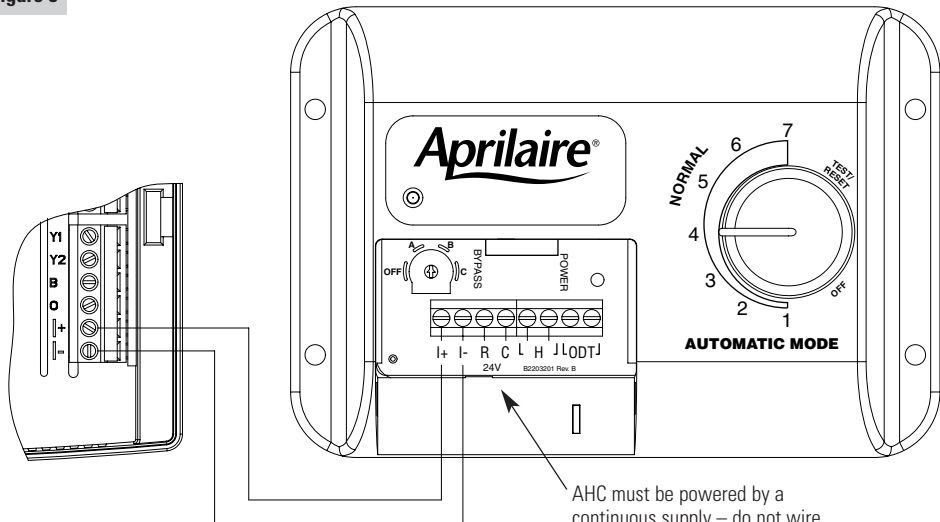

AHC must be powered by a continuous supply – do not wire to furnace accessory terminals.

(8) OPTIONAL – INSTALL AN APRILAIRE MODEL 8051 INDOOR FLUSH MOUNT TEMPERATURE SENSOR

1. Mount the indoor temperature sensor.
 - Locate the sensor as you would locate a thermostat.
 - Maximum wire length from sensor to thermostat is 300 feet.
 - Follow the installation instructions provided with the sensor.
2. Run a 2-wire cable from the sensor to the thermostat.

CAUTION

Do not run the wire along side line voltage (120 VAC) or higher lines as this can cause erratic readings.

3. Take a resistance measurement before connecting to the IDS and CIR GND terminals to verify the sensor is properly installed.
 - Use an ohmmeter to measure the resistance ($k\Omega$) of the sensor. The resistance reading will depend on the indoor temperature (see table from OUTDOOR SENSOR installation section on page 17).
4. Wire the sensor to the thermostat (see **Figure 9**).
 - Strip 1/4" of insulation from the two sensor wires.
 - Connect the sensor wires to the IDS and CIR GND terminals of the thermostat. The wiring is not polarity sensitive, so either wire can be connected to either thermostat terminal.

Figure 9

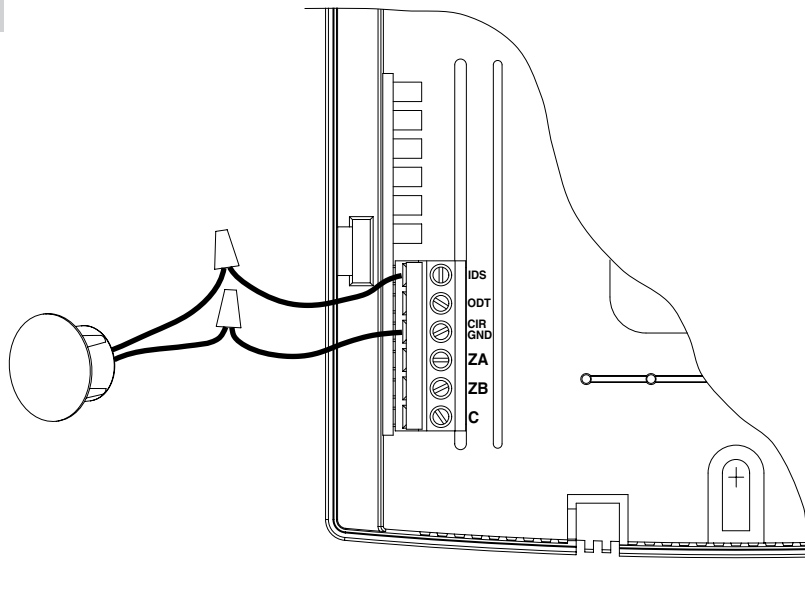

(9) THERMOSTAT STARTUP – STAND ALONE APPLICATIONS

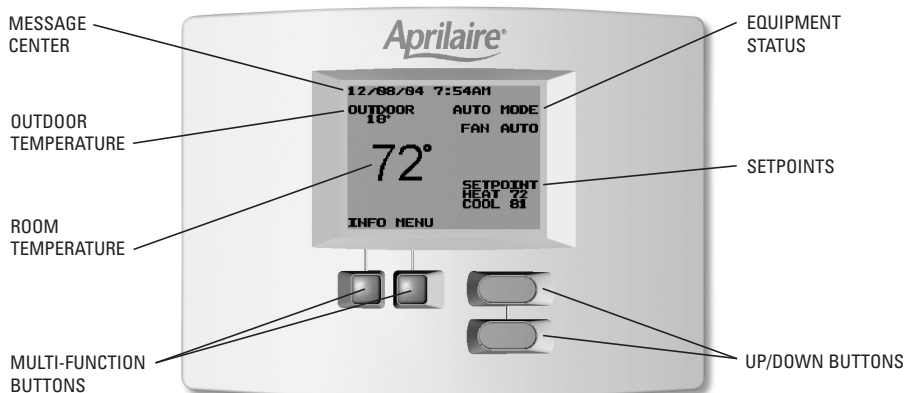

NOTE: Refer to the Owner's Manual for thermostat operating instructions.

1. PLACE THE THERMOSTAT ON THE BASE.
2. TURN ON POWER TO THE HVAC SYSTEM.
 - The display will show the Aprilaire screen for approximately 5 seconds (up to 10 seconds if installed as part of a Model 6504 Intelligent Zone System).
 - After this initial screen the thermostat will enter operational mode.
3. VERIFY OUTDOOR TEMPERATURE SENSOR CONNECTION (if optional outdoor temperature sensor installed).
 - If an outdoor temperature sensor has been installed and is operational, an outdoor temperature will appear on main display.
4. CHECK FAN OPERATION
 - Turn on the fan (set to ON).
 - The thermostat G terminal will energize and the system blower will start. The Fan Status on the display will show "FAN ON."

- **If an AHC has been installed, allow the fan to operate for no less than 40 seconds.** If an AHC is not part of this installation, you can turn the fan off at any time. A humidity value can be displayed only after at least 40 seconds of blower run-time to ensure the humidity reading is representative of the room air.
 - Turn the fan off (set to AUTO).
5. VERIFY AHC CONNECTION (if optional Automatic Humidifier Control installed).
 - Ensure that the AHC has power (the green status light on the AHC should be on) and make sure the AHC is functioning properly – see AHC installation procedure for start up and diagnostics.
 - From the Main Screen, press the "INFO" button.
 - The outdoor temperature and relative humidity will be displayed for five seconds after which the contact screen will be displayed (see page 33 for additional information on the contact screen).
 - When the humidifier is operating, the message "HUMIDIFIER ON" appears at the message center, alternating with the time and date and any other currently active messages.

TROUBLESHOOTING – AHC CONNECTION

Symptom	Cause
No RH display, no outdoor temperature display	Miswiring – Check wire colors to verify I- at AHC is connected to I- at thermostat and I+ is connected to I+.
	AHC power source – When wired to the Model 8570 thermostat, the AHC must be wired to a continuously ON power source. Use voltmeter to verify presence of 24VAC (nominal) at AHC.
	AHC not operating correctly – check red diagnostic light on AHC.
No RH display, outdoor temperature OK	No valid reading available – run fan for at least 40 seconds.
RH display, outdoor temperature @ 20°F	AHC set for manual mode of operation. Wire an outdoor sensor to the AHC or wire an outdoor sensor to the thermostat.

6. CHECK HEATING OPERATION

Notes:

1. To avoid the minimum off times during system checkout, always start and end the check out procedure in the OFF mode.

2. Do not operate heat pumps in the heating mode at high outdoor temperatures for extended periods of time.

- Set the thermostat to the OFF mode.
- Set the thermostat to the HEAT mode:
 - The B terminal will energize when in the Heat mode.
- Raise the heat setting to 5° higher than the room temperature to initiate a 1st stage heat call. The mode display will change from "HEAT MODE" to "HEATING", which will flash when the thermostat is calling for heat:
 - Furnace, Boiler: W1 (and G if GAS/ELEC dip switch is set in the ELEC position) terminals will energize.
 - Heat pumps: Y1 and G terminals will energize.
- Wait for 2nd Stage:
 - Furnace, Boiler: Minimum-on time for 1st stage is 2 minutes.
 - W1, W2 (and G if GAS/ELEC dip switch set to the ELEC position) will energize.
 - Heat pumps: Minimum-on time for 1st stage is 4 minutes.
 - Y1, W1 and G terminals will energize if SINGLE/MULTI dip switch set to SINGLE and ELEC/GAS dip switch set to ELEC.
 - Y1, Y2 and G terminals will energize if SINGLE/MULTI dip switch set to MULTI.
 - W1 will energize if SINGLE/MULTI set to SINGLE **and** ELEC/GAS set to GAS.
- Wait 4 minutes for 3rd Stage (multi-stage compressor heat pump systems only):
 - Y1, Y2, W1 and G terminals will energize if SINGLE/MULTI set to MULTI and ELEC/GAS set to ELEC.
 - W1 will energize if SINGLE/MULTI set to MULTI and ELEC/GAS set to GAS.
- Set the thermostat to the OFF mode.

TROUBLESHOOTING – HEATING OPERATION

Symptom	Cause
Thermostat does not call for heat	Minimum-off times. Change the mode to OFF first, then change the mode to HEAT and make a call for heat.
Heating does not come on at all	RH terminal not connected – see wiring diagrams.
	Heating equipment power not on.
Auxiliary Heat does not come on	High Balance point limit – set balance point higher than outdoor temperature or disconnect outdoor temperature sensor during system checkout.
Fan stays on after heat call	Furnace plenum sensor keeps fan on – normal.
	Blower Extension for humidifier operation. Verify that the message "HUMIDIFYING" appears at the message center, alternating with the time and date and any other currently active messages.
Fan comes on before heat starts, or Fan does not come on with heat	Change position of ELEC/GAS dip switch – ELEC for electric heat systems (fan on with heat call) or to GAS for fossil fuel systems where the fan is controlled internally by the heating equipment.
Cooling comes on instead of heat	Reversing valve wiring.
	Miswiring – check wire colors at thermostat and HVAC equipment.
Takes longer than 4 minutes for auxiliary heat to come on after compressor heat.	SINGLE/MULTI dip switch set incorrectly – set to SINGLE for single-stage compressor systems.

7. CHECK COOLING OPERATION

Notes:

- 1. To avoid the minimum off times during system checkout, always start the check out procedure in the OFF mode.**
 - 2. Do not operate air conditioning at low outdoor temperatures. Refer to equipment manufacturer's recommendations for safe operating temperatures.**
- Set the thermostat to the OFF mode.

- Set the thermostat to the COOL mode:
 - The O terminal will energize when in the Cool mode.
- Lower the cool setting to 5° below the room temperature to initiate a 1st stage cool call. The mode display will change from "COOL MODE" to "COOLING", which will flash when the thermostat is calling for cooling:
 - Y1 and G terminals will energize.
- Wait 4-minutes for 2nd Stage:
 - Y1, Y2 and G terminals will energize.
- Set the thermostat to the OFF mode.

TROUBLESHOOTING – COOLING OPERATION

Symptom	Cause
Thermostat does not call for cooling	Minimum-off times. Change the mode to OFF first, then change the mode to COOL and make a call for cooling.
Cooling does not come on at all	RC terminal not connected – see wiring diagrams.
	Cooling equipment power not on.
Heat comes on instead of cooling	Reversing valve wiring.
	Miswiring – check wire colors at thermostat and HVAC equipment.

8. CHECK EMERGENCY HEAT OPERATION (Heat Pumps Only)

Notes:

1. To avoid the minimum off times during system checkout, always start the check out procedure in the OFF mode.

- Set the thermostat to the OFF mode:
- Set the thermostat to the EMERGENCY HEAT (EMERG) mode:
 - The B terminal will energize when in the Emergency Heat mode.

- Raise the heat setting to 5° higher than the room temperature to initiate a 1st stage heat call. The mode display will change from “E-HEAT MODE” to “HEATING”, which will flash when the thermostat is calling for heat:
 - W1 (and G if GAS/ELEC dip switch is set in the ELEC position) terminals will energize.
- Wait for 2nd Stage:
 - Minimum-on time for 1st stage is 2 minutes.
 - W1, W2 (and G if GAS/ELEC dip switch set to the ELEC position) will energize.
- Set the thermostat to the OFF mode.

TROUBLESHOOTING – EMERGENCY HEAT OPERATION

Symptom	Cause
Thermostat does not call for heat	Minimum-off times. Change the mode to OFF first, then change the mode to EMERGENCY HEAT and make a call for heat.
Emergency Heat does not come on at all	RH terminal not connected – see wiring diagrams.
	Heating equipment power not on.
Fan comes on before heat starts, or Fan does not come on with heat	Change position of ELEC/GAS dip switch – ELEC for electric heat systems (fan on with heat call) or to GAS for fossil fuel systems where the fan is controlled internally by the heating equipment.

(10) CUSTOMIZE THE APPLICATION SETTINGS

1. DIFFERENTIAL

Determines the temperature above/below the temperature setting at which the heating or cooling equipment will turn on. For example, a heat temperature setting of 70°F with a differential of 2° will result in the equipment turning on and off to maintain the temperature between 68°F and 70°F. If the second stage differential is also 2°, the second stage would be used to ensure the temperature did not drop below 66°. However, once the second stage is turned on, it will stay on until the temperature again reaches the 70° setting. The default setting for the first stage and second stage differential is 1°.

To change the differential settings:

1. Make sure the thermostat is in the OFF mode.
2. Press and hold both the ▲ and ▼ buttons for 3 seconds.
 - The display will show the ADV. SETTINGS MENU.
3. Use the ▲ or ▼ button to highlight “SET DIFFERENTIAL” and press the SELECT button.
 - If the thermostat SINGLE/MULTI dip switch is set for MULTI, two differentials will appear, if set for SINGLE, only one will appear.
4. **To cancel**, press the BACK button. This will return you to the ADV. SETTINGS MENU.
5. **To change** the first stage differential, press the ▲ and ▼ button to raise or lower the setting. To change the second stage differential, press the SELECT button.
6. **To finish** and return to the ADV. SETTINGS MENU, press the SELECT button after the value(s) have been set.
 - **For heat pumps** – the auxiliary heat differential is the same as the first stage differential in single-stage heat pump applications and is the same as the second stage differential for two-stage heat pump applications.

2. OFFSET

All thermostats are factory calibrated to be accurate to within $\pm 1^\circ$ of true temperature. An offset is available to allow for agreement with field temperature measuring instruments. The value set will be added to the temperature sensed by the thermostat. The result will be displayed on the thermostat and will be used as the control value.

To change the offset:

1. Make sure the thermostat is in the OFF mode.
2. Press and hold both the ▲ and ▼ buttons for 3 seconds.
 - The display will show the ADV. SETTINGS MENU.
3. Use the ▲ or ▼ button to highlight “SET OFFSET” and press the SELECT button.
4. **To cancel**, press the BACK button.
5. **To change** the offset value, press the ▲ or ▼ button to raise or lower the setting between -4° and $+4^\circ$ ($^\circ\text{F}$ or $^\circ\text{C}$).
6. **To finish** and return to the ADV. SETTINGS MENU, press the SELECT button.

3. PROGRESSIVE RECOVERY

Progressive Recovery causes the thermostat to bring on the heating/cooling equipment before the programmed event start time, in order for the temperature to be at the programmed value by the programmed time. The feature can be turned on or off. When turned off, the heating/cooling equipment will not begin bringing the space temperature to the programmed value until the start of the event.

To turn Progressive Recovery on or off:

1. Make sure the thermostat is in the OFF mode.
2. Press and hold both the ▲ and ▼ buttons for 3 seconds.
 - The display will show the ADV. SETTINGS MENU.
3. Use the ▲ or ▼ button to highlight “PROGRESSIVE RECOVERY” and press the SELECT button.
 - **To cancel**, press the BACK button
 - **To change** whether Progressive Recovery is on or off, press the ▲ or ▼ button to highlight either ON or OFF.
 - **To finish** and return to the ADV. SETTINGS MENU, press the SELECT button.

4. BALANCE POINTS (HEAT PUMPS ONLY)

This feature is only available when the thermostat has been configured to operate heat pumps (see SET THE CONFIGURATION DIP SWITCHES on page 6) and only when an outdoor temperature is available to the thermostat. Outdoor temperature can come from an AHC or from an outdoor temperature sensor.

The low balance point is the outdoor temperature at or below which the thermostat will lockout the compressor(s) – only auxiliary heat will be used to satisfy heating demands. The high balance point is the outdoor temperature at or above which the thermostat will lockout the auxiliary heat – only compressor heat will be used to satisfy heating demands. Emergency heat operation is unaffected by the high balance point.

To change the balance points:

1. Make sure the thermostat is in the OFF mode.
2. Press and hold both the ▲ and ▼ buttons for 3 seconds.
 - The display will show the ADV. SETTINGS MENU.

3. Use the ▲ or ▼ button to highlight “SET BALANCE POINTS” and press the SELECT button.
4. **To cancel**, press the BACK button. This will return you to the ADV. SETTINGS MENU.
5. **To change the low balance point**, press the ▲ or ▼ button to raise or lower the temperature value (range is 0°F to 40°F).
6. **To change the high balance point**, press the SELECT button, then press the ▲ or ▼ button to raise or lower the temperature value (range is 40°F to 80°F).
7. **To finish** and return to the ADV. SETTINGS MENU, press the SELECT button after the value(s) have been set.

Important time saver: If the thermostat is installed as part of a Model 6504 Intelligent Zone System, the balance points only need to be changed at one thermostat. The Model 6504 will share the new settings with all connected thermostats.

5. INPUT DEALER CONTACT INFORMATION

During thermostat operation, the two multi-function buttons are labeled INFO and MENU. When the INFO button is pressed, the thermostat will display the humidity and temperature sensed by the AHC (if an AHC has not been installed the Aprilaire logo screen will appear), then the thermostat will display the thermostat model number and contact information. At installation, the contact information is blank and only the thermostat model number appears. You have the option of inputting this contact information with the name and number of your company. Twenty (20) characters are available for your company name. Space for a telephone number, including area code, is available.

To change the contact information:

1. Make sure the thermostat is in the OFF mode.
2. Press and hold both the ▲ and ▼ buttons for 3 seconds.
 - The display will show the ADV. SETTINGS MENU.
3. Use the ▲ or ▼ button to highlight “INPUT DEALER INFO” and press the SELECT button. This enters the company name screen.
4. **To cancel**, press the BACK button. This returns to the ADV. SETTINGS MENU. You must be at the first position when pressing the BACK button to return to the ADV. SETTINGS MENU.
5. **To delete a character**, press the BACK button.
6. **To enter a letter in the name of the company**, use the ▲ or ▼ buttons to scroll through the available characters. Press the SELECT button to enter the character. For spaces, press SELECT.
7. **To finish and go to the company number screen**, repeatedly press SELECT until all remaining characters have been filled with spaces, then press SELECT again.
8. **To delete a number**, press the BACK button.
9. **To enter a number**, use the ▲ or ▼ buttons to scroll between the available characters. Press the SELECT button to enter the character. The full 10-digit telephone number must be entered.
10. **To finish**, press the SELECT button after entering the 10th digit.

6. BLOWER EXTENSION FOR HUMIDITY CONTROL

If the heating equipment has not run long enough to allow the humidifier to meet the humidity demand, the thermostat will continue the blower after a heat call. One second before the thermostat turns off the heating terminal(s), the fan terminal will be energized thus extending blower operation. If the fan terminal was on as part of the heat call it will remain on, if it was not on it will be turned on. The thermostat will operate the blower for no less than 5 minutes after the heat call and not more than 15 minutes. This will allow the humidifier to continue to put moisture in the air to satisfy the humidity demand. This feature can be enabled or disabled and can only be used when an AHC is part of the installation.

Note: To take full advantage of this feature, the humidifier should be plumbed to hot water.

To enable blower extension:

1. Make sure the thermostat is in the OFF mode.
2. Press and hold both the ▲ and ▼ buttons for 3 seconds.
 - The display will show the ADV. SETTINGS MENU.

3. Use the ▲ or ▼ button to highlight “BLOWER EXTENSION” and press the SELECT button.
4. **To cancel**, press the BACK button
5. **To change** whether Blower Extension is enabled (on) or disabled (off), press the ▲ or ▼ button to highlight either ON or OFF.
6. **To finish** and return to the ADV. SETTINGS MENU, press the SELECT button.

Important: When the thermostat is installed as part of a Model 6504 Intelligent Zone System, leave this feature disabled. The Model 6504 performs this function.

7. MONITORS – AIR FILTER, SERVICE HUMIDIFIER, UV LAMP, SERVICE HVAC

The thermostat monitors time and can display scheduled reminders for the user to service their humidifier, change their filter and UV lamps, and to remind the user to schedule an HVAC system maintenance check. All monitors are strictly time based, so setting a filter monitor to three months will result in the change reminder being displayed in three months, regardless of how much the HVAC system has run in that period. All monitors can also be turned off for installations where one or more of the components may not be installed. When the thermostat has verified that a monitor setting has been reached, a message is displayed on the thermostat (at the message center location where date and time are normally displayed) and the label for the multi-function button normally labeled INFO changes to CALL DEALER.

To set humidifier, filter, UV and HVAC service reminder schedules:

1. Press the MENU button.
2. Use ▲ or ▼ button to highlight SETTINGS, then press the SELECT button. Press the BACK button to cancel.

3. Use ▲ or ▼ button to highlight MONITORS, then press SELECT. Press BACK to cancel.
4. Use ▲ or ▼ button to highlight the monitor you wish to set (AIR FILTER, SERVICE HUMIDIFIER, UV LAMP or SERVICE HVAC) then press the SELECT button. Press the BACK button to cancel.
5. Use ▲ or ▼ button to highlight the amount of time you wish to set then press the SELECT button. Press the BACK button to cancel.
6. Pressing the SELECT button, after setting the schedule, takes you back to the MONITORS screen.
 - To set additional reminder schedules return to step 3.
 - To finish, press the BACK button three times to return to normal operation.

Important: When an AHC is installed with the thermostat, either directly or as part of a Model 6504 Intelligent Zone System, the service humidifier monitor will automatically be set to AUTO. AUTO is not a choice unless an AHC is present. Set to AUTO, the AHC will initiate “service humidifier” based on humidifier type and run time.

DP #10006198
B2203358A



RESEARCH PRODUCTS CORPORATION P.O. BOX 1467 • MADISON, WI 53701-1467

Printed in U.S.A.