Operating instructions and spare parts list

Powder coating booth MagicCylinder



Translation of the original operating instructions

Documentation MagicCylinder powder coating booth

© Copyright 2007 Gema Switzerland GmbH

All rights reserved.

This publication is protected by copyright. Unauthorized copying is prohibited by law. No part of this publication may be reproduced, photocopied, translated, stored on a retrieval system or transmitted in any form or by any means for any purpose, neither as a whole nor partially, without the express written consent of Gema Switzerland GmbH.

MagicCompact, MagicCylinder, MagicPlus, MagicControl, OptiFlex, OptiControl, OptiGun, OptiSelect, OptiStar and SuperCorona are registered trademarks of Gema Switzerland GmbH.

OptiFlow, OptiCenter, OptiMove, OptiSpeeder, OptiFeed, OptiSpray, OptiSieve, OptiAir, OptiPlus, OptiMaster, MultiTronic, EquiFlow, Precise Charge Control (PCC), Smart Inline Technology (SIT) and Digital Valve Control (DVC) are trademarks of Gema Switzerland GmbH.

All other product names are trademarks or registered trademarks of their respective holders.

Reference is made in this manual to different trademarks or registered trademarks. Such references do not mean that the manufacturers concerned approve of or are bound in any form by this manual. We have endeavored to retain the preferred spelling of the trademarks, and registered trademarks of the copyright holders.

To the best of our knowledge and belief, the information contained in this publication was correct and valid on the date of publication. Gema Switzerland GmbH makes no representations or warranties with respect to the contents or use of this publication, and reserves the right to revise this publication and make changes to its content without prior notice.

For the latest information about Gema products, visit www.gemapowdercoating.com.

For patent information, see www.gemapowdercoating.com/patents or www.gemapowdercoating.us/patents.

Printed in Switzerland

Gema Switzerland GmbH
Mövenstrasse 17
9015 St.Gallen
Switzerland

Phone: +41-71-313 83 00

Fax.: +41-71-313 83 83

E-Mail: info@gema.eu.com

Table of contents

General safety regulations	5
Safety symbols (pictograms).....	5
Proper use.....	5
Product-specific safety measures	6
General information	6
Installation.....	6
Operating the equipment	7
Inspection check.....	7
Entering the booth.....	7
Repairs.....	7
About this manual	9
General information	9
Design and function	11
Field of application	11
Function description.....	11
Operational procedure	12
Powder flow.....	13
Booth – superstructure.....	14
Booth – basement.....	14
Exhaust air system with After Filter.....	15
Fire protection	15
Cleaning operation mode.....	15
Powder recovery	15
Automatic guns	16
Cleaning the guns	17
Technical data	19
MagicCylinder powder coating booth.....	19
Electrical data	19
Pneumatic data	19
Dimensions	19
Sound pressure level	19
Commissioning	21
Set-up and assembly	21
Installation.....	21
Cable connections / junctions	21
Grounding	21
Operation	23
Before switching on the booth.....	23
Switch on the booth	23
Switching off the booth.....	23

Alarm messages	24
Filter cleaning	24
Color change and cleaning	24
Maintenance	27
Maintenance and repair	27
Daily or after each shift	27
Weekly	27
Biannually	27
Maintenance and repair of the cyclone separator	28
Maintenance and repair of the sieve machine	28
Maintenance of the After Filter pressure gauges (filter and fan)	28
Replacing spare parts	28
Functional check	29
General information	29
Procedure of the function check	29
Decommissioning, storage	31
Introduction	31
Safety rules	31
Requirements on personnel carrying out the work	31
Storage conditions	31
Storage duration	31
Space requirements	31
Physical requirements	31
Hazard notes	31
Shut-down	32
Decommissioning	32
Cleaning	32
Disassembly/attachment of transport safety devices	32
Packing	32
Identification	32
Maintenance during storage	32
Maintenance schedule	32
Maintenance works	32
Return to service	32
Commissioning following storage	32
Packing, transport	33
Introduction	33
Safety rules	33
Requirements on personnel carrying out the work	33
Packing material	33
Transport	33
Data concerning goods to be transported	33
Mode of transportation	34
Loading, transferring the load, unloading	34
Troubleshooting	35
General information	35
Problem fixing	35
Setting values	37
Spare parts list	39
Ordering spare parts	39
MagicCylinder – Spare parts list	40

MagicCylinder – gun blow off equipment.....	42
MagicCylinder – door drive unit	44
MagicCylinder – Fan control unit	46

General safety regulations

This chapter sets out the fundamental safety regulations that must be followed by the user and third parties using the MagicCylinder powder coating booth.

These safety regulations must be read and understood before the MagicCylinder powder coating booth is put into operation.

Safety symbols (pictograms)

The following warnings with their meanings can be found in the Gema Switzerland operating instructions. The general safety precautions must also be followed as well as the regulations in the operating instructions.

**DANGER!**

Danger due to electrically live or moving parts. Possible consequences: death or serious injury

**WARNING!**

Improper use of the equipment could damage the machine or cause it to malfunction. Possible consequences: minor injuries or damage to equipment



**INFORMATION!**

Useful tips and other information

Proper use

1. The MagicCylinder powder coating booth is built to the latest specification and conforms to the recognized technical safety regulations and is designed for the normal application of powder coating.
2. Any other use is considered non-compliant. The manufacturer shall not be liable for damage resulting from such use; the user bears sole responsibility for such actions. If the MagicCylinder powder coating booth is to be used for other purposes or other substances outside of our guidelines then Gema Switzerland GmbH should be consulted.

3. Observance of the operating, service and maintenance instructions specified by the manufacturer is also part of conformity of use. The MagicCylinder powder coating booth should only be used, maintained and started up by trained personnel, who are informed about and are familiar with the possible hazards involved.
4. Start-up (i.e. the execution of a particular operation) is forbidden until it has been established that the MagicCylinder powder coating booth has been set up and wired according to the guidelines for machinery (2006/42 EG). EN 60204-1 (machine safety) must also be observed.
5. Unauthorized modifications to the MagicCylinder powder coating booth exempts the manufacturer from any liability from resulting damage.
6. The relevant accident prevention regulations, as well as other generally recognized safety regulations, occupational health and structural regulations are to be observed.
7. Furthermore, the country-specific safety regulations also must be observed.

Explosion protection	Protection type
 	IP54

Product-specific safety measures

General information

The MagicCylinder powder coating booth is a constituent part of the equipment and is therefore integrated in the system's safety concept.

If it is to be used in a manner outside the scope of the safety concept, then corresponding measures must be taken.



NOTE:

For further information, see the more detailed Gema safety regulations!

Installation

- Installation work performed by the customer must be carried out according to local regulations.
- Before starting up the plant a check must be made that no foreign objects are in the booth or in the ducting (input and exhaust air)
- All components must be grounded according to the local regulations before start-up.
- The booth grounding is to be checked at every start-up. The grounding connections are customer specific, and are made

on the base of the booth. The grounding of the workpieces and other plant units must also be checked.

Operating the equipment

In order to be able to operate the equipment safely, it is necessary to be familiar with the safety regulations, the operational characteristics and functioning of the various plant units.

For this purpose, read the safety notes, this operating manual and the operating instructions of the control unit with touch panel, before starting up the plant.

In addition, all further equipment-specific operating instructions, e.g. the OptiFlex and all additional components should also be read.

To obtain practice in operating the plant, it is absolutely essential to start the operation according to the operating instructions. Also, later on, they serve as a useful aid on possible malfunctions or uncertainty and will make many enquiries unnecessary. For this reason, the operating manual must always be available at the equipment.

Should difficulties arise, however, your Gema service center is always ready to assist.

Inspection check

The following points are to be checked at every booth start-up:

- No foreign material in the central suction unit in the booth and in the powder suction
- Pneumatic conduction and powder hose are connected to the dense phase conveyor
- Pneumatic conduction to the After Filter is connected, the filter element door is closed, the waste container is placed and fitted

Entering the booth



WARNING:

Danger of slipping and/or injury!

Repairs



WARNING:

Carrying out of repairs is only permitted when the booth is switched off, and must be done only by trained personnel!

About this manual

General information

This operating manual contains all the important information which you require for the working with the MagicCylinder powder coating booth. It will safely guide you through the start-up process and give you references and tips for the optimal use of your new powder coating system.

Information about the function mode of the individual system components – booth, gun control unit, and gun or powder injector – should be referenced to their corresponding documents.



DANGER:

Working without operating instructions

Working without operating instructions or with individual pages from the operating instructions may result in damage to property and personal injury if relevant safety information is not observed.

- ▶ Before working with the device, organize the required documents and read the section "Safety regulations".
 - ▶ Work should only be carried out in accordance with the instructions of the relevant documents.
 - ▶ Always work with the complete original document.
-

Design and function

Field of application

MagicCylinder coating booths are used for the electrostatic powder coating of all types of workpieces in large batches with frequent color changes. As part of the process controlled coating plant, they are laid out for fully automatic operation.

The most important characteristics of the MagicCylinder coating booths are:

- Superstructure and booth basement in plastic material
- Automatic floor cleaning (no powder accumulation)
- Central suction unit under the center of the booth
- Fast color change by one person
- The guns are arranged vertically

Function description

The principle of function is determined by the requirements placed on the booth, which are:

- The protection of the coating process from external influences, combined with keeping the area around the booth clean
- The powder recovery
- The avoidance of an explosive powder/air mixture inside the booth

An efficient exhaust air system is used to keep the area around the booth clean and to prevent explosive powder/air mixtures.

The fan in the After Filter extracts the air from the inside of the booth through the cyclone and afterwards through the filter elements. The air stream created thereby, flowing from the outside to the inside of the booth, prevents powder escaping to the environment of the booth, so that keeping the area around the booth clean is guaranteed. The maintenance of the air flow prevents as well the creation of dangerous powder/air mixtures.

The powder recovery takes place by the powder separation in the cyclone separator during operation.

The booth control takes place by the corresponding control unit with operating interface.

The gun control units are fitted into one or two control cabinets. The switching on and off of the guns takes place by the gap detection unit in the automatic mode.



NOTE:

More detailed information about the control units/components and the operating interfaces are found in the corresponding user manuals!

Operational procedure



NOTE:

Only the multiple color version is described in this user manual!

By switching on the booth, the fan in the After Filter starts up and after the start-up phase, the plant units which are interlocked with the booth are released.

The operational condition is reached, as soon as all external plant units such as chain conveyor, OptiCenter, reciprocators (optionally), fire protection (optionally) etc. are switched on.

The operating functions in the OptiCenter can be released now and the coating process can begin. This process is interrupted only if a ventilator motor malfunction is present. Other malfunctions are indicated by an alarm or a message, displayed on the control cabinet.

The suction effect of the filters is monitored during operation. Therefore, the differential pressure and thus the suction performance of the exhaust air system is measured. A blockage of the filter elements is indicated by a decrease of the suction performance (the differential pressure arises). By reaching a fixed preset value, a signal lamp on the control cabinet illuminates and at the same time an alarm sounds.

(Detailed information about the After Filter is found in the corresponding operating manual).

Powder flow

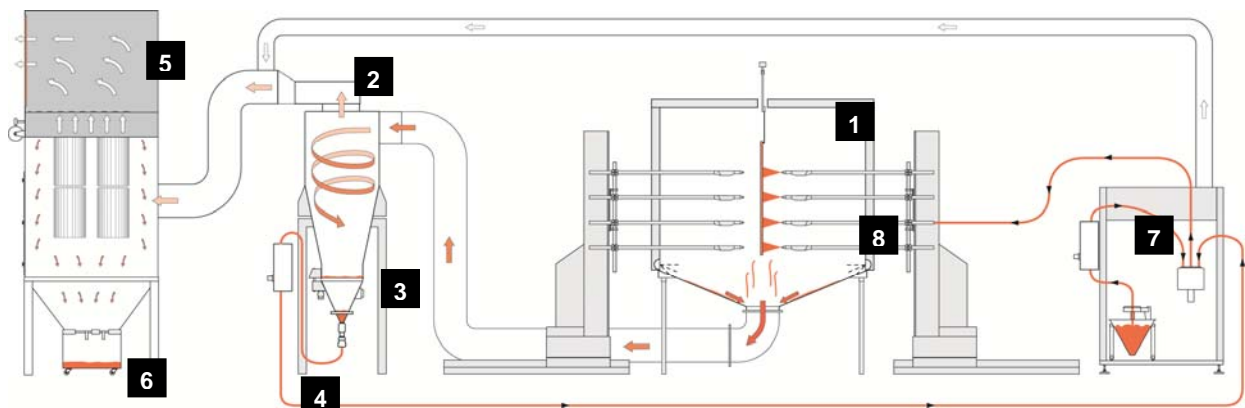

MagicCylinder – Powder flow in the plant

- | | |
|------------------------|--------------------|
| 1 Booth | 5 After Filter |
| 2 Cyclone separator | 6 Refuse container |
| 3 Sieve | 7 OptiCenter |
| 4 Dense phase conveyor | 8 Automatic guns |

The powder container is located in the OptiCenter (7). Here, the powder is vibrated and fluidized. The injectors transport the powder through the hoses to the guns (8). The guns spray the powder/air mixture onto the workpieces to be coated.

The powder which does not adhere on the workpieces falls to the booth floor and is sucked to the cyclone separator (2) as powder/air mixture.

In the cyclone separator, the powder is separated by the influence of centrifugal force. The separated powder is cleaned in the integrated sieve (3) and transported back to the powder container in the OptiCenter by a dense phase conveyor (4), where it is available again for the coating process.

The rest of the non-separated powder (most of it is fine particles) goes into the After Filter (5). The After Filter separates the powder into a refuse container (6), which is positioned directly under the filter elements and is very easy to empty. Then, the cleaned air leaves the filter and is fed directly back into the workshop environment.

Booth – superstructure

The MagicCylinder booth superstructure is a double walled plastic panel construction, forming a side section and a half roof on each side. Horizontal spacing ribs guarantee high stability of the booth walls, and the necessary distance between the inner and outer liners for an optimum powder repelling effect.

All grounded parts, including the booth superstructure supports, are positioned at the necessary required distance outside of the booth. This ensures the powder repelling effect of the booth, also for a longer coating period.

The interior of the booth is illuminated by lightings, which are fitted into the booth ceilings.

The basic version of the MagicCylinder booth has no manual touch-up stations. The booth can be equipped either on one or both sides with manual coating equipment, as precoating or touch-up station alternatively.

Booth – basement

The booth basement is funnel-shaped, with a central suction opening made of reinforced plastic material.

Oversprayed powder depositing in the funnel is blown down into the central suction unit.



MagicCylinder – Basement

Exhaust air system with After Filter

An efficient exhaust air system is used to keep the area around the booth clean and to prevent explosive powder/air mixtures. The exhaust air is created by the fan in the After Filter.

Detailed information about the After Filter is found in the corresponding operating manual.

Fire protection

For safety reasons, it is recommended to equip the plant with a CO₂ fire extinguishing system. An existing fire protection is merged in the security concept of the plant and assumes the plant interlocking release.

Cleaning operation mode

During the automatic gun cleaning, the work piece entrance and exit door are closed, thereby an increased air inlet speed results at the remaining openings at the booth.

This ensures a dust-free environment around the booth during the color change procedure.

Powder recovery

A safe and clean powder recovery is ensured by following components:

- Cyclone separator
- Sieve machine
- Dense phase conveyor
- OptiCenter

The powder which does not adhere on the workpiece (overspray) is fed from the central suction opening in the funnel, through a pipe, to the cyclone intake. The powder is separated in the cyclone and then sieved in the sieve machine. The recovered powder is fed by the dense phase conveyor to the OptiCenter and back into the powder container.



NOTE:

Further information about the powder recovery components you will find in the corresponding user manuals!

Automatic guns

OptiGun-AX or PG 2-AX automatic powder gun types are used in the MagicCylinder powder coating booth. These guns were particularly developed for an automatic, simple cleaning.



MagicCylinder – Automatic guns

The connections for the powder hose, the high voltage and the electrode rinsing air are outside of the coating booth. These supply attachments are integrated into the gun, enabling the guns to can be cleaned automatically by blow-off nozzles.

The powder hose connection makes possible a perfect fixing of the powder hose by the clamping device. This is a prerequisite for the automatic rinsing of the powder transport equipment (further information about automatic guns, see in the corresponding user manual).

On the MagicCylinder booth, a distinction between light and dark colors is principally made. As a result of this, the powder hoses are double placed from the OptiCenter.

Cleaning the guns

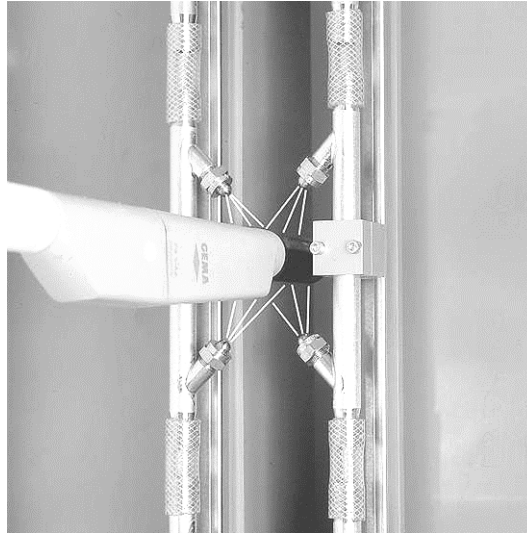

MagicCylinder – Cleaning the guns

The automatic guns are cleaned very simply and quickly. The cleaning of the automatic guns takes place by the gun blow off equipment on the MagicCylinder coating booth.

By activating the cleaning function on the control unit, the reciprocators and the guns move out of the booth. At the same time, each gun is blown off cleanly from the outside, by four flat jet blow-off nozzles.

These flat jet blow-off nozzles are found on the gun slots, on the outside of the booth. If necessary, this cleaning sequence can be repeated.

Technical data

MagicCylinder powder coating booth

Electrical data

MagicCylinder	
Input voltage	3x400 V / 50 Hz (other voltages and frequencies on request)

Pneumatic data

MagicCylinder	
Input pressure	min. 6 bar / max. 10 bar
Air entry speed	0.7 m/sec
Water vapor content of compressed air	max. 1.3 g/m ³
Oil content of compressed air	max. 0.1 mg/m ³

Dimensions

MagicCylinder	
Booth diameter	2.5 m (in the interior)
Booth basement height	1,2 m
Weight: with superstructure height 3000 mm	approx. 2600 kg
more or less weight per 500 mm height:	approx. 300 kg

Sound pressure level

MagicCylinder	
Sound pressure level	max. 80 dB(A) in coating operation

The sound pressure level was measured while the unit was in operation; measurements were taken at the most frequent operator positions and at a height of 1.7 m from the ground.

The specified value is applicable only for the coating booth itself and does not take into account external noise sources or cleaning impulses.

The sound pressure level may vary, depending on the booth configuration and space constraints.

Commissioning

Set-up and assembly

Installation

Installation work to be done by the customer must be carried out according to local safety regulations!

Cable connections / junctions

The connecting cables between control unit and guns must be laid out in such a way that they cannot be damaged during operation. Observe the safety regulations!

Grounding

The booth grounding is to be checked at every start-up. The grounding connection is customer specific and fitted on the booth basement, the cyclone separator and the filter housing.

Operation

Before switching on the booth

- Strictly observe the safety regulations (see also chapter "General safety regulations")
- Check the grounding of the booth and the other plant units and ensure it, if necessary
- If necessary, carry out a function check before starting work

After long stops/standstills

1. Fill in or refill powder
2. Check the tight seating of the filter cartridges
3. Place the refuse container under the After Filter

Switch on the booth

1. Open the compressed air supply and set the input pressure for the After Filter
2. Turn on the main switch (the main switch is located on the control cabinet)
3. Turn the key switch, the control unit is activated, the operating unit is activated and the key switch returns to its starting position.
4. Start the system, the main menu appears on the operating unit, the fan in the OptiCenter runs up
5. Activate the OptiCenter (see therefore the corresponding user manual)

Switching off the booth

1. Quit the automatic operation mode
2. Switch off all additional plant units
3. Switch off the system in the main menu
4. Switch off the OptiCenter
5. Switch off the main switch

Alarm messages

If malfunctions take place, the signal horn sounds and an alarm message is shown (see the chapter "Troubleshooting" and the control unit user manual).

Filter cleaning

The filter cartridges in the After Filter are blown off cyclically from the inside during operation. The predetermined cycle times are set at the factory, but must be reset if the maximum differential pressure is repeatedly exceeded (this initiates an alarm).

The differential pressure is displayed on the pressure gauge:

- Pressure monitoring on the filter – is only displayed optically on the pressure gauge
- Pressure monitoring on the fan – is displayed optically and the alarm is initiated by 2 manostats (optically and acoustically)

The upper limiting value, by which the alarm is initiated, is plant-specific and is set by our trained service personnel when assembling the booth.

The setting of the cycle times must be done only by trained service personnel. The input is entered directly on the operating unit of the plant control (see also the operating manual of the plant control unit).

Color change and cleaning

The color change can begin, when the last workpieces have left the booth. In automatic operation mode, the coating is stopped automatically.

Following, a step by step description of the color change procedure from bright to dark (or vice versa) is given. A prerequisite for a quick and efficient color change is that it is done by 2 people, so that some of these steps can be carried out simultaneously.

1. Prepare the booth for cleaning
 - The booth must be empty of hangers
 - Close the booth doors
 - Switching over the booth control to cleaning operation
 - Move the guns to the cleaning position
2. Prepare the OptiCenter for cleaning
 - Remove the powder container from the OptiCenter (the recovery hose remains on the powder container)
 - Set the OptiCenter to the cleaning mode
 - Coarse cleaning of the OptiCenter
3. Clean the guns externally and move them to the blow off position
4. Blow off (internal cleaning) the powder hoses in direction from the OptiCenter

5. Coarse cleaning of the booth
 - Coarse cleaning of the booth with the air lance
 - Open the cyclone cone and remove the sieve, leave the cyclone open
 - Remove the recovery hose from the powder container
6. Clean the booth
 - if necessary, move the guns out of the booth
 - if necessary, clean the muzzles etc.
 - Blow off the booth with the air lance, clean the suction opening
 - if necessary, wipe off the booth walls
7. Clean the OptiCenter
 - if necessary, change the powder hoses (bright/dark)
 - Initiate the filter cartridges cleaning manually
 - Clean the OptiCenter
8. Clean the recovery system
 - Connect the recovery hose to the blow off connector
 - Open the cyclone cone and clean the sieve
 - Blow off the recovery system
 - if necessary, wipe off the cyclone cone
 - Blow off the inside of the monocyclone with the air lance
9. Prepare the equipment for coating
 - Make the recovery system ready for operation
 - Put the OptiCenter into coating operation
 - Put the booth into coating operation (switch on the plant, move the XT axis into coating position, start the correct reciprocators program)
10. Check the guns for functioning (high voltage and powder output)



NOTE:

This short instructions should facilitate, above all, the handling of the plant for the daily, always recurring works. They do not replace by any means the enclosed manuals of the components, and presuppose that you read and understand the corresponding chapters in the operating manual as well as the safety regulations.

Maintenance

Maintenance and repair

Daily or after each shift

- Blow off the powder hoses
- Clean the guns externally and the check wearing parts
- Check the vibrating sieve of the cyclone separator and clear away contamination with an industrial vacuum cleaner

Weekly

(in single-shift works, or in each fifth shift in multi-shift works)

- Check the clean air chamber in the After Filter housing for powder deposits through the inspection window of the filter housing above the door. If powder deposits are present, this is an indication of defect filter elements (replace the filter elements, see After Filter operating instructions).
- Check all oil separators and if necessary, empty (if oil is present, the compressed air preparation must be checked)

Biannually

- Disconnect the measuring lines of the pressure gauges on the manometer, and blow it off from the manometer to the measuring point (beginning of the line). Definition of the lines: H = high, L = low.



NOTE:

**The indicated blowing direction is absolutely to be observed!
The parts to be replaced during maintenance are available as spare parts, see the spare parts list!**

Maintenance and repair of the cyclone separator

The following activities on the cyclone should be carried out regularly:

- Remove powder deposits and caked powder
- Check the gaskets, sealing strips and locking mechanisms (covers etc.) for functioning and sealing
- Replace the material abraded from the cyclone inside walls by abrasive powders (by build-up welding)

Further information, see the corresponding operating manual!

Maintenance and repair of the sieve machine

The following activities on the sieve machine should be carried out regularly:

- Check the gaskets and if necessary, replace them
- Clean the sieve mesh, or if damaged, replace it

Further information, see the corresponding operating manual!

Maintenance of the After Filter pressure gauges (filter and fan)

The following check should be carried out regularly:

- Notice the pressure on the pressure gauges and compare with the original pressure values, which were set by the Gema service engineer at the first start-up
- If errors arise, see the troubleshooting guide and the After Filter operating instructions
- If it is not possible to adjust the original settings, please contact an Gema service center

Further information, see the corresponding operating manual!

Replacing spare parts

Spare parts are to be replaced by trained personnel only. The plant must always be switched off, when replacing spare parts. Spare parts can be ordered from the spare parts list.



NOTE:

Only original Gema spare parts should be used!

Functional check

General information

A function check is to be carried out:

- after a replacement of spare parts on the booth or on the electrical part of the booth, or on plant units connected to the booth
- after manipulations on the electrical part, or on external plant units connected to the booth control unit, or on the booth control unit itself
- after long stops/standstills

Procedure of the function check

1. Switch on the main switch, control units and all interlocked equipment should not be able to be switched on
2. Turn the key switch, the control unit is activated, the operating unit is activated and the key switch returns to its starting position. Control units and all interlocked equipment should not be able to be switched on
3. Start the system, the main menu appears on the operating unit
4. The operation of the OptiCenter is described in the corresponding user manual
5. Switch on the gun control units, if necessary
6. Activate the automatic function on the operating unit, the reciprocators move to the reference point. All interlocked plant units are enabled (ES control unit etc.)
7. The control units and all interlocked plant units are ready for operation
8. The message **too little powder** appears on the operating unit after a delay, and the alarm horn sounds

Decommissioning, storage

Introduction

Safety rules

Suitable equipment (e.g. a crane) must be used when moving parts that are sometimes bulky and heavy.

Components being disassembled must be adequately secured before they are detached.

Requirements on personnel carrying out the work

Use only technical personnel who are trained in operating the respective equipment (e.g. a crane).

If there are any uncertainties, please contact Gema.

Storage conditions

Storage duration

If the physical conditions are maintained, the unit can be stored indefinitely.

Space requirements

The space requirements correspond to the size of the booth parts plus the packaging.

The load-bearing capacity of the floor should be at least 500 kg/m².

There are no special requirements concerning distance to neighboring equipment.

Physical requirements

Storage must be inside a dry building at a temperature between +5 and +40 °C. Do not expose to direct sunlight.

Hazard notes

There is no danger to personnel or the environment if the unit is stored properly.

Shut-down

Decommissioning

Before starting any kind of work, the whole plant must be disconnected from the supply (current/compressed air).

The fire suppression components connected to the booth are to be dismantled/removed according to the instructions of the fire detection system supplier.

Cleaning

Remove the contamination from the outside of all components.

Disassembly/attachment of transport safety devices

- use supplied transport utilities again

Packing

A suitably stable pallet, big enough, must be used. To prevent damage to the components, collisions with other parts must be prevented.

It is definitely not recommended to stack the individual parts! Should this nonetheless be planned, the packaging must be made robust enough to protect the booth parts against additional forces.

Identification

Apply the label "Protect from dampness and moisture" on the product and the packaging.

Maintenance during storage

Maintenance schedule

No maintenance schedule is necessary.

Maintenance works

During long-term storage, periodically perform a visual check.

Return to service

Commissioning following storage

Before mounting the booth, make sure that all plastic components such as panels have been "acclimatized" at a room temperature of at least 15 °C for at least 24 hours.



WARNING:

Avoid stress cracks!

Packing, transport

Introduction

This chapter describes special precautions that must be taken during internal transport of the product if:

- the customer himself must pack, transport and ship the product, such as to have renovations or service work carried out by the manufacturer

or

- the product must be shipped for disposal (recycling).

Safety rules

Suitable equipment (e.g. a crane) must be used when moving parts that are sometimes bulky and heavy.

Components being disassembled must be adequately secured before they are detached.

Requirements on personnel carrying out the work

Use only technical personnel who are trained in operating the respective equipment (e.g. a crane).

If there are any uncertainties, please contact Gema.

Packing material

Not necessary for the internal transport. For external transport see "Storage".

Transport

Data concerning goods to be transported

- The space requirements correspond to the size of the components plus the packaging
- Weight see "Technical Data"
- Points of attachment, see "Mode of transportation"

Mode of transportation

For short distances/shifts of position within the same room, parts for the booth must be transported using a forklift truck.

Loading, transferring the load, unloading

Exercise caution at temperatures below +5 to 15 °C.



WARNING:

Avoid stress in the plastic material! The plastic booth must not be transported at temperatures below -15 °C.

In summer, the air temperature during transport should not exceed +60 °C.



WARNING:

Avoid heat accumulations and storage in sunlight.

Suitable lifting equipment is to be used for all procedures.

Troubleshooting

General information



WARNING:

Faults may be fixed by trained personnel only!

Malfunctions, which arise during operation, are registered together with emergency stops in a list with date and time indications. An error message is displayed on the operating unit of the control unit.

If a fault arises, the plant is not stopped. However, if an emergency stop arises, the whole plant (or units) is switched off and the emergency stop mask is displayed on the operating unit.

The alarm horn sounds at the same time with every message (malfunction or emergency stop).

Problem fixing

Problem/error/malfunction	Procedures/remedy
Alarm has been released: Message too little powder bright (dark) Display flashes in the OptiCenter Powder shortage in the powder container	Acknowledge error, fill in fresh powder Switch off the alarm, fill in fresh powder
Alarm has been released: Message EMERGENCY STOP protective switch Motor malfunction exhaust air fan, corresponding motor protection switch has reacted	Let the motor cool down, switch on the corresponding motor protection switch again (see wiring diagram), see also the "Troubleshooting" section in the After Filter operating manual. In the case of repeated alarm, contact your Gema service center

Problem/error/malfunction	Procedures/remedy
<p>The pressure increase is indicated on the filter manometer</p> <p>Pressure increase on the filter cartridges</p>	<p>Switch off the gun control units, wait until the differential pressure returns to normal again. Check the cleaning cycles by ear, if necessary, shorten the pause times in the cleaning cycle. Check, if the cleaning pressure is set on 5 bar on the pressure input valve (see also the section "Troubleshooting" in the After Filter operating manual)</p> <p>WARNING: If the pressure gauge shows a pressure rise higher than 3 kPa, contact your Gema agent immediately!</p>
<p>Alarm has been released:</p> <p>Message Fan overpressure</p> <p>Minimum pressure in filter housing not reached – corresponding pressure gauge responding</p>	<p>Too little pressure, too much exhaust air, because too little or no air resistance</p> <p>Filter housing door is open</p> <p>Sieve machine not fitted tightly on the cyclone separator</p> <p>Waste container not fitted tightly (see also the troubleshooting section in the After Filter manual)</p>
<p>Alarm has been released:</p> <p>Message Fan low pressure</p> <p>Maximum pressure in the filter housing exceeded – corresponding pressure gauge responding</p>	<p>Pressure too high, insufficient exhaust air because the air resistance is too high</p> <p>Filter clogged (valves defect or cleaning pressure too low, at least 5 bar)</p> <p>Poor compressed air quality (contains oil or water)</p> <p>Malfunctions on running-in, until the filter cake is built up on the filter cartridges (see also the "Troubleshooting" section in the After Filter operating manual)</p>
<p>Alarm has been released:</p> <p>Message Guns not OK</p> <p>Diagnostic adaptor of the guns indicates, that no high voltage is being produced</p>	<p>Turn on the gun control unit, or correct the fault in the gun control unit or gun with the information in the corresponding operating instructions</p>

Problem/error/malfunction	Procedures/remedy
Bad separation efficiency of the cyclone	<p>Check all gaskets, above all, on the powder separation of the cyclone and if necessary, repair them</p> <p>Check the exhaust air volume flow, if necessary, clear blocked tubes or repair the After Filter</p> <p>Check the cyclone casing for holes, caused by wear</p> <p>Check the pretension force of the closings</p>
Sieve clogged up	<p>Check the powder for dampness</p> <p>Check, if too much powder was fed through the cyclone, e.g. during the booth cleaning</p>
Automatic floor blow-off system not OK	<p>Check the compressed air supply</p> <p>Pressure reducing valve defective or adjusted incorrectly</p> <p>Solenoid valve defective (coil, cable) or missing signal</p>

Setting values



NOTE:

The setting values for the OptiCenter and other plant units you will find in the corresponding operating instructions!

Spare parts list

Ordering spare parts

When ordering spare parts for powder coating equipment, please indicate the following specifications:

- Type and serial number of your powder coating equipment
- Order number, quantity and description of each spare part

Example:

- **Type** MagicCylinder
Serial number 1234 5678
- Order no. 203 386, 1 piece, Clamp – Ø 18/15 mm

When ordering cable or hose material, the required length must also be given. The spare part numbers of this bulk stock is always marked with an *.

Wearing parts are always marked with a #.

All dimensions of plastic hoses are specified with the external and internal diameter:

Example:

Ø 8/6 mm, 8 mm outside diameter (o/d) / 6 mm inside diameter (i/d)



WARNING!

Only original Gema spare parts should be used, because the explosion protection will also be preserved that way. The use of spare parts from other manufacturers will invalidate the Gema guarantee conditions!

MagicCylinder – Spare parts list

1	Fluorescent tube – 200-240 V, 50 Hz, 18 W	1004 542
2	Fluorescent tube – 200-240 V, 50 Hz, 36 W	1004 543
3	Door drive unit (see separate spare parts list)	
4	Gun blow off equipment (see separate spare parts list)	
5	Fan control unit (see separate spare parts list)	

MagicCylinder – Spare parts

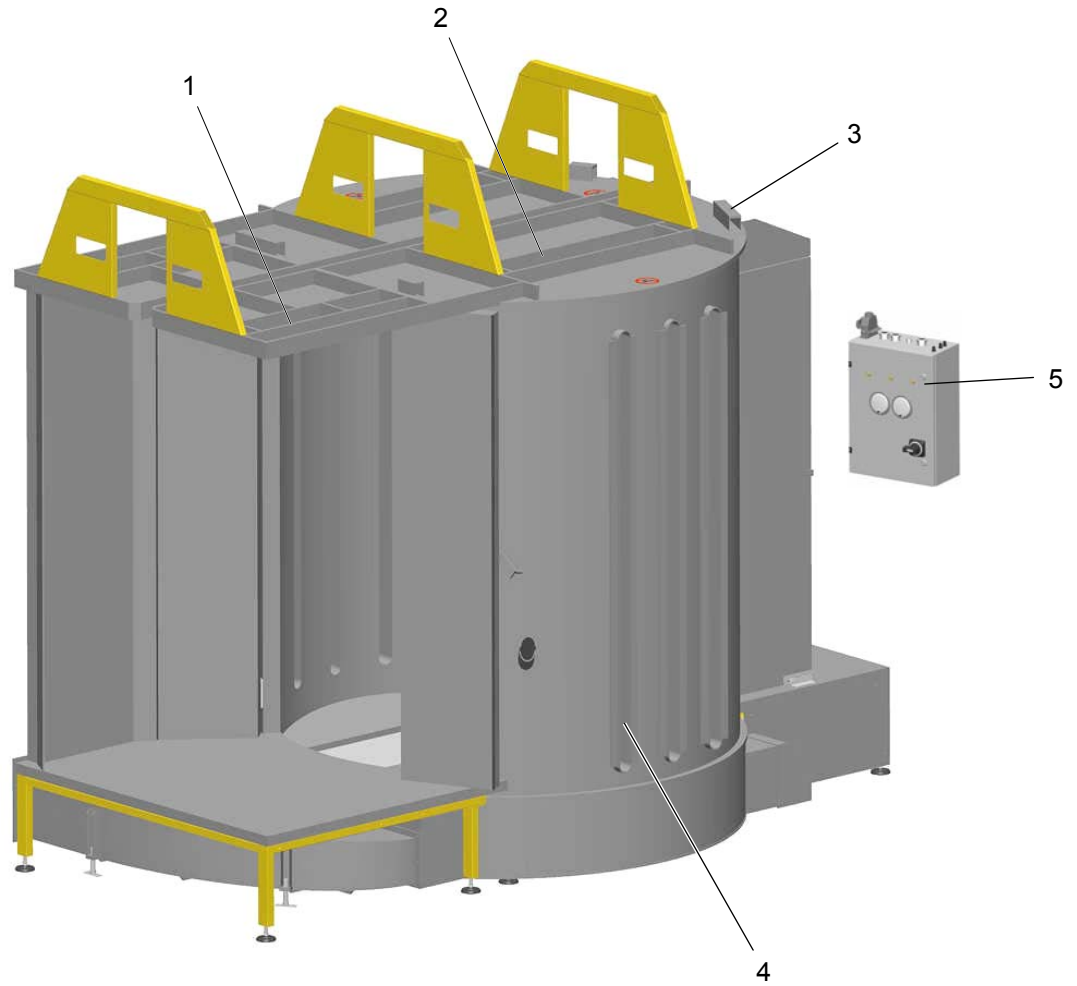

MagicCylinder – Spare parts

MagicCylinder – gun blow off equipment

1	Intermediate piece – complete	381 110
2	End piece – complete	381 160
3	Tube – Ø 18/16 mm (distance between nozzles)	381 144
4	Tube – Ø 18/16 mm, L=1950 mm	381 152
13	Hose clamp – Ø 17-25 mm	223 085
14	Plug cap – 1"	243 612
15	Plug cap – 1/2"	259 306
16	Hose connector – Ø 17 mm, 1/2"	223 069
17	Y-piece – 1/2"-1/2"-1/2"	267 171
18	Double nipple – 1"-1"	1003 544
19	Adapter nipple – 1"-1/2"	252 875
20	Ball valve – 1", 1/1	1003 546
21	Solenoid valve	1003 547
23	Compressed air hose – Ø 16.4/26.6 mm, black	105 155*
24	Cable socket – 3 pins, with female connectors	227 919
25	Allen grub screw – M6x10 mm	214 841
26	O-ring – Ø 18x2 mm	244 287#
27	Flat jet nozzle	250 716
28	Nozzle nut	250 724

* Please indicate length

Wearing part

MagicCylinder – gun blow off equipment

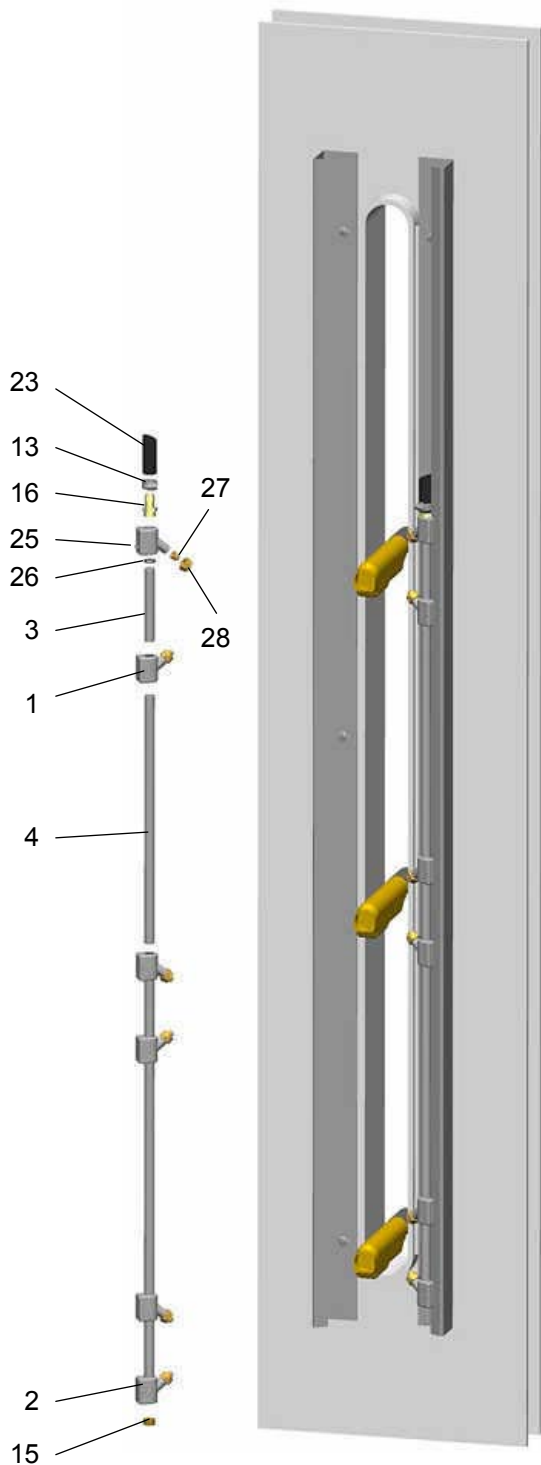

Version with control valve

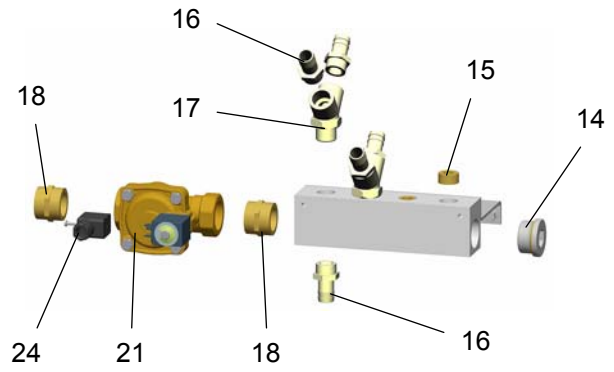

Manual control version

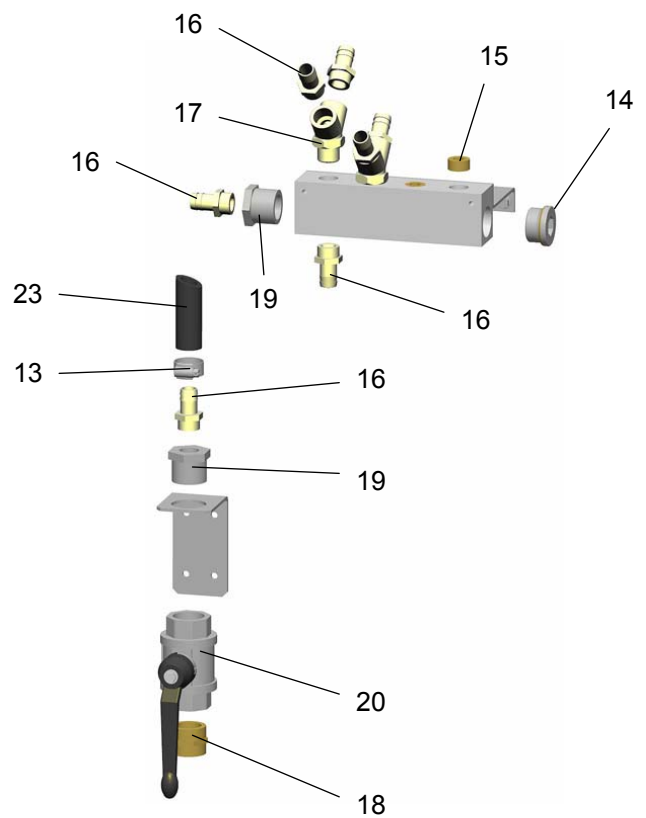

MagicCylinder – gun blow off equipment

MagicCylinder – door drive unit

1	Holder – large	389 714
2	Holder – small	389 706
3	Drive shaft	1000 128*
4	Coupling	389 730
5	Hinge	373 770
6	Rotary actuator	389 790
7	Lever	389 749
8	Support	389 722
13	Connection case – complete	373 885
15	Cable – 7x0.75 mm ²	100 536
16	Cable – 4x1 mm ²	100 579
17	Valve cable – L=0.7 m	373 605
18	Proximity switch	246 760
21	Throttle check valve	266 825
23	Solenoid valve – 5-1/8", 220 VAC	259 705
24	Inline regulator – 6 bar	263 320
27	Silencer – 1/8"	251 305
30	Double nipple – 1/8"-1/4"	242 209
32	Y-connection fitting – 1/8", Ø 8 mm	253 936
33	Adjusting elbow – Ø 8/8 mm	238 287
35	Elbow joint – 1/4", Ø 8 mm	254 029
39	Plastic tube – Ø 8/6 mm, black, antistatic	103 756
40	Rubber buffer – Ø 40x28 mm, M8a	248 592
41	Hexagon screw – M5x10 mm	205 699
43	Hexagon shakeproof screw – M6x12 mm	244 406
45	Hexagon shakeproof screw – M8x20 mm	244 422
46	Allen cylinder screw – M4x20 mm	216 291
47	Allen cylinder screw – M4x16 mm	216 283
48	Cap screw – M5x35 mm	201 715
50	Hexagon nut – M4	205 192
51	Hexagon nut – M5	205 150
55	Lock washer – M4	205 680
56	Lock washer – M5	205 168
57	Washer – Ø 5.3/10x1 mm	205 320
58	Allen grub screw – M4x8 mm	214 736
59	Coiled spring pin – Ø 4x20 mm	259 683

* Please indicate length

MagicCylinder – door drive unit

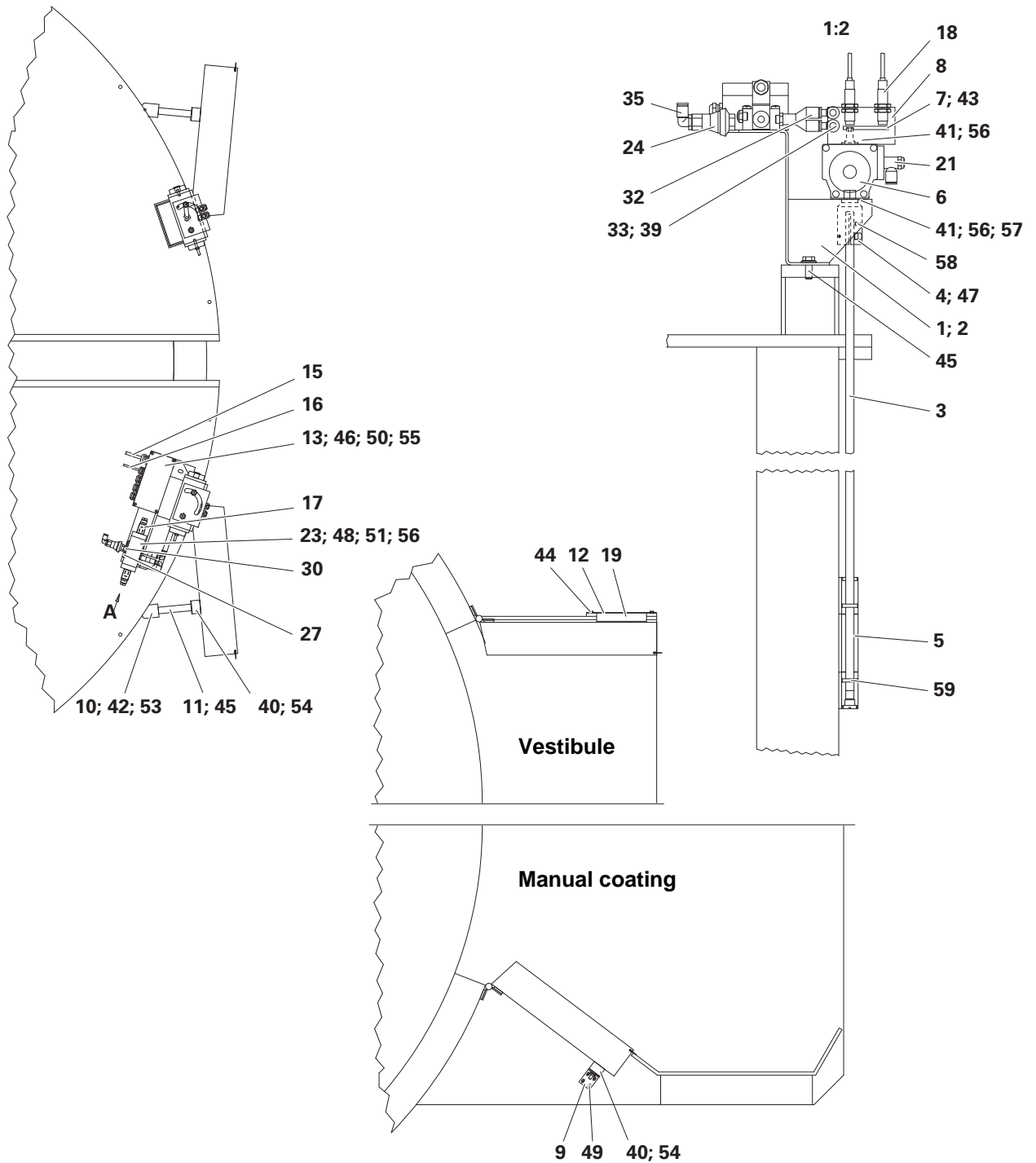

MagicCylinder – door drive unit

MagicCylinder – Fan control unit

	Fan control unit – complete	see table
4	Plastic tube – Ø 6/4 mm	103 144#
6	Locknut – M20x1.5 mm	266 035
7	Locknut – M40x1.5 mm	265 357
8	Cable connection – M20/1/8-15 mm	266 019
9	Cable connection – M40/1/28.5-33 mm	265 349
10	Elbow joint – 6-1/8"-6 mm	245 950
11	Elbow joint – 1/8"-Ø 6 mm	254 061
12	Adjusting elbow – Ø 6/8 mm	237 990
13	Lead-through connection – Ø 8/8 mm	253 880
14	Switch – 0,75-5,6 kPa	243 744
	Switch – 1.25-11.0 kPa	243 752
15	Pressure gauge – 0-5.0 kPa, differential pressure	243 779
16	Pressure gauge – 0-8.0 kPa, differential pressure	251 844
20	Main switch – see corresponding wiring diagram	
21	Connecting socket/plug – see corresponding wiring diagram	

Wearing part

Order number	Motor performance (kW)	Pressure gauge (kPa)	
		Filter (pos. 15)	Fan (pos. 16)
1002 205	22	5.0	8.0
1002 174	30	5.0	8.0
1002 175	37	5.0	8.0
1002 176	45	5.0	8.0
1002 177	55	5.0	8.0

MagicCylinder – Fan control unit

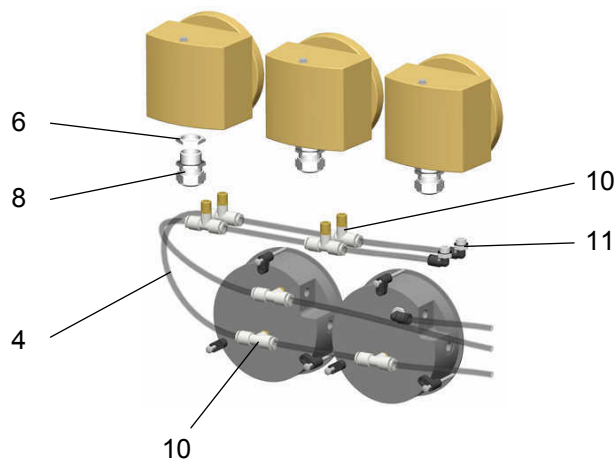
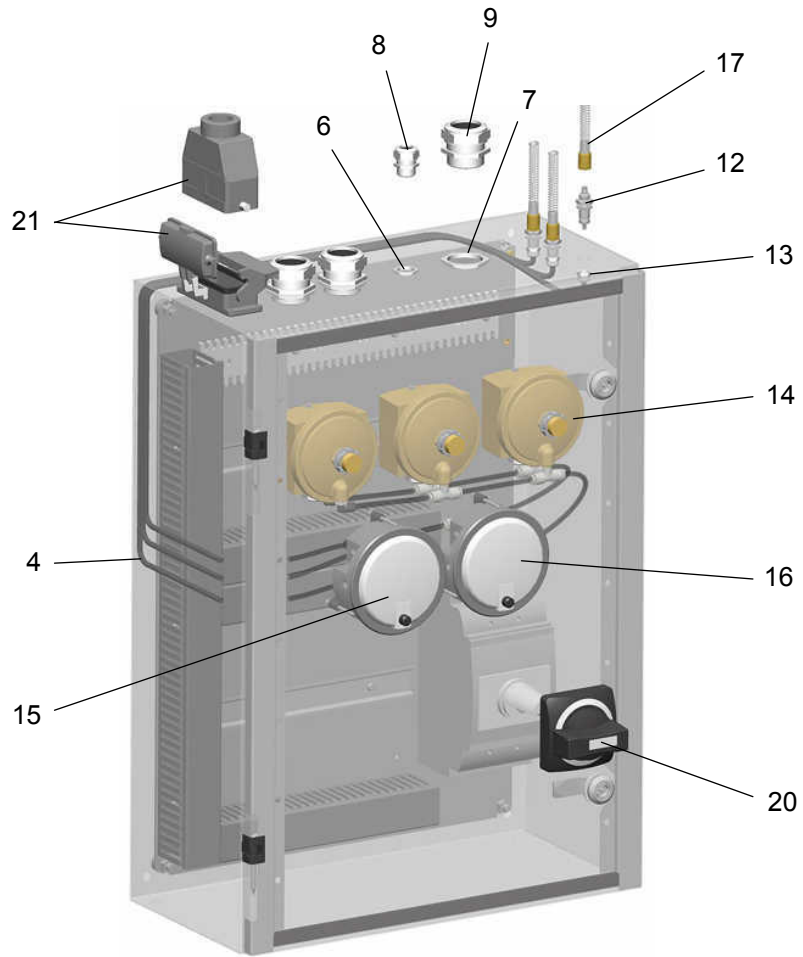

MagicCylinder – Fan control unit