



**GigaOhm 1kV**  
**MI 3103**  
**User Manual**  
*Version 1.3, Code No.20 750 842*

*Distributor:*

*Manufacturer:*

METREL d.d.  
Ljubljanska cesta 77  
1354 Horjul  
Slovenia

web site: <http://www.metrel.si>

e-mail: [metrel@metrel.si](mailto:metrel@metrel.si)



Mark on your equipment certifies that this equipment meets the requirements of the EU (European Union) concerning safety and interference causing equipment regulations

© 2005 METREL

No part of this publication may be reproduced or utilized in any form or by any means without permission in writing from METREL.

---

<b>1. General introduction</b>	<b>4</b>
1.1 Features	4
1.2 Applied Standards	4
<b>2. Instrument description</b>	<b>5</b>
2.1 Instrument casing	5
2.2 Operator's panel	5
2.3 Connectors	6
2.4 Bottom section	7
2.5 Accessories	7
<b>3. Warnings and instrument messages</b>	<b>8</b>
3.1 Warnings	8
3.2 Instrument messages	9
<b>4. Measurements</b>	<b>10</b>
4.1 Insulation resistance	10
4.2 $R_{\pm 200mA}$	11
4.3 $R_{con}$	13
4.4 Compensation of test leads resistance	14
4.4 Voltage measurement	14
<b>5. Maintenance</b>	<b>15</b>
5.1 Inspection	15
5.2 Battery replacement	15
5.3 Fuse replacement	16
5.4 Cleaning	16
5.5 Service	16
<b>6. Specifications</b>	<b>17</b>
6.1 Measurements	17
6.2 General specifications	19

# 1. General introduction

## 1.1 Features

The **GigaOhm 1kV** is a portable hand-held battery powered test instrument intended for testing of safety measures on mains installations.

The equipment is designed and produced with the extensive knowledge and experience acquired through many years of dealing with electrical installation test equipment.

General functions of the **GigaOhm 1kV**:

- Insulation resistance measurement,
- Continuity measurement using test current of 200 mA in accordance with EN 61557-4 standard,
- Continuity measurement (continuous measurement) using test current of up to 7 mA,
- AC / DC voltage measurement.

Features:

- Insulation resistance test voltages: 250 V DC, 500 V DC, 1000 V DC,
- Automatic discharge of tested item after measurement completion,
- Automatic test voltage polarity exchange in Continuity  $\pm$  200 mA function,
- Rcon 7 mA function for inductive test items.

A custom designed LCD offers easy to read results. Operation is simple and clear, the operator does not need any special training (except reading and understanding this User Manual) to operate the instrument.

In order for the operator to be familiar with measurements in general, it is advisable to read the handbook **Measurements on electric installations in theory and practice**.

## 1.2 Applied Standards

Instrument operation: IEC / EN 61557-1, IEC / EN 61557-2, IEC / EN 61557-4,  
IEC / EN 61557-10  
*BS 7671 – 16<sup>th</sup> edition*

Electromagnetic compatibility (EMC): IEC 61326 Class B

Safety: *EN/IEC 61010-1 (instrument),  
EN/IEC 61010-2-31 (accessories)*

## 2. Instrument description

### 2.1 Instrument casing

The instrument is housed in a plastic casing, which maintains the protection class defined in general specifications.

### 2.2 Operator's panel

The operator's panel consists of a custom LCD, a rotary switch, and a keyboard, see the figure below.

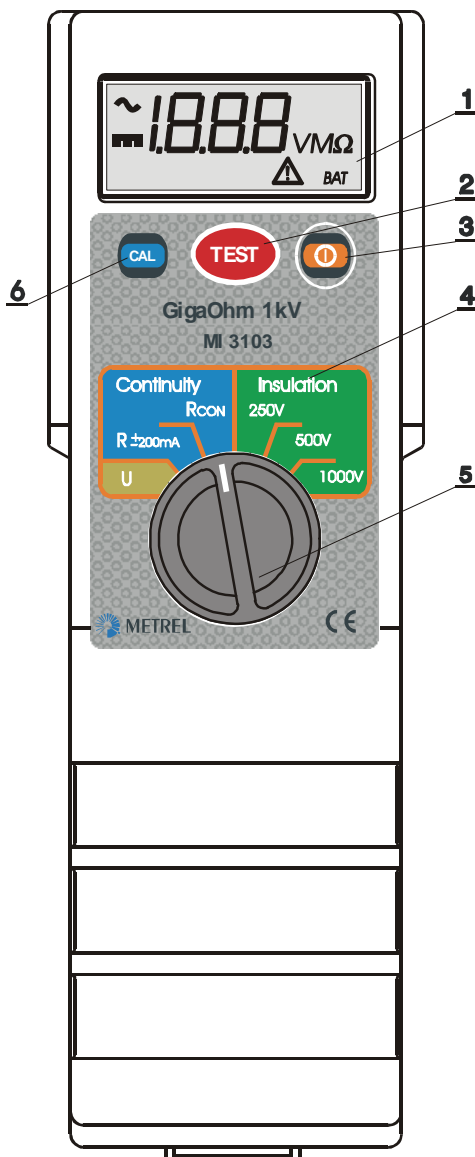

**Fig. 1.** Front panel

**Legend:**

- 1..... Display.
- 2..... **TEST** key to start any measurement.
- 3     **ON / OFF** key. The instrument is automatically switched off if no action (changing rotary switch position or pressing any key) is taken for more than 10 minutes.
- 4..... Front label.
- 5..... Rotary switch to select measurement function.
- 6..... **CAL** key to compensate resistance of the test leads.

## 2.3 Connectors



- *Use original test accessories only!*
- *Max. allowed voltage between mains test terminals and ground is 300 V!*
- *Max. allowed voltage between mains test terminals is 600 V!*
- *Max. output voltage between test terminals is 1200 V!*

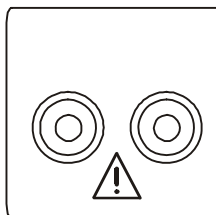

**Fig. 2. Connectors**

## 2.4 Bottom section

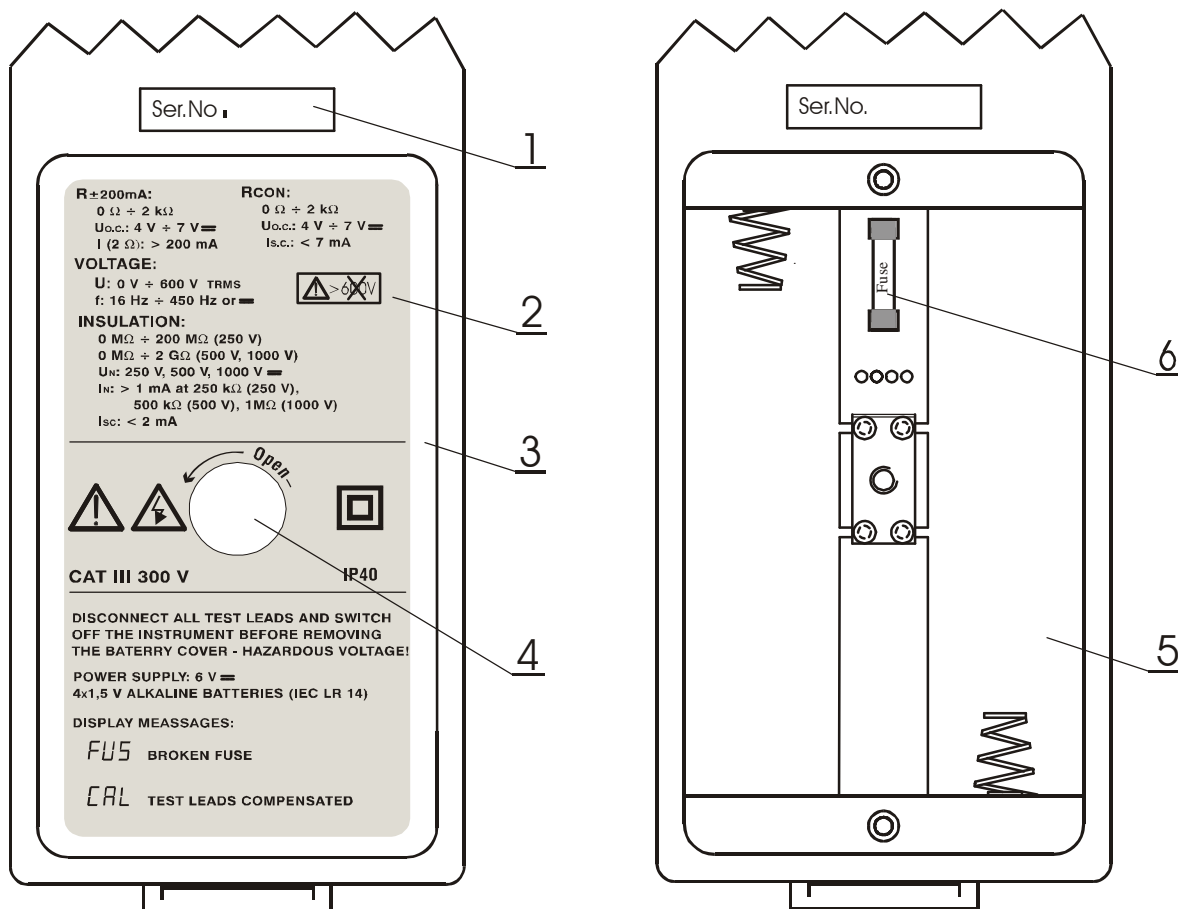

**Fig. 3. Bottom section**

### Legend:

- 1..... Serial number.
- 2..... Information label.
- 3..... Battery cover.
- 4..... Screw to fix battery cover.
- 5..... Battery holder.
- 6..... Fuse.



## 2.5 Accessories

The instrument set consists of standard and optional accessories. Optional accessories can be delivered upon request. See attached list for standard configuration and options or contact your distributor or see the METREL home page: <http://www.metrel.si>.

## 3. Warnings and Instrument messages

### 3.1 Warnings

In order to reach the highest level of operator's safety while carrying out various measurements and tests using the **GigaOhm 1kV**, as well as to ensure the test equipment remains undamaged, it is necessary to consider the following general warnings:

- **If the test equipment is used in a manner not specified in this User Manual, the protection provided by the equipment may be impaired!**
- **Do not use the instrument and accessories if any damage is noticed!**
- **In case of blown fuse, follow the instructions in this Instruction Manual to replace it!**
- **Service intervention or adjustment procedure is allowed to be carried out only by a competent, authorised person!**
- **Consider all generally known precautions in order to avoid risk of electric shock while dealing with electrical installations!**
- **Use only standard or optional test accessories supplied by your distributor!**
- **Do not connect test terminals to an external voltage higher than 600 V AC or DC in order not to damage the test instrument!**
-  **symbol at the instrument means "Read the User Manual with special care!" The symbol requires an action!**
-  **symbol on LCD indicates an irregular condition of the tested item which may present a hazardous live voltage.**
- **Disconnect all test leads and switch power off before opening battery cover!**
-  **symbol means that the instrument output can be higher than 1000V during insulation test. Especially take care when measuring capacitive loads.**



### 3.2 Instrument messages

Messages are generated on the LCD using special symbols and numeric segment combinations. The next figure shows all possible display segments and the table under the figure describes the messages.

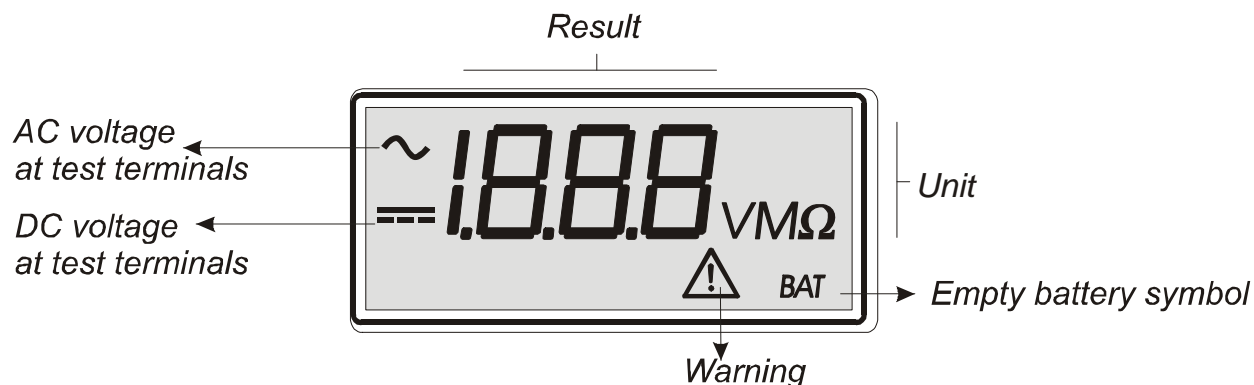

**Fig. 4.** Display segments

Description of possible display messages:

<b><i>o.r.</i></b>	<i>Result is out of range.</i>
<b><i>CAL</i></b>	<i>Test leads are compensated.</i>
<b><i>FUS</i></b>	<i>Blown fuse (in <math>R_{\pm 200mA}</math> and <math>R_{con}</math> functions only).</i>
<b><i>BAT</i></b>	<i>Message before the instrument is switched off because of empty batteries</i>

**Table 1.** Display messages

## 4. Measurements

### 4.1 Insulation resistance

#### Warnings!

- Make sure that the item to be tested is disconnected (mains voltage disconnected) before starting the insulation resistance measurement!
- When measuring insulation resistance between conductors, all loads must be disconnected and all switches closed!
- Do not touch tested item while the test is in operation, risk of electric shock!
- In case of capacitive test item (capacitive compensation of reactive power, long tested cable, etc.) automatic discharge of the item may not be done immediately after finishing the measurement. Falling voltage will be displayed in that case – do not disconnect test leads until the voltage drops below 30 V! Measurement is finished when voltage drops below 8V.

The following figure shows connection of the instrument to the tested item for testing insulation resistance on one and three phase electrical installations. The measurement should be carried out between all conductors.

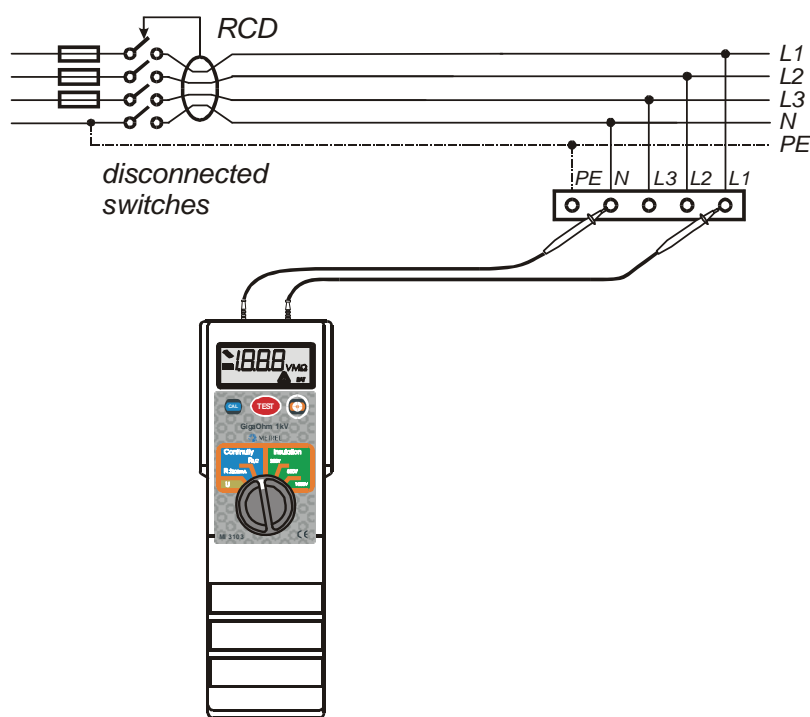

**Fig. 5.** Example of instrument connection for measuring insulation resistance between L and N terminal

There may be also other items to test such as motor windings, ground cables, antistatic floor coatings, walls, etc., see the booklet **Measurements on electric installations in theory and practice**.

**How to carry out the measurement:**

- Select **Insulation resistance** function with appropriate test voltage using the rotary switch knob.
- Connect test leads to the item to be tested in accordance with figure 5.
- Press the **TEST** key and read the displayed insulation resistance result.
- A double press of **TEST** key starts the continuous measurement. The measurement is concluded after pressing **TEST** key again. The latest result will stay on the display.



*Fig. 6. Example of displayed insulation resistance result*

**Notes!**

- If an external voltage higher than 20 V AC/DC is present at the test terminals, the insulation resistance measurement will not be carried out after pressing START key. Symbol  $\triangle$  will be displayed.
- Tested item is discharged automatically after finishing the measurement and the actual voltage is displayed during discharge operation (only if high capacity is present on the test leads).
- Positive pole of test voltage is attached to the red test terminal.

**4.2 R  $\pm$ 200mA**

Continuity of protection conductors is measured before mains voltage is connected to the tested installation (new or adapted installation). Max. allowed resistance value depends on power of connected loads, used installation system (TN, TT), etc.

Test current of at least 200 mA is required by the EN 61557-4 regulation which is why this function has to be used whenever tests are done in accordance with this standard.

For additional general information concerning this measurement refer to the handbook **Measurements on electric installations in theory and practice**.

**Warning!**

- **Make sure that the tested item is de-energised (mains voltage disconnected) before starting the measurement! Fuse will blow if the test probes are connected to the mains voltage during the test.**

**How to carry out the measurement:**

- Select **R ±200mA** function with the rotary switch knob.
- Make sure test leads are compensated, see the instructions in the chapter 4.4.
- Connect test leads to the tested item in accordance with figure 7.
- Press the **TEST** key and read the continuity resistance result.
- A double press of **TEST** key starts the continuous measurement. The measurement is concluded after pressing the **TEST** key again. The latest result will stay on the display.

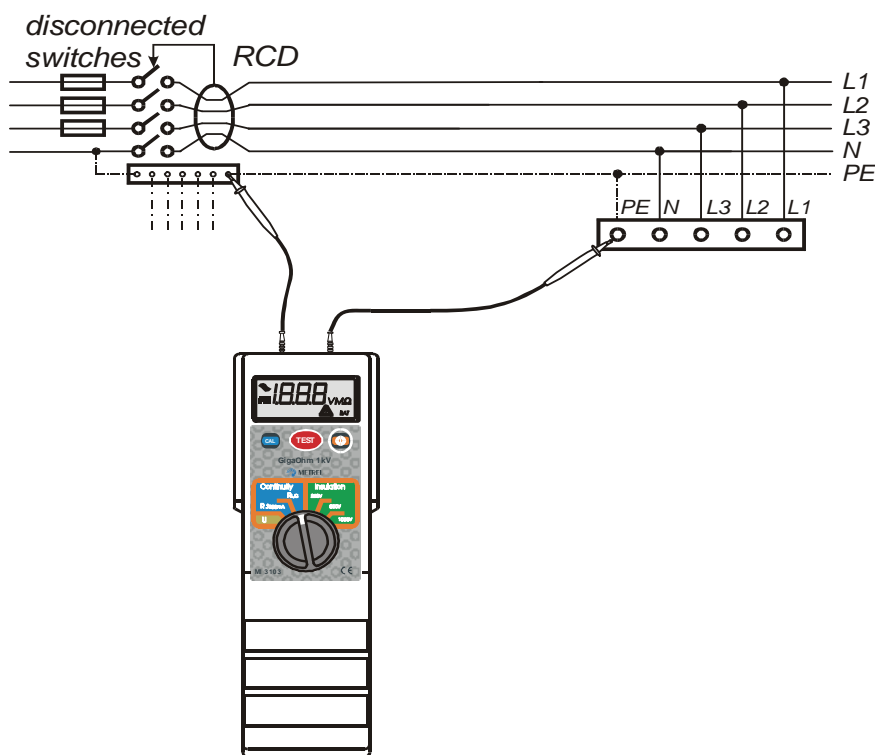

**Fig. 7.** Example of instrument connection for measuring continuity between potential equalizers



**Fig. 8.** Example of  $R_{\pm 200mA}$  test result

**Notes!**

- If an external voltage higher than 10 V AC/DC is present at the test terminals, the **R ±200mA** measurement will not be carried out after pressing the START key. Symbol  $\triangle$  will be displayed.
- If indication **FUS** appears, replace blown fuse with a new one. See the paragraph 6.3. Fuse replacement.

## 4.3 Rcon

Rcon function is used when there are inductive loads to be tested, for example motor windings, transformers, etc, or if there is no need to follow prescribed standards. It can also be used as an ordinary multi-meter (resistance range).

Test current of only up to 7 mA is used.

For additional general information concerning continuity measurement, refer to the handbook **Measurements on electric installations in theory and practice**.

### Warning!

- **Make sure the tested item is de-energised (mains voltage disconnected) before starting the measurement! Fuse will blow if the test probes are connected to mains voltage during the test.**

### How to carry out the measurement:

- Select **Rcon** function with the rotary switch knob.
- Make sure the test leads are compensated, see the instructions in the chapter 4.4.
- Connect test leads to the tested item in accordance with figure 7.
- Press the **TEST** key and read the Rcon resistance result.
- A double press of **TEST** key starts the continuous measurement. The measurement is concluded after pressing the **TEST** key again. The latest result will stay on the display.



*Fig. 9. Example of Rcon test result*

### Notes!

- If an external voltage higher than 10 V AC/DC is present at the test terminals, the **Rcon** measurement will not be carried out after pressing the START key. Symbol  will be displayed.
- If indication **FUS** appears, replace blown fuse. See paragraph 5.3. Fuse replacement.
- Positive pole of test voltage is attached to the red test terminal.

## 4.4 Compensation of test leads resistance

In order to achieve high accuracy of test results it is advised to compensate resistance of the test leads before carrying out **R ±200mA** and **Rcon** measurements. Especially it is advised to compensate test leads whenever the leads are changed for different ones.

Compensation of test leads resistance is stored and is used for both **R ±200mA** and **Rcon** functions.

### How to compensate test leads:

- Select **R ±200mA** or **Rcon** function with the rotary switch.
- Short the test leads.
- Press the **CAL** key, the message 'CAL' is displayed for a while then **0.00 Ω** is displayed. Resistance of test leads is now compensated and the instrument is ready for measurements. A confirmation sound indicates that the new calibration values were accepted successfully.

### Note

- Max. resistance that can be compensated is 5 Ω. If total measured resistance is higher than 5 Ω (e.g. open test leads) then any compensation previously stored is cancelled.
- Compensation remains valid until next compensation or until compensation is cancelled (e.g. by performing the compensation with open test leads).

### Indications that the test leads are compensated

- The message 'CAL' for compensated test leads is displayed for a while when setting **R ±200mA** or **Rcon** with rotary switch.

## 4.4 Voltage measurement

### How to carry out the measurement:

- Select **U** function with the rotary switch knob.
- Connect test leads to the equipment under test.
- Read displayed result (Voltage), see the figure below.



*Fig. 10. Example of voltage measurement result*

### Note!

- Do not connect test leads to a voltage higher than 600 V AC to avoid possible damage of the instrument!

## 5. Maintenance

### 5.1 Inspection

To maintain operator's safety and ensure reliability of the instrument it is good practice to inspect the instrument on a regular basis. Check that the instrument and accessories are not damaged. If any defect is found please consult service centre, distributor or manufacturer.

### 5.2 Battery replacement

The symbol 'BAT' on the lower right corner of the LCD indicates the battery state ( $U_{bat} < 4.5\text{ V}$ ).

If a low battery state is indicated the batteries have to be replaced to ensure accurate measurements.

The instrument is switched off automatically when battery voltage drops down to 4.2 V, **bat** indication is displayed before switching off.

#### Notes!

- **All four cells shall be replaced each time.**
- **⚠ Turn power off and disconnect any measurement accessory connected to the instrument before opening battery cover.**

Nominal power supply voltage is 6 V DC. Use four 1.5 V alkaline cells, type IEC LR14 (dimensions: diameter = 26 mm, height = 50 mm).

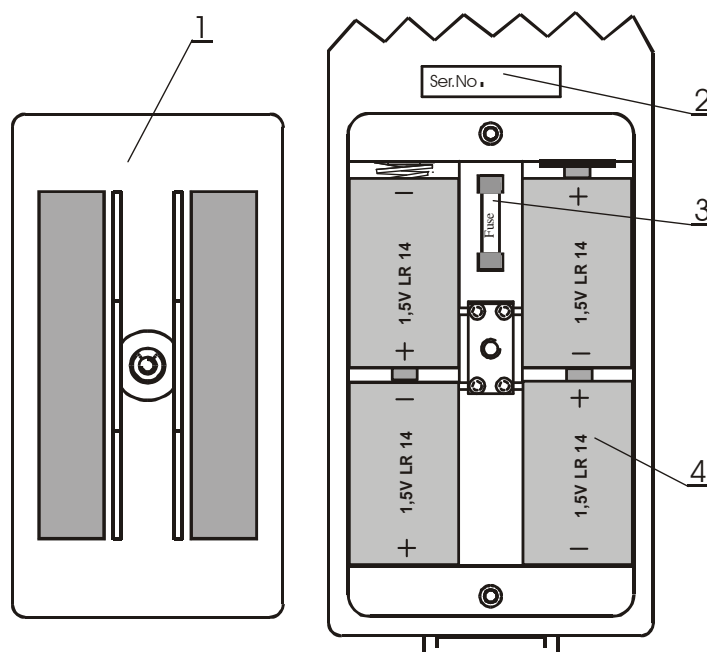

**Fig. 16.** Correct polarity of inserted batteries and fuse position

**Legend:**

- 1..... Battery cover.
- 2..... Serial number.
- 3..... Fuse.
- 4..... Battery.

**Notes!**

- Insert cells correctly, otherwise test instrument will not operate and cells could be discharged, see the figure above for correct battery polarity!
- If the instrument is not used for a long period of time remove all batteries from the battery compartment.

**Warnings!**

- Take into account handling, maintenance and recycling requirements as defined by related standards, national regulations and manufacturer of alkaline batteries.

### 5.3 Fuse replacement

The instrument contains a fuse to protect **R $\pm$ 200mA** and **Rcon** functions. The fuse can blow if an external voltage is connected to the test terminals during the measurement. See the fig. 16. for fuse location.

**Warning!**

- **Replace blown fuse with prescribed one only (M0.315A) otherwise the instrument may be damaged.**
- **⚠ Turn power off and disconnect any measurement accessory connected to the instrument before opening battery cover.**

### 5.4 Cleaning

Use a soft cloth slightly moistened with soapy water or spirit to clean the surface of the instrument and leave the instrument to dry totally, before using it.

**Notes!**

- **Do not use liquids based on petrol or hydrocarbons!**
- **Do not spill cleaning liquid over the instrument!**

### 5.5 Service

Repairs under or out of warranty time: please contact your distributor for further information.

**Note!**

- Unauthorised person is not allowed to open the instrument!



## 6. Specifications

### 6.1 Measurements

#### Insulation resistance

Measuring range according to EN 61557-2 is 0.16 M $\Omega$   $\div$  1999 M $\Omega$  \*

Measuring range Insulation (M $\Omega$ ) Un: 500V, 1000V	Resolution (M $\Omega$ )	Accuracy
0.00 $\div$ 1.999	0.001	$\pm$ (5 % of reading + 5 digits)
2.00 $\div$ 19.99	0.01	
20.0 $\div$ 199.9	0.1	
200 $\div$ 999	1	$\pm$ 10 % of reading
1000 $\div$ 1999	1	$\pm$ 20 % of reading

Measuring range according to EN 61557-2 is 0.17 M $\Omega$   $\div$  1999 M $\Omega$  \*

Measuring range Insulation (M $\Omega$ ) Un: 250V	Resolution (M $\Omega$ )	Accuracy
0.000 $\div$ 1.999	0.001	$\pm$ (5 % of reading + 5 digits)
2.00 $\div$ 19.99	0.01	
20.0 $\div$ 199.9	0.1	
200 $\div$ 999	1	$\pm$ 15 % of reading
1000 $\div$ 1999	1	$\pm$ 25 % of reading

Nominal output voltages: 250 V, 500 V, 1000 V

Output voltage tolerance: -0 %, +20 %

Measuring current: min. 1 mA at 250 k $\Omega$  (250 V), 500 k $\Omega$  (500 V), 1 M $\Omega$  (1000V)

Short circuit current: < 2 mA

Auto discharge after test: yes

Measurement mode: single, continuous measurement

One set of alkaline cells can supply the instrument for more than 70 hours.

#### R $\pm$ 200mA

Measuring range according to EN 61557-4 is 0.16  $\Omega$   $\div$  1999  $\Omega$  \*

Measuring range R $\pm$ 200mA ( $\Omega$ )	Resolution ( $\Omega$ )	Accuracy
0.11 $\div$ 19.99	0.01	$\pm$ (3 % of reading + 3 digits)
20.0 $\div$ 199.9	0.1	
200 $\div$ 1999	1	$\pm$ 5 % of reading

Open-terminal test voltage: 4 V - 7 V DC

Test current for R  $\leq$  2  $\Omega$ : > 200 mA

Compensation of test leads (up to 5  $\Omega$ ): yes

Automatic polarity exchange: yes

Measurement mode: single measurement, continuous measurement

**Rcon**

Measuring range R ( $\Omega$ )	Resolution ( $\Omega$ )	Accuracy
0.0 ÷ 199.9	0.1	$\pm(5\% \text{ of reading} + 3 \text{ digits})$
200 ÷ 999	1	$\pm 10\% \text{ of reading}$
1000 ÷ 1999	1	

Open-terminal test voltage: 4 V - 7 V DC

Compensation of test leads (up to 5  $\Omega$ ): yes

Short-circuit test current: up to 7 mA

Measurement mode: continuous measurement

One set of alkaline cells can supply the instrument for more than 90 hours.

**Voltage U**

Measuring range U (V)	Resolution (V)	Accuracy
0 ÷ 600	1	$\pm(3\% \text{ of reading} + 3 \text{ digits})$

Nominal frequency range: DC, 16 Hz – 450 Hz

Measurement mode: continuous measurement, TRMS

Measuring range in operating conditions.

## 6.2 General specifications

Power supply	6 V DC (4 × 1.5 V alkaline battery IEC LR14)
Typical operating time	>70 h
Auto power off	yes, approximately 10 min of no activity
Dimensions (w × h × d)	280 x 70 x 80 mm
Weight (without accessories)	490 g
Display	custom LCD
Protection classification	Class II (double insulation)
Over-voltage category	CATIII 300 V
Pollution degree	2
Protection degree	IP 40

Reference conditions	
Reference temperature range	10 °C ÷ 30 °C
Reference humidity range	40 %RH ÷ 70 %RH

Operating conditions	
Working temperature range	0 °C ÷ 40 °C
Maximum relative humidity	95 %RH (0 °C ÷ 40 °C), non-condensing

Storage conditions	
Temperature range	-10 °C ÷ +70 °C
Maximum relative humidity	90 %RH (-10 °C ÷ +40 °C) 80 %RH (40 °C ÷ 60 °C)

Accuracies apply for 1 year in reference conditions. Additional error in operating conditions is 1 % of measured value and 1 digit.

Fuses	
Instrument protection	M 0.315 A / 250 V, 5 × 22 mm

