

Serial No.	H-A054-E-7
------------	------------

3-Way Ball Valve Type 23 Electric Actuated Type T

User's Manual

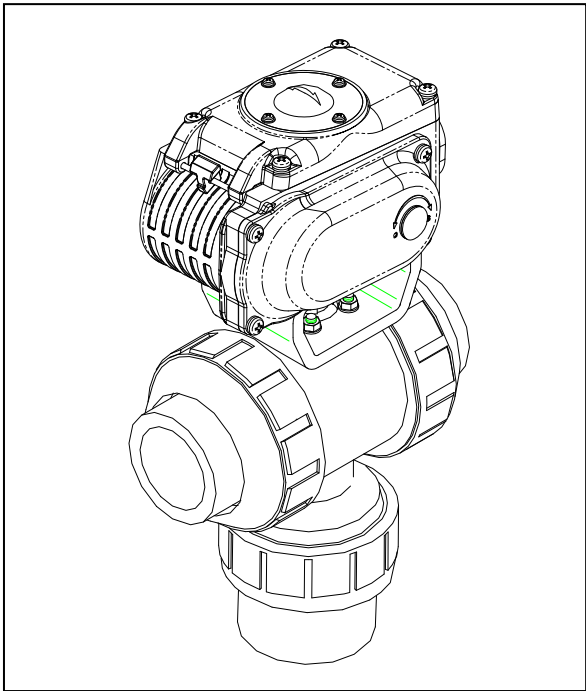



Contents



- (1) Be sure to read the following warranty clauses of our product 1
- (2) General operating instructions 2
- (3) General instructions for transportation, unpacking and storage 3
- (4) Name of parts 4
- (5) Working pressure vs. temperature 6
- (6) Specifications of actuator 7
 Wiring diagram 8
- (7) Installation procedure 10
- (8) Support setting procedure 15
- (9) Electric wiring procedure 16
- (10) Operating procedure 18
 Manual operating procedure 19
 Motor-driven operating procedure 19
- (11) Adjustment face pressure between ball and seat 20
- (12) Disassembling method for replacing parts 21
- (13) Adjustment limit switch 22
- (14) Inspection items 24
- (15) Troubleshooting 24
- (16) Handling of residual and waste materials 25

This user's guide contains information important to the proper installation, maintenance and safe use of an ASahi AV Product. Please store this manual in an easily accessible location.

<Warning & Caution Signs>

 Warning	This symbol reminds the user to take caution due to the potential for serious injury or death.
 Caution	This symbol reminds the user to take caution due to the potential for damage to the valve if used in such a manner.

<Prohibited & Mandatory Action Signs>

	Prohibited: When operating the valve, this symbol indicates an action that should not be taken.
	Mandatory action: When operating the valve, this symbol indicates mandatory actions that must be adhered to.

(1) Be sure to read the following warranty clauses of our product

- Always observe the specifications of and the precautions and instructions on using our product.
- We always strive to improve product quality and reliability, but cannot guarantee perfection. Therefore, should you intend to use this product with any equipment or machinery that may pose the risk of serious or even fatal injury, or property damage, ensure an appropriate safety design or take other measures with sufficient consideration given to possible problems. We shall assume no responsibility for any inconvenience stemming from any action on your part without our written consent in the form of specifications or other documented approval.
- The related technical documents, operation manuals, and other documentation prescribe precautions on selecting, constructing, installing, operating, maintaining, and servicing our products. For details, consult with our nearest distributor or agent.
- Our product warranty extends for one and a half years after the product is shipped from our factory or one year after the product is installed, whichever comes first. Any product abnormality that occurs during the warranty period or which is reported to us will be investigated immediately to identify its cause. Should our product be deemed defective, we shall assume the responsibility to repair or replace it free of charge.
- Any repair or replacement needed after the warranty period ends shall be charged to the customer.
- The warranty does not cover the following cases:
 - (1) Using our product under any condition not covered by our defined scope of warranty.
 - (2) Failure to observe our defined precautions or instructions regarding the construction, installation, handling, maintenance, or servicing of our product.
 - (3) Any inconvenience caused by any product other than ours.
 - (4) Remodeling or otherwise modifying our product by anyone other than us.
 - (5) Using any part of our product for anything other than the intended use of the product.
 - (6) Any abnormality that occurs due to a natural disaster, accident, or other incident not stemming from something inside our product.

(2) General operating instructions



Warning



- Do not disassemble or remodel the actuator.

- Do not operate the manual override while the actuator is energized.



- Keep hands and other extremities away from moving parts under all circumstances.

(Any such practice may get your hand, arm, or other part of your body caught.)

- Using a positive-pressure gas with our plastic piping may pose a dangerous condition due to the repellent force particular to compressible fluids even when the gas is under similar pressures used for liquids. Therefore, be sure to take the necessary safety precautions such as covering the piping with protective material. For inquiries, please contact us. For conducting a leak test on newly installed piping, be sure to check for leaks under water pressure. If absolutely necessary to use a gas in testing, please consult your nearest service station beforehand.

- Before using the product, check the operating power supply and the voltage specification on the nameplate. Using an improper voltage may cause equipment damage or malfunction.



Caution



- Do not step on or apply excessive weight on valve. (It can be damaged.)

- Do not use AV valves in a place where they may become submerged in water.

- Do not apply a great impact or vibration to the actuator. (Any such practice may result in breakdown.)

- Do not use the valve in conditions where the fluid may have crystallized.

(The valve will not operate properly.)

- While in operation, the actuator may rise in surface temperature. This is due to heat-up of the inner equipment and is not a sign of a breakdown. However, exceeding the permissible temperature may cause a breakdown.



- Keep the valve away from excessive heat or fire. (It can be damaged, or destroyed.)

- Avoid locations with corrosive gas or otherwise bad atmospheres. Install a cover or something similar that covers the entire area.

- Always operate the valve within the pressure vs. temperature range.

(The valve can be damaged or deformed by operating beyond the allowable range.)

- Allow sufficient space for maintenance and inspection.

- Select a valve material that is compatible with the media. For chemical resistance information, refer to "CHEMICAL RESISTANCE ON ASAHI AV VALVE".

(Some chemicals may damage incompatible valve materials.)

- Keep the valve out of direct sunlight, water and dust. Use cover to shield the valve.

(The valve will not operate properly.)

- Perform periodic maintenance. (Leakage may develop due to temperature changes or periods of prolonged storage, rest, or operation.)

- When installing a valve, provide an appropriate support. (Lack of such a support may cause the valve and piping to be overstrained, resulting in damage or other defect.)

- In the case of malodor, overheating, or smoking, turn off the power supply immediately. (Continued use despite an abnormality present may result in a fire. If you detect any abnormalities, be sure to consult the dealership where you bought the product or our service station nearest your premises and ask them to perform an inspection.)

- For manual operation, be sure to use the handle furnished with the product by the manufacturer.

- When using the product in explosive atmosphere, ensure that the actuator complies with the explosion-proof specifications required for that area.

- Keep the ambient temperature of the installed location within the range -10°C and 50°C.

(3) General instructions for transportation, unpacking and storage



- When suspending and supporting a valve, take care and do not stand under a suspended valve.

Warning



- This valve is not designed to handle impacts of any kind. Avoid throwing or dropping the valve.

Caution

- Avoid scratching the valve with any sharp object.

- Do not over-stack cardboard shipping boxes. Excessively stacked packages may collapse.

- Avoid contact with any coal tar creosote, insecticides, vermicides or paint.

(The force of swelling may damage the valve.)

- When transporting a valve, do not carry it by the handle.



- Store products in their corrugated cardboard boxes. Avoid exposing products to direct sunlight, and store them indoors (at room temperature). Also avoid storing products in areas with excessive temperatures. (Corrugated cardboard packages become weaker as they become wet with water or other liquid. Take care in storage and handling.)

- After unpacking the products, check that they are defect-free and meet the specifications.

(4) Name of parts

Nominal size 15-50mm (1/2"-2")

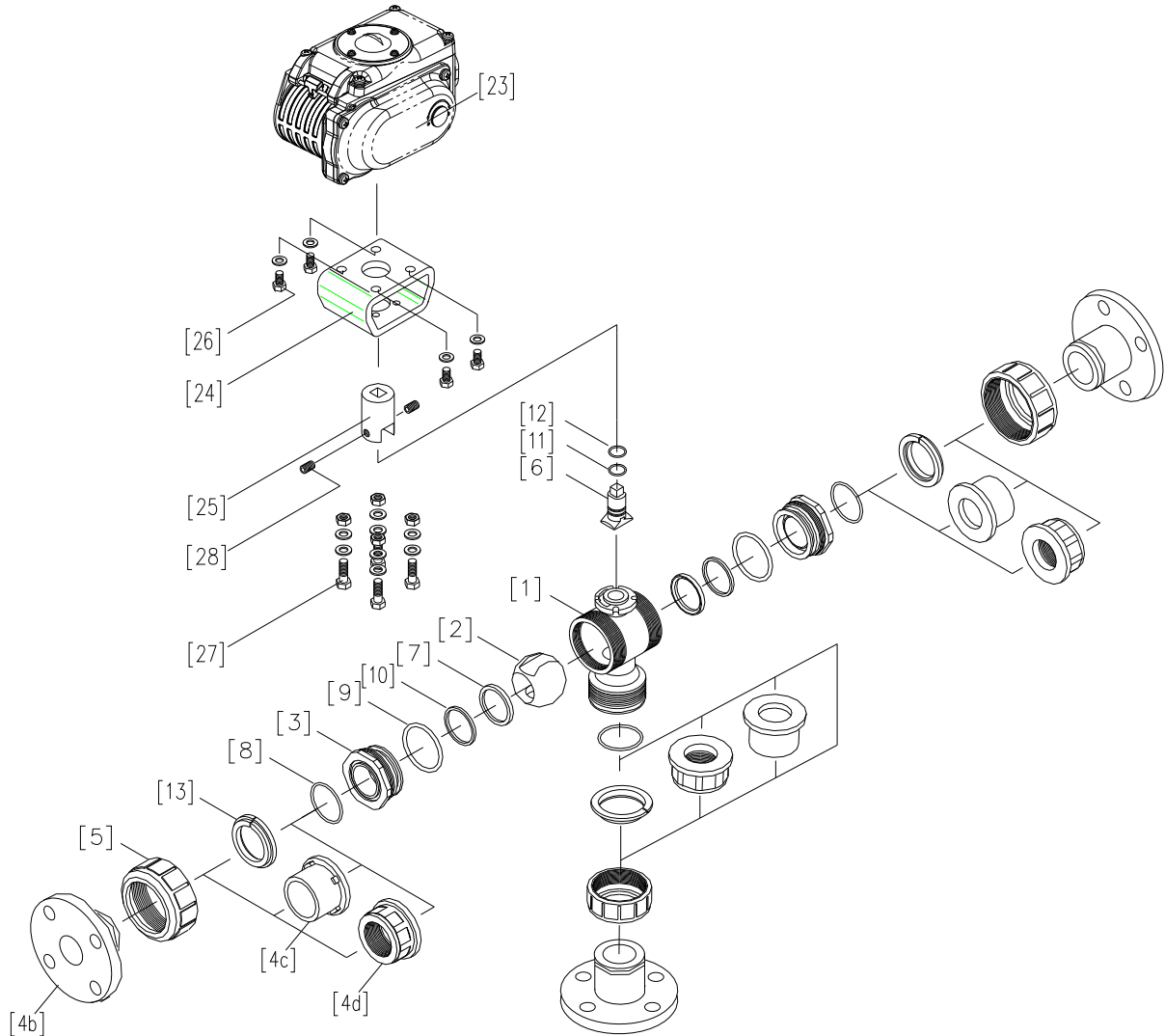

No.	DESCRIPTION	No.	DESCRIPTION	No.	DESCRIPTION
[1]	Body	[6]	Stem	[13]	Stop ring
[2]	Ball	[7]	Seat	[23]	Actuator
[3]	Carrier	[8]	O-ring (A)	[24]	Stand
[4b]	End connector (Flanged end type)	[9]	O-ring (B)	[25]	Joint
[4c]	End connector (Socket end type)	[10]	O-ring (C)	[26]	Bolt (A)
[4d]	End connector (Threaded end type)	[11]	O-ring (D)	[27]	Bolt•Nut (B)
[5]	Union nut	[12]	O-ring (E)	[28]	Screw (B)

Nominal size 65 -100mm (2 1/2"-4")

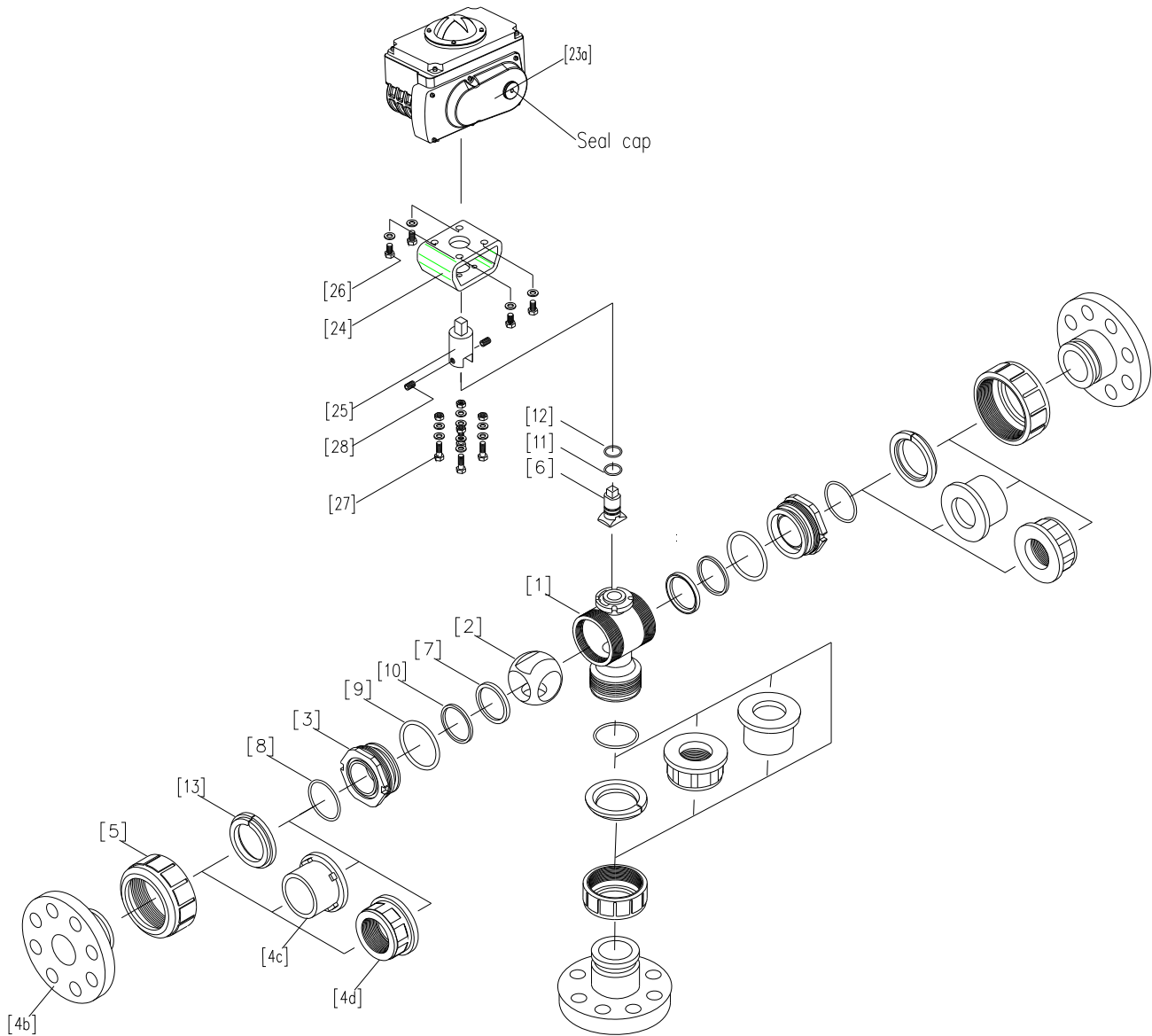

No.	DESCRIPTION	No.	DESCRIPTION	No.	DESCRIPTION
[1]	Body	[6]	Stem	[13]	Stop ring
[2]	Ball	[7]	Seat	[23a]	Actuator
[3]	Carrier	[8]	O-ring (A)	[24]	Stand
[4b]	End connector (Flanged end type)	[9]	O-ring (B)	[18]	Joint
[4c]	End connector (Socket end type)	[10]	Cushion	[19]	Bolt
[4d]	End connector (Threaded end type)	[11]	O-ring (D)	[20]	Bolt•Nut
[5]	Union Nut	[12]	O-ring (E)	[21]	Screw

(5) Working pressure vs. temperature

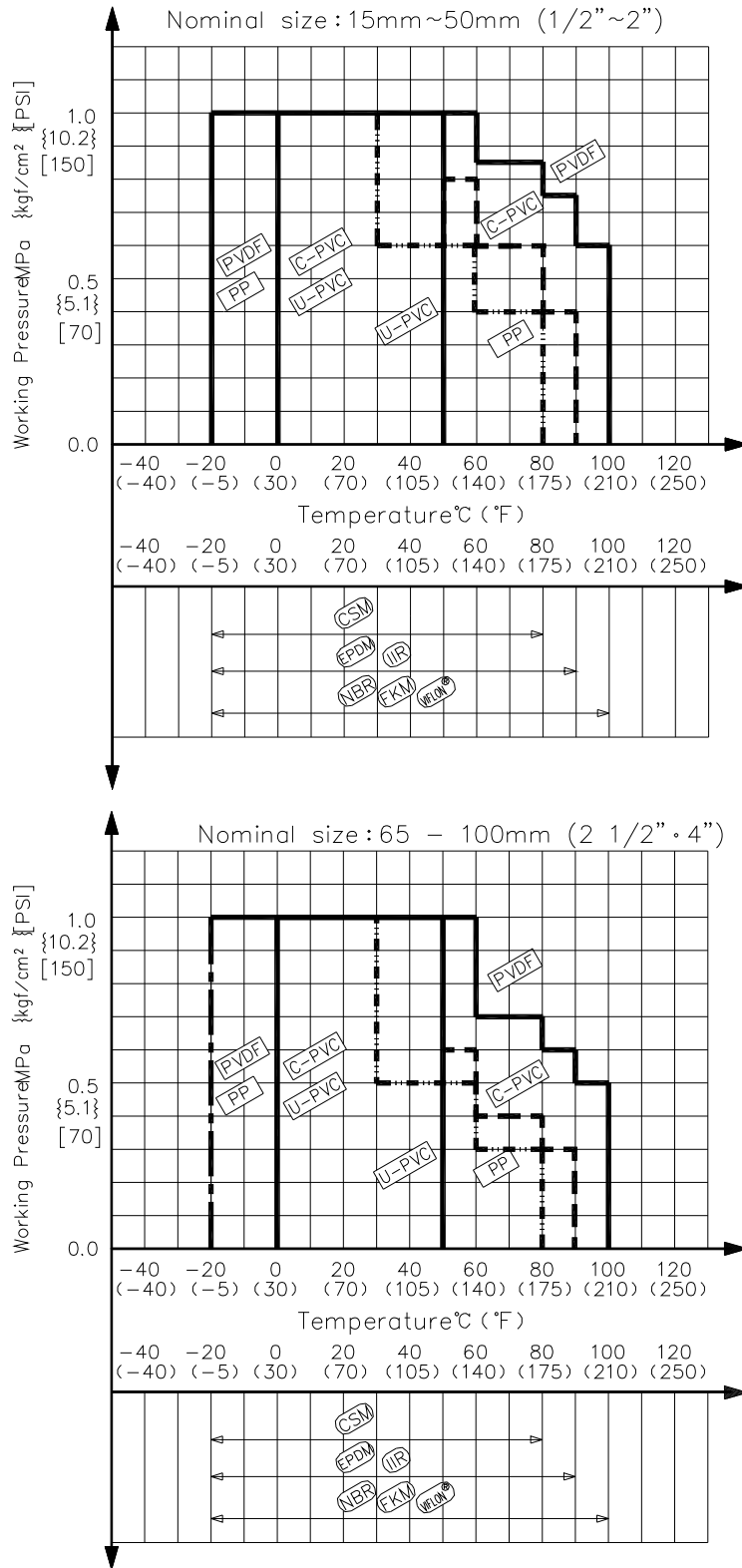

(6) Specifications of actuator

List of Specifications

Actuator Type		AOC-00	AOC-0
Nominal Size		15 - 50mm (1/2" - 2")	65 - 100mm (2 1/2" - 4")
Opening and Closing Time (Sec.)	50Hz	10	25
	60Hz	8	20
protection structure		JIS C0920 WaterJet proof type (IP65)	JIS C0920 WaterJet proof type (IP65)
Motor starting current (A) 50/60Hz	AC100V	0.80 / 0.80	1.20 / 1.20
	AC110V	1.00 / 1.00	1.40 / 1.40
	AC200V	0.50 / 0.50	0.50 / 0.50
	AC220V	0.70 / 0.70	0.70 / 0.70
Motor rated current (A) 50/60Hz	AC100V	0.40 / 0.40	0.50 / 0.50
	AC110V	0.50 / 0.50	0.60 / 0.60
	AC200V	0.25 / 0.25	0.25 / 0.25
	AC220V	0.30 / 0.30	0.30 / 0.30
Number of rotations of manual operating handle		7.5	6.7
Watt consumption (VA)	AC100V	40	50
	AC110V	44	55
	AC200V	50	60
	AC220V	55	66
Nominal diameter of cable connector		G1/2	
Motor rated output (W)		8	
By kind of motor insulation		E kind	
Motor rated time (min.)		30	
Capacity of limit switch		AC250V 5A	AC250V 5A
Space heater rated output(W)		2*	5
ambient temperature °C(°F)		-10 - 50 °C (14 - 122 °F)	

*Option

Wiring diagram Nominal Size: 15-50mm (1/2"-2") Actuator Type: AOC-00

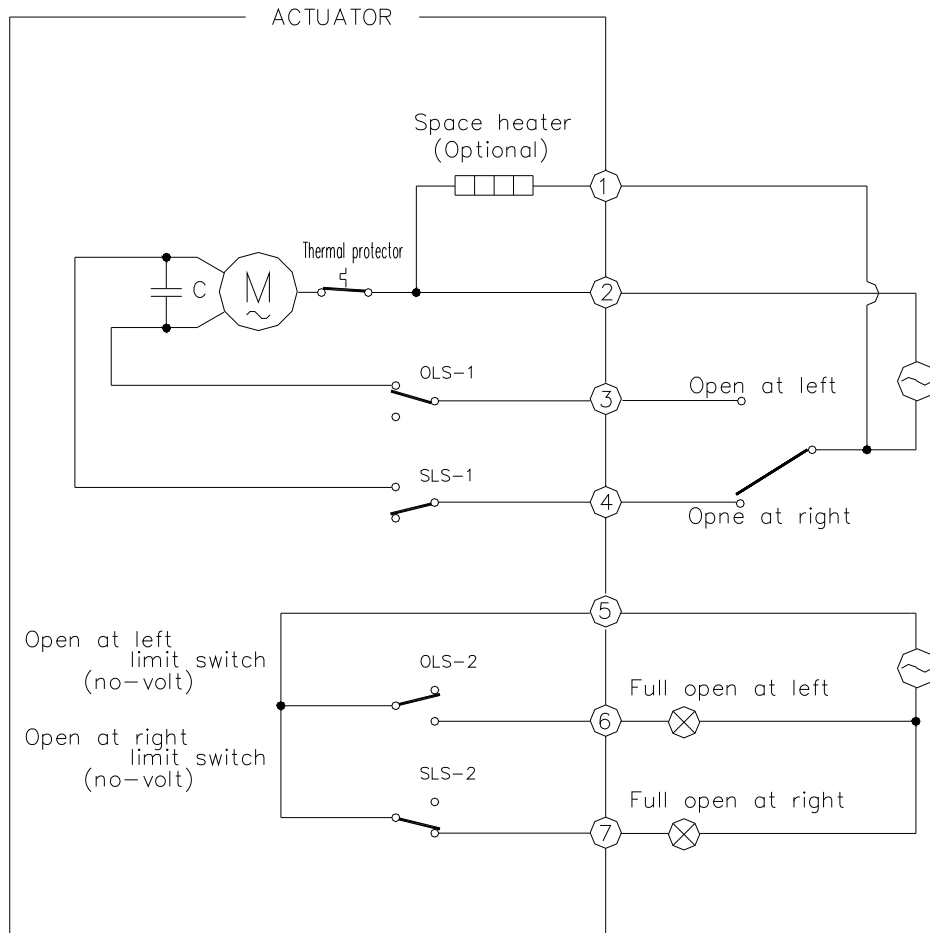

Note: The circuit diagram shows the position that the action to which the right side open has finished.

Switching chart

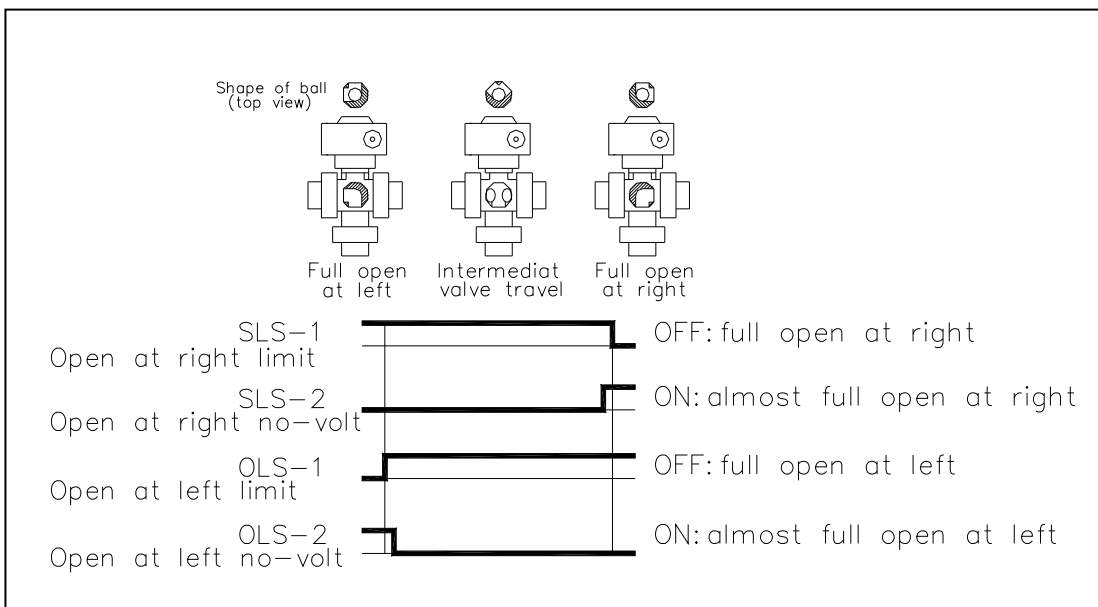

Wiring diaphragm Nominal Size: 65-100mm (2 1/2"-4") Actuator Type: AOC-0

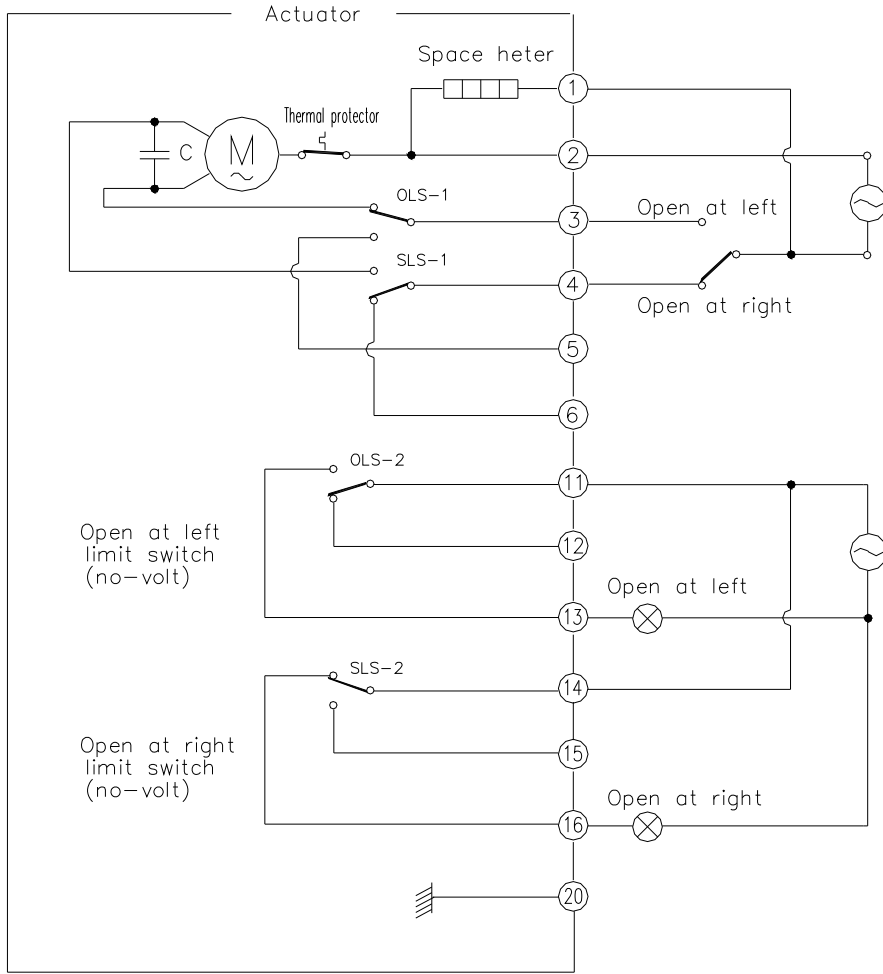

Note: The circuit diagram shows the position that the action to which the right side open has finished.

Switching chart

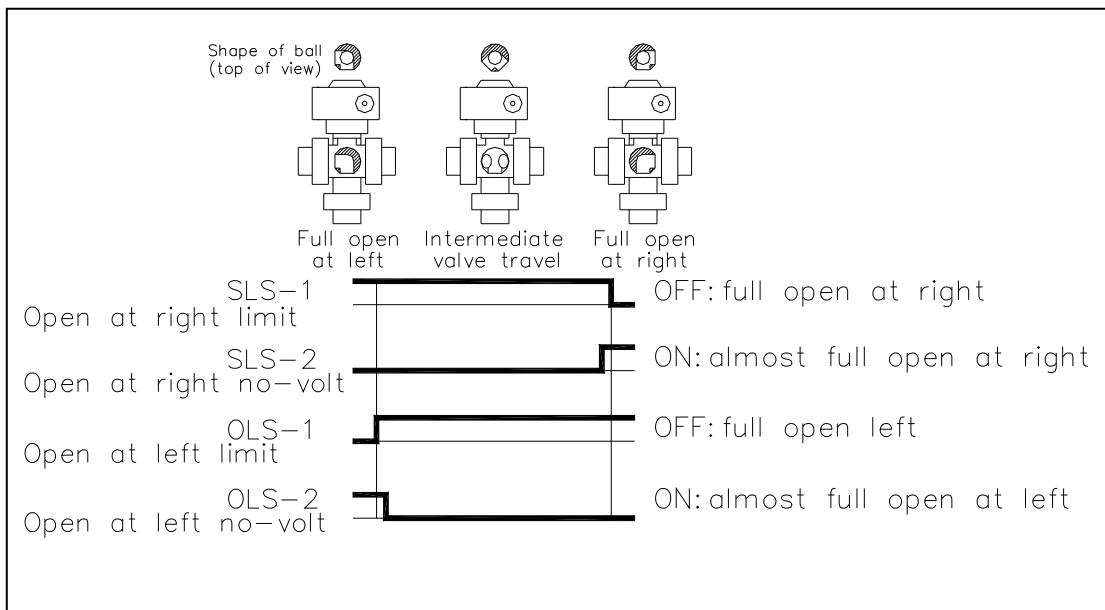

(7) Installation procedure

Warning

- When suspending and supporting a valve, take care and do not stand under a suspended valve.
- Be sure to conduct a safety check on all hand and power tools to be used before beginning work.
- Wear protective gloves and safety goggles as fluid remain in the valve even if the pipeline is empty. (You may be injured.)

Caution

- When installing a pipe support by means of a U-band or something similar, take care not to over-tighten. (Excessive force may damage the pipe.)
- Take care not to over-tighten the Union Nut. (The valve can be damaged.)
- Do not use the pipe wrench. (The valve can be damaged.)
- When installing pipes and valves, ensure that they are not subjected to tension, compression, bending, impact, or other excessive stress.
- When loosening the cap nut on the union side, fix the body cap (hold it with your hand) and do work. (If the body cap turns, the union will turn together, resulting in the union and ball separating from the body.) If the union is loosened, retighten the union.
- When installing, disassembling, or reassembling the piping, fix the End Connector.
- Before a water test, be sure that the Union Nut is tightly fastened.
- Fasten the Union Nut while avoiding the parallelism and axial misalignment of the flange surface.
- When connecting a ASAHI AV Valve to metal piping, take care not to let the pipe stress on the ASAHI AV Valve.

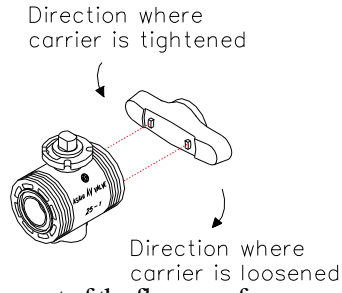

Flanged type (Material: PVC, C-PVC, PP, PVDF)

Caution

- Use flat faced flanges for connection to AV Valves.
- Ensure that the mating flanges are of the same standards.
- Be sure to use sealing gaskets (AV Gasket), bolts, nuts, and washers and tighten them to specified torques. (When a non-AV gasket is used, a different tightening torque specification should be followed.)



Necessary items

- Torque wrench
- AV gasket
- Spanner wrench
- Bolt, Nut, Washer (For many flanges specification)

Procedure

- 1) When the union nut [5] flange assembly set was removed or loosen from body[1], O-ring (A) [8] should be installed into carrier and body groove. (In either horizontal or vertical installation, if necessary apply a small amount of lubricant to O-ring to hold in place.) Align union nut and end connector with the body. Insure end connector mates with body and O-ring. Make certain union nut threads onto body smoothly. Tighten union nuts on each side valve until hand tight. Then using a strap wrench tighten union nuts uniformly on each side approx 90° -180° turns, 1/4 to 1/2 turns.

- 2) Set the AV gasket between the flanges.
- 3) Insert washers and bolts from the pipe side, insert washers and nuts from the valve side, then temporarily tighten them by hand.

  - The parallelism and axial misalignment of the flange surface should be under the values shown (A failure to observe them can cause destruction due to stress application to the pipe)

Unit : mm (inch)

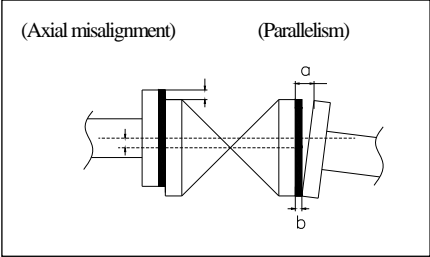
Nom. Size	Axial Misalignment	Parallelism (a-b)	
15-32mm (1/2"-1 1/4")	1.0mm (0.04")	0.5mm (0.02")	
40-80mm (1 1/2"-3")	1.0mm (0.04")	0.8mm (0.03")	
100mm (4")	1.0mm (0.04")	1.0mm (0.04")	

- 4) Tighten the bolts and nuts gradually with a torque wrench to the specified torque level in a diagonal manner. (Refer to fig.1.)



  - Tighten the bolts and nuts gradually with a torque wrench to the specified torque level in a diagonal manner.

Fig. 1



Recommended torque value	Unit: N·m {kgf·cm} [lb·inch]			
Nom. Size	15-20mm (1/2"-3/4")	25-40mm (1"-1 1/2")	50, 65mm (2", 2 1/2")	80, 100mm (3", 4")
PTFE·PVDF coated	17.5 {179} [155]	20.0 {204} [177]	22.5 {230} [230]	30.0 {306} [266]
Rubber	8.0 {82} [71]	20.0 {204} [177]	22.5 {230} [230]	30.0 {306} [266]

Threaded type (Material : PVC, C-PVC, PP, PVDF)

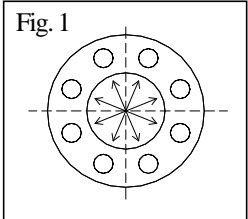
Caution



- Avoid excessive tightening. (The valve can be damaged.)

- Make sure that the threaded connections are plastic x plastic. (Metallic thread can cause damage.)

- Wrap the threaded joints on our plastic piping with sealing tape. Using a liquid sealing agent or liquid gasket may cause stress cracks (Environmental Stress Cracking). Our product warranty shall not apply in case of said use, even when said use is unavoidable.

Necessary items

- Sealing tape
- Strap wrench
- Spanner wrench

Procedure

- 1) Wind a sealing tape around the external thread of joint, leaving the end (about 3mm) free.
- 2) Loosen the union nut [5] with a strap wrench.
- 3) Remove the union nut [5] and the end connector [4d].
- 4) Lead the union nut [5] through the pipe.
- 5) Tighten the external thread of the joint and the end connector [4d] hardly with hand.
- 6) Using a spanner wrench, screw in the end connector [4d] by turning 180° -360° carefully without damaging it.
*Avoid excessive tightening. (The valve can be damaged.)
- 7) Make sure that the O-ring (A) [8] is mounted.
- 8) Set the end connector [4d] and union nut [5] directly on the body without allowing the O-ring (A) [8] to come off.
- 9) Tighten union nuts [5] on each valve until hand tight.
- 10) Using a strap wrench tighten union nuts uniformly on each on each side approx 90° -180° turns, 1/4 to 1/2 turns.
*Take care not to over-tighten the Union Nut. (The valve can be damaged.)

Socket type (Material : PVC, C-PVC)

 **Warning** - When using an adhesive, ventilate the space sufficiently, prohibit the use of a fire in the vicinity, and do not inhale adhesive vapors directly.

 - If an adhesive gets into contact with your skin, wash it off immediately. If you feel sick or find any anomaly, receive a physician's diagnosis and take appropriate measures promptly.

 **Caution** - Take care in doing work at low temperatures. Solvent vapors are hard to evaporate and are likely to remain. (Solvent cracks may occur, damaging the equipment.) After assembling the piping system, open both ends of the piping and use a fan (of the Low-Voltage Type) or something similar to ventilate the space, thus removing the solvent vapors.

 - Use the appropriate Asahi AV cement.
 - Conduct a water test at least 24 hours after joining the pipes with an adhesive/cement.

Necessary items

- Adhesive for hard vinyl chloride pipes
- Strap wrench

Procedure

- 1) Loosen the union nut [5] with a strap wrench.
 - 2) Remove the union nut [5] and end connector [4c].
 - 3) Lead the union nut through the pipe.
 - 4) Clean the hub part of the end connector [4c] by wiping the waste cloth.
 - 5) Apply adhesive evenly to the hub part of the end connector [4c] and the pipe spigot.
- * Do not apply more adhesive than necessary. (The valve can be damaged due to solvent cracking.)

Adhesive quantity (guideline)

Nom. Size	15mm (1/2")	20mm (3/4")	25mm (1")	32mm (1 1/4")	40mm (1 1/2")	50mm (2")	65mm (2 1/2")	80mm (3")	100mm (4")
Quantity(g)	1.0	1.3	2.0	2.4	3.5	4.8	6.9	9.0	13.0

- 6) After applying adhesive, insert the pipe quickly to the end connector [4c] and leave it alone for at least 60 seconds.
 * Do not under any circumstances try to insert a pipe into another fitting or valve by striking it, which may break the piping.
- 7) Wipe away overflowing adhesive.
- 8) Make sure that O-ring(A) [8] is mounted
- 9) Set the end connector [4c] and union nut [5] directly on the body without allowing the O-ring (A) [8] to come off.
- 10) Tighten union nut [5] hardly with hand.
- 11) Using a strap wrench tighten union nuts uniformly on each side approx 90° -180° turns, 1/4 to 1/2 turns.
 * Take care not to over-tighten the Union Nut. (The valve can be damaged.)

Socket type (Material : PP, PVDF)

Necessary items

- Strap wrench
- Sleeve welder or automatic welding machine
- User's manual for sleeve welder or automatic welding machine

Procedure

- 1) Loosen the union nut with a strap wrench.
- 2) Remove the union nut [5] and the end connector.
- 3) Lead the union nut [5] through the pipe.
- 4) For the next step, refer to the user's manual for the sleeve welder or the automatic welding machine.
- 5) After welding, make sure that the O-ring (A) [8] is mounted.
- 6) Set the end connector [4c] and the union nut [5] directly without allowing the O-ring (A) [8] to come off.
- 7) Tighten union nut [5] hardly with hand.
- 8) Using a strap wrench tighten union nuts uniformly on each side approx 90° -180° turns, 1/4 to 1/2 turns.
* Take care not to over-tighten the Union Nut. (The valve can be damaged.)

Spigot type (Material : PVDF)

Necessary items

- Strap wrench
- Automatic welding machine
- User's manual for automatic welding machine

Procedure

- 1) Loosen the union nut with a strap wrench.
- 2) Remove the union nut [5] and the end connector.
- 3) Lead the union nut [5] through the pipe.
- 4) For the next step, refer to the user's manual for the sleeve welder or the automatic welding machine.
- 5) After welding, make sure that the O-ring (A) [8] is mounted.
- 6) Set the end connector [4e] and the union nut [5] directly without allowing the O-ring (A) [8] to come off.
- 7) Tighten union nut [5] hardly with hand.
- 8) Using a strap wrench tighten union nuts uniformly on each side approx 90° -180° turns, 1/4 to 1/2 turns.
* Take care not to over-tighten the Union Nut. (The valve can be damaged.)

(8) Support setting procedure



Caution



- Do not subject the valve to pump vibrations. (The valve may be damaged.)

- Valves must be supported. (The valve may be damaged by the weight of the actuator if it is unsupported.)

Necessary items

● Spanner wrench

● U-type clamp (with bolt)

● Rubber sheet

Level installation

Spread the rubber sheet on the pipe and secure pipe with U-type clamp.

In case that the actuator is under the pipe, spread the rubber sheet under the pipe, then set the stand.

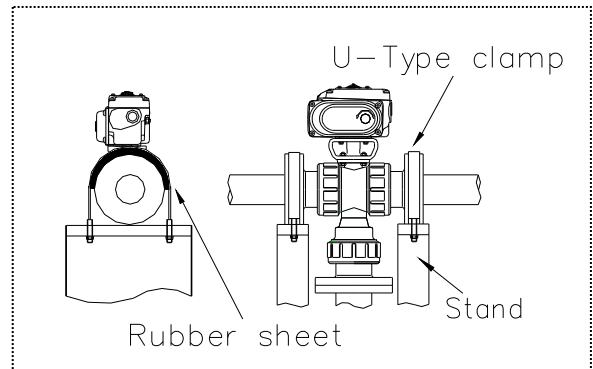

Perpendicular installation

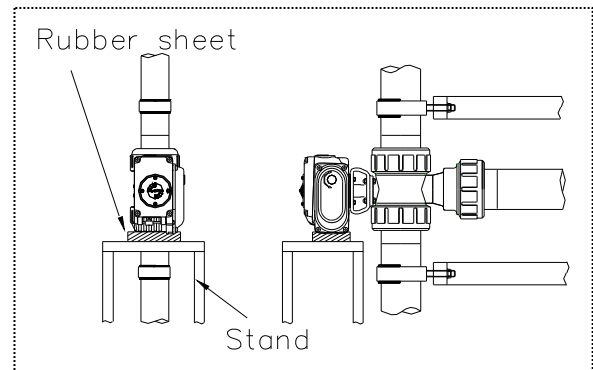

Spread the rubber sheet on the pipe and fix pipe with U-type band.



(9) Electric wiring procedure

- 

Warning

 - Do not touch any parts on actuator circuit board or terminal block or connect or disconnect wires while the actuator is energized. (Any such practice may result in an electric shock or equipment damage.)
 - Do not operate the manual override while the actuator is energized.
- 
 - Keep hands and other extremities away from moving parts under all circumstances. (Any such practice may get your hand, arm, or other part of your body caught.)
 - Be sure to establish a ground. (A defective ground may result in an electrical shock, fire, or other incident.)
 - At the time of adjustment or inspection, ensure that your hands are free of water and oil. (Any such substance on your hands may result in an electric shock or equipment damage.)
- 

Caution

 - Do not exceed the rated capacity of limit switch contacts. If you wish to apply very small loads (1-100 mA, 5-30 V), consult our service station nearest to you.
 - Do not connect two or more motor-driven valves in series. Also, install a switch (or a relay contact) for each motor-driven valve.
 - Do not use the product near high-voltage wire, inverter, or any other equipment that produces electrical noise or magnetism. (The presence of such nearby may cause malfunction or breakdown.)
- 
 - Check the integrity of wiring insulation before connecting to the actuator. (Failure to observe this precaution may result in wire damage.)
 - Ensure all covers are tightly fastened prior to operation. (Insufficient fastening may allow rainwater, dust, or dirt to come in, resulting in breakdown.)
 - When connecting wires, be sure to observe the connection diagram and make the connections correctly. Moreover, after wiring, ensure that the connections are securely made before turning on the power. (Failure to take this precaution may cause malfunction or breakdown.)
 - Each cover part is sealed with an O-ring. When laying wiring or in similar cases, where the cover is removed and replaced, ensure that the O-ring is installed in the specified location and securely sealed. (Insufficient sealing may cause the actuator to be penetrated by rainwater or other foreign matter, resulting in electric shock or breakdown.)
 - If you wish to use the product outdoors or in any other location exposed to rainwater or other forms of moisture, protect the wiring conduit of the actuator against ingress of rainwater and all other wetness. (Failure to take such a precaution may cause the actuator to be penetrated by rainwater or something similar, resulting in electric shock or breakdown.)
 - In the case of malodor, overheating, or smoking, turn off the power supply immediately. (Continued use despite an abnormality present may result in a fire. If you detect any abnormalities, be sure to consult the dealership where you bought the product or our service station nearest your premises and ask them to perform an inspection.)

- Necessary items
- Spanner wrench
 - Terminal crimping tool
 - Connector
 - Wire stripper
 - Allen wrench
 - Crimp-style terminal
 - Screwdriver (+)

*Check supply voltage indicated on the actuator and make sure it is the same as the voltage applied, before completing the wiring. (Wiring at different voltages will cause problems in the AV valve.)

Procedure

- 1) Loosen the 4 screws fixing the switch cover, using a Phillips screwdriver (AOC-00) or Allen wrench (AOC-0), and open the cover. For wiring the model AOC-00 being used in vertical piping, open the cover, slide the stopper, and fix the cap.
- 2) Loosen and remove the protection screws in the lead port, using an adjustable wrench.
- 3) Mount a connector on the lead port.
- 4) Lead a cable through the connector.
- 5) Peel off the outer shell of the cable, using a wire stripper.
- 6) Attach a crimping terminal, using a terminal crimping tool.
- 7) Connect wires on the terminal block, using a Phillips screwdriver, as described in the pages 8 and 9.
 - * Tighten the screws firmly.
 - (Electricity leak or electric shock may be caused.)
- 8) Tighten the connector.
 - * Tighten the connector firmly. (Ingression of storm water may be resulted, causing electricity leak or electric shock.)
- 9) Connect a grounding wire. (refer to the page 8, 9)
 - On the screw on the rear of the body for the model AOC-00
 - On the terminal for the model AOC-0
- 10) Tighten the 4 screws fixing the actuator cover, using a Phillips screwdriver (AOC-00) or Allen wrench (AOC-0), to install the cover.

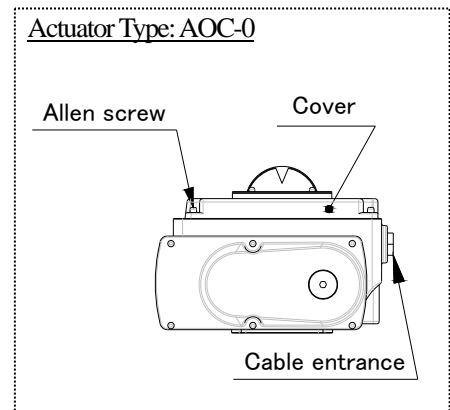
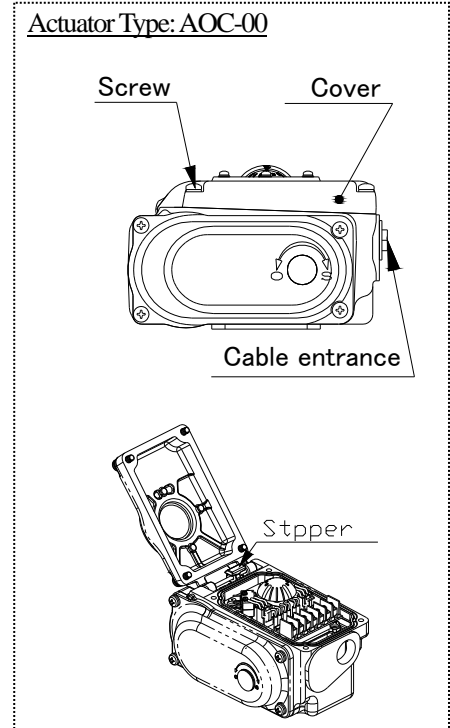

(10) Operating procedure



Warning

- Do not touch any parts on actuator circuit board or terminal block or connect or disconnect wires while the actuator is energized. (Any such practice may result in an electric shock or equipment damage.)
- Do not operate the manual override while the actuator is energized.



- Keep hands and other extremities away from moving parts under all circumstances. (Any such practice may get your hand, arm, or other part of your body caught.)
- Be sure to establish a ground. (A defective ground may result in an electrical shock, fire, or other incident.)
- At the time of adjustment or inspection, ensure that your hands are free of water and oil. (Any such substance on your hands may result in an electric shock or equipment damage.)



Caution

- Do not connect two or more motor-driven valves in series. Also, install a switch (or a relay contact) for each motor-driven valve.
 - Do not use the product near high-voltage wire, inverter, or any other equipment that produces electrical noise or magnetism. (The presence of such nearby may cause malfunction or breakdown.)
- 
- Check the integrity of wiring insulation before connecting to the actuator. (Failure to observe this precaution may result in wire damage.)
 - Ensure all covers are tightly fastened prior to operation. (Insufficient fastening may allow rainwater, dust, or dirt to come in, resulting in breakdown.)
 - When connecting wires, be sure to observe the connection diagram and make the connections correctly. Moreover, after wiring, ensure that the connections are securely made before turning on the power. (Failure to take this precaution may cause malfunction or breakdown.)
 - Each cover part is sealed with an O-ring. When laying wiring or in similar cases, where the cover is removed and replaced, ensure that the O-ring is installed in the specified location and securely sealed. (Insufficient sealing may cause the actuator to be penetrated by rainwater or other foreign matter, resulting in electric shock or breakdown.)
 - If you wish to use the product outdoors or in any other location exposed to rainwater or other forms of moisture, protect the wiring conduit of the actuator against ingress of rainwater and all other wetness. (Failure to take such a precaution may cause the actuator to be penetrated by rainwater or something similar, resulting in electric shock or breakdown.)
 - In the case of malodor, overheating, or smoking, turn off the power supply immediately. (Continued use despite an abnormality present may result in a fire. If you detect any abnormalities, be sure to consult the dealership where you bought the product or our service station nearest your premises and ask them to perform an inspection.)

Manual Operating Procedure



- Turn off the power source.
(If the power source is turned on during the manual operation, you may be injured.)

Necessary items

- Manual operating Lever (*Option: AOC-00) or allen wrench (5mm)

Procedure

- 1) Put the allen wrench in the hexagon socket of the manual operation shaft of the actuator.
- 2) Fully open the valve once or twice while watching the valve travel indicator.

Right turn (clock wise) → Left open direction

Left turn (counter clock wise) → Right open direction

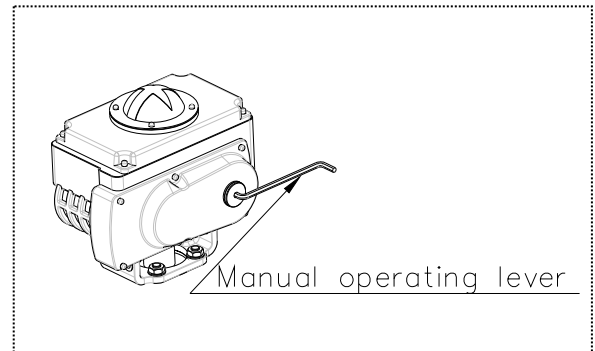

* Do not turn the handle forcibly at the right and left full operating positions. (If not, a trouble will develop.)

- 3) Remove the allen wrench from the manual operation shaft in state where the valve is opened fully.

Motor-Driven Operating Procedure



- Do not leave the cover removed from the actuator.
(Coming into contact with a terminal in this state can give you an electric shock.)



- Check to ensure that the spanner is not applied to the end of the manual operation shaft.
(If not, the hexagon wrench will be flown by the rotation of the manual operation shaft, and this may injure you)

Procedure

- 1) Turn on the power source.
- 2) Set the external switch to “Left open” or “Right open”, and check to ensure that the valve indicating direction and the operating direction agree with each other.
- 3) Turn off the power source in the state of the Left open or Right open.

(11) Adjustment face pressure between ball and seat

Caution

- ⚠ - Take care not to over-tighten the Union Nut. (The valve can be damaged.)
- 🚫 - Do not use the pipe wrench. (The valve can be damaged.)
- ⚠ - Wear protective gloves and safety goggles as fluid remain in the valve even if the pipeline is empty. (You may be injured.)



- Necessary items**
- Strap wrench
 - allen wrench (5mm)
 - Handle [14](*Option)
 - Protective gloves
 - Safety goggles

Procedure

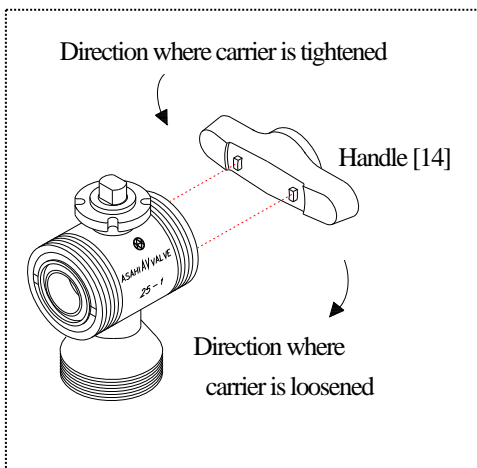
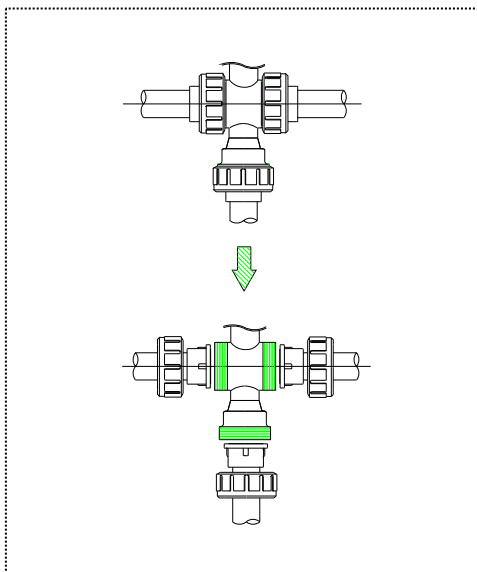





- 1) Completely discharge fluid from pipes.
- 2) Fully close the valve at right or left by the motor-driven operation.
- 3) Turn off the power source.
- 4) Loosen three union nuts [5] with a strap wrench.
- 5) Remove the body part from piping system.
- 6) Engage the upper convex part of the handle [14] with the concave part of the union.
 - * Only the union [3] on the right side when viewed from the trademark (AV mark) can be adjusted.
- 7) Make an adjustment by turning the union clockwise (to tighten it) or counter clockwise (to loose it).
- 8) Make sure that the handle can be operated smoothly.
- 9) Assemble the valve by following the above procedure in the reverse order, starting at 5).



(12) Disassembling method for replacing parts

- Warning**  - Do not disassemble or remodel the actuator.
- Do not touch any parts on actuator circuit board or terminal block or connect or disconnect wires while the actuator is energized. (Any such practice may result in an electric shock or equipment damage.)
 - Do not change or replace valve parts under line pressure.
- !** - Be sure to conduct a safety check on all hand and power tools to be used before beginning work.
- Wear protective gloves and safety goggles as fluid remain in the valve even if the pipeline is empty. (You may be injured.)
- Caution**  **!** - Ensure all covers are tightly fastened prior to operation. (Insufficient fastening may allow rainwater, dust, or dirt to come in, resulting in breakdown.)
- The actuator has been adjusted at the factory. If reconfiguration or adjustment is needed, do so correctly according to the relevant operation manual. (Failure to observe this instruction may cause malfunction or breakdown.)
 - Each cover part is sealed with an O-ring. When laying wiring or in similar cases, where the cover is removed and replaced, ensure that the O-ring is installed in the specified location and securely sealed. (Insufficient sealing may cause the actuator to be penetrated by rainwater or other foreign matter, resulting in electric shock or breakdown.)

Necessary items

-  Strap wrench
-  Allen wrench (5mm)
-  Handle [14>(*Option)
-  Protective gloves
-  Safety goggles
-  Spanner wrench

<Disassembly>

Procedure

- 1) Completely discharge fluid from pipes.
- 2) Fully open the valve at left by motor-driven operations.
- 3) Turn off the power source.
- 4) Loosen the union nut [5] with a strap wrench.
- 5) Remove the body from the piping system.
- 6) Loosen the bolt [26], and remove actuator [23] from stand.
- 7) Loosen the set screw [28] with an allen wrench, and remove joint [25] from stem [6].
- 8) Loosen nut and bolt [27] with a spanner wrench, and remove stand [24] from the top flange.
- 9) Engage the upper convex part of the handle [14] with the concave part of the union.
 - * Only the union [3] on the right side when viewed from the trademark (AV mark) can be adjusted.
- 10) In the engaged state, turn the handle [14] counter clockwise to loosen it and remove the union [3].
- 11) Remove the seat [7] carefully by hand without damaging it.
- 12) Push out the ball [2] by hand.
- 13) Push out the stem [6] from the top flange side to the body side.

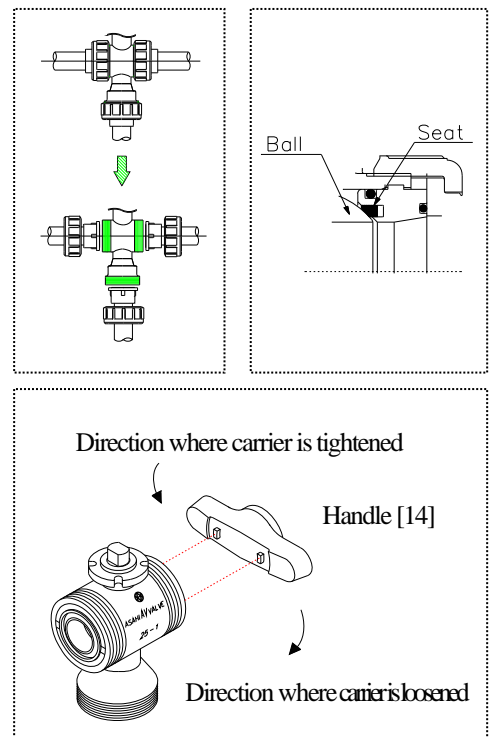

<Assembly>

Procedure

Carry out the assembly work in the reverse procedure from item 10)

* With regard to item 11), before installing seat [7] on the valve, check the seat for its face and back. depression side = engagement with ball (Refer to page 4, 5)

(13) Adjustment limit switch

Warning  - Shut down the power on the equipment before connecting wires. There are risks of electrical shock depending on the level of operating voltage.

Caution  - Be sure that the cover is put on during operation.

 - If you plan to operate limit switches at 1mA-100mA or 5-30V, consult your nearest Asahi dealer.
 - The model AOC-00 is not allowed with a transitional adjustment of the open ratio of the valve by adjusting the limit switch.

In case of adjusting the open/close limit switch, make sure to loosen the nuts fixing the stopper bolts and turn the stopper bolts 4 to 5 times to the loosening direction. (No adjustment of the open/close limit switch is normally required, as it is adjusted at factory shipment.)

Nominal size 15-50mm (1/2"-2") Actuator Type: AOC-00

Necessary items

- Screw driver (+)
- Manual operation handle (option for 15 to 50 mm) or Allen wrench (5 mm)

Procedure

- 1) Turn off the power and completely drain the fluid within piping.
- 2) Manually turn the valve toward the full-open direction, using an Allen wrench or the manual operation handle (option). (Refer to the page 18.)
- 3) Loosen and open the actuator cover, using a screw driver (+), and pull out the open ratio indication plate upward.
- 4) Loosen the two locking screws fixing the cam on the stem, using a screw driver (+).
- 5) Turn the cam clockwise until contacts two limit switches. (Please be sure to confirm the cam contacts two limit switches by clicking sound.) The cams are divided into upper and lower. The upper cam is for the contacting limit switch of clockwise direction and the lower cam is for counterclockwise direction.
- 6) While holding the cam, tighten it with the two locking screws, using a screw driver (+).
- 7) Referring to the page 18, confirm the travel position is in the demanded position. If not, back to the steps 4), 5) and 6) to repeat the adjustments.
- 8) Remove the Allen wrench from the manual operation shaft.
- 9) Mount the open ratio indication plate. Place and tighten the actuator cover, using a Phillips screwdriver.

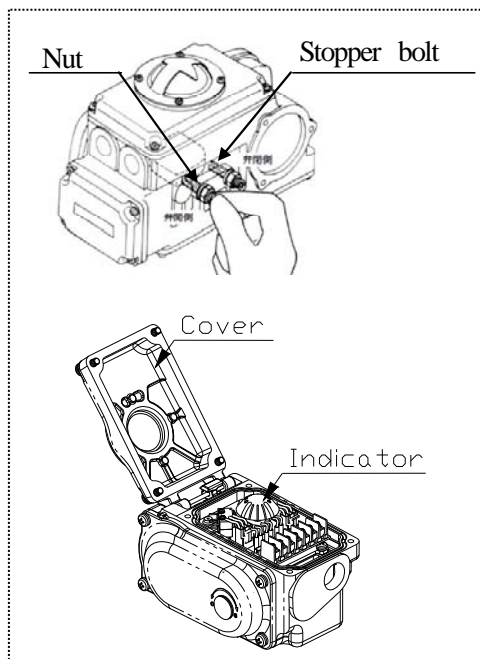

- Referring to the page 18, alternately bring the limit switch to the full counterclockwise and full clockwise positions, applying the motor power. Confirm that the indication of the open ratio is in the position of “O” for full counterclockwise or “S” for full clockwise.

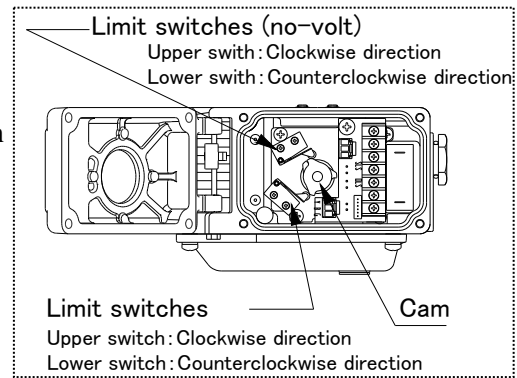

Nominal size 65-100mm (2 1/2” – 4”) Actuator Type: AOC-0

- Necessary items
- Allen wrench (3mm)
 - Screw driver (+)
 - Manual operation handle or Allen wrench (5 mm)

* In case of adjusting the open/close limit switch, make sure to loosen the nuts fixing the stopper bolts and turn the stopper bolts 4 to 5 times to the loosening direction. (No adjustment of the open/close limit switch is normally required, as it is adjusted at factory shipment.)

Procedure

- Turn off the power supplied to the actuator and completely drain the fluid within piping.
- Loosen and remove the Allen bolts in the actuator cover, using an Allen wrench. Pull out the indicator upward.
- Manually turn the cam toward a position corresponding to the desired open ratio (open at right or open at left), using the manual operation handle. (Refer to the page 18.)
- Loosen the setscrews for the limit switch cam to be adjusted, using an Allen wrench.
- Move the cam toward the direction of the desired adjustment. Confirm that the limit switch operates.
- While holding the cam, tighten the setscrews, using an Allen wrench.

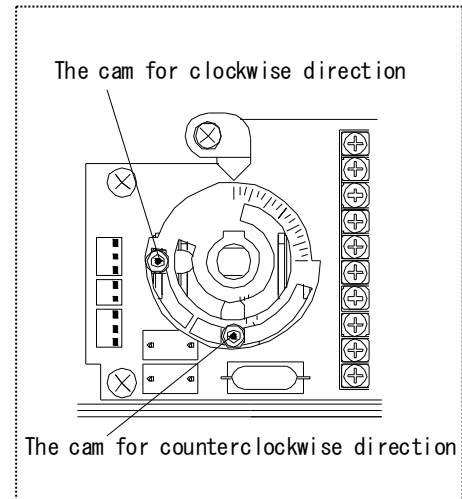

The positions where the limit switch makes contacts are stop positions for full counterclockwise and full clockwise. Positions for signal outputs are 2 to 3 % before the contact positions.

- Referring to the page 18, turn the limit switch cam to the position where the cam makes contacts with the limit switch of clockwise direction. Turn the clockwise direction stopper bolt by hand to its end, and, from there, return by 1/4 to 1/2 revolution toward the loosening direction. Tighten the nuts.

Similarly to the above, adjust the counterclockwise direction; turn the limit switch to the position where the cam makes contacts with the limit switch of counterclockwise direction. Adjust the counterclockwise direction stopper bolt, similarly to the clockwise.



Confirm that the desired open ratio is attained by manually operating the cams.

Repeat the steps 3) through 6) above, in case of insufficient adjustment.

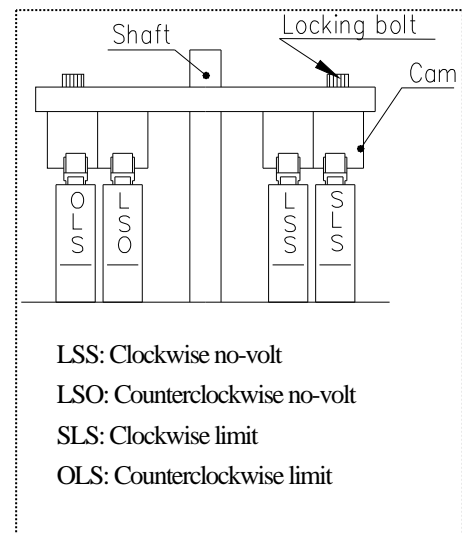
- Place and tighten the actuator cover, using a screwdriver (+).
- Referring to the page 18, alternately bring the limit switch to the open at right or open at left positions, applying the motor power. Confirm that the indication of the open ratio is in the position of “O” for full counterclockwise or “S” for full clockwise.



(14) Inspection items

  - Perform periodic maintenance. (Leakage may develop due to temperature changes or over periods of prolonged storage, rest or operation.)

○ Periodically inspect and maintain the AV valve in accordance with the decided schedule.



Portion to be inspected	Inspection item
Actuator	<ul style="list-style-type: none"> - Existence of rust, peeling of paint, and dirt of inspection hole of valve travel indicator. - Tightening condition of respective threaded portions. (Loose or not) - Existence of rust and corrosion around the limit switch, and existence of internal disconnection. - Existence of rust and corrosion of terminal board, and existence of disconnection. - Existence of abnormality in opening and closing operating sounds. - Smooth operation of manual handle. *It is unnecessary to supply oil to this actuator, because molybdenum disulfide (MoS₂) is used as a lubricant in the actuator.
Valve	<ul style="list-style-type: none"> - Existence of scratches, cracks, deformation, and discoloring. - Existence of leakage from the valve to the outside. - Existence of leakage when the valve is opened fully at right or left.

(15) Troubleshooting

Problem	Cause	Treatment
The handle is not (can't be)turned when the valve is operated manually.	The valve has already been opened fully.	Turn the handle in the reverse direction.
	The valve is kept as it is electrified in the direction reverse to the handle operating direction.	Turn of the power source.
	Foreign matter is in the valve.	Disassemble the valve to remove foreign matter. (Refer to page 21)
	The torque of the valve is increased by the piping stress.	Remove the piping stress.
	The torque is increased by the influence (temperature, components, pressure) of fluid on the valve.	Check service condition. (Refer to page 6)
The valve does not operate by motor-driven operations	The power source of the control panel is turned off.	Turn on the power source.
	The actuator is disconnected.	Check the connection again. (Refer to page 8, 9)
	Open and close are electrified simultaneously	
	The actuator is connected wrongly.	

Problem	Cause	Treatment
The valve does not operate by motor-driven operations	The supply voltage is wrong.	Check voltage with a tester and set specified voltage.
	The voltage is low.	
	Foreign matter is in the valve.	Disassemble the valve to remove foreign matter. (Refer to page 21)
	The torque of the valve is increased by the piping stress.	Remove the piping stress.
	The torque is increased by the influence (temperature, components, pressure) of fluid on the valve.	Check service condition. (Refer to page 6)
Fluid leaks from the valve even when the valve is closed fully.	The carrier is loosened.	Adjust the face pressure between the ball and the seat. (Refer to page 21)
	The seat is worn.	Replace the seat with a new one. (Refer to page 21)
	The seat and ball are scratched.	Replace the scratched seat and ball with new ones. (Refer to page 21)
	Foreign matter is in the valve.	Discharge the foreign matter from the valve by opening and closing the valve several times.
Fluid leaks from the valve.	The union nut is loosened.	Tighten up the union nut.
	The O-ring is scratched or worn.	Replace the O-ring with a new one. (Refer to page 21)
	The O-ring is projected from the groove.	
	The sliding face or the fixed face of the O-ring is scratched or worn.	Replace the sliding face or the fixed face with a new one. (Refer to page 21)
The actuator operates, but the valve is not opened or close.	The stem or the joint is broken.	Replace the stem or the joint with a new one.
	The engagement between the stem and the ball is broken.	Replace the engagement with a new one.

(16) Handling of residual and waste materials

  - Make sure to consult a waste treatment dealer for recommendations on the proper disposal of plastic valves. (Poisonous gas is generated when the valve is burned improperly.)

**3-Way Ball Valves Type 23
Electric Actuated Type T**

[Automatic Valve]



ASAHI AV VALVES

Distributor

Asahi Organic Chemicals Industry's homepage

<http://www.asahi-yukizai.co.jp/en/>

Information in this manual is subject to change without notice.

2011.6