

USER MANUAL



P19



Electrically powered wheelchair
Class A (EN 12184)



HEARTWAY

HEARTWAY MEDICAL PRODUCTS CO., LTD.

NO. 6, ROAD 25, TAICHUNG INDUSTRIAL PARK,
TAICHUNG. TAIWAN R.O.C.408
P.N.: 70030318

PUBLISHED: December 10th, 2013

P19

S/N : P19HTMK1390001



Year of Production: 2013

Manufacture Address:

**HEARTWAY – TAIWAN Heartway
Medical Products Co., Ltd.**

**Headquarter: NO.6 , ROAD 25 , TAICHUNG
INDUSTRIAL PARK, TAICHUNG, TAIWAN R.O.C.**

Maximum User Weight: 115 Kgs

In-Door Use Only

SAFETY INSTRUCTIONS

◆ General



Always use a seat belt, and keep your feet on the scooter all the time.



Never operate the scooter while you are under the influence of alcohol



Never use electronic radio transmitters such as walkie-talkies, or cellular phones.







Make sure that there are no obstacles behind you while reserving your scooter.



Do not make a sharp turn or a sudden stop while riding your scooter.



Do not rider your scooter in traffic.

 <p>Do not attempt to climb curbs greater than limitation show on Technical Specification</p>	 <p>Do not leave your hands and legs off the scooter when driving.</p>
 <p>Do not rider your scooter during snow in order to avoid accident on slippery road.</p>	 <p>Do not allow unsupervised children to play near this equipment while the batteries are charging.</p>

◆ Warning – Don't operate your power wheelchair without completely reading and understanding this user manual. Always use a seat belt, and keep feet on the footplate at all the time.

General

1. For safety reasons, make sure that your weight does not exceed the recommended weight limit of the wheelchair. Consult your dealer for the specified weight limits for your particular model.
2. Do not attempt to lift or move a power chair by any of its removable parts. Personal injury and damage to the power chair may result.
3. Do not stand on the footplate directly.
4. Never try to use your wheelchair beyond its limitations as described in this manual.
5. Do not operate your vehicle if it is not functioning properly.
6. Do not connect any electrical or mechanical device to the vehicle. Failure to obey this instruction may result in injury and will void the warranty.
7. Never use electronic radio transmitters such as, walkie-talkies, portable computers or cellular phones while using the vehicle without first turning the vehicle off
8. Don't operate scooter on public streets and roadways. Be aware that it may be difficult for traffic to see you when you are seated on the scooter. Obey all local pedestrian traffic rules. Wait until your path is clear of traffic, and then proceed with extreme cautions.
9. To prevent injury to yourself or others, always ensure that the power is switched off when getting on or off of the scooter.
10. Always check that the drive wheels are engaged (drive mode) before driving. Do not switch off the power when the power wheelchair is still moving forward. This will bring the chair to an extremely abrupt stop.
11. Do not use this product or any available optional equipment without first completely reading and

understanding these instructions. If you are unable to understand the warnings, cautions or instructions, contact a healthcare professional, the dealers or technical supports before attempting to use this equipment, otherwise, injury or damage may occur.

12. There are certain situations, including some medical conditions, where the scooter user will need to practice operating the scooter in the presence of a trained attendant. A trained attendant can be defined as a family member or care professional especially trained in assisting a scooter user in various daily living activities. Consult with your physician if you are taking any medication that may affect your ability to operate your scooter safely.
13. Do not attempt to lift or move a power scooter by any of its removable parts including the armrests, seats or shrouds. Personal injury and damage to the power chair may result.
14. Never try to use your scooter beyond its limitations as described in this manual.
15. Please do not sit on your scooter while it is in a moving vehicle.
16. Keep your hands away from the wheels (tires) while driving scooters. Be aware that loose fitting clothing can become caught in the drive tires.
17. Consult your physician if you are taking prescribed medication or if you have any certain physical limitations. Some medications and limitations may impair your ability to operate scooters in a safe manner.
18. Be aware when the drive mode is unlocked or locked.
19. Don't remove anti-tipper if there is any-tipper equipped with the scooter.
20. Contact with tools can cause electrical shock and do not connect an extension cord to the AC/DC converter or the battery charger.
21. Do not attempt to lift or move your scooter by any of its removal parts, such as the armrests, seats, or shroud.
22. When climbing an incline, don't drive at an angle up the face of the incline. Drive your scooter straight up the incline. This greatly reduces the possibility of a tip or a fall.
23. Don't climb a slope steeper than the scooter's limitation.
24. Don't attempt to have your scooter proceed backward down any step, curb or other obstacle. This may cause the scooter to fall or tip.
25. Always reduce your speed and maintain a stable center of gravity when cornering sharply. Don't corner sharply when driving scooters at higher speeds.
26. Operating in rain, snow, salt, mist conditions and on icy or slippery surfaces may have an adverse affect on the electrical system.
27. Never sit on your scooter when it is being used in connection with any type of lift or elevation product. Your scooter is not designed with such use in mind and any damage or injury incurred from such use is not the responsibility of Heartway.
28. Surfaces of the power wheelchair that can come into direct contact with the occupant's skin and/or assistant's skin during normal use and that are within occupant reach shall not exceed 41 °C. The motor surface can reach temperatures greater than 41°C after driving. Do not touch these parts when disassembling the scooter or wait until the motor is cooled down.
29. The programming of the controller shall only be carried out by personnel, which is authorized by his manufacturer. A wrong programming can result in safety hazards for the occupant!
30. If the power scooter is switched off while driving on the horizontal at maximum speed at 7 km/h, it will come to a stop with the maximum stopping distance of 1.2 m. Please consider this distance when driving.
31. Drive-wheel needs to be switched to engaged-mode while transporting the power scooter with a car or airplane.
25. Surface temperatures can increase when exposed to external sources of heat.

◆ Modifications

Heartway Medical Product has designed and engineered power wheelchair to provide maximum utility.

However, under no circumstances should you modify, add, remove, or disable any part or function of your power wheelchair. Do not modify your P19 in any way not authorized by Heartway Manufacturer.

Unauthorized modifications may result in personal injury and/or damage to your power chairs. Do not use accessories if they have not been tested or approved for Heartway products. Changing of controller parameter shall be only performed by authorized technicians due to the safety concern.

◆ **Inspections prior to using your power wheelchair**

1. If equipped with pneumatic tires, please check for proper tire inflations.
2. Please check all electrical connections and make sure they are tight and not corroded.
3. Please check all harness connections and make sure they are secured properly.
4. Please check the brakes.

◆ **Weight limitation.**

1. Please refer to the specifications table for weight capacity information. Power wheelchair is rated for a maximum weight capacity.
2. Stay within the specified weight capacity for your power wheelchair. Exceeding the weight capacity voids your warranty. Heartway will not be held responsible for injuries or property damage resulting from failure to observe weight limitations.
3. Don't carry passengers on power wheelchairs. Carrying passengers on power wheelchairs may affect the center of gravity, resulting in a tip or a fall.

◆ **Temperature**

1. Some of the parts of the power wheelchairs are susceptible to change in temperature. The controller can only operate in temperature that ranges between -25°C ~ 50°C.
2. At extreme low temperatures, the batteries may freeze, and your power wheelchairs may not be able to operate. In extreme high temperatures, it may operate at slower speeds due to a safety feature of the controller that prevents damage to the motors and other electrical components.

ELECTROMAGNETIC INTERFERENCE (EMI)

The rapid development of electronics, especially in the area of communications, has saturated our environment with electromagnetic (EM) radio waves that are emitted by television, radio and communication signals. These EM wave are invisible and their strength increases as one approach the source. All electrical conductors act as antennas to the EM signals and, to varying degrees, all power wheelchairs are susceptible to electromagnetic interference (EMI). The interference could result in abnormal, unintentional movement and/or erratic control of the vehicle. The United States Food and drug Administration (FDA) suggests that the following statement be incorporated to the user's manual for all power wheelchairs like the **P19**. Power wheelchairs may as susceptible to electromagnetic interference (EMI), which is interfering electromagnetic energy emitted from sources such as radio stations, TV stations, amateur radio (HAN) transmitter, two-way radios, cellular phones and alarm systems of shops. The interference (from radio wave sources) can cause the power wheelchairs to release its brakes, move by itself or move in unintended directions. It can also permanently damage the powered scooter's control system. The intensity of the EM energy can be measured in volts per meter (V/m). Each powered scooter can resist EMI up to a certain intensity. This is called "immunity level". The higher the immunity level the greater the protection. At this time, current technology is capable of providing at least 20 V/m of immunity level, which would provide useful protection against common sources of radiated EMI.

Following the warnings listed below should reduce the chance of unintended brake release or powered scooter movement that could result in serious injury:

1. Do not turn on hand-held personal communication devices such as citizens band (CB) radios and cellular phones while the powered scooter is turned on.
2. Be aware of nearby transmitters such as radio or TV stations and try to avoid coming close to them.
3. If unintended movement or brake release occurs, turn the powered scooter off as soon as it is safe.
4. Be aware that adding accessories or components, or modifying the powered scooter, may make it more susceptible to interference from radio wave sources (Note: It is difficult to evaluate the effect on the overall immunity of the powered scooter).
5. Report all incidents of unintended movement or brake release to the powered scooter manufacturer, and note whether there is a radio wave source nearby.

TURN OFF YOUR POWERED SCOOTER AS SOON AS POSSIBLE WHEN EXPERIENCING THE FOLLOWING:

- Unintentional scooter movements
- Unintended or uncontrollable direction.
- Unexpected brake release

The FDA has written to the manufacturers of power scooters asking them to test new products to be sure they provide a reasonable degree of immunity against EMI. The FDA requires that a powered wheelchair should have an immunity level at least 20 V/m, which provides a reasonable degree of protection against more common sources of EMI. The higher the immunity level the greater the protection. Your powered scooter has an immunity level of 20 V/m which should protect against common sources of EMI. Warning: The scooter itself can disturb the performance of the electromagnetic fields such as emitted by alarm systems of shops.

TECHNICAL SPECIFICATIONS

MODEL	P19
WEIGHT CAPACITY	115kgs(250 lbs)
SEAT: TYPE/SIZE	16" Fish-on
DRIVE WHEEL	200*50 (PU TIRE)
FRONT CASTER (WHEEL)	5*1-1/2" (PU TIRE)
MAX SPEED	6Km/hr
BATTERY SPECIFICATIONS	12V 12AHX2
BATTERY RANGE	15Km
CHARGER TYPE	5 AMP Charger --4C24050A
CONTROLLER TYPE	Dynamic 40 AMP Controller
TRAVELLING RANGE	Lithium 20 km/h. Lead-Acid 15 KM/H
MOTOR TYPE	150W*2
WEIGHT: W/ BATTERY	36.5 KG
WEIGHT: W/O BATTERY	28 KG
BATTERY BOX WEIGHT	8.5 KG
TURNING RADIUS	680mm
SUSPENSION	Front Suspension
LENGTH	850mm
WIDTH	520mm
HEIGHT	830mm
Folded Size	800*520*420
SEAT WIDTH	410mm
SEAT HEIGHT	350mm
SEAT DEPTH	330mm
BACK HEIGHT	360mm
GROUND CLEARANCE	40mm
KERB CLIMBING	40 mm
MAX SAFE SLOPE	6 Degree
WHEELBASE	640mm

ADJUSTMENT

It is very easy to assemble your P19 scooter. Please follow the procedure below.



P19 power scooter has aluminum alloy body and can be easily folded to fit in the car for transportation. It also has easy to use controls and adjustable tiller positioning.

- ⇒ Distinctive stylish lightweight scooter.
- ⇒ Easy to use controls.
- ⇒ Adjustable tiller positioning.
- ⇒ Easy to remove the battery pack.
- ⇒ Dismantles for transporting in a car.

See the Following Four Steps to Fold the Scooter

It is very easy to assemble your P19 Power Wheelchair. Please follow the procedure below. P19 power wheelchair has aluminum alloy body and can be easily folded to fit in the car for transportation. It also has easy to use controls and adjustable tiller positioning.

Steps to Un-Fold P19

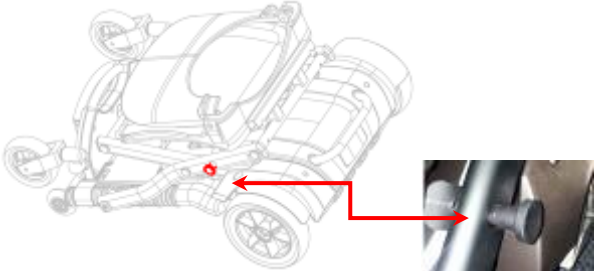
 <p>Pull the red lever bar to unfold the power wheelchair</p>	 <p>Fold the seat backrest</p>
 <p>Pull down the seat to fold the power wheelchair until the seat locks</p>	 <p>Make sure the cotter pin is the lock position properly before lifting the chair</p>

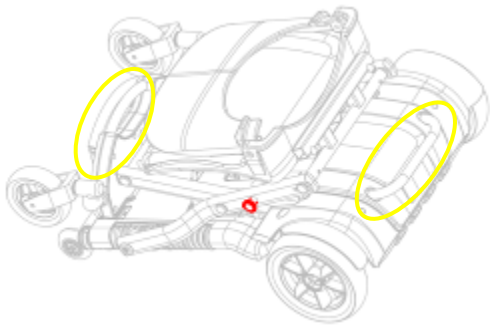

Please hold the rear handle bar and front handle bar to lift P19

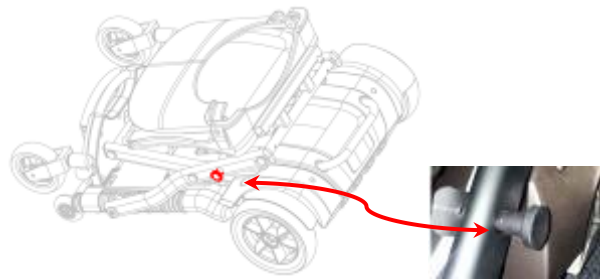

Pull the cotter pin on the side to begin the unfolding to unfold the power wheelchair

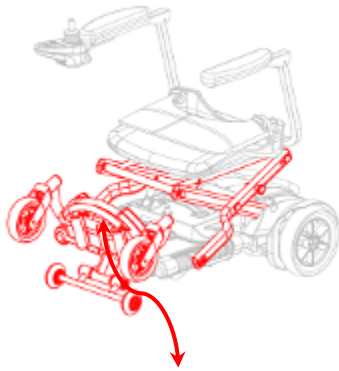

Pull down the front handle bar and pull up the backrest to unfold P19



Make sure to open the P19 until four wheels touch the ground and you hear a click indicating that the P19 is locked in the open position

WARNING

- ⇒ PLEASE TURN OFF THE POWER BEFORE FOLDING/UNFOLDING POWER WHEELCHAIR
- ⇒ Pinch Point—Be aware of fingers when folding and un-folding power wheelchair



- ⇒ Never open the battery box. If you have any question, please contact your local authorized dealer or technical supports for further support and assistance.

Storage

- Your power chair should be stored in a dry place, free from temperature extremes. When storing, disconnect the batteries from the power chair. If you fail to store the unit properly, the frame can rust and the electronics can be damaged.
- Batteries that are regularly and deeply discharged, infrequently charged, stored in extreme temperatures, or stored without a full charge may be permanently damaged, causing unreliable performance and limited service life. It is recommended that you charge the batteries periodically throughout periods of prolonged storage to ensure proper performance. You may wish to place several boards under the frame of your power chair to raise it off of the ground during periods of prolonged storage.

If you plan on not using your power wheelchair for an extended period of time, it is best to:

- ⇒ Fully charge its batteries prior to storage.
- ⇒ Disconnect the batteries from the scooter.
- ⇒ Store your power wheelchair in a warm, dry environment.
- ⇒ Avoid storing your power wheelchair where it will be exposed to temperature extremes.
- ⇒ Operating conditions (-25 °C ~ +50 °C) and Storage conditions (-40. °C ~+65°C)

Batteries that are regularly and deeply discharged, infrequently charged, stored in extreme temperatures, or stored without a full charge may be permanently damaged, causing unreliable performance and limited service life. It is recommended that you charge the power wheelchair batteries periodically throughout periods of prolonged storage to ensure proper performance.

OPERATION OF CONTROL PANEL

The power wheelchair is simple to operate. However, we recommend that you read carefully the following instructions to become familiarized with your new vehicle.

A Word of Caution:

Before you turn the power on, always be aware of the environment that surrounds you to select your desired speed. For indoor environments we recommend that you select the slowest speed setting. For outdoor operation of this vehicle we recommend that you select a speed that is comfortable for you to control it safely. The following steps are required to operate your vehicle safely with the controller-can use for P19



(Fig 19)

As a visual reminder, a speed symbol (shown left) is positioned just below the speed dial to indicate the low and high positions of the speed dial.



Low High

Controller ON/OFF Switch

Press the ON/OFF button (I/O) switch located in front of the joystick to activate your power wheelchair. The battery condition meter will light up to indicate the current charge of your battery. Pressing the ON/OFF button again will deactivate the controller.

Speed control

The speed dial allows the users to limit the maximum speed of the wheelchair to suit their preference and environment. The dial offers 10 discrete steps between the lowest speed (dial set to the left) and the highest speed (dial set to the right)

Joystick

The joystick controls the direction and speed of your vehicle, pointing the joystick away from the neutral position (center) will move the vehicle in the direction where the joystick is pointing. The farther away (forward/backward) the joystick is from the neutral position, the faster the vehicle will go. The farther away to the right/ left the joystick is pointing, the sharper the turn of the vehicle will be. To operate the vehicle by gently pushing the joystick in the direction you want to go. Returning

the joystick to its neutral position (center) will reduce the speed and stop the vehicle by automatically applying the electromagnetic brakes.

Notes:

After pressing the controller ON/OFF switch, allows two seconds to elapse before engaging the joystick. This is a safety feature to prevent sudden start. Gentle operation of the joystick will result in smoother transitions in speed and direction, while sharp operation of the joystick will result in drastic transitions in direction and velocity. When the wheelchair is in operation, the surface of the charger will become slightly hot. In case of emergency, let go of the joystick and the chair will come to a stop.

Note: When the batteries begin to approach a discharged state, the first red LED will begin to flash slowly, reminding you that the batteries need to be charged immediately.

Electromagnetic Brakes:

Your power wheelchair comes with an Electromagnetic Brakes, i.e. an automatic magnetic disc safety brake which is also known as Fail-Safe brake. The Electro-magnetic Brakes are automatic and work when the power wheelchairs is ON but in a steady state (i.e. Joystick is released to the neutral position), even when the chair is on a slope. The Electromagnetic Brakes will also be set when-ever the power wheelchair is OFF, but the motor levers are in the engaged (vertical) position.

Thermal Protection:

Your power wheelchair controller is equipped with a safety system called thermal rollback. A built-in circuit monitors the temperature of the controller and motors, the controller reduces the motor voltage and speed of the power wheelchair. The reduction of the speed allows the electrical components to cool down. Although your power wheelchair will resume its normal speed when the temperature returns to a safe level, we recommend that you turn the power off and wait for 5 minutes before restarting to allow the components to cool down if you find that you have lost speed suddenly.

Free-Wheeling:

The motors are designed to engage the electromagnetic brakes when the vehicle is not in use or when the power is OFF.

Warning !

- ⇒ Never free-wheel your power wheelchair on a slope.
- ⇒ Never free-wheel the motors while operating your vehicle.
- ⇒ Always remember to engage the motors before turning the power ON.
- ⇒ PLEASE TURN OFF THE POWER BEFORE FOLDING/UNFOLDING POWER WHEELCHAIR

Electromagnetic Brakes:

Your power wheelchair comes with Electromagnetic Brakes., i.e. an automatic magnetic disc safety brake which is also known as Fail-Safe brake. The electro-magnetic Brakes are automatic and work when the power wheelchair is ON but in a steady state (i.e. Wigwag is released to the neutral position), even when the power wheelchair is on a slope. The Electromagnetic Brakes will also be set whenever the power wheelchair is OFF, but the motor levers are in the engaged (vertical) position.

Parking brake:

There is an automatic parking brake function included in the electromagnetic brake. The power wheelchair will stop when the motor is engaged and the power switch is off or when the power switch is on and the wigwag is in the neutral position. If the power wheelchair is in the free wheel mode (motor is disengaged), you can use the manual parking brake function by moving the engaging/disengaging lever back into the engaged position by an attendant.

Thermal Protection:

Your power wheelchair controller is equipped with a safety system called thermal rollback. A built-in circuit monitors the temperature of the controller and motor. In case of excessive heat of the controller and motor, the controller will cut-off the power to allow the electrical components to cool down. Although your power wheelchair will resume its normal operation when the temperature returns to a safe level, we recommend to wait for 5 minutes before restarting to allow the components to cool down.

Remove the battery box from the power wheelchair



Pull the bar to remove the battery box from the power wheelchair

Put the battery box back to the power wheelchair

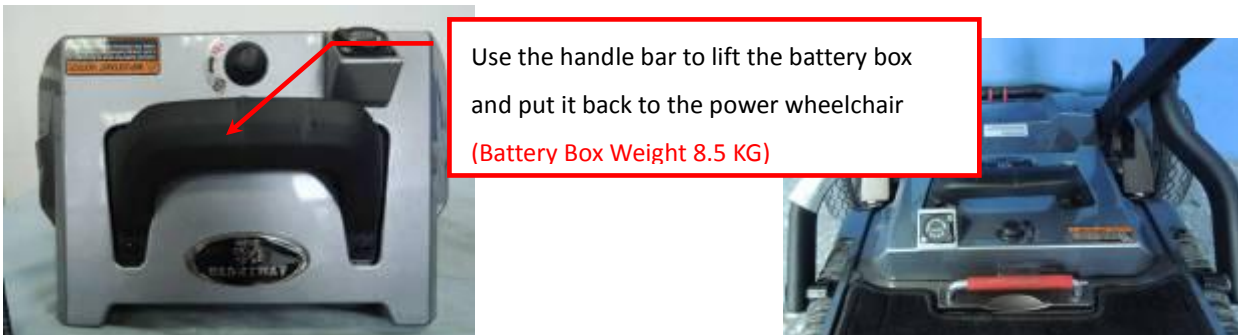

Use the handle bar to lift the battery box and put it back to the power wheelchair
(Battery Box Weight 8.5 KG)

Make sure the battery connectors are connected properly after you install the batteries into the power wheelchair

BATTERY & CHARGING INTRUCTION

Lead-Acid Battery

We recommend that you use deep-cycle batteries that are sealed and maintenance free for your power wheelchair. Both sealed lead-acid (SLA) and gel cell are deep-cycle batteries and are similar in performance. Deep-cycle batteries are specifically designed to provide power, drain down, and then accept a relatively quick recharge. Lead-acid batteries should be charged as often as possible.

Specification of the battery that we recommend for P19 is

Type:	Deep –cycle sealed lead-acid or gel cell
Size:	12AH
Voltage:	12V each
Amp Hours:	12 amp hours

If the power wheelchair is not in use, we recommend that the batteries are charged periodically.

Lithium Battery (11.5A)

Specifications

Nominal Voltage	24 V
Nominal Capacity	11,500 mAh
Charging Current	2,000 mA
Charging Time	5-6 hrs
Ambient	Charge 0°C to +45°C (+32°F to 113°F)
	Discharge -20°C to +65°C (-4°F to 140°F)
Temperature Storage	≤ 30°C (86°F)
Weight	Max. 2 kg
Length*Width*Height	191*78*114 mm

BATTERY CHARGER

The battery charger takes the standard wall outlet voltage (alternating current) and converts it into DC voltage (direct current). The batteries use direct current to run your power wheelchair. When the batteries are fully charged, the amperage from the charger is almost at zero. This is how the charger maintains a charge but does not overcharge the battery.

Note 1: The batteries cannot be charged if they were discharged to nearly zero voltage.

Note 2: The powered wheelchair meet the requirement of ISO 7176-14:2008 and ISO 7176-21:2003.

Note 3: Only use the battery charger type 4C24050A which was provided by the supplier. The use of any different type of charger can be hazardous and need the approval of the manufacturer.

Charger Specification

Item	BATTERY CHARGER (SWITCHING MODE)
Model	4C24050A
Output Current(DC)	5A
Charging Voltage(DC)	28.8V
Floating Voltage(DC)	27.6V
Input Current (AC)	4/2 A
Input Voltage(AC)	115 Vac Or 230 Vac 50/60 Hz (Manual Select)
Efficiency	AC-DC 80% min
Operating Temperature	0°C ~ 40°C
Performance	Switching Mode
Charging Method	Constant current two stage constant voltage
Battery Application	24V Lead Acid Rechargeable Battery (20Ahr ~ 60Ahr)
Output Detection	<ol style="list-style-type: none"> 1. Short Circuit Protection 2. Output Voltage/ Current Limit 3. Reverse Power Protection 4. Overheat Detection
Operating Temperature	0~ 40 Degree (Celsius)
Measure	L 190mm×W 100mm×H 55mm
Weight	965g
Color	Black

CHARGING INSTRUCTIONS

To recharge the batteries, follow the steps below:

- ⇒ Place your power wheelchair close to a standard electrical wall outlet.
- ⇒ Remove your key to turn the power OFF
- ⇒ Slide the charger port door open.
- ⇒ Plug the XLR connector of the charger to the charger port.
- ⇒ Plug the other end of power cord into a standard wall outlet.
- ⇒ When charging is completed, battery capacity indicator is shown.
- ⇒ Disconnect the charger power cord from the wall outlet when the batteries are fully charged.

Recharge battery only when the key is in off position. When indicator is in low status, this confirms the battery needs recharging.

Note:

- ⇒ Always charge your batteries in well ventilated areas.
- ⇒ The charger is intended for indoor use only. Protect from moisture.
- ⇒ For maximum performance, it is recommended that you replace both batteries at the same time if the batteries are weak.
- ⇒ If the vehicle will not be used for a long period of time, arrange to have the batteries recharged at least once every month to avoid deterioration of the batteries.

According to the battery type and condition of the batteries, they usually can be fully charged in 4-10 hours. This will be indicated when the status light in the battery charger side panel turns green. Charging the battery longer than necessary will not harm the battery. We recommend that you charge the batteries for 8 to 10 hours after daily use.

OPERATING INSTRUCTION

1. Make sure the battery charger output voltage is the same as the connecting battery.
2. Plug in the power cord. LED indicates green flash when AC power on.
3. Connect the battery charger to the battery.
4. Start charging;

4. LED INDICATION

- (1)Green Flash : Power on
 - (2)Orange : Charging
 - (3)Orange Flash : Pre charge
 - (4)Green & Orange Flash : Charged 80% ◦
 - (5)Green : Full charged(Floating charge) ◦
 - (6)Red: Error / Abnormal temperature
- Red indication keeps flashing: $1V < \text{Battery voltage} < 9V$
 - Red indication keeps flashing X 2: a) Wrong connection b) Short circuit c) VBAT <16V
 - Red indication keeps flashing X 3: a) VBAT > 28.8V (can't charge the battery) b) Battery and Jimmy are defective
 - Red indication keeps flashing X4: a) Charging system defective b) Battery defective partially
 - Red indication keeps flashing X5: a) Charging hours exceeds 24 hours
 - Red indication keeps flashing X6: a) Battery voltage < 16V (12V Battery)
 - Red indication keeps flashing X7: a) Abnormal temperature occurs during battery charging

5. TROUBLE SHOOTING

- (1) If green indicator is off :
 - Check AC input. If it works functionally, the battery charger may be defective.
- (2) If green indicator keeps flashing and cannot turn to charging indication :
 - Check if the battery connector is connected successfully.
 - Check if there is any short circuit on the output connection.
 - The battery charger may be defective if the battery connection works functionally.
- (3) If red indicator keeps flashing :
 - Check if the battery connection is reversed.
 - Check if there is any short circuit on the output connection.
 - Check if the environment temperature is too low (0°C)
 - The battery charger may be defective if the red indicator still keeps flashing.
- (4) Charging indicator (orange) cannot turn to green :
 - The battery might be defective, please stop charging and have the battery be repaired.

(5) If the charging indicator (orange) turns to green (fully charged) immediately :

- The battery may be in well-charged condition.
- The battery may be defective if the battery is not fully charged.

6. CAUTION

- (1) Before using the battery charger, read all instructions and cautionary markings.
- (2) Use the battery charger in a well-ventilated area
- (3) To avoid the risk of injury, charge only lead-acid or gel cell type rechargeable batteries.
- (4) Please turn off the power after charging

Note: Only use the battery charger which was provided by the power wheelchair supplier. The use of any different type of charger can be hazardous and need the approval of the manufacturer.



WARNING !

- ✧ Always charge your batteries in well ventilated areas.
- ✧ The charger is intended for indoor use only. Please protect it from the moisture.
- ✧ For maximum performance, it is recommended that you replace both batteries at the same time if the batteries are weak.
- ✧ If the power wheelchair will not be used for a long period of time, arrange to have the batteries recharge at least once every month to avoid deterioration of the batteries.
- ✧ Can we use a different charger? Please understand that chargers are selected specifically for particular applications and matched to the type and size of specific batteries. In order to charge your power wheelchair safely and efficiently, we recommend use of the charger supplied as original equipment with your Heartway product only. Any charging method resulting in batteries being charged individually is prohibited.

Note:

- Always charge your batteries in well ventilated areas.
- The charger is intended for indoor use only. Protect from moisture.
- For maximum performance , it is recommended that you replace both batteries at the same time if the batteries are weak.
- If the chair will not be used for a long period of time, arrange to have the batteries fully charge for at least once every month.

According to the battery type and condition of the batteries, batteries usually can be fully charged in 4-10 hours. This will be indicated when the status light in the battery charger side panel turns green. Charging the battery longer than necessary will not harm the battery. We recommended that you charge the batteries for 8 to 10 hours after daily use. Do not charge the batteries for more than 24 hours. Note: There is a battery circuit diagram labeled on the frame. Please refer this diagram before you assemble the battery.

BATTERY INDICATOR

A battery indicator is to provide information about the travelling range remaining.

Indicator	Travelling Range Remaining
Full	15 km Traveling Range Remaining
Green Area	7~15 km Travelling Range Remaining
Yellow Area	4~7 km Travelling Range Remaining
Red Area	1~4 km Travelling Range Remaining
End	0 Kilometer

MAINTENANCE INSTRUCTION

- Read through the charger operating instruction before using it.
- Make sure you charge the battery every time after you use the power chair or scooter.
- Charge the battery at least 24 hours a week if the power chair or scooter has not been used. (This is to make sure that the electrolyte is always at the top level)
- If the battery cannot be charged (Orange light cannot turn to Green) or if the Orange light turns to Green immediately, please check it with the technicians. The battery may be defective.
- The voltage difference between the two batteries on a power unit cannot be more than 0.5 V; the battery case should be inspected for cleanliness and evidence of damage.
- If the charger indicates red light, please kindly check if the charger is defected or if the cable wiring connection is poor.
- Please keep the battery terminals clean otherwise the charging condition will be poor.

MAINTENANCE & REPAIR

Your power wheelchair is designed for minimal maintenance. However, like any motorized vehicle it requires routine maintenance. To keep your P19 for years of trouble-free operation, we recommend you follow the following maintenance checks as scheduled.

The motor surface can reach temperatures greater than 41°C after driving. Do not touch these parts when disassembling the power wheelchair or wait until the motor is cooled down

DAILY CHECKS

1. Visual check on the conditions of tires.
2. Inspect the battery condition meter on the controller to determine if batteries need to be charged.

MONTHLY CHECKS

1. Visually inspect the controller harnesses. Make sure that they are not frayed, cut or have any exposed wires.

SEMI-ANNUAL CHECKS

1. Check the motor brushes. We recommended that your authorized dealer inspect the brushes every six months or sooner if your power wheelchair is not operating smoothly. If inspection determines excessive wear on the brushes, they must be replaced or motor damage will result.

Disposal of Your Power Chair

Your power chair must be disposed of according to applicable local and national statutory regulations. Contact your local waste disposal agency or authorized dealer for information on proper disposal of power chair packaging, metal frame components, plastic components, electronics, batteries, neoprene, silicone, and polyurethane materials.

CHECKS:

- Make sure to keep the controller clean while protecting it from rain or water. Never hose off your power wheelchair or place it in direct contact with water.
- Keep wheels free from lint, hair, sand and carpet fibers.
- All upholstery can be washed with warm water and mild soap. Occasionally check the seat and back for sagging, cuts and tears. Replace if necessary. Do not store your power wheelchair in damp or humid conditions as this will lead to mildew and rapid deterioration of the upholstery parts.
- All moving mechanism will benefit from simple lubrication and inspection. Lubricate using petroleum jelly or light oil. Do not use too much oil, otherwise small drips could stain and damage carpets and furnishings etc. Always perform a general inspection of the tightness of all nuts and bolts.

TROUBLESHOOTING & FAULT REPAIR

Dynamic 40 AMP CONTROLLER: Your power wheelchair is fitted with DYNAMIC controller, which continuously monitors the operating conditions of your power wheelchair. If it detects a problem it will indicate with error message by flashing light on the power ON/ OFF light. You must count the number of the flash, and see the list to check what kind of error has happened according to the number)

If, when powered up, there is an error with the system, then the status indicator will flash red. The number of flashes will indicate the type of error. These are described in the table below.

Flash code	Error description
1	Remote / joystick error
2	Network or configuration error
3	Left motor error
4	Right motor error
5	Left park brake error
6	Right park brake error
7	Module error (other than Remote)

Note:

If you experience any technical problems, it is recommended that you check with your local dealer before attempting to troubleshoot on your own.

The following symptoms could indicate a serious problem with your power wheelchair. Contact your local dealer if any of the following arises:

1. Motor noise
2. Frayed harnesses
3. Cracked or broken connectors
4. Uneven wear on any of tires
5. Jerky motion
6. Pulling to one side
7. Bent or broken wheel assemblies
8. Does not power up
9. Powers up, but does not move

CIRCUIT DIAGRAM

HW-05-02A

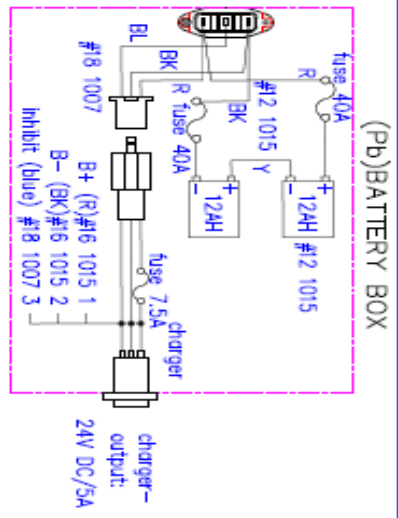
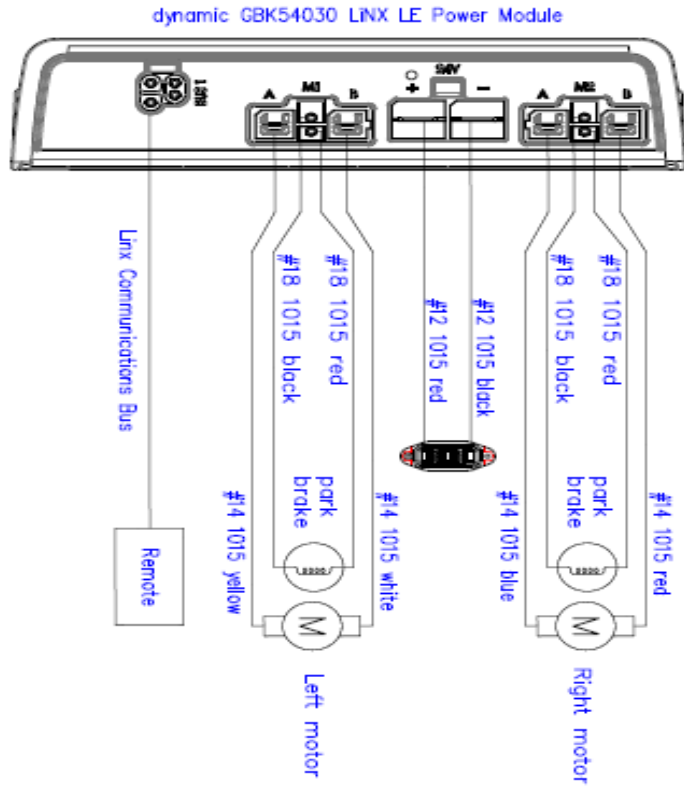

- COLOR:
- BK: black
 - BR: brown
 - BU: blue
 - C: cyan
 - DG: dark green
 - G: gray
 - GR: green
 - LG: light green
 - LO: light orange
 - O: orange
 - P: pink
 - R: red
 - V: violet
 - W: white
 - Y: yellow

比例	1:1	確認
單位	mm	指定
數量		李漢林
材質		日期
計算		2003/11/26

品號	品名	P1料號	M1料號	單位	公差	機種	料號	備註
		S1材料加工		1-20	±0.2	名稱	WIRE DIAGRAM (Linx LE)	
		無	電鍍	21-45	±0.4	圖號	P190E902	
		CP	烤漆	66-80	±0.7			
			其他	90-99	±1.0			

變更內容	日期	確認	核准	修正	處理	製作	其他

台灣慈順工業股份有限公司 HEARTWAY MEDICAL PRODUCTS CO., LTD.	

WARRANTY DECLARATION

Quality/ Warranty Declaration

Products are to be fit for purpose and of excellent quality and performance. For valid warranty claims Heartway will, at their discretion, replace/ repair/ refund items mutually agreed to be defective.

Heartway's Warranty as Following:

- Frame: Two-year limited warranty
- Controllers: One-and-a-half-year limited warranty
- Electronic Components and Charger: One-year limited warranty
- Warranty Exclusion. The following items are not covered by warranty.
 - ✧ Motor brushes ✧ Wheel Tires ✧ Arm Pads
 - ✧ Seat Cushion ✧ Fuses / Bulbs ✧ Tiller Cover
 - ✧ Rear Shroud ✧ Front Shroud ✧ Batteries and Consumable parts

Any damage or defect of any nature occurring from the misuse, abuse of the product, improper operation or improper storage is not to be covered. The warranty is to start from the date of arrival of our products.

Normally, the average lifespan of a power wheelchair will last 5-year long. Heartway will be able to provide the spare-part support for five-year long after power wheelchairs purchased.

Note: If you encounter a damaged or cracked battery; please enclose it in a plastic bag and call the local authorized dealers immediately for instructions on disposal and recycling.



HEARTWAY MEDICAL PRODUCTS CO., LTD.

NO. 6, ROAD 25, TAICHUNG INDUSTRIAL PARK,
TAICHUNG. TAIWAN R.O.C.408